



Product Specification

AU OPTRONICS CORPORATION

() Preliminary Specifications

(✓) Final Specifications

Module	15.6" (15.55) FHD 16:9 Color TFT-LCD with LED Backlight design
Model Name	B156HW03 V0 (H/W:0A)
Note ()	LED Backlight with driving circuit design

Customer	Date
_____	_____
Checked & Approved by	Date
_____	_____
Note: This Specification is subject to change without notice.	

Approved by	Date
<u>Vicki Chai</u>	<u>03/29/2011</u>
Prepared by	Date
<u>Aries Hsu</u>	<u>03/29/2011</u>
NBBU Marketing Division / AU Optronics corporation	



Product Specification

AU OPTRONICS CORPORATION

Contents

1. Handling Precautions	4
2. General Description	5
2.1 General Specification	5
2.2 Optical Characteristics	6
3. Functional Block Diagram	11
4. Absolute Maximum Ratings	12
4.1 Absolute Ratings of TFT LCD Module	12
4.2 Absolute Ratings of Environment	12
5. Electrical characteristics	13
5.1 TFT LCD Module	13
5.1.1 Power Specification	13
5.1.2 Signal Electrical Characteristics	14
5.2 Backlight Unit	15
5.2.1 LED characteristics	15
6. Signal Characteristic	16
6.1 Pixel Format Image	16
6.2 The input data format	17
6.3 Integration Interface and Pin Assignment	18
6.3.1 Connector Description	18
6.3.2 Pin Assignment	18
6.4 Interface Timing	21
6.4.1 Timing Characteristics	21
6.4.2 Timing diagram	21
7. Vibration and Shock Test	23
7.1 Vibration Test	23
7.2 Shock Test Spec:	23
7.3. Reliability	23
8. Mechanical Characteristics	24
8.1 LCM Outline Dimension	24
8.1.1 Standard Front View	24
8.1.2 Standard Rear View	25
9. Shipping and Package	26
9.1 Shipping Label Format	26
9.2. Carton package	27
9.3 Shipping package of palletizing sequence	27
10. Appendix: EDID description	28



Product Specification

AU OPTRONICS CORPORATION

Record of Revision

Version and Date	Page	Old description	New Description	Remark
0.1 2010/10/26	All	Preliminary Edition for Customer		
0.2 2010/12/22	18,21 ,22,2 8-31	Preliminary Edition for Customer	Preliminary Edition for Customer	
0.2 2011/03/29	All		Final specifaction	



Product Specification

AU OPTRONICS CORPORATION

1. Handling Precautions

- 1) Since front polarizer is easily damaged, pay attention not to scratch it.
- 2) Be sure to turn off power supply when inserting or disconnecting from input connector.
- 3) Wipe off water drop immediately. Long contact with water may cause discoloration or spots.
- 4) When the panel surface is soiled, wipe it with absorbent cotton or other soft cloth.
- 5) Since the panel is made of glass, it may break or crack if dropped or bumped on hard surface.
- 6) Since CMOS LSI is used in this module, take care of static electricity and insure human earth when handling.
- 7) Do not open nor modify the Module Assembly.
- 8) Do not press the reflector sheet at the back of the module to any directions.
- 9) At the insertion or removal of the Signal Interface Connector, be sure not to rotate nor tilt the Interface Connector of the TFT Module.
- 11) After installation of the TFT Module into an enclosure (Notebook PC Bezel, for example), do not twist nor bend the TFT Module even momentary. At designing the enclosure, it should be taken into consideration that no bending/twisting forces are applied to the TFT Module from outside. Otherwise the TFT Module may be damaged.
- 12) Small amount of materials having no flammability grade is used in the LCD module. The LCD module should be supplied by power complied with requirements of Limited Power Source (IEC60950 or UL1950), or be applied exemption.
- 13) Disconnecting power supply before handling LCD modules, it can prevent electric shock, DO NOT TOUCH the electrode parts, cables, connectors and LED circuit part of TFT module that a LED light bar build in as a light source of back light unit. It can prevent electrostatic breakdown.



Product Specification

AU OPTRONICS CORPORATION

2. General Description

B156HW03 V0 is a Color Active Matrix Liquid Crystal Display composed of a TFT LCD panel, a driver circuit, and LED backlight system. The screen format is intended to support the 16:9 FHD (1920(H) x 1080(V)) screen and 262k colors (RGB 6-bits data driver) with LED backlight driving circuit. All input signals are LVDS interface compatible.

B156HW03 V0 is designed for a display unit of notebook style personal computer and industrial machine.

2.1 General Specification

The following items are characteristics summary on the table at 25 °C condition:

Items	Unit	Specifications			
Screen Diagonal	[mm]	15.6" (15.55)			
Active Area	[mm]	344.16 x 193.59			
Pixels H x V		1920 x 3(RGB) x 1080			
Pixel Pitch	[mm]	0.17925 x 0.17925			
Pixel Format		R.G.B. Vertical Stripe			
Display Mode		Normally White			
White Luminance (I_{LED}=6.5mA) (Note: I_{LED} is LED current)	[cd/m ²]	300 Typ. (5 points average) 255 Min. (5 points average)			
Luminance Uniformity		1.25 Max. (5 points)			
Contrast Ratio		500 :1 Typ			
Response Time	[ms]	8 Typ / 16 Max.			
Nominal Input Voltage VDD	[Volt]	+3.3 Typ.			
Power Consumption	[Watt]	8.0 Max. (Include Logic and BLU Power)			
Weight	[Grams]	440 Max.			
Physical Size Without inverter, bracket.	[mm]		Min.	Typ.	Max.
		Length	359	359.5	360
		Width	223.3	223.8	224.3
		Thickness			4.1
Electrical Interface		2 channel LVDS			
Glass Thickness	[mm]	0.5			
Surface Treatment		Glare			
Support Color		262K colors (RGB 6-bit)			
Temperature Range Operating Storage (Non-Operating)	[°C] [°C]	0 to +50 -20 to +60			
RoHS Compliance		RoHS Compliance			



Product Specification

AU OPTRONICS CORPORATION

2.2 Optical Characteristics

The optical characteristics are measured under stable conditions at 25°C (Room Temperature) :

Item	Symbol	Conditions	Min.	Typ.	Max.	Unit	Note
White Luminance ILED=20mA		5 points average	255	300	-	cd/m ²	1, 4, 5
Viewing Angle	θ_R θ_L	Horizontal (Right) CR = 10 (Left)	60 60	70 70	- -	degree	4, 9
	ψ_H ψ_L	Vertical (Upper) CR = 10 (Lower)	45 50	60 60	- -		
Luminance Uniformity	δ_{5P}	5 Points	-	-	1.25		1, 3, 4
Luminance Uniformity	δ_{13P}	13 Points	-	-	1.50		2, 3, 4
Contrast Ratio	CR		400	500	-		4, 6
Cross talk	%				4		4, 7
Response Time	T_{RT}	Rising + Falling	-	8	14	msec	4, 8
Color Chromaticity Coordinates	Red	Rx	0.590	0.620	0.650	CIE 1931	4
		Ry	0.319	0.349	0.379		
	Green	Gx	0.294	0.324	0.354		
		Gy	0.576	0.606	0.636		
	Blue	Bx	0.122	0.152	0.182		
		By	0.088	0.118	0.148		
	White	Wx	0.283	0.313	0.343		
		Wy	0.299	0.329	0.359		
NTSC	%		--	60			



Product Specification

AU OPTRONICS CORPORATION

Note 1: 5 points position (Ref: Active area)

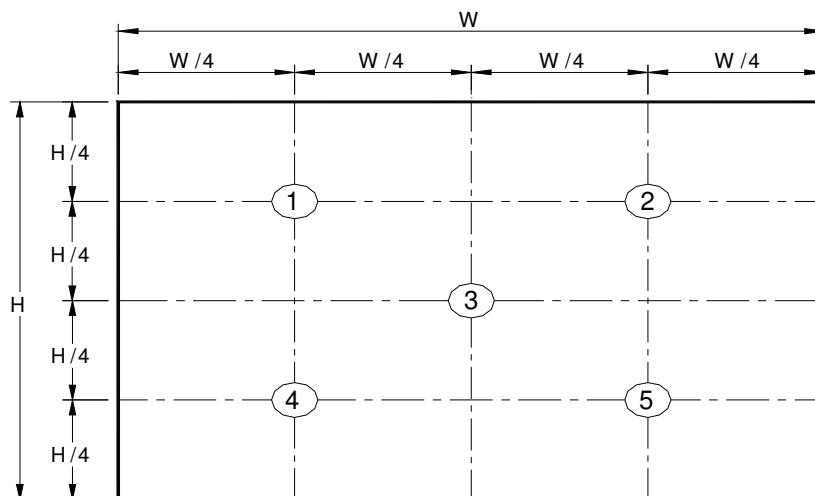

Note 2: 13 points position (Ref: Active area)

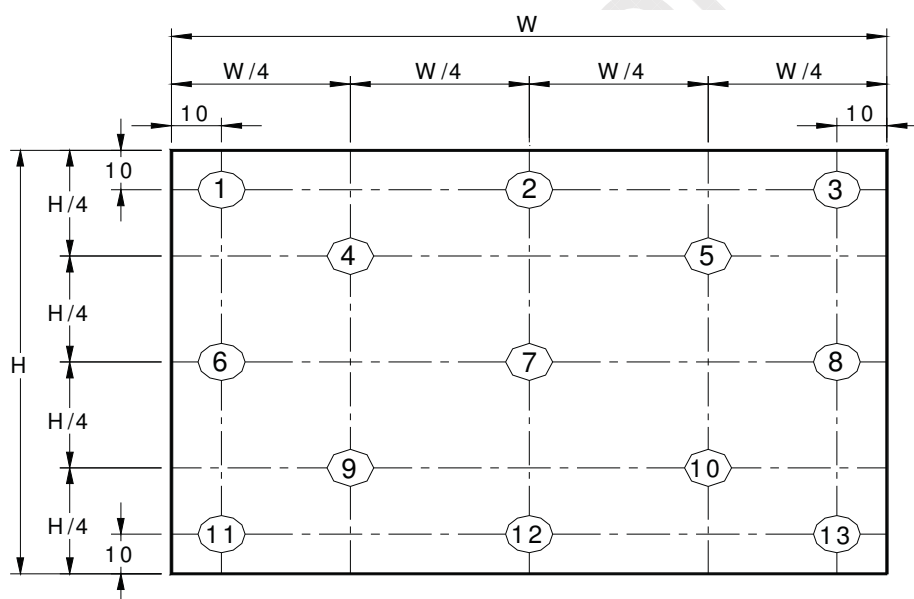

Note 3: The luminance uniformity of 5 or 13 points is defined by dividing the maximum luminance values by the minimum test point luminance.

$$\delta_{W5} = \frac{\text{Maximum Brightness of five points}}{\text{Minimum Brightness of five points}}$$

$$\delta_{W13} = \frac{\text{Maximum Brightness of thirteen points}}{\text{Minimum Brightness of thirteen points}}$$

Note 4: Measurement method

The LCD module should be stabilized at given temperature for 30 minutes to avoid abrupt temperature change during measuring. In order to stabilize the luminance, the measurement should be executed after



Product Specification

AU OPTRONICS CORPORATION

lighting Backlight for 30 minutes in a stable, windless and dark room, and it should be measured in the center of screen.

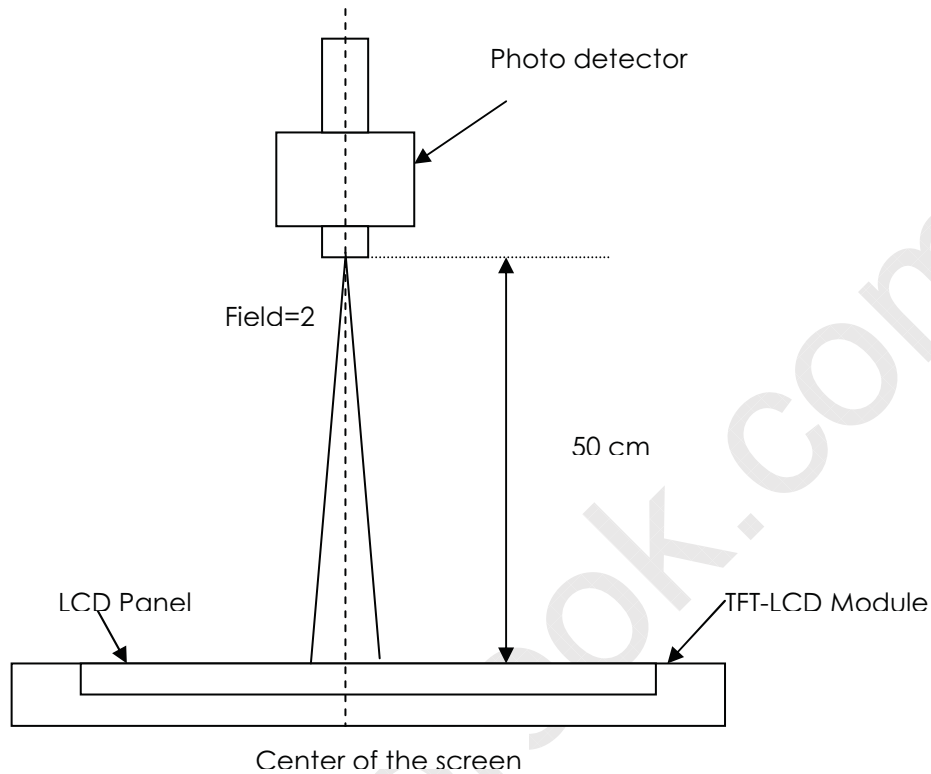

Note 5 : Definition of Average Luminance of White (Y_L):

Measure the luminance of gray level 63 at 5 points , $Y_L = [L (1)+ L (2)+ L (3)+ L (4)+ L (5)] / 5$

$L (x)$ is corresponding to the luminance of the point X at Figure in Note (1).

Note 6 : Definition of contrast ratio:

Contrast ratio is calculated with the following formula.

$$\text{Contrast ratio (CR)} = \frac{\text{Brightness on the "White" state}}{\text{Brightness on the "Black" state}}$$

Note 7 : Definition of Cross Talk (CT)

$$CT = | Y_B - Y_A | / Y_A \times 100 (\%)$$

Where

Y_A = Luminance of measured location without gray level 0 pattern (cd/m²)

Y_B = Luminance of measured location with gray level 0 pattern (cd/m²)



Product Specification

AU OPTRONICS CORPORATION

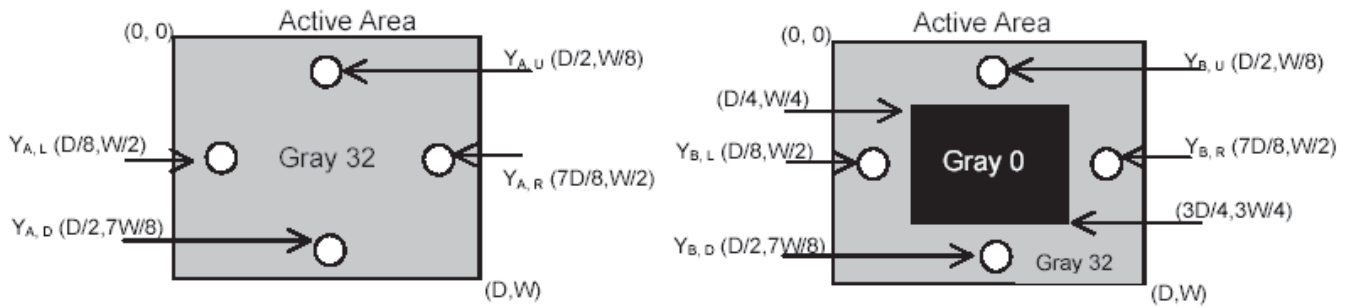

Note 8 : Definition of response time:

The output signals of BM-7 or equivalent are measured when the input signals are changed from "Black" to "White" (falling time) and from "White" to "Black" (rising time), respectively. The response time interval between the 10% and 90% of amplitudes. Refer to figure as below.

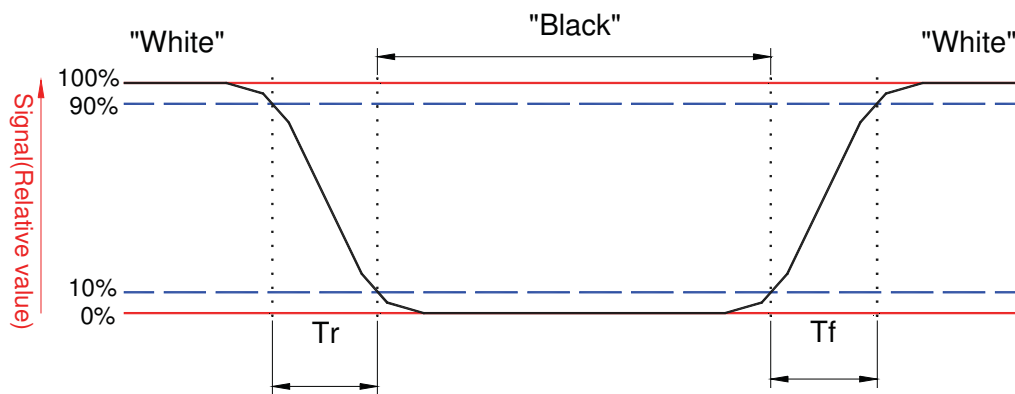



Product Specification

AU OPTRONICS CORPORATION

Note 9 : Definition of view angle

Viewing angle is the measurement of contrast ratio ≥ 10 , at the screen center, over a 180° horizontal and 180° vertical range (off-normal viewing angles). The 180° viewing angle range is broken down as follows; 90° (θ) horizontal left and right and 90° (Φ) vertical, high (up) and low (down). The measurement direction is typically perpendicular to the display surface with the screen rotated about its center to develop the desired measurement viewing angle.

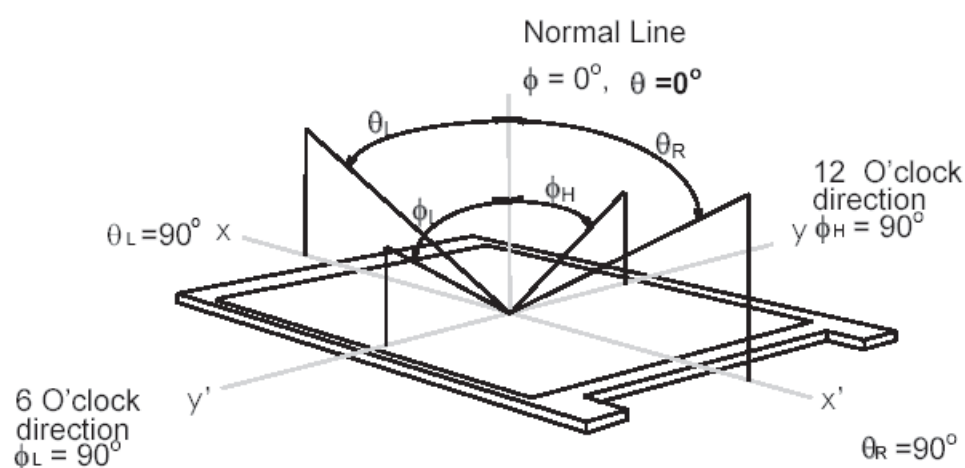



Product Specification

AU OPTRONICS CORPORATION

3. Functional Block Diagram

The following diagram shows the functional block of the 15.6 inches wide Color TFT/LCD 40 Pin.

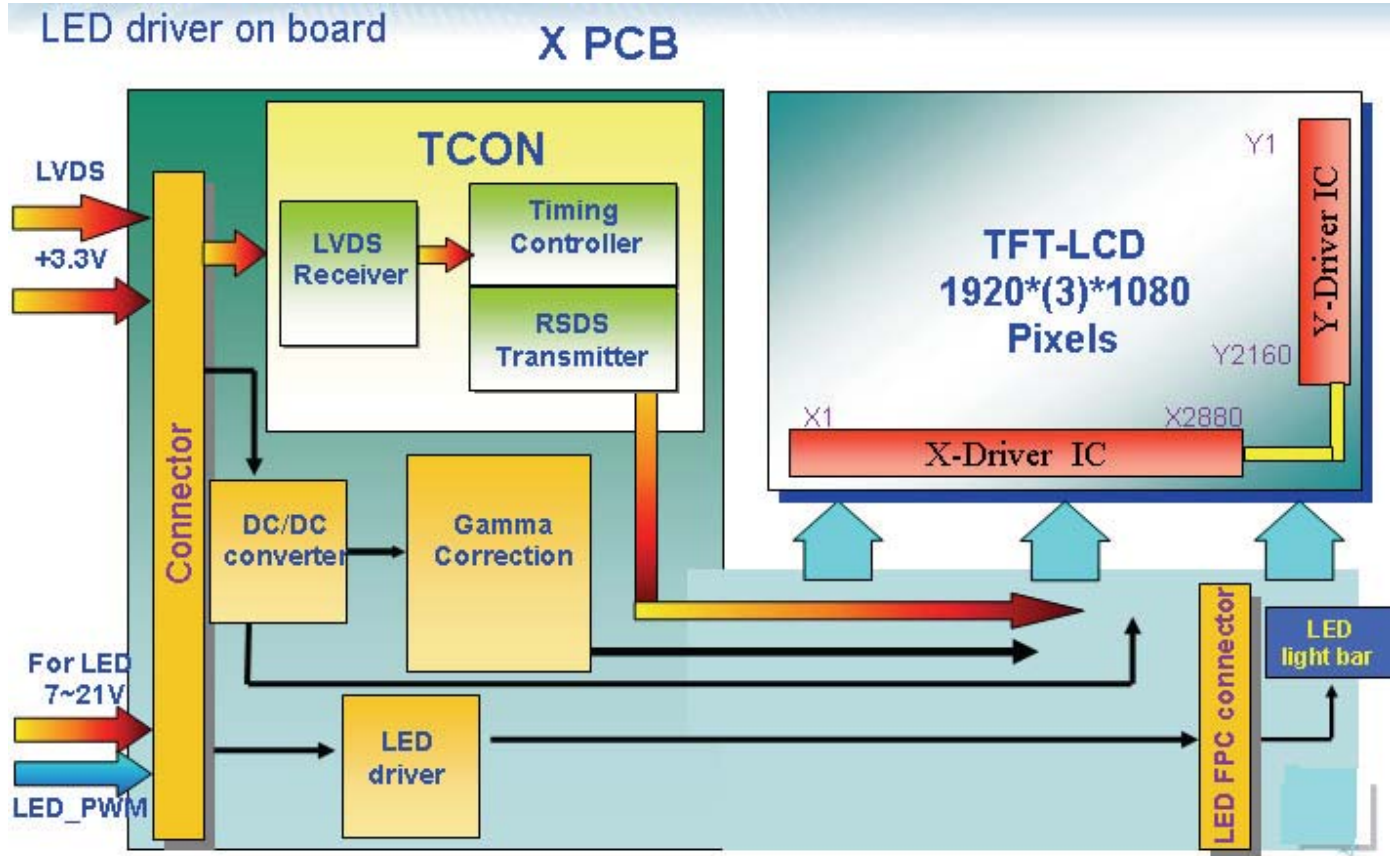



Product Specification

AU OPTRONICS CORPORATION

4. Absolute Maximum Ratings

An absolute maximum rating of the module is as following:

4.1 Absolute Ratings of TFT LCD Module

Item	Symbol	Min	Max	Unit	Conditions
Logic/LCD Drive	Vin	-0.3	+4.0	[Volt]	Note 1,2

4.2 Absolute Ratings of Environment

Item	Symbol	Min	Max	Unit	Conditions
Operating	TOP	0	+50	[°C]	Note 4
Operation Humidity	HOP	8	95	[%RH]	Note 4
Storage Temperature	TST	-20	+60	[°C]	Note 4
Storage Humidity	HST	5	95	[%RH]	Note 4

Note 1: At Ta (25°C)

Note 2: Permanent damage to the device may occur if exceed maximum values

Note 3: LED specification refer to section 5.2

Note 4: For quality performance, please refer to AUO IIS (Incoming Inspection Standard).

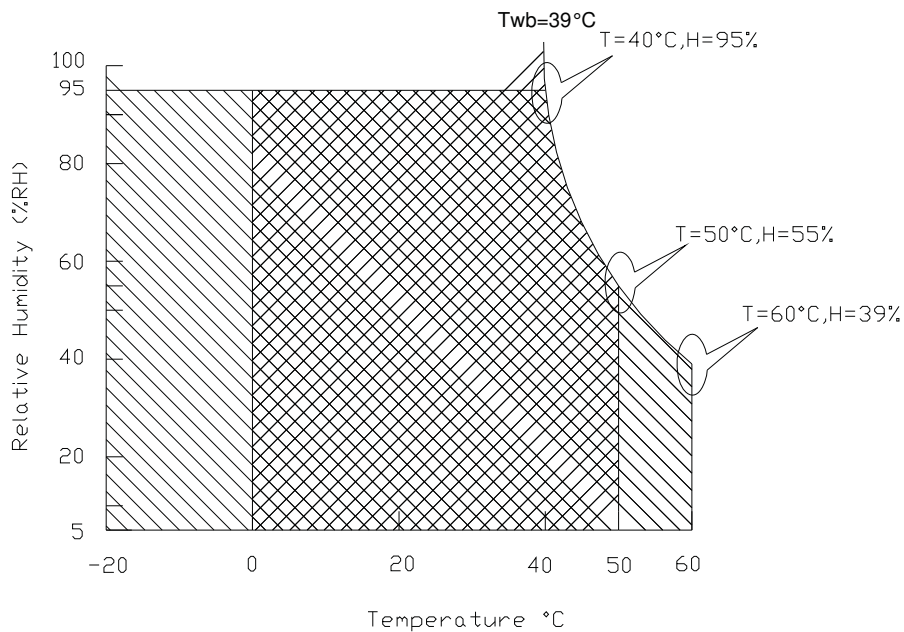

Operating Range 

Storage Range

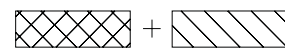



Product Specification

AU OPTRONICS CORPORATION

5. Electrical characteristics

5.1 TFT LCD Module

5.1.1 Power Specification

Input power specifications are as follows:

The power specification are measured under 25°C and frame frequency under 60Hz

Symbol	Parameter	Min	Typ	Max	Units	Note
VDD	Logic/LCD Drive Voltage	3.0	3.3	3.6	[Volt]	
PDD	VDD Power	-	-	2.0	[Watt]	Note 1/2
IDD	IDD Current	-	-	606	[mA]	Note 1/2
IRush	Inrush Current	-	-	2000	[mA]	Note 3
VDDrp	Allowable Logic/LCD Drive Ripple Voltage	-	-	100	[mV] p-p	

Note 1 : Maximum Measurement Condition : Black Pattern, XP Desktop Pattern

Note 2 : Typical Measurement Condition: Mosaic Pattern, XP Desktop Pattern

Note 3 : Measure Condition

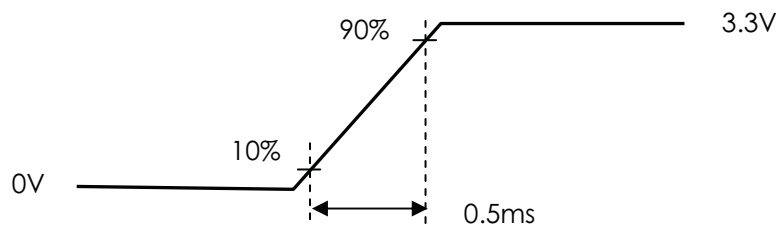
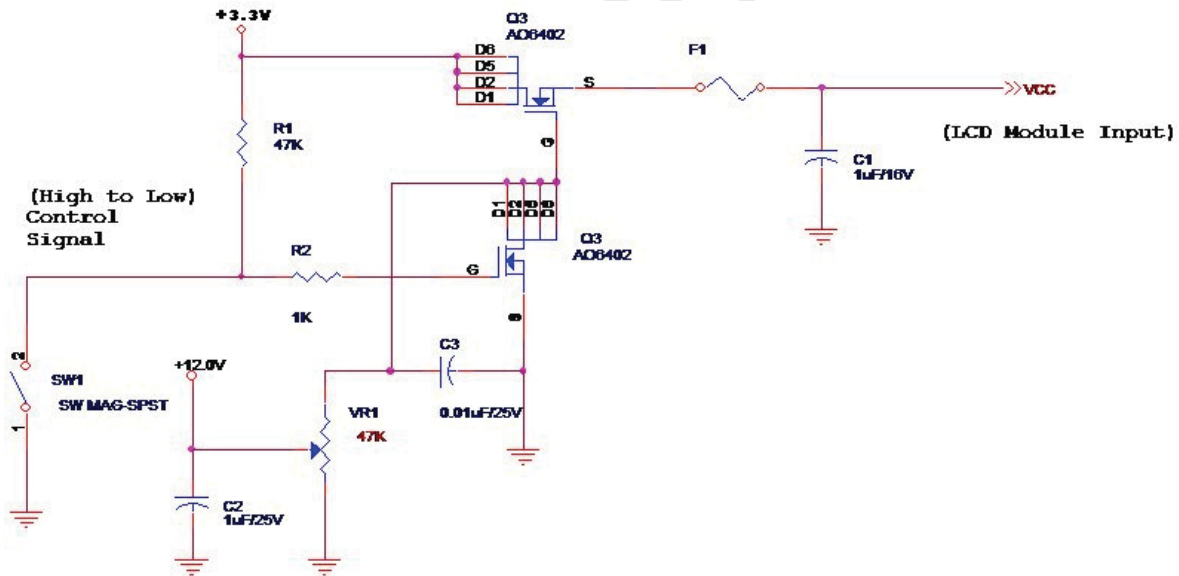

Vin rising time



Product Specification

AU OPTRONICS CORPORATION

5.1.2 Signal Electrical Characteristics

Input signals shall be low or High-impedance state when VDD is off.

Signal electrical characteristics are as follows;

Parameter	Condition	Min	Max	Unit
V_{TH}	Differential Input High Threshold ($V_{cm}=+1.2V$)	-	100	[mV]
V_{TL}	Differential Input Low Threshold ($V_{cm}=+1.2V$)	-100	-	[mV]
$ V_{ID} $	Differential Input Voltage	100	600	[mV]
V_{CM}	Differential Input Common Mode Voltage	1.125	1.375	[V]

Note: LVDS Signal Waveform

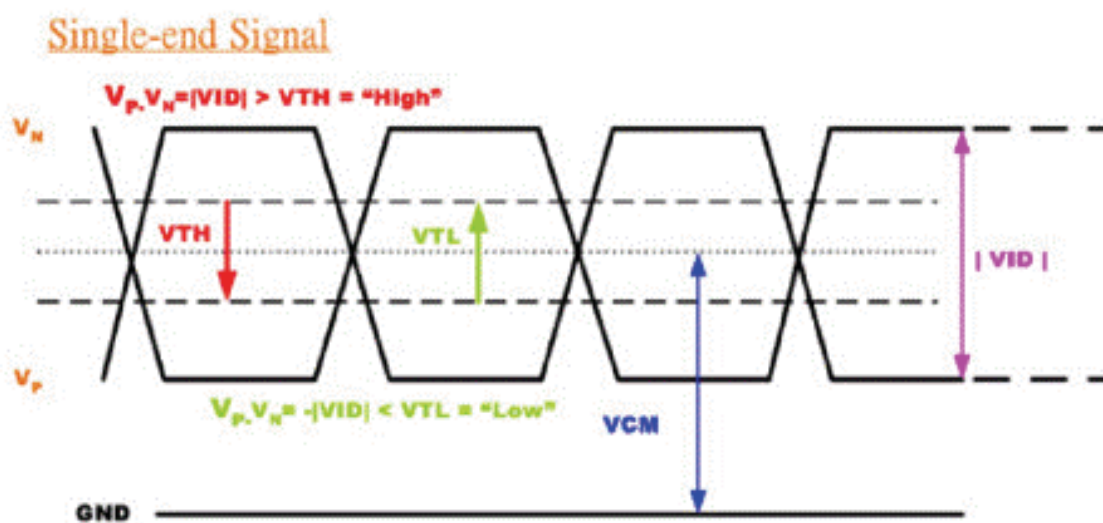



Product Specification

AU OPTRONICS CORPORATION

5.2 Backlight Unit

5.2.1 LED characteristics

Parameter	Symbol	Min	Typ	Max	Units	Condition
Backlight Power Consumption	PLED	-		6.0	[Watt]	(Ta=25°C), Note 1 Vin =12V
LED Life-Time	N/A	10,000	-	-	Hour	(Ta=25°C), Note 2 If=20 mA

Note 1: Calculator value for reference $P_{LED} = VF$ (Normal Distribution) * I_F (Normal Distribution) / Efficiency

Note 2: The LED life-time define as the estimated time to 50% degradation of initial luminous.

5.2.2 Backlight input signal characteristics

Parameter	Symbol	Min	Typ	Max	Units	Remark
LED Power Supply	VLED	7.0	12.0	21.0	[Volt]	Define as Connector Interface (Ta=25°C)
LED Enable Input High Level	VLED_EN	3.0	-	5.5	[Volt]	
LED Enable Input Low Level		-	-	0.8	[Volt]	
PWM Logic Input High Level	VPWM_EN	3.0	-	5.5	[Volt]	
PWM Logic Input Low Level		-	-	0.8	[Volt]	
PWM Input Frequency	FPWM	100	1K	20k	Hz	
PWM Duty Ratio	Duty	5	--	100	%	

Note 1: Calculator Value for refence $I_F \times V_F \times 36$ efficiency (85%) = $P(\text{typ}); P(\text{max})$ estimated with L_f and V_F tolerance.

Note2: The LED life-time define as the estimated time to 50% degradation of iinitial luminous.

Note3: Output PWM frequency < 5k Hz



Product Specification

AU OPTRONICS CORPORATION

6. Signal Characteristic

6.1 Pixel Format Image

Following figure shows the relationship of the input signals and LCD pixel format.

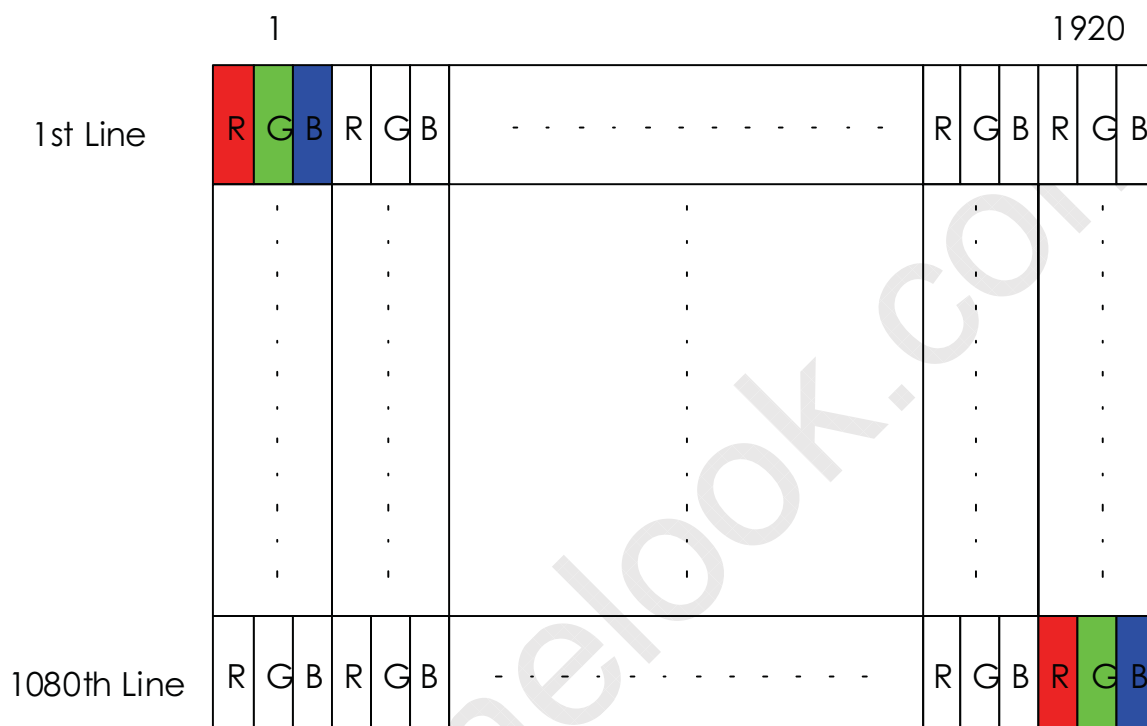



Product Specification

AU OPTRONICS CORPORATION

6.2 The input data format

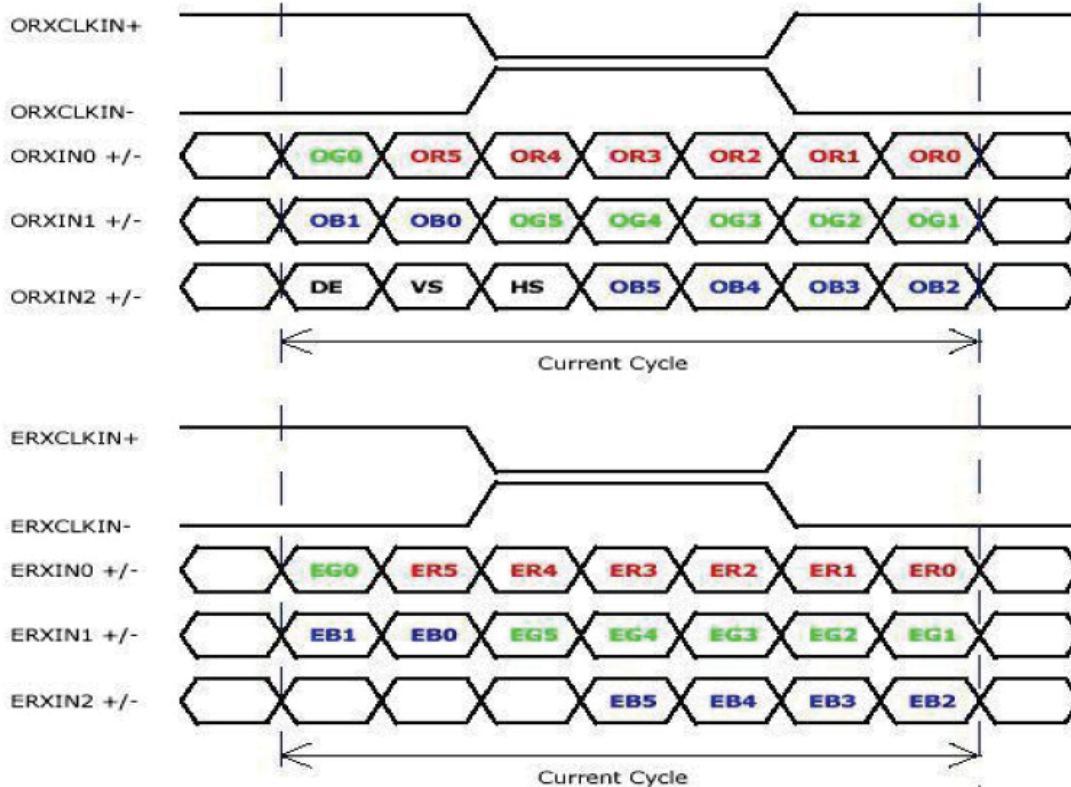

Signal Name	Description	
R5 R4 R3 R2 R1 R0	Red Data 5 (MSB) Red Data 4 Red Data 3 Red Data 2 Red Data 1 Red Data 0 (LSB)	Red-pixel Data Each red pixel's brightness data consists of these 6 bits pixel data.
G5 G4 G3 G2 G1 G0	Green Data 5 (MSB) Green Data 4 Green Data 3 Green Data 2 Green Data 1 Green Data 0 (LSB)	Green-pixel Data Each green pixel's brightness data consists of these 6 bits pixel data.
B5 B4 B3 B2 B1 B0	Blue Data 5 (MSB) Blue Data 4 Blue Data 3 Blue Data 2 Blue Data 1 Blue Data 0 (LSB)	Blue-pixel Data Each blue pixel's brightness data consists of these 6 bits pixel data.
RxCLKIN	Data Clock	The signal is used to strobe the pixel data and DE signals. All pixel data shall be valid at the falling edge when the DE signal is high
DE	Display Timing	This signal is strobed at the falling edge of RxCLKIN. When the signal is high, the pixel data shall be valid to be displayed.
VS	Vertical Sync	The signal is synchronized to RxCLKIN.
HS	Horizontal Sync	The signal is synchronized to RxCLKIN.

Note: Output signals from any system shall be low or High-impedance state when VDD is off.



Product Specification

AU OPTRONICS CORPORATION

6.3 Integration Interface and Pin Assignment

6.3.1 Connector Description

Physical interface is described as for the connector on module.

These connectors are capable of accommodating the following signals and will be following components.

Connector Name / Designation	For Signal Connector
Manufacturer	IPEX or compatible
Type / Part Number	IPEX 20455-040E-12R or compatible
Mating Housing/Part Number	IPEX 20353-040T-11 or compatible

6.3.2 Pin Assignment

LVDS is a differential signal technology for LCD interface and high speed data transfer device.

PIN#	Signal Name	Description
1	NC	No Connection
2	VDD	Power Supply +3.3V
3	VDD	Power Supply +3.3V
4	VEDID	EDID +3.3V Power
5	NC	No Connect (Reserve for M1 aging)
6	CLKEDID	EDID Clock Input
7	DATAEDID	EDID Data Input
8	RxOIN0-	-LVDS Differential Data INPUT(Odd R0-R5,G0)
9	RxOIN0+	+LVDS Differential Data INPUT(Odd R0-R5,G0)
10	VSS	Ground
11	RxOIN1-	-LVDS Differential Data INPUT(Odd G1-G5,B0-B1)
12	RxOIN1+	+LVDS Differential Data INPUT(Odd G1-G5,B0-B1)
13	VSS	Ground
14	RxOIN2-	-LVDS Differential Data INPUT(Odd B2-B5,HS,VS,DE)
15	RxOIN2+	+LVDS Differential Data INPUT(Odd B2-B5,HS,VS,DE)
16	VSS	Ground
17	RxOOCKIN-	-LVDS Odd Differential Clock INPUT
18	RxOOCKIN+	+LVDS Odd Differential Clock INPUT
19	CM_EN	CM_EN
20	RxEIN0-	-LVDS Differential Data INPUT(Even R0-R5,G0)
21	RxEIN0+	+LVDS Differential Data INPUT(Even R0-R5,G0)
22	VSS	Ground
23	RxEIN1-	-LVDS Differential Data INPUT(Even G1-G5,B0-B1)



Product Specification

AU OPTRONICS CORPORATION

24	RxEIN1+	+LVDS Differential Data INPUT(Even G1-G5,B0-B1)
25	VSS	Ground
26	RxEIN2-	-LVDS Differential Data INPUT(Even B2-B5,HS,VS,DE)
27	RxEIN2+	+LVDS Differential Data INPUT(Even B2-B5,HS,VS,DE)
28	VSS	Ground
29	RxECKIN-	-LVDS Even Differential Clock INPUT
30	RxECKIN+	+LVDS Even Differential Clock INPUT
31	VLED_GND	LED Ground
32	VLED_GND	LED Ground
33	VLED_GND	LED Ground
34	NC	No Connection
35	S_PWMIN	System PWM Logic Input level
36	LED_EN	LED enable input level
37	DCR_EN	DCR_EN
38	VLED	LED Power Supply
39	VLED	LED Power Supply
40	VLED	LED Power Supply

Note1: Start from right side



Product Specification

AU OPTRONICS CORPORATION

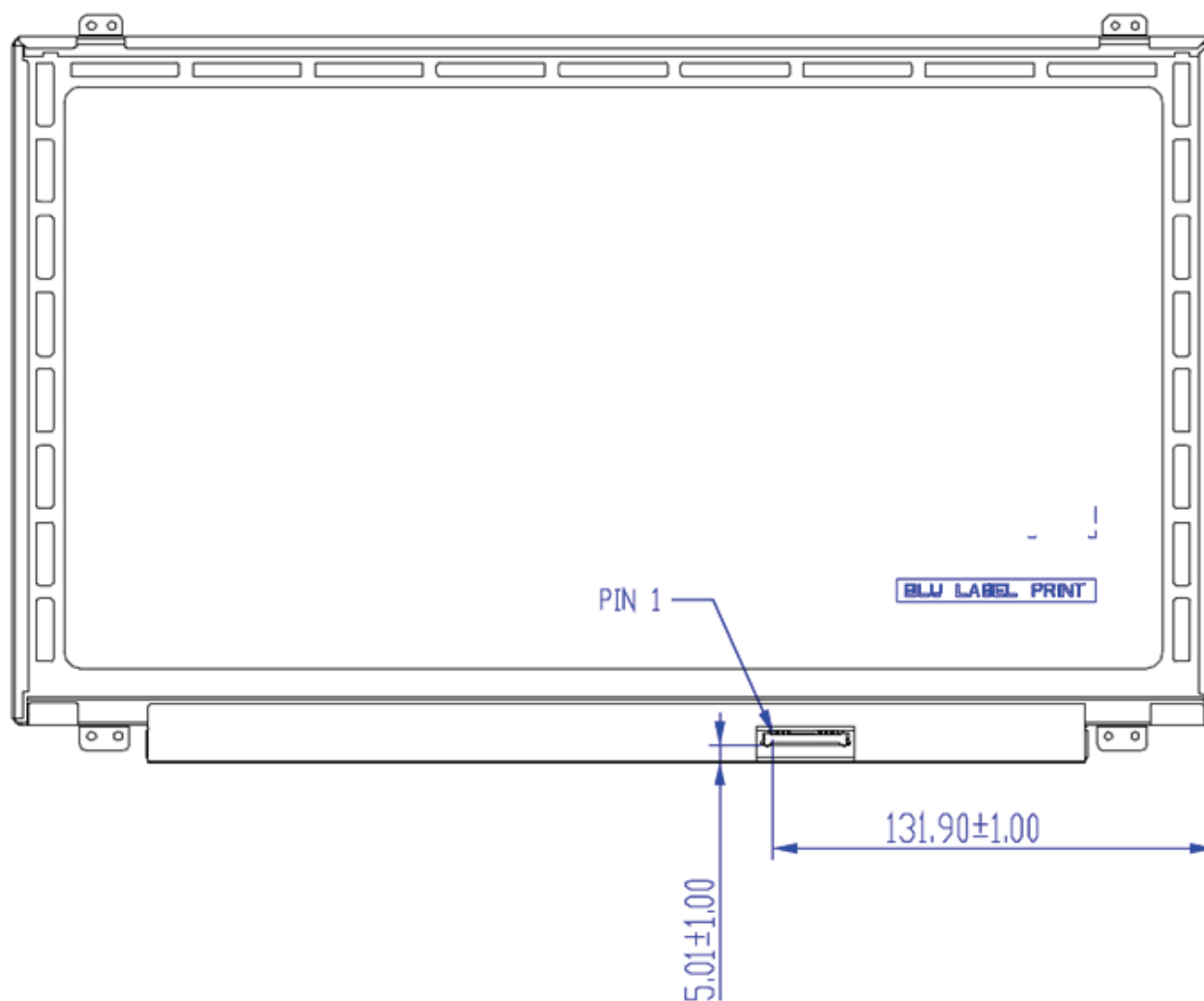

Note2: Input signals shall be low or High-impedance state when VDD is off.

internal circuit of LVDS inputs are as following.

The module uses a 100ohm resistor between positive and negative data lines of each receiver input



Product Specification

AU OPTRONICS CORPORATION

6.4 Interface Timing

6.4.1 Timing Characteristics

Basically, interface timings should match the 1920x1080 /60Hz manufacturing guide line timing.

Parameter	Symbol	Min.	Typ.	Max.	Unit	
Frame Rate	-	40	60	-	Hz	
Clock frequency	$1/T_{\text{Clock}}$	-	70	85	MHz	
Vertical Section	Period	T_V	1088	1130	-	T_{Line}
	Active	T_{VD}	1080			
	Blanking	T_{VB}	8	50	-	
Horizontal Section	Period	T_H	990	1072	-	T_{Clock}
	Active	T_{HD}	960			
	Blanking	T_{HB}	30	112	-	

Note : DE mode only

6.4.2 Timing diagram

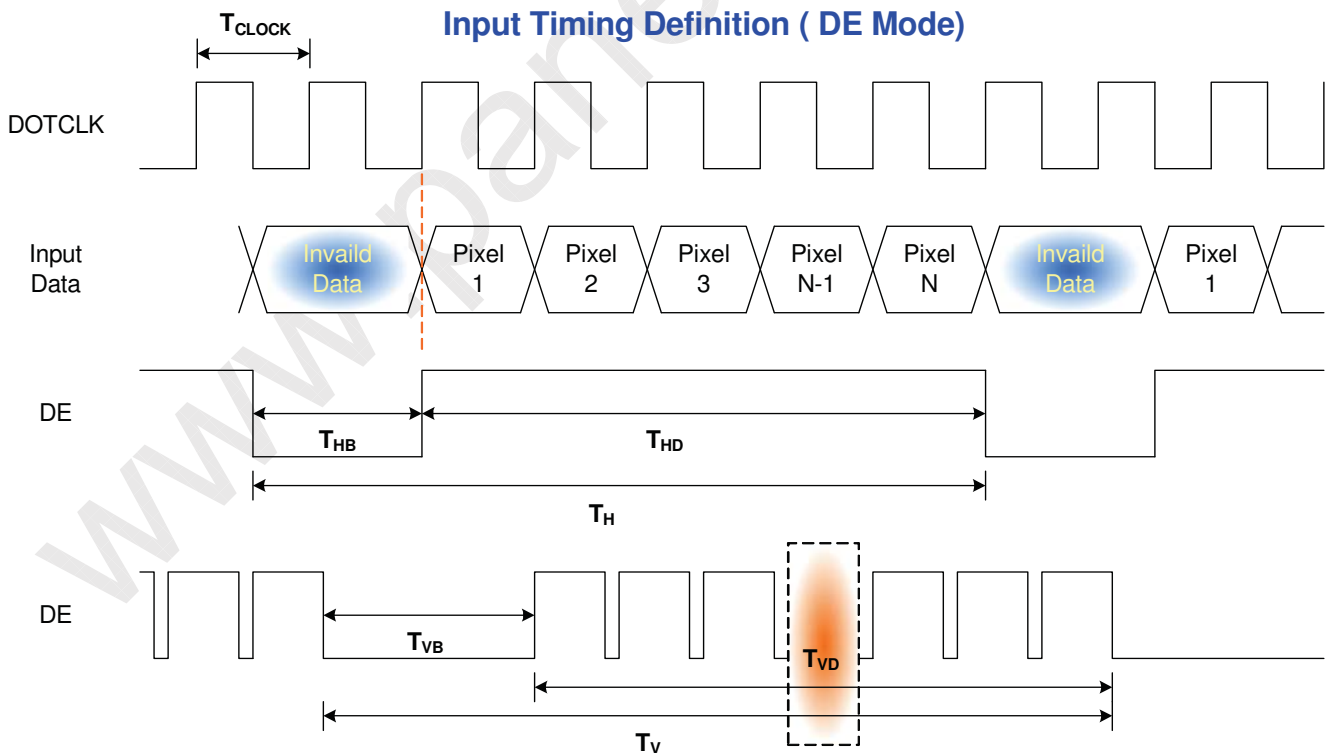



Product Specification

AU OPTRONICS CORPORATION

6.5 Power ON/OFF Sequence

LED on/off sequence is as follows. Interface signals are also shown in the chart.

1) Power on/off sequence

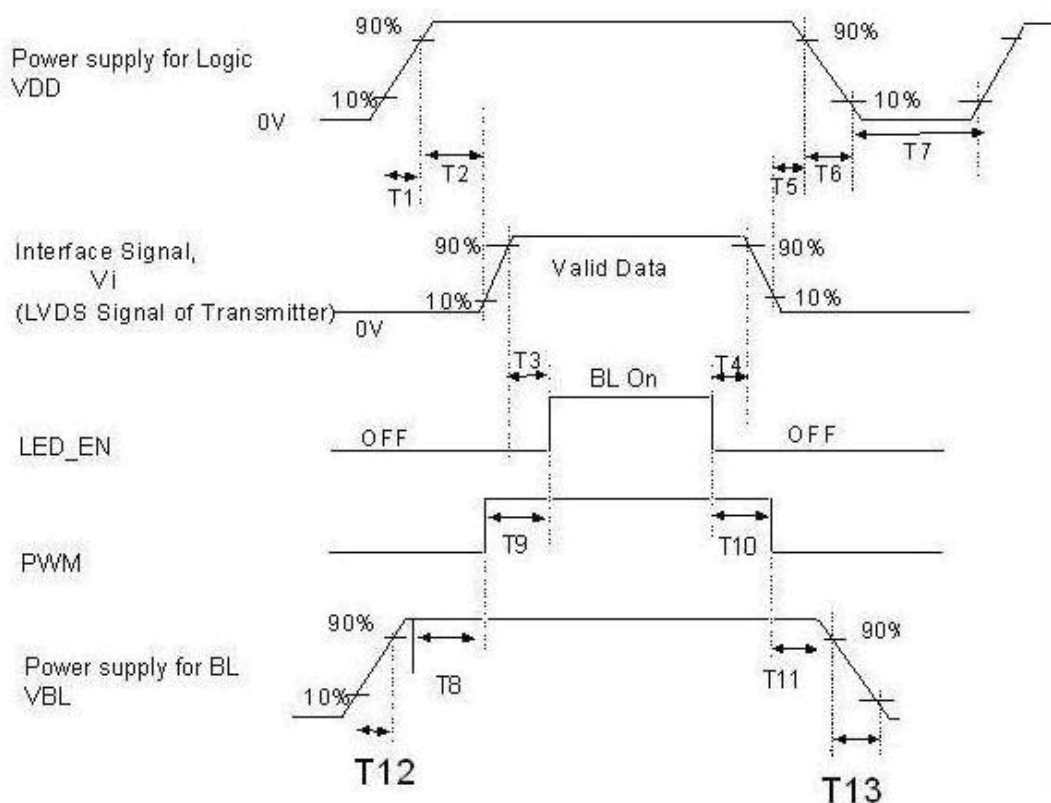

	Min (ms)	Max (ms)
T1	0.5	10
T2	0	50
T3	200	-
T4	200	-
T5	0	50
T6	0	10
T7	500	-
T8	10	-
T9	10	180
T10	10	180
T11	10	-
T12	0.5	10

Note 1 : If $T4 < 200\text{ms}$, The display garbage may occur. We suggest $T4 > 200\text{ms}$ to avoid the display garbage.

Note 2 : If $T1$ or $T12 < 0.5\text{ms}$, the inrush current may cause the damage of fuse. If $T1$ or $T12 < 0.5\text{ms}$, the inrush current I^2t is under typical melt of fuse Spec. , there is no mentioned problem.



Product Specification

AU OPTRONICS CORPORATION

7. Vibration and Shock Test

7.1 Vibration Test

Test Spec:

- Test method: Non-Operation
- Acceleration: 1.5 G
- Frequency: 10 - 500Hz Random
- Sweep: 30 Minutes each Axis (X, Y, Z)

7.2 Shock Test Spec:

Test Spec:

- Test method: Non-Operation
- Acceleration: 220 G , Half sine wave
- Active time: 2 ms
- Pulse: X,Y,Z .one time for each side

7.3. Reliability

Items	Required Condition	Note
Temperature Humidity Bias	Ta= 40°C , 90%RH, 300h	
High Temperature Operation	Ta= 50°C , Dry, 300h	
Low Temperature Operation	Ta= 0°C , 300h	
High Temperature Storage	Ta= 60°C , 35%RH, 300h	
Low Temperature Storage	Ta= -20°C , 50%RH, 300h	
Thermal Shock Test	Ta=-20°C to 60°C , Duration at 30 min, 100 cycles	
ESD	Contact : ±8 KV Air : ±15 KV	Note 1

Note1: According to EN 61000-4-2 , ESD class B: Some performance degradation allowed. No data lost . Self-recoverable. No hardware failures.

Remark: MTBF (Excluding the LED): 30,000 hours with a confidence level 90%



Product Specification

AU OPTRONICS CORPORATION

8. Mechanical Characteristics

8.1 LCM Outline Dimension

8.1.1 Standard Front View

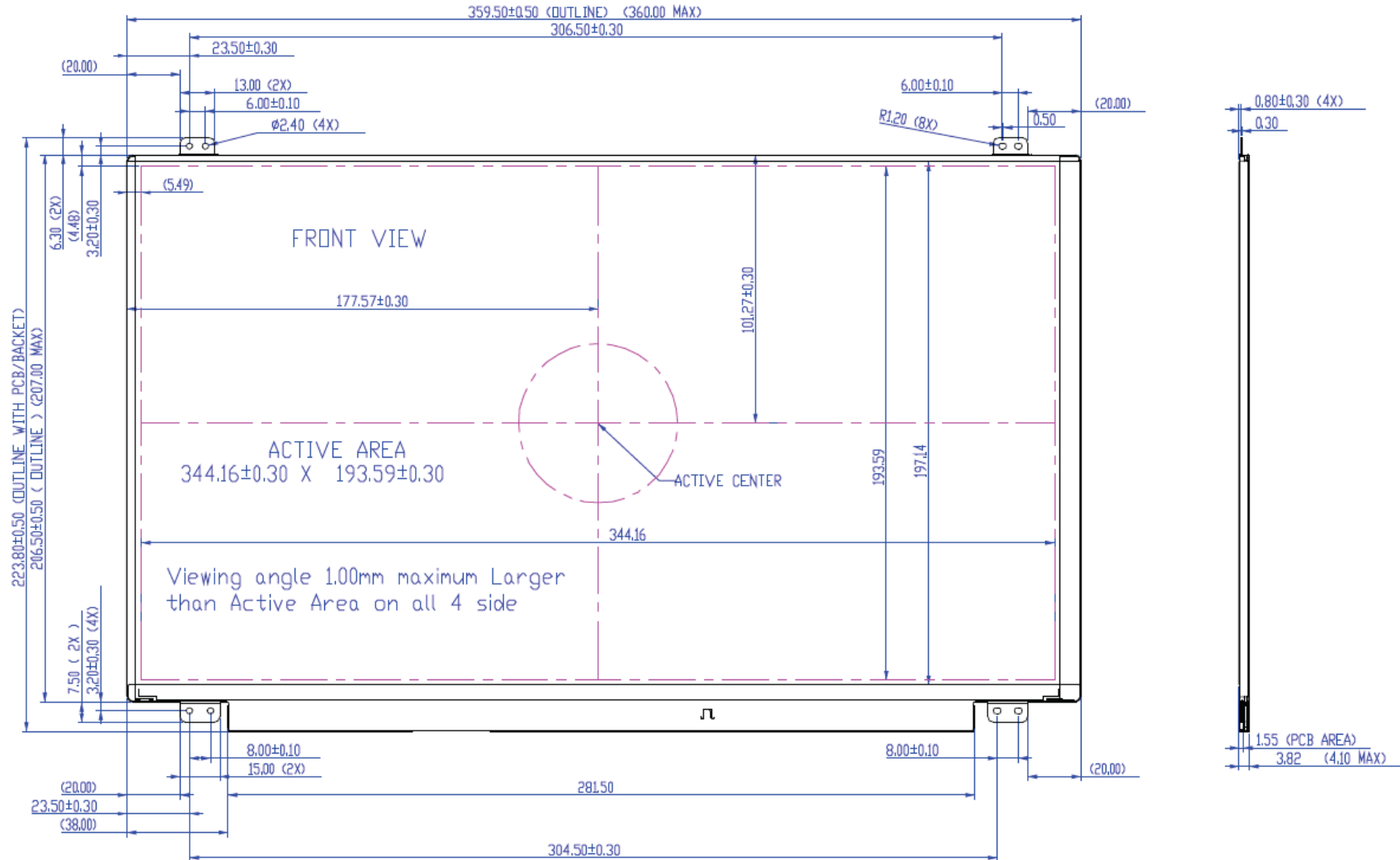



Product Specification

AU OPTRONICS CORPORATION

8.1.2 Standard Rear View

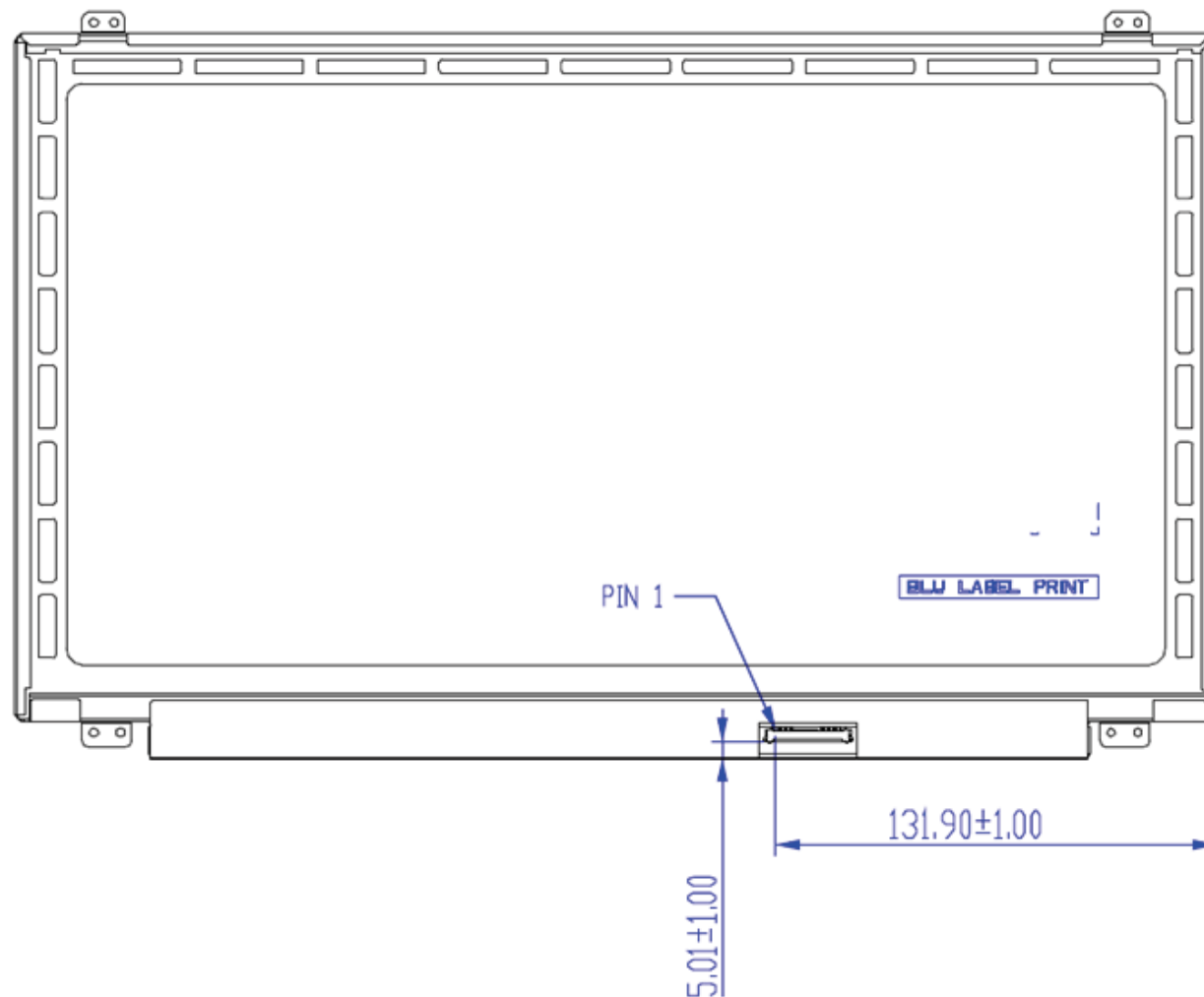



Product Specification

AU OPTRONICS CORPORATION

9. Shipping and Package

9.1 Shipping Label Format

 XXXXXXXXXXXXX-XXXXX	Manufactured YY/MM Model No: B156HW03 V0 AU Optronics MADE IN CHINA (S1)
 CN-0NCDF3-72090- XXX-XXXX-A00 Made In China DP/N 0NCDF3	H/W: 0A F/W:1

9.2 Definition of customer PPID Label and Revision Code

Please refer to the Dell Part identification Label Specification, Number:13190

Build Name(s):	PPID Revision Code(s):
Sub System Test (SST) Working Sample (WS) ENG 2	X00, X01, X02, ..., X0n
Product Test (PT) Engineering Sample (ES) ENG 3	X10, X11, X12, ..., X1n
System Test (ST) Customer Sample (CS) ENG 4	X20, X21, X22, ... X2n
X-Build (XB) Mass Production (MP) ENG 5	A00, A01, A02, ... A0n



Product Specification

AU OPTRONICS CORPORATION

9.2. Carton package

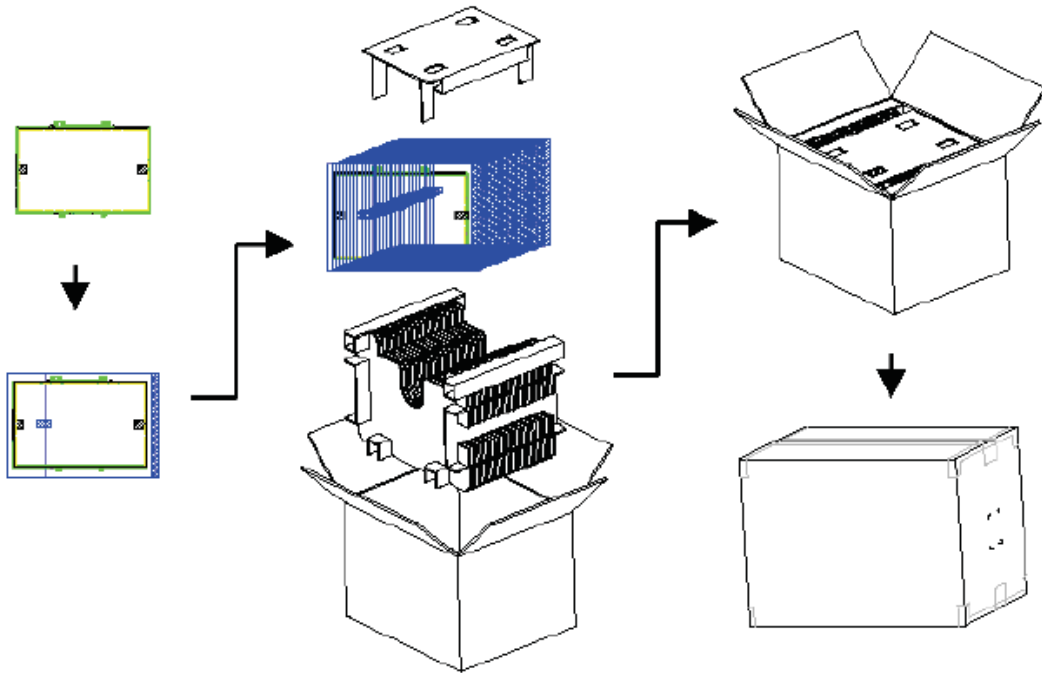

9.3 Shipping package of palletizing sequence

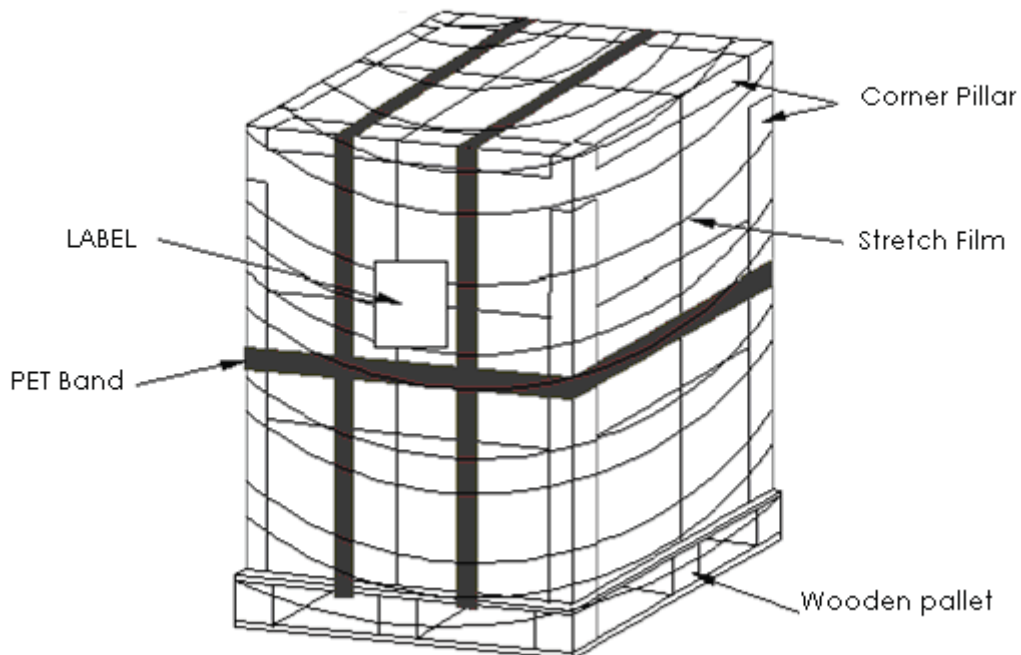



Product Specification

AU OPTRONICS CORPORATION

10. Appendix: EDID description

	Byte	Field Name and Comments	Value	Value	Value
	(hex)		(hex)	(binary)	(DEC)
Header	0	Header	00	00000000	0
	1	Header	FF	11111111	255
	2	Header	FF	11111111	255
	3	Header	FF	11111111	255
	4	Header	FF	11111111	255
	5	Header	FF	11111111	255
	6	Header	FF	11111111	255
	7	Header	00	00000000	0
Vendor / Product EDID Version	8	EISA manufacture code = 3 Character ID	06	00000110	6
	9	EISA manufacture code (Compressed ASCII)	AF	10101111	175
	0A	Panel Supplier Reserved – Product Code	ED	11101101	237
	0B	Panel Supplier Reserved – Product Code	30	00110000	48
	0C	LCD module Serial No - Preferred but Optional (“0” if not used)	00	00000000	0
	0D	LCD module Serial No - Preferred but Optional (“0” if not used)	00	00000000	0
	0E	LCD module Serial No - Preferred but Optional (“0” if not used)	00	00000000	0
	0F	LCD module Serial No - Preferred but Optional (“0” if not used)	00	00000000	0
	10	Week of manufacture	00	00000000	0
	11	Year of manufacture	14	00010100	20
	12	EDID structure version # = 1	01	00000001	1
	13	EDID revision # = 4	04	00000100	4
Display Parameters	14	Video I/P definition	90	10010000	144
	15	Max H image size = ?? cm(Rounded to cm)	22	00100010	34
	16	Max V image size = ?? cm(Rounded to cm)	13	00010011	19
	17	Display gamma = (gamma ×100)-100 = Example: (2.2×100) – 100 = 120	78	01111000	120
	18	Feature support	02	00000010	2
Panel Color Coordinates	19	Red/Green Low bit (RxRy/GxGy)	D1	11010001	209
	1A	Blue/White Low bit (BxBY/WxWy)	15	00010101	21
	1B	Red X Rx = 0.???	9E	10011110	158
	1C	Red Y Ry = 0.???	59	01011001	89
	1D	Green X Rx = 0.???	53	01010011	83
	1E	Green Y Ry = 0.???	9B	10011011	155
	1F	Blue X Rx = 0.???	27	00100111	39
	20	Blue Y Ry = 0.???	1E	00011110	30
	21	White X Rx = 0.???	50	01010000	80



Product Specification

AU OPTRONICS CORPORATION

	22	White Y Ry = 0.???	54	01010100	84
Established Timings	23	Established timings 1 (00h if not used)	00	00000000	0
	24	Established timings 2 (00h if not used)	00	00000000	0
	25	Manufacturer's timings (00h if not used)	00	00000000	0
Standard Timing ID	26	Standard timing ID1 (01h if not used)	01	00000001	1
	27	Standard timing ID1 (01h if not used)	01	00000001	1
	28	Standard timing ID2 (01h if not used)	01	00000001	1
	29	Standard timing ID2 (01h if not used)	01	00000001	1
	2A	Standard timing ID3 (01h if not used)	01	00000001	1
	2B	Standard timing ID3 (01h if not used)	01	00000001	1
	2C	Standard timing ID4 (01h if not used)	01	00000001	1
	2D	Standard timing ID4 (01h if not used)	01	00000001	1
	2E	Standard timing ID5 (01h if not used)	01	00000001	1
	2F	Standard timing ID5 (01h if not used)	01	00000001	1
	30	Standard timing ID6 (01h if not used)	01	00000001	1
	31	Standard timing ID6 (01h if not used)	01	00000001	1
	32	Standard timing ID7 (01h if not used)	01	00000001	1
	33	Standard timing ID7 (01h if not used)	01	00000001	1
	34	Standard timing ID8 (01h if not used)	01	00000001	1
	35	Standard timing ID8 (01h if not used)	01	00000001	1
	Timing Descriptor #1	36	Pixel Clock/10,000 (LSB)	B0	10110000
37		Pixel Clock/10,000 (MSB)	36	00110110	54
38		Horizontal Active = ???? pixels (lower 8 bits)	80	10000000	128
39		Horizontal Blanking (Thbp) = 320 pixels (lower 8 bits)	E0	11100000	224
3A		Horizontal Active/Horizontal blanking (Thbp) (upper4:4 bits)	70	01110000	112
3B		Vertical Active = ??? lines	38	00111000	56
3C		Vertical Blanking (Tvbp) = ?? lines (DE Blanking typ. for DE only panels)	08	00001000	8
3D		Vertical Active : Vertical Blanking (Tvbp) (upper4:4 bits)	40	01000000	64
3E		Horizontal Sync, Offset (Thfp) = ?? pixels	30	00110000	48
3F		Horizontal Sync, Pulse Width = ??? pixels	64	01100100	100
40		Vertical Sync, Offset (Tvfp) = ? lines Sync Width = ? lines	31	00110001	49
41		Horizontal Vertical Sync Offset/Width upper 2 bits	00	00000000	0
42		Horizontal Image Size = ??? mm	58	01011000	88
43		Vertical image Size = ??? mm	C1	11000001	193
44		Horizontal Image Size / Vertical image size	10	00010000	16
B156HW03	45	Horizontal Border = 0 (Zero for Notebook)	00	00000000	0



Product Specification

AU OPTRONICS CORPORATION

	LCD)			
46	Vertical Border = 0 (Zero for Notebook LCD)	00	00000000	0
47	Bit[7] 0: Non-interlace, 1: Interlace Bit[6:5] 00: Normal display, no stereo, see VESA EDID Spec 1.3 Bit[4:3] 00: Analog composite, 01: Bipolar analog composite, 10: Digital composite, 11: Digital separate Bit[2:1] : The interpretation of bits 2 and 1 is dependent on the decode of bits 4 and 3 - see VESA EDID Spec 1.3 Bit[0] : See VESA EDID Spec 1.3 ==> fix=1A	1A	00011010	26
48	Pixel Clock/10,000 (LSB)	75	01110101	117
49	Pixel Clock/10,000 (MSB)	24	00100100	36
4A	Horizontal Active = xxxx pixels (lower 8 bits)	80	10000000	128
4B	Horizontal Blanking (Thbp) = xxxx pixels (lower 8 bits)	E0	11100000	224
4C	Horizontal Active/Horizontal blanking (Thbp) (upper 4:4 bits)	70	01110000	112
4D	Vertical Active = xxxx lines	38	00111000	56
4E	Vertical Blanking (Tvbp) = xxxx lines (DE Blanking typ. for DE only panels)	08	00001000	8
4F	Vertical Active : Vertical Blanking (Tvbp) (upper 4:4 bits)	40	01000000	64
50	Horizontal Sync, Offset (Thfp) = xxxx pixels	30	00110000	48
51	Horizontal Sync, Pulse Width = xxxx pixels	64	01100100	100
52	Vertical Sync, Offset (Tvfp) = xx lines Sync Width = xx lines	31	00110001	49
53	Horizontal Vertical Sync Offset/Width upper 2 bits	00	00000000	0
54	Horizontal Image Size = xxx mm	58	01011000	88
55	Vertical image Size = xxx mm	C1	11000001	193
56	Horizontal Image Size / Vertical image size	10	00010000	16
57	Horizontal Border = 0 (Zero for Notebook LCD)	00	00000000	0
58	Vertical Border = 0 (Zero for Notebook LCD)	00	00000000	0

Timing Descriptor #2
(=Timing Descriptor #1)



Product Specification

AU OPTRONICS CORPORATION

	59	Bit[7] 0: Non-interlace, 1: Interlace Bit[6:5] 00: Normal display, no stereo, see VESA EDID Spec 1.3 Bit[4:3] 00: Analog composite, 01: Bipolar analog composite, 10: Digital composite, 11: Digital separate Bit[2:1] : The interpretation of bits 2 and 1 is dependent on the decode of bits 4 and 3 - see VESA EDID Spec 1.3 Bit[0] : See VESA EDID Spec 1.3 ==> fix=1A	1A	00011010	26
Timing Descriptor #3 Dell specific information	5A	Flag	00	00000000	0
	5B	Flag	00	00000000	0
	5C	Flag	00	00000000	0
	5D	Data Type Tag: Alphanumeric Data String (ASCII) ==> fix=FE	FE	11111110	254
	5E	Flag	00	00000000	0
	5F	Dell P/N 1st Character	4E	01001110	78
	60	Dell P/N 2nd Character	43	01000011	67
	61	Dell P/N 3rd Character	44	01000100	68
	62	Dell P/N 4th Character	46	01000110	70
	63	Dell P/N 5th Character	33	00110011	51
	64	EDID Revision Bit[6:0] See charts below Bit[7] 0: X-rev, 1: A-rev	80	10000000	128
	65	Manufacturer P/N	42	01000010	66
	66	Manufacturer P/N	31	00110001	49
	67	Manufacturer P/N	35	00110101	53
	68	Manufacturer P/N	36	00110110	54
	69	Manufacturer P/N	48	01001000	72
6A	Manufacturer P/N	57	01010111	87	
6B	Manufacturer P/N (If <13 char, then terminate with ASCII code 0Ah, set remaining char = 20h)	33	00110011	51	
Timing Descriptor #4	6C	Flag	00	00000000	0
	6D	Flag	00	00000000	0
	6E	Flag	00	00000000	0
	6F	Data Type Tag: Manufacturer Specified Data 00 ==>fix=00	00	00000000	0
	70	Flag	00	00000000	0
	71	Color Management	00	00000000	0
	72	Panel Structure	41	01000001	65
	73	Frame Rate	22	00100010	34
74	Light Controller Interface and Luminance	96	10010110	150	



Product Specification

AU OPTRONICS CORPORATION

	75	Outdoor Features	01	00000001	1
	76	Multi-Media Features	11	00010001	17
	77	Multi-Media Features	00	00000000	0
	78	Special Features #1	00	00000000	0
	79	Special Features #2	02	00000010	2
	7A	Special Features #3	01	00000001	1
	7B	(If <13 char, then terminate with ASCII code 0Ah, set remaining char = 20h)	0A	00001010	10
	7C	(If <13 char, then terminate with ASCII code 0Ah, set remaining char = 20h)	20	00100000	32
	7D	(If <13 char, then terminate with ASCII code 0Ah, set remaining char = 20h)	20	00100000	32
Checksum	7E	Extension flag (# of optional 128 EDID extension blocks to follow, Typ = 0)	00	00000000	0
	7F	Checksum (The 1-byte sum of all 128 bytes in this EDID block shall = 0)	15	00010101	21