



Product Specification

AU OPTRONICS CORPORATION

() Preliminary Specifications

(V) Final Specifications

Module	16" FHD 16:9 Color TFT-LCD with LED Backlight design
Model Name	B160HW02 V0 (HW Code: 1A)

Customer	Date
Checked & Approved by	Date
<p>Note: This Specification is subject to change without notice.</p>	

Approved by	Date
<u>Kuei Sheng Tseng</u>	<u>2010/6/30</u>
Prepared by	Date
<u>Michael WJ Sun</u>	<u>2010/6/30</u>
NBBU Marketing Division AU Optronics corporation	



Product Specification

AU OPTRONICS CORPORATION

Contents

1. Handling Precautions	5
2. General Description	6
2.1 General Specification	6
2.2 Optical Characteristics	7
3. Functional Block Diagram	12
4. Absolute Maximum Ratings	13
4.1 Absolute Ratings of TFT LCD Module.....	13
4.2 Absolute Ratings of Environment	13
5. Electrical Characteristics	14
5.1 TFT LCD Module.....	14
5.2 Backlight Unit.....	17
6. Signal Interface Characteristic	19
6.1 Pixel Format Image.....	19
6.2 Integration Interface Requirement	21
6.3 Interface Timing.....	23
6.4 Power ON/OFF Sequence.....	27
7. Panel Reliability Test	29
7.1 Vibration Test	29
7.2 Shock Test.....	29
7.3 Reliability Test	29
8. Mechanical Characteristics	30
8.1 LCM Outline Dimension	30
9. Shipping and Package	32
9.1 Shipping Label Format.....	33
9.2 Carton Package.....	34
9.3 Shipping Package of Palletizing Sequence	35
10. Appendix	36
10.1 EDID Description	36



Product Specification

AU OPTRONICS CORPORATION

Record of Revision

Version and Date	Page	Old description	New Description	Remark
0.1 2010/09/07	All	First Edition for Customer		
0.2 2010/11/01	5	White Luminance 2D animation/3D : 230 cd/m ² typ	224 cd/m ² typ	
		Luminance Uniformity 2D animation/3D : 65% typ	50% typ	
		Power Consumption : 18.8 / 24.9 Watt max (Include Logic and BLU power)	Please refer to 5.1.1 and 5.2.1	
		Module thickness : 8.5mm	Module thickness : 8.95mm	
		Weight : 632g typ	638g typ	
	6	Surface Treatment : Glare	Surface Treatment : Anti-Glare	
		Revise 2.2 Optical Characteristics	Please refer to revised version	
	11	Update absolute ratings of TFT LCD module : V_{DD5} , V_{in} , V_{LED} , I_{LED}	V_{DD5} : -0.3~+6.5V V_{in} : -0.3~(V_{DD33} +0.3)V V_{LED} : -0.3~22V I_{LED} : 0~30mA	
		Update absolute ratings of environment: Operating Temperature : 0~50°C	Operating Temperature : 0~50°C	
	12	Update power specification of IDD33, IDD5 and delete inrush current and VDD ripple	Please refer to p12	
	15,16	Update LED characteristics and backlight input signal characteristics	Please refer to p15~p16	
	24,25	Update 6.5 Power ON/OFF Sequence	Please refer to p24~25	
	27,28	Update module appearance	Please refer to p27~p28	
	33	Update EDID description	Please refer to p33~p38	
1.0 2011/1/17	All		Final the spec	
	8	none	Note 2: Luminance measure point	
	9	Note 7: Definition of response time	Please refer to p9	
	13	Update current of the Input power	Please refer to p13	
	15	VHPD :2.25(min); 3.6(max)	VHPD :1.9(min); 2.7(max)	
	21~2 3	Timing Characteristics	Please refer to p21~p23	



Product Specification

AU OPTRONICS CORPORATION

	27	Vibration: 10~500Hz	Vibration: 5~500Hz	
		Shock: 220G, 2ms	Shock: 210G, 3ms	
	30	Update pictures	Please refer to p30	
1.1 2011/2/17	7	Add light distribution	Please refer to p7	
	16	Update the description of the Note1 and Note2	Please refer to p16	
	23	Update 3D timing	Please refer to p23	
	27	Add the test and condition of the High Temperature and High Humidity Storage	Please refer to p27	
1.2 2011/6/29	6	Weight : 638g typ	648g typ \pm 30g	
	31	Update pictures and shipping label	Please refer to p31	
	32	Update pictures	Please refer to p32	



Product Specification

AU OPTRONICS CORPORATION

1. Handling Precautions

- 1) Since front polarizer is easily damaged, pay attention not to scratch it.
- 2) Be sure to turn off power supply when inserting or disconnecting from input connector.
- 3) Wipe off water drop immediately. Long contact with water may cause discoloration or spots.
- 4) When the panel surface is soiled, wipe it with absorbent cotton or other soft cloth.
- 5) Since the panel is made of glass, it may break or crack if dropped or bumped on hard surface.
- 6) Since PMOS is used in this module, take care of static electricity and insure human earth when handling.
- 7) Do not open nor modify the Module Assembly.
- 8) Do not press the reflector sheet at the back of the module to any directions.
- 9) At the insertion or removal of the Signal Interface Connector, be sure not to rotate nor tilt the Interface Connector of the TFT Module.
- 11) After installation of the TFT Module into an enclosure (Notebook PC Bezel, for example), do not twist nor bend the TFT Module even momentary. At designing the enclosure, it should be taken into consideration that no bending/twisting forces are applied to the TFT Module from outside. Otherwise the TFT Module may be damaged.
- 12) Small amount of materials having no flammability grade is used in the LCD module. The LCD module should be supplied by power complied with requirements of Limited Power Source (IEC60950 or UL1950), or be applied exemption.
- 13) Disconnecting power supply before handling LCD modules, it can prevent electric shock, DO NOT TOUCH the electrode parts, cables, connectors and LED circuit part of TFT module that a LED light bar build in as a light source of back light unit. It can prevent electrostatic breakdown.



Product Specification

AU OPTRONICS CORPORATION

2. General Description

B160HW02 V0 is a Color Active Matrix Liquid Crystal Display composed of a TFT LCD panel, a driver circuit, and LED backlight system. The screen format is intended to support the 16:9 FHD, 1920(H) x1080(V) screen and 262k colors (RGB 6-bits data driver) with LED backlight driving circuit. All input signals are eDP interface compatible.

B160HW02 V0 is designed for a display unit of notebook style personal computer and industrial machine.

2.1 General Specification

The following items are characteristics summary on the table at 25 °C condition:

Items	Unit	Specifications			
Screen Diagonal	[mm]	406.4			
Active Area	[mm]	354.24X199.26			
Pixels H x V		1920x3(RGB) x 1080			
Pixel Pitch	[mm]	0.1845X0.1845			
Pixel Format		R.G.B. Vertical Stripe			
Display Mode		Normally White			
White Luminance 2D still picture (ILED=20mA)	[cd/m ²]	345 typ.			
White Luminance 2D animation/3D (ILED=27mA / 45% duty)	[cd/m ²]	224 typ.			
Luminance Uniformity 2D still picture	[%]	65 typ.			
Luminance Uniformity 2D animation/3D	[%]	50 typ.			
Contrast Ratio		500 typ.			
Response Time	[ms]	4 Max			
Nominal Input Voltage VDD	[Volt]	+3.3 / +5.0 typ.			
Weight	[Grams]	648 typ.± 30			
Physical Size Include bracket & PCBA	[mm]		Min.	Typ.	Max.
		Length	-	375.0	-
		Width	-	218.0	-
		Thickness	-	-	8.95
Electrical Interface		eDP			
Glass Thickness	[mm]	0.5			
Surface Treatment		Anti-Glare			



Product Specification

AU OPTRONICS CORPORATION

Support Color		262K colors (RGB 6-bit)
Temperature Range		
Operating	[°C]	0 to +50
Storage (Non-Operating)	[°C]	-20 to +60

2.2 Optical Characteristics

The optical characteristics are measured under stable conditions at 25°C (Room Temperature) :

Item	Symbol	Conditions	Min.	Typ.	Max.	Unit	Note
Luminance 2D still picture	[cd/m ²]	$\theta = 0^\circ, \phi = 0^\circ$ Gray Scale Level=L63 (White)	242	345			1, 2 $I_{LED} = 20\text{mA}(\text{rm})$
Luminance 2D animation/3D	[cd/m ²]	$\theta = 0^\circ, \phi = 0^\circ$ Gray Scale Level=L63 (White)	157	224			1, 2 $I_{LED} = 27\text{mA}(\text{rms})$ 45% duty
Viewing Angle	θ_R	Horizontal (Right) CR = 10 (Left)	80	-	-	degree	5, 8
	θ_L		80	-	-		
	ϕ_H	Vertical (Upper) CR = 10 (Lower)	80	-	-	-	
	ϕ_L		80	-	-		
Light distribution	θ	L = 1/2 Lstill	Vertical	29.5	34.5		degree
			Horizontal	47.0	52.0		degree
Luminance Uniformity 2D still picture	Lstill	$\theta = 0^\circ, \phi = 0^\circ$ Gray Scale Level=L63 (White)	55	65			1, 3, 4
Luminance Uniformity 2D animation/3D	L3D	$\theta = 0^\circ, \phi = 0^\circ$ Gray Scale Level=L63 (White)	40	50			1, 3, 4
Contrast Ratio	CR		300	500	-		5, 6
Response Time	T_r	Rising	-	-	-	msec	5, 7
	T_f	Falling	-	-	-		
	T_{RT}	Rising + Falling	-	-	4		
Color / Chromaticity Coordinates	Red	Rx	CIE 1931	0.5981	0.6481	0.6977	5
		Ry		0.2867	0.3366	0.3847	
	Green	Gx		0.2464	0.2964	0.3460	
		Gy		0.5922	0.6421	0.6902	
	Blue	Bx		0.0927	0.1427	0.1923	
		By		0.0000	0.0383	0.0864	
	White	Wx		0.2675	0.3175	0.3671	
		Wy		0.2680	0.3179	0.3660	
	NTSC (u'v')	%			-	100	
2D Image sticking		Immediately after ageing	There must not be image sticking in the entire checker pattern				9



Product Specification

AU OPTRONICS CORPORATION

3D Image sticking	Gray(L31) is displayed for 30minutes after againg	No image sticking	Using 13% NC filter
	Immediately after againg	There must not be image sticking in the entire checker pattern	9
	Gray(L31) is displayed for 30minutes after againg	No image sticking	Using 13% NC filter

Note 1: Turn off the white balance and measure it.

Note 2: Luminance measure point

2D still: The average value of the brightness of five points.

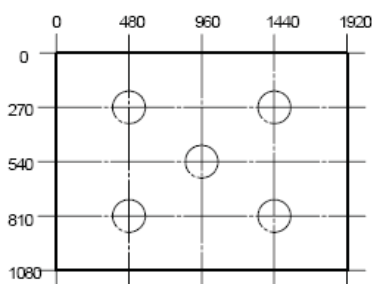

2D animation/ 3D: The brightness of center point

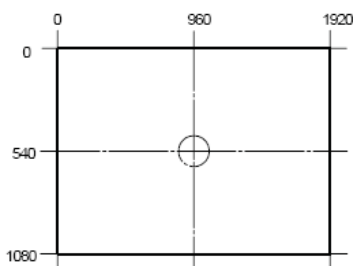

Note 3: The above test limit must be applied for initial use. Characteristics will be shifted by long period operation, but it is not irregular phenomena. Theoretically brightness characteristics will be decreased due to LED degradation and color shift due to optical components change.

Note 4: 9 positions position (Ref: Active area)



Product Specification

AU OPTRONICS CORPORATION

The Luminance should be measured at 9 positions on white raster(gray scale level L63).
Uniformity can be calculated by the following expression.

$$\text{Luminance Uniformity} = \frac{\text{Minimum Luminance}}{\text{Maximum Luminance}} \times 100\%$$

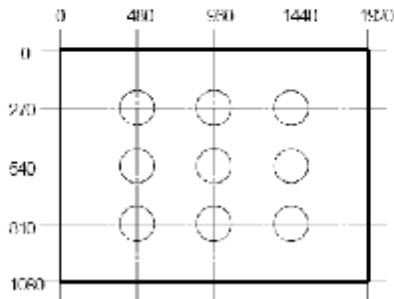

Note 5: Measurement method

The LCD module should be stabilized at given temperature for 30 minutes to avoid abrupt temperature change during measuring. In order to stabilize the luminance, the measurement should be executed after lighting Backlight for 30 minutes in a stable, windless and dark room, and it should be measured in the center of screen.

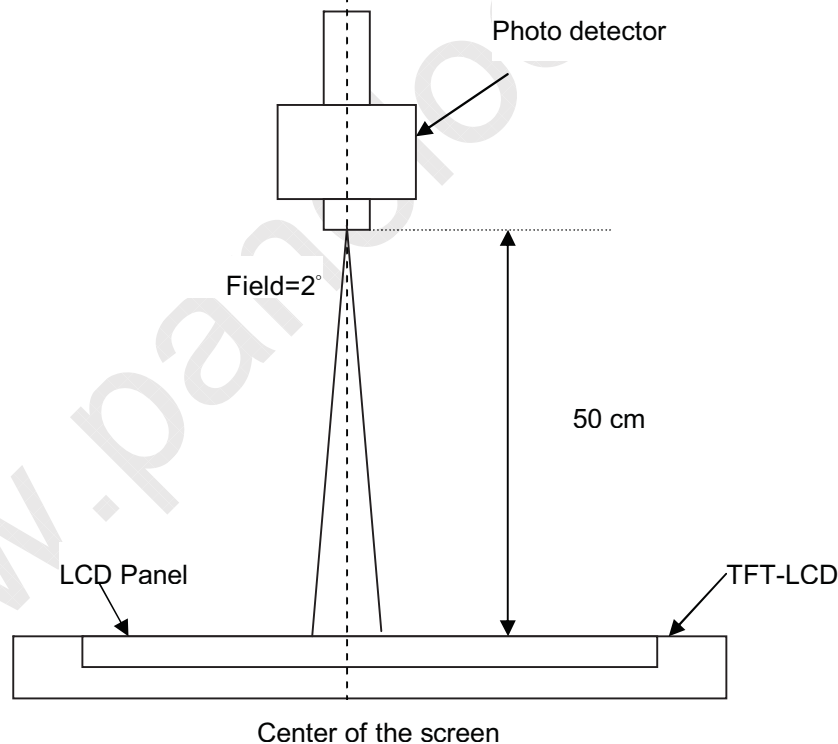

Note 6 : Definition of contrast ratio:

Contrast ratio is calculated with the following formula.

$$\text{Contrast ratio (CR)} = \frac{\text{Brightness on the "White" state}}{\text{Brightness on the "Black" state}}$$

Note 7: Definition of response time: measured by Westar TRD-100A

The output signals of photo detector are measured when the input signals are changed from "Black" to



Product Specification

AU OPTRONICS CORPORATION

“White” (rising time, Tr_R), and from “White” to “Black” (falling time, Tr_F), respectively. The response time is interval between the 10% and 90% of amplitudes. Refer to figure as below.

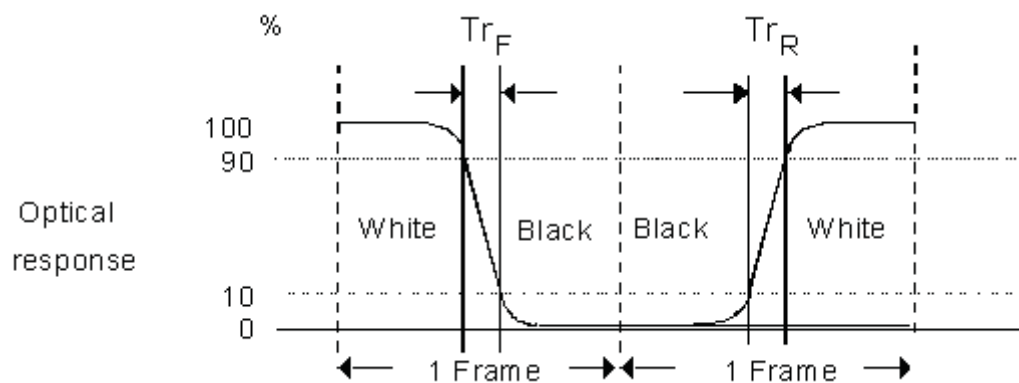



Product Specification

AU OPTRONICS CORPORATION

Note 8. Definition of viewing angle

Viewing angle is the measurement of contrast ratio ≥ 10 , at the screen center, over a 180° horizontal and 180° vertical range (off-normal viewing angles). The 180° viewing angle range is broken down as follows; 90° (θ) horizontal left and right and 90° (ϕ) vertical, high (up) and low (down). The measurement direction is typically perpendicular to the display surface with the screen rotated about its center to develop the desired measurement viewing angle.

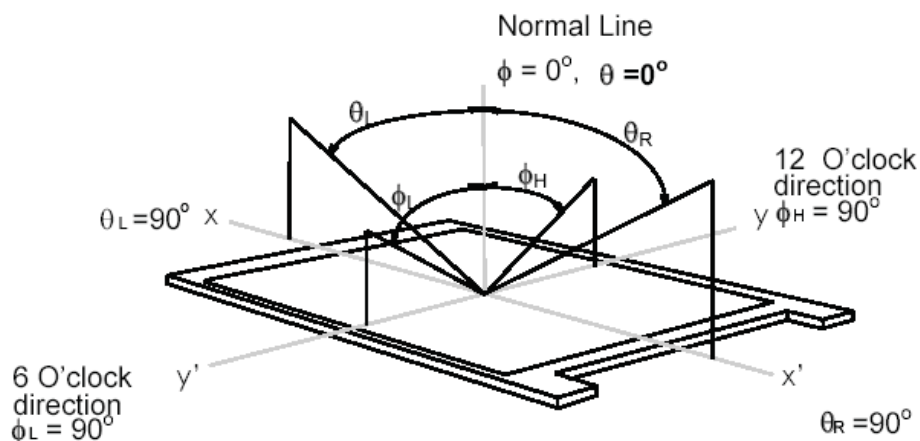

Note 9. (1)Image sticking in white and a black boundary part of the checkers pattern is allowed.

(2)Test pattern and method

2D image sticking

a) Aging

It drives for 24 hours under the environment of 40°C/45%(RH).

The following pattern is displayed at aging.

Aging pattern

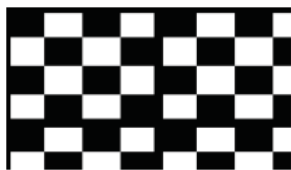

b) Check

Gray (L31) is displayed, and image sticking is confirmed.

3D image sticking

a) Aging

It drives for 48 hours under the environment of 40°C.

The following pattern is displayed at aging.

Aging pattern

Left eye

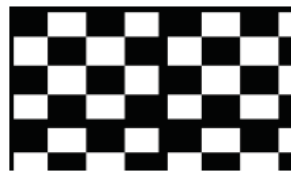

Right eye



White raster(L63)



Product Specification

AU OPTRONICS CORPORATION

3. Functional Block Diagram

The following diagram shows the functional block of the 16 inches wide Color TFT/LCD 30 pin eDP Module

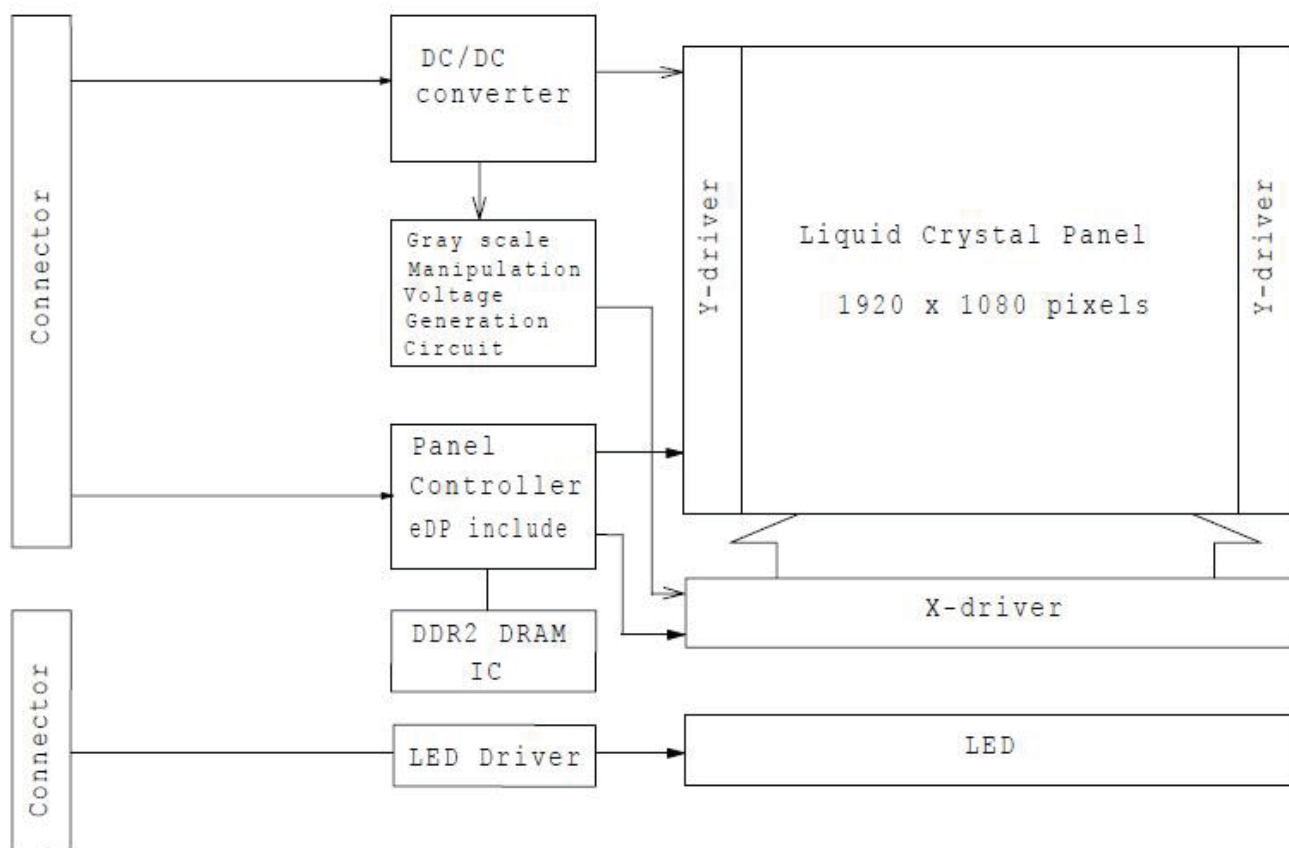



Product Specification

AU OPTRONICS CORPORATION

4. Absolute Maximum Ratings

An absolute maximum rating of the module is as following:

4.1 Absolute Ratings of TFT LCD Module

Item	Symbol	Min	Max	Unit	Conditions
Logic/LCD Drive Voltage	V_{DD33}	-0.3	+4.0	[Volt]	
Logic/LCD Drive Voltage	V_{DD5}	-0.3	+6.5	[Volt]	Note 1,2
Input Voltage of Signals	V_{IN}	-0.3	$V_{DD33}+0.3$	[Volt]	
LED Driver Supply Voltage	V_{LED}	-0.3	22	[Volt]	Note 3
LED Input Current	I_{LED}	0	30	[mA]	Note 3

4.2 Absolute Ratings of Environment

Item	Symbol	Min	Max	Unit	Conditions
Operating Temperature	TOP	0	+50	[°C]	Note 4
Operation Humidity	HOP	10	90	[%RH]	Note 4
Storage Temperature	TST	-20	+60	[°C]	Note 4
Storage Humidity	HST	10	90	[%RH]	Note 4

Note 1: At T_a (25°C)

Note 2: Permanent damage to the device may occur if exceed maximum values

Note 3: LED specification refer to section 5.2

Note 4: For quality performance, please refer to AUO IIS (Incoming Inspection Standard).

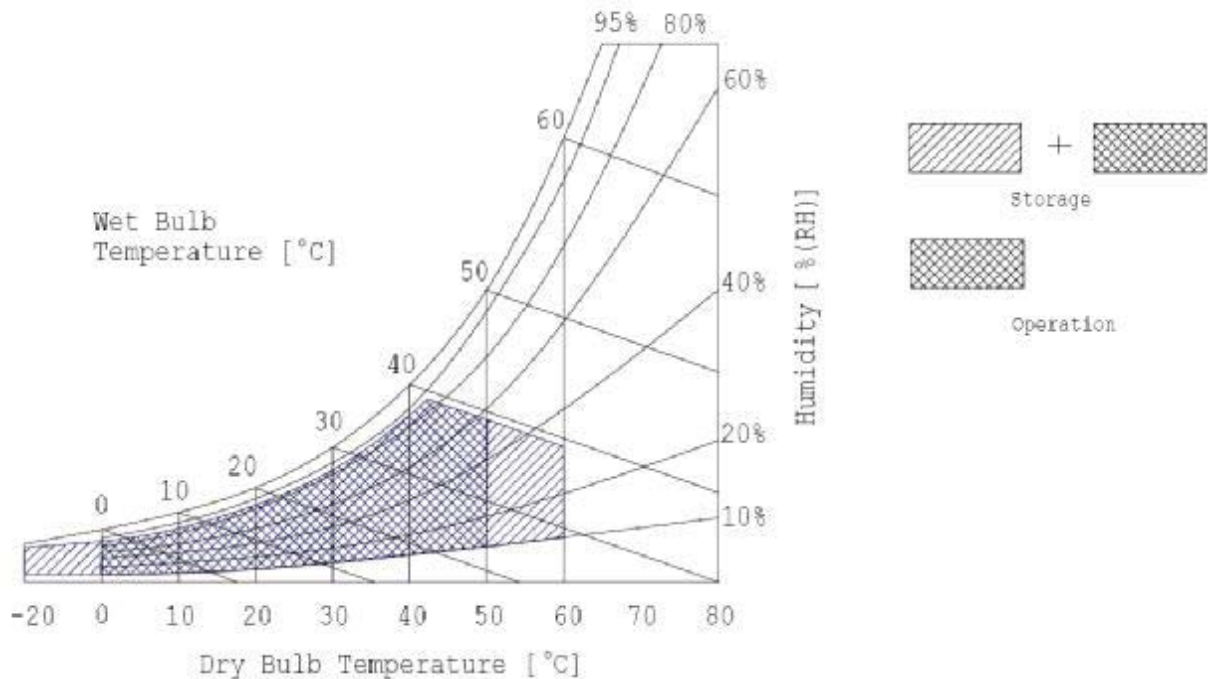



Product Specification

AU OPTRONICS CORPORATION

5. Electrical Characteristics

5.1 TFT LCD Module

5.1.1 Power Specification

Input power specifications are as follows;

The power specification are measured under $25\pm 5^{\circ}\text{C}$ and $65\pm 20\%(\text{RH})$. Timing is typical value.

Symble	Parameter	Min	Typ	Max	Units	Note
VDD33	Logic/LCD Drive Voltage	3.0	3.3	3.6	[Volt]	
VDD5	Logic/LCD Drive Voltage	4.5	5.0	5.5	[Volt]	
I_{DD33}	3.3V 2D still picture Color Bar	-	0.46	0.55	[A]	Note 1
I_{DD33}	3.3V 2D still picture checker	-	0.47	0.56	[A]	Note 1
I_{DD33}	3.3V 2D animation/3D Color Bar	-	0.63	0.76	[A]	Note 1
I_{DD33}	3.3V 2D animation/3D checker	-	0.66	0.79	[A]	Note 1
I_{DD5}	5.0V 2D still picture Color Bar	-	0.65	0.77	[A]	Note 1
I_{DD5}	5.0V 2D still picture checker	-	0.90	1.08	[A]	Note 1
I_{DD5}	5.0V 2D animation/3D Color Bar	-	0.52	0.62	[A]	Note 1
I_{DD5}	5.0V 2D animation/3D checker	-	0.88	1.06	[A]	Note 1

Note 1 : Supply voltage: VDD33=3.3V and VDD5= 5V.

The I_{DD33} and I_{DD5} of Color Bar is measured in the following pattern.

1. White
2. Yellow
3. Purple
4. Red
5. Light Blue
6. Green
7. Blue
8. Black

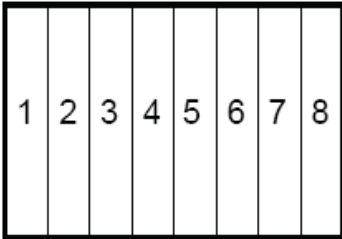

The I_{DD33} and I_{DD5} of Checker is measured in the following pattern.

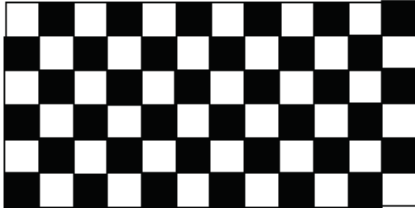



Product Specification

AU OPTRONICS CORPORATION

5.1.2 Signal Electrical Characteristics

Input signals shall be low or High-impedance state when VDD is off.

It is recommended to refer the specifications of VESA Display Port Standard V1.1a in detail.

Signal electrical characteristics are as follows;

Display Port main link signal:

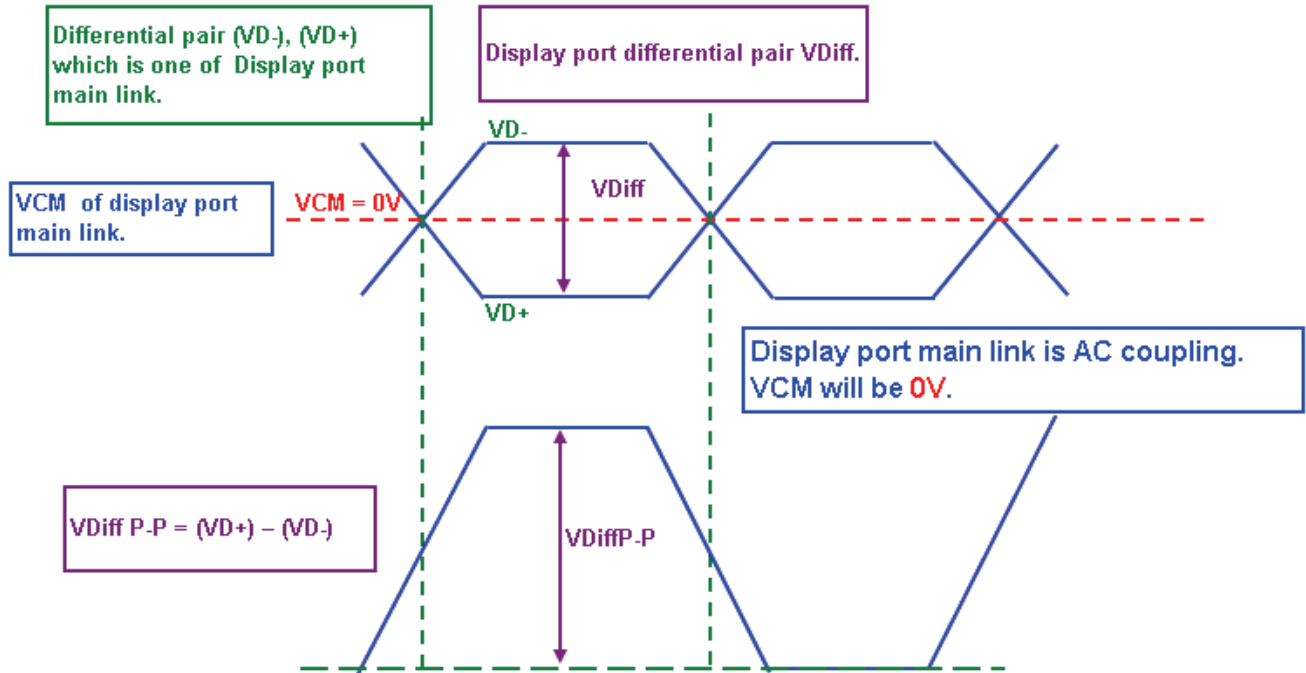

Display Port main link					
		Min	Typ	Max	unit
VCM	Differential common mode voltage	TBD	0	TBD	V
VDiffP-P level1	Differential peak to peak voltage level1	0.34	0.4	0.46	V
VDiffP-P level2	Differential peak to peak voltage level2	0.51	0.6	0.68	V
VDiffP-P level3	Differential peak to peak voltage level3	0.69	0.8	0.92	V
VDiffP-P level4	Differential peak to peak voltage level4	1.02	1.2	1.38	V

Fallow as VESA display port standard V1.1a at both 1.62 and 2.7Gbps link rates.



Product Specification

AU OPTRONICS CORPORATION

Display Port AUX_CH signal:

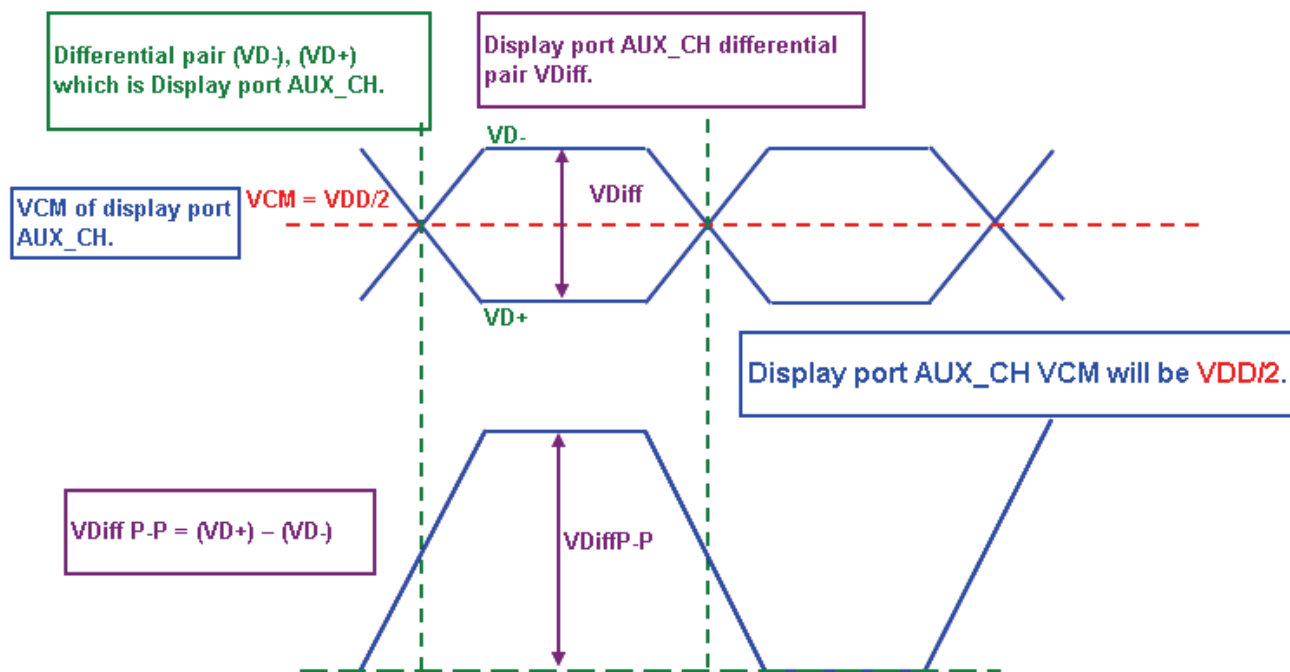

Display Port AUX_CH					
		Min	Typ	Max	unit
VCM	Differential common mode voltage	0	$VDD/2$	2	V
VDiffP-P	Differential peak to peak voltage	0.39		1.38	V

Fallow as VESA display port standard V1.1a.

Display Port VHPD signal:

Display Port VHPD					
		Min	Typ	Max	unit
VHPD	HPD voltage	1.9		2.7	V



Product Specification

AU OPTRONICS CORPORATION

5.2 Backlight Unit

5.2.1 LED characteristics

Parameter	Symbol	Min	Typ ^(Note1)	Max ^(Note2)	Units	Condition
B/L Power 2D still picture	P_{LED2D}	-	10.5	14.4	[Watt]	LED Current 20mA
B/L Power 2D animation / 3D	P_{LED3D}	-	6.9	8.9	[Watt]	LED Current 27mA, Duty 45% Note3
B/L Power Peak 2D animation / 3D	$P_{LED3D\ peak}$	-	15.4	19.8	[Watt]	LED Current 27mA

Note 1: The input voltage range is between 8V and 21V, and Typ. value is a value at the condition that the input voltage is 12 V and ambient temperature is 25 degree C.

Note 2: Max. value is a value at the condition that the input voltage is 8 V and ambient temperature is 0 degree C.

Note 3: B/L Power 2D animation/3D is the average value of power consumption when B/L lights and B/L non-lights in 2D animation/3D mode. B/L Power peak 2D animation/3D is the power consumption when B/L lights in 2D animation/3D mode.



Product Specification

AU OPTRONICS CORPORATION

5.2.2 Backlight input signal characteristics

Parameter	Symbol	Min	Typ	Max	Units	Remark
LED Power Supply	VLED	8.0	-	21.0	[Volt]	
LED B/L Signal Voltage (ON/OFF)	$V_{BL/ON}$	2.1	3.3	3.6	[Volt]	
	$V_{BL/OFF}$	0	-	0.5	[Volt]	
PWM signal Voltage	V_{PWMON}	2.1	3.3	3.6	[Volt]	
	V_{PWMOFF}	0.0	-	0.5	[Volt]	
PWM Input Frequency	FPWM	20	22	24	KHz	The frequency is selected within the range from 10 to 30kHz
PWM Duty Ratio	Duty	12	-	100	%	
Input Signal Voltage	V_{LR}	2.1	3.3	3.6	[Volt]	19pin of interface Connector
Output Signal Voltage	$V_{EMITTER}$	2.1	3.3	3.6	[Volt]	18pin of interface Connector



Product Specification

AU OPTRONICS CORPORATION

6. Signal Interface Characteristic

6.1 Pixel Format Image

Following figure shows the relationship of the input signals and LCD pixel format.

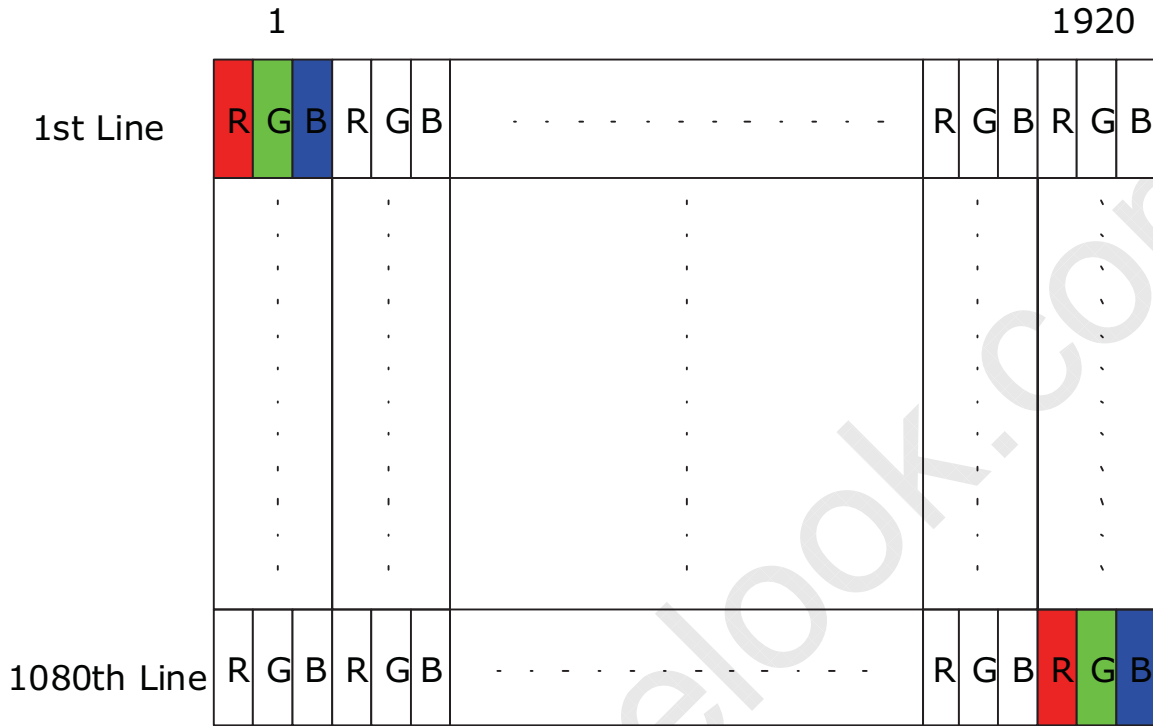



Product Specification

AU OPTRONICS CORPORATION

www.panelook.com



Product Specification

AU OPTRONICS CORPORATION

6.2 Integration Interface Requirement

6.2.1 Connector Description

Physical interface is described as for the connector on module.

These connectors are capable of accommodating the following signals and will be following components.

Connector Name / Designation	For Signal Connector
Manufacturer	I-PEX
Type / Part Number	20455-030E-02 CABLIN-VS 0.5mm Pitch 30pin, DETUM Mark(1pin Mark)

Connector Name / Designation	For LED Connector
Manufacturer	J.S.T Connector
Type / Part Number	SM14B-SHLK-1-TF SHL connector 1.0mm pitch 14pin

6.2.2 Pin Assignment

Signal Connector

PIN#	Signal Name	Description
1	(N.C) HPD	AUX CH-Hot Plug Detect
2	AUX-	AUX CH-
3	AUX+	AUX CH+
4	LANE0+	Main_Link0+
5	LANE0-	Main_Link0-
6	LANE1+	Main_Link1+
7	LANE1-	Main_Link1-
8	LANE2+	Main_Link2+
9	LANE2-	Main_Link2-
10	LANE3+	Main_Link3+
11	LANE3-	Main_Link3-
12	N. C(SCL_1)	N. C(GAMMA correction)
13	N. C(SDA_1)	N. C(GAMMA correction)
14	N. C(GAMMA)	N. C(GAMMA, EDID Write Protect)
15	N. C(SCL_2)	N. C(eDP and other data correction)
16	N. C(SDA_2)	N. C(eDP and other data correction)
17	N. C(WP)	N. C(eDP Write Protect)



Product Specification

AU OPTRONICS CORPORATION

18	EMITTER	EMITTER output
19	L/R	L/R ident input (Right and left identification signal)
20	N. C	
21	VDD3	Logic VDD(3.3V)(DiscreteAWG#32 Use)
22	VDD3	Logic VDD(3.3V)(DiscreteAWG#32 Use)
23	VDD3	Logic VDD(3.3V)(DiscreteAWG#32 Use)
24	VDD5	Logic VDD(5.0V)(DiscreteAWG#32 Use)
25	VDD5	Logic VDD(5.0V)(DiscreteAWG#32 Use)
26	VDD5	Logic VDD(5.0V)(DiscreteAWG#32 Use)
27	GND	GND(DiscreteAWG#32 Use)
28	GND	GND(DiscreteAWG#32 Use)
29	GND	GND(DiscreteAWG#32 Use)
30	GND	GND(DiscreteAWG#32 Use)

Note 1) Please connect GND pin to ground. Don't use it as no-connect nor connection with high impedance.

Note 2) Please connect NC to nothing. Don't connect it to ground to other signal input.

Note 3) The signal from Pin No. 12 to No. 17 is connected with 2.5V power supply through the resistance of 10KΩ.

LED Connector

PIN#	Signal Name	Description
1	VDD B/L	LED Driver VDD(8-21V)(DiscreteAWG#32 Use)
2	VDD B/L	LED Driver VDD(8-21V)(DiscreteAWG#32 Use)
3	VDD B/L	LED Driver VDD(8-21V)(DiscreteAWG#32 Use)
4	VDD B/L	LED Driver VDD(8-21V)(DiscreteAWG#32 Use)
5	LED-GND	LED Driver GND (DiscreteAWG#32 Use)
6	LED-GND	LED Driver GND (DiscreteAWG#32 Use)
7	LED-GND	LED Driver GND (DiscreteAWG#32 Use)
8	LED-GND	LED Driver GND (DiscreteAWG#32 Use)
9	N.C	N.C
10	N.C	N.C
11	N.C	N.C
12	PWM	PWM signal(Brightness control)
13	B/L EN	Backlight ON/OFF
14	N.C	N.C



Product Specification

AU OPTRONICS CORPORATION

6.3 Interface Timing

6.3.1 Timing Characteristics

[2D still]

	Symbol	2D@60Hz 59.9Hz			2D@75Hz 75.0Hz			Unit
		Min.	Typ.	Max.	Min.	Typ.	Max.	
Vertical Term	tv	1130	1144	1560	1204	1224	1245	th
		16.69	16.68	16.68	13.33	13.33	13.33	[ms]
Vertical display term	tvd	1080	1080	1080	1080	1080	1080	th
Vertical blanking term	tvb	50	64	480	124	144	165	th
VSYNC width	tvw	2	6	7	2	6	7	th
Vertical front porch	tvfp	3	3	408	38	42	46	th
Vertical back porch	tvbp	45	55	65	84	96	112	th
Horizontal term	th	2038	2100	2138	3100	3136	3170	tc
		14.77	14.58	10.69	11.07	10.89	10.71	[us]
Horizontal display term	thd	1920	1920	1920	1920	1920	1920	tc
Horizontal blanking term	thb	118	180	218	1180	1216	1250	tc
HSYNC width	thw	70	80	90	70	80	90	tc
Horizontal front porch	thfp	8	40	48	970	976	980	tc
Horizontal back porch	thbp	40	60	80	140	160	180	tc
Clock cycle (Clock frequency)	tc	7.25	6.94	5.00	3.57	3.47	3.38	[ns]
	fclk	138.00	144.00	200.00	280.00	288.00	296.00	[MHz]



Product Specification

AU OPTRONICS CORPORATION

【2D animation】

	Symbol	2D-Film 95.9Hz			2D-PAL 100.0Hz			Unit
		Min.	Typ.	Max.	Min.	Typ.	Max.	
Vertical Term	tv	1290	1300	1310	1142	1152	1162	th
		10.43	10.43	10.43	10.00	10.00	10.00	[ms]
Vertical display term	tvd	1080	1080	1080	1080	1080	1080	th
Vertical blanking term	tvb	210	220	230	62	72	82	th
VSYNC width	tvw	10	12	14	10	12	14	th
Vertical front porch	tvfp	42	48	54	14	20	26	th
Vertical back porch	tvbp	158	160	162	38	40	42	th
Horizontal term	th	2000	2310	2360	2000	2500	2550	tc
		8.08	8.02	7.96	8.76	8.68	8.61	[us]
Horizontal display term	thd	1920	1920	1920	1920	1920	1920	tc
Horizontal blanking term	thb	80	390	440	80	580	630	tc
HSYNC width	thw	20	40	60	20	40	60	tc
Horizontal front porch	thfp	50	330	350	50	520	540	tc
Horizontal back porch	thbp	10	20	30	10	20	30	tc
Clock cycle (Clock frequency)	tc	4.04	3.47	3.37	4.38	3.47	3.37	[ns]
	fclk	247.43	288.00	296.50	228.40	288.00	296.31	[MHz]

	Symbol	2D 110.1Hz			2D-NTSC 119.9Hz			Unit
		Min.	Typ.	Max.	Min.	Typ.	Max.	
Vertical Term	tv	1142	1152	1162	1134	1144	1154	th
		9.08	9.08	9.08	8.34	8.34	8.34	[ms]
Vertical display term	tvd	1080	1080	1080	1080	1080	1080	th
Vertical blanking term	tvb	62	72	82	54	64	74	th
VSYNC width	tvw	10	12	14	10	12	14	th
Vertical front porch	tvfp	20	26	32	18	24	30	th
Vertical back porch	tvbp	32	34	36	26	28	30	th
Horizontal term	th	2000	2270	2320	2000	2100	2140	tc
		7.95	7.88	7.81	7.36	7.29	7.23	[us]
Horizontal display term	thd	1920	1920	1920	1920	1920	1920	tc
Horizontal blanking term	thb	80	350	400	80	180	220	tc
HSYNC width	thw	20	40	60	20	40	60	tc
Horizontal front porch	thfp	50	290	310	50	120	130	tc
Horizontal back porch	thbp	10	20	30	10	20	30	tc
Clock cycle (Clock frequency)	tc	3.98	3.47	3.37	3.68	3.47	3.38	[ns]
	fclk	251.54	288.00	296.90	271.89	288.00	296.05	[MHz]



Product Specification

AU OPTRONICS CORPORATION

[3D]

	Symbol	3D-Film 95.9Hz			3D-PAL 100.0Hz			Unit
		Min.	Typ.	Max.	Min.	Typ.	Max.	
Vertical Term	tv	1290	1300	1310	1142	1152	1162	th
		10.43	10.43	10.43	10.00	10.00	10.00	[ms]
Vertical display term	tvd	1080	1080	1080	1080	1080	1080	th
Vertical blanking term	tvb	210	220	230	62	72	82	th
VSYNC width	tvw	22	24	26	22	24	26	th
Vertical front porch	tvfp	40	46	52	26	32	38	th
Vertical back porch	tvbp	148	150	152	14	16	18	th
Horizontal term	th	2000	2310	2360	2000	2500	2550	tc
		8.08	8.02	7.96	8.76	8.68	8.61	[us]
Horizontal display term	thd	1920	1920	1920	1920	1920	1920	tc
Horizontal blanking term	thb	80	390	440	80	580	630	tc
HSYNC width	thw	20	40	60	20	40	60	tc
Horizontal front porch	thfp	50	330	350	50	520	540	tc
Horizontal back porch	thbp	10	20	30	10	20	30	tc
Clock cycle (Clock frequency)	tc	4.04	3.47	3.37	4.38	3.47	3.37	[ns]
	fcclk	247.43	288.00	296.50	228.40	288.00	296.31	[MHz]

	Symbol	3D 110.1Hz			3D-NTSC 119.9Hz			Unit
		Min.	Typ.	Max.	Min.	Typ.	Max.	
Vertical Term	tv	1142	1152	1162	1134	1144	1154	th
		9.08	9.08	9.08	8.34	8.34	8.34	[ms]
Vertical display term	tvd	1080	1080	1080	1080	1080	1080	th
Vertical blanking term	tvb	62	72	82	54	64	74	th
VSYNC width	tvw	22	24	26	22	24	26	th
Vertical front porch	tvfp	32	38	44	30	36	42	th
Vertical back porch	tvbp	8	10	12	2	4	6	th
Horizontal term	th	2000	2270	2320	2000	2100	2140	tc
		7.95	7.88	7.81	7.36	7.29	7.23	[us]
Horizontal display term	thd	1920	1920	1920	1920	1920	1920	tc
Horizontal blanking term	thb	80	350	400	80	180	220	tc
HSYNC width	thw	20	40	60	20	40	60	tc
Horizontal front porch	thfp	50	290	310	50	120	130	tc
Horizontal back porch	thbp	10	20	30	10	20	30	tc
Clock cycle (Clock frequency)	tc	3.98	3.47	3.37	3.68	3.47	3.38	[ns]
	fcclk	251.54	288.00	296.90	271.89	288.00	296.05	[MHz]

a6.3.2 eDP Specification

Refer to VESA Display port Ver.1.1a.



Product Specification

AU OPTRONICS CORPORATION

6.3.3 Timing diagram

(1) Vertical Timing

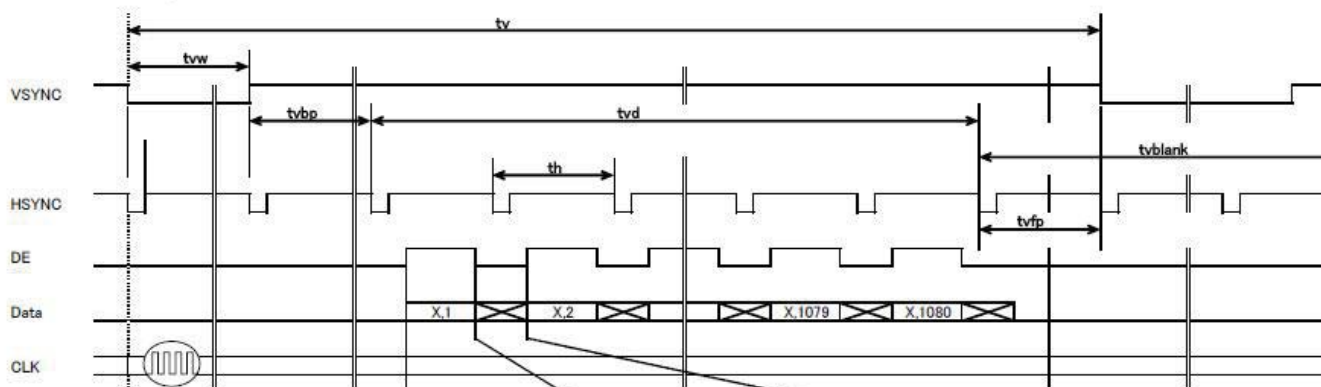

(2) Horizontal Timing

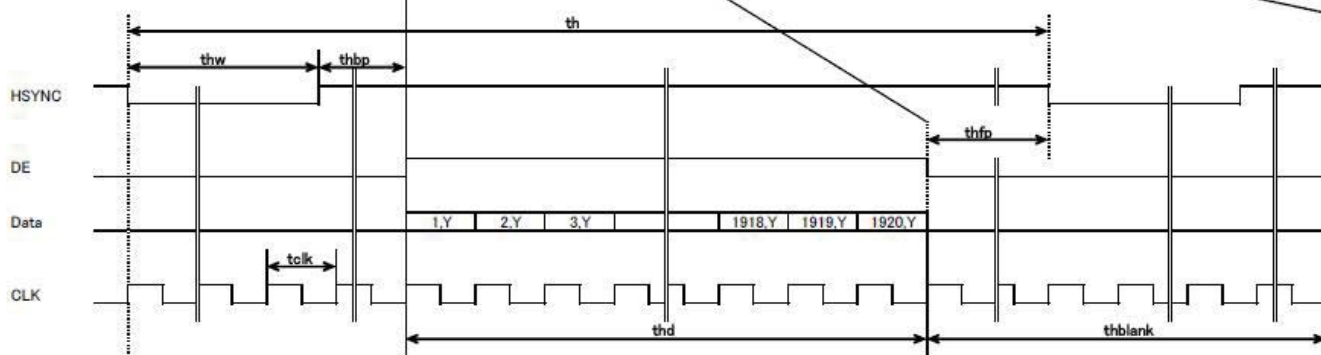



Product Specification

AU OPTRONICS CORPORATION

6.4 Power ON/OFF Sequence

Power on/off sequence is as follows. Interface signals and LED on/off sequence are also shown in the chart.

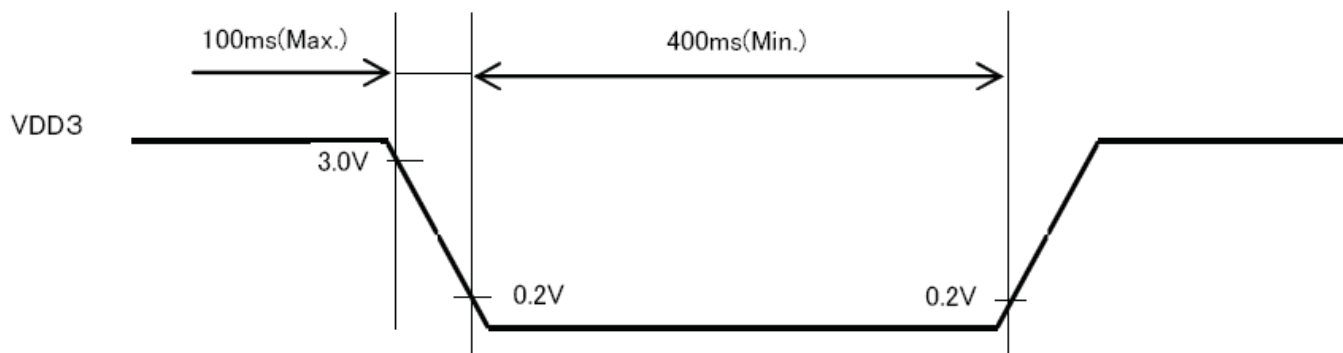

<Case 1>

B/L_EN became H during an initialization period, and when video signal was started, B/L turns it on with about 2 frames after the initialization end.

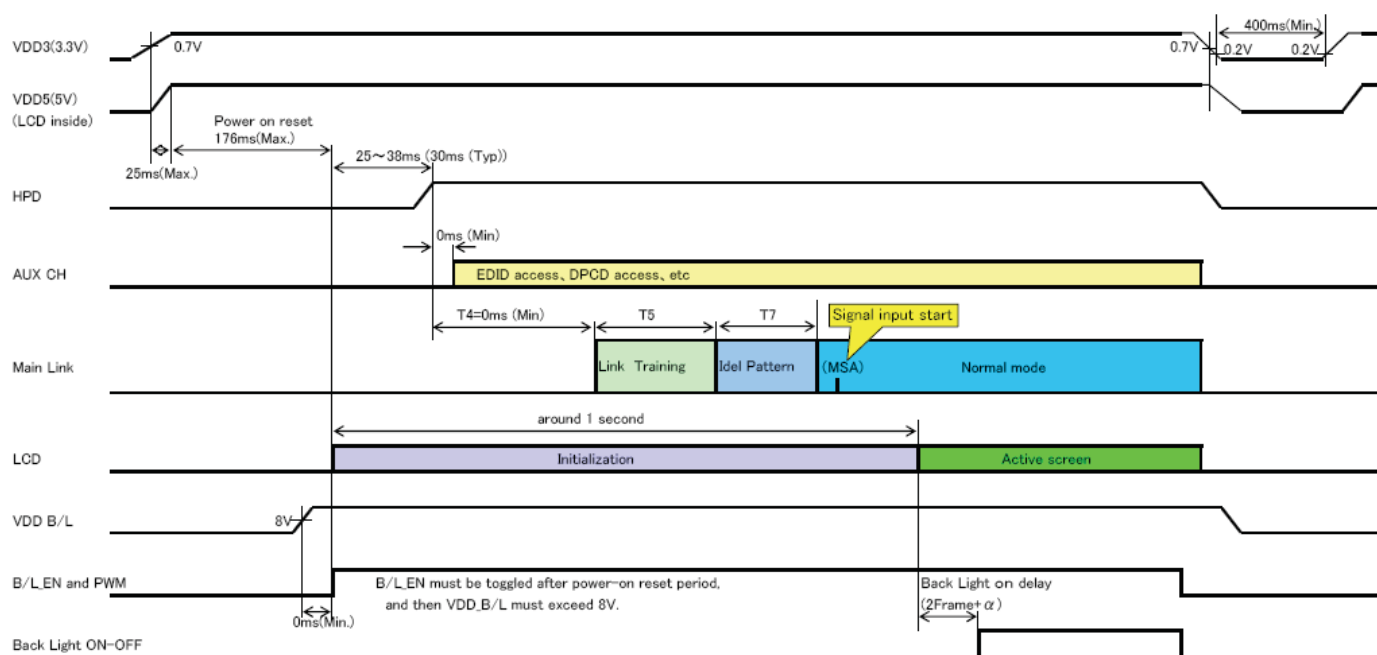



Product Specification

AU OPTRONICS CORPORATION

<Case 2>

Even if B/L_EN becomes H, B/L does not turn on when there is not video signal input.

B/L turns on after about 2 frames after video signal input was started.

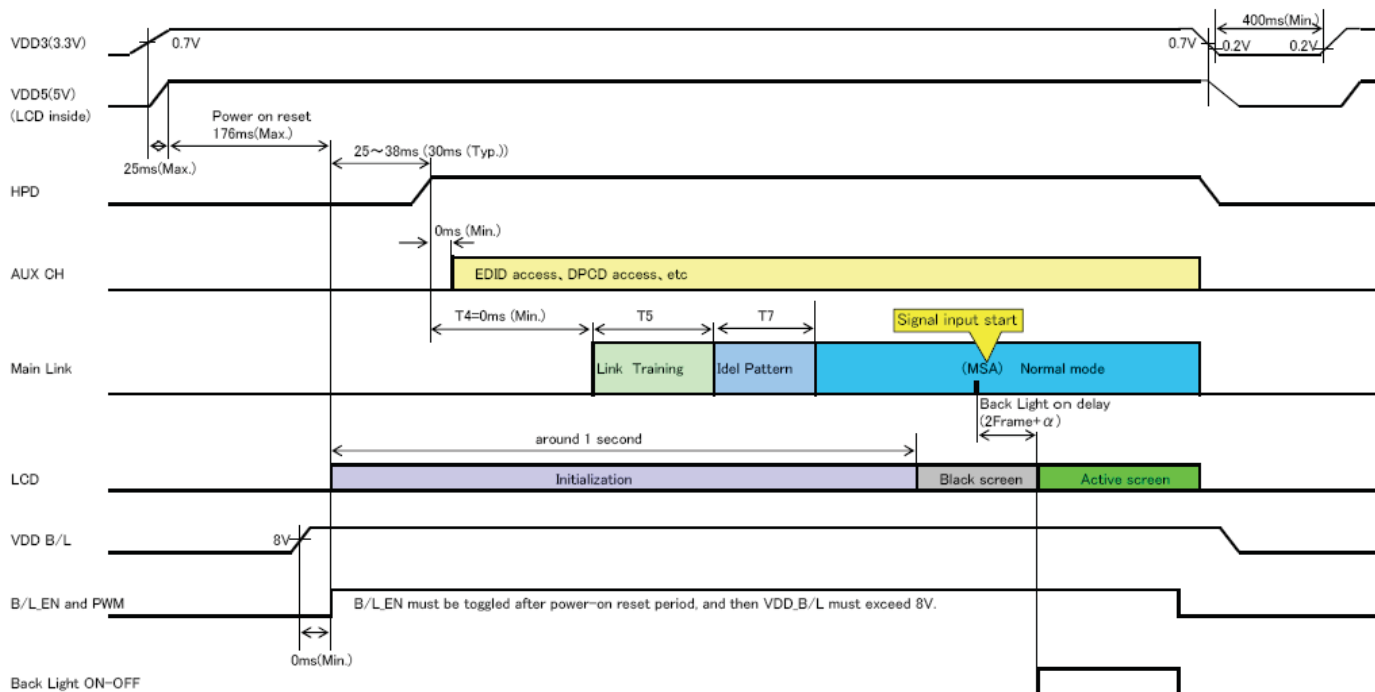

<Case 3>

When B/L_EN toggles in "H" from "L" after an LCD panel became ACTIVE_SCREEN, B/L turns on according to B/L_EN.

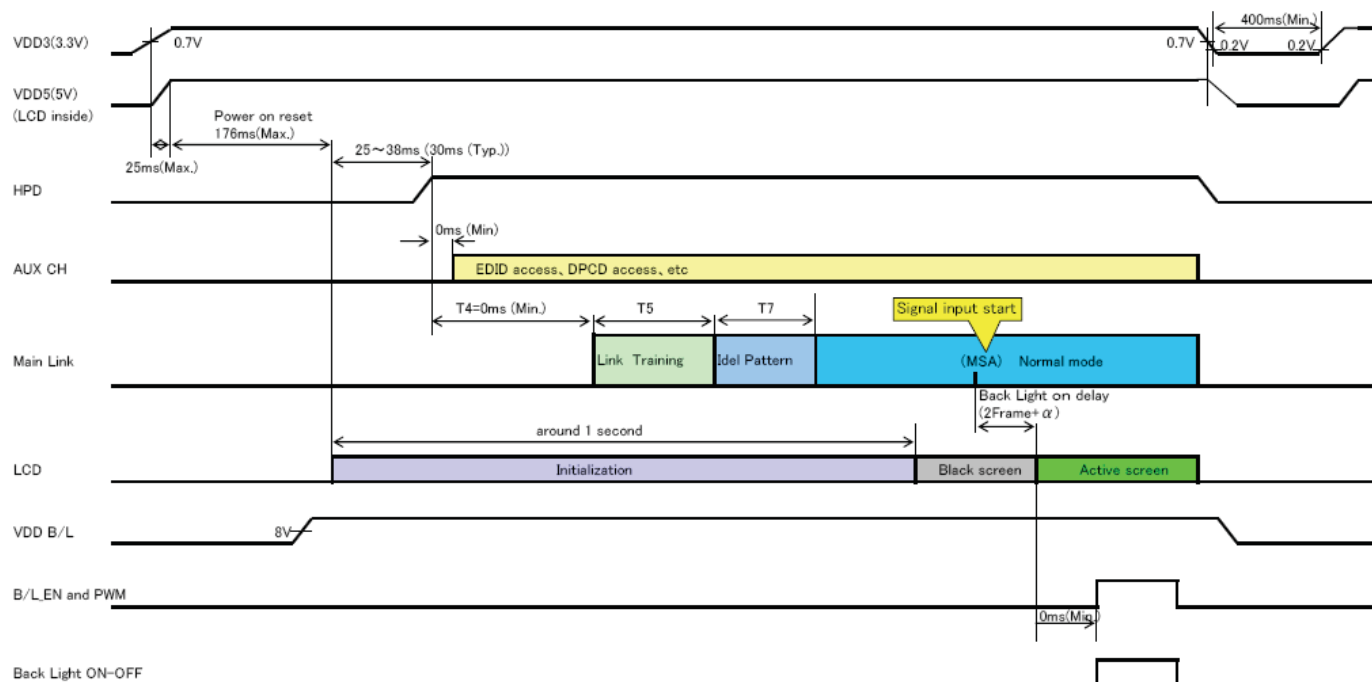



Product Specification

AU OPTRONICS CORPORATION

7. Panel Reliability Test

7.1 Vibration Test

Test Spec:

- Test method: Non-Operation
- Acceleration: 1.5 G
- Frequency: 5 - 500Hz Random
- Sweep: 30 Minutes each Axis (X, Y, Z)

9

7.2 Shock Test

Test Spec:

- Test method: Non-Operation
- Acceleration: 210 G , Half sine wave
- Active time: 3 ms
- Pulse: X,Y,Z .one time for each side

7.3 Reliability Test

Items	Required Condition	Note
High Temperature and High Humidity Operation	Ta= 45°C, 90%RH, 48h	
High Temperature and High Humidity Storage	Ta= 50°C, 90%RH, 48h	
High Temperature Operation	Ta= 50°C, 48h	
Low Temperature Operation	Ta= 0°C, 48h	
High Temperature Storage	Ta= 65°C, 48h	
Low Temperature Storage	Ta= -30°C, 48h	
Thermal Shock Test	Ta=-30°C 2.0h to 65°C 2.0h, 12 cycles	

Definitions of failure for judgment shall be as follows:

- 1) Function of the module should be maintained.
- 2) Current consumption should be smaller than the specified value.
- 3) Appearance and display quality should not have distinguished degradation.
- 4) Luminance should be larger than 50% of the minimum value specified in 2.2.



Product Specification

AU OPTRONICS CORPORATION

8. Mechanical Characteristics

8.1 LCM Outline Dimension

8.1.1 Standard Front View

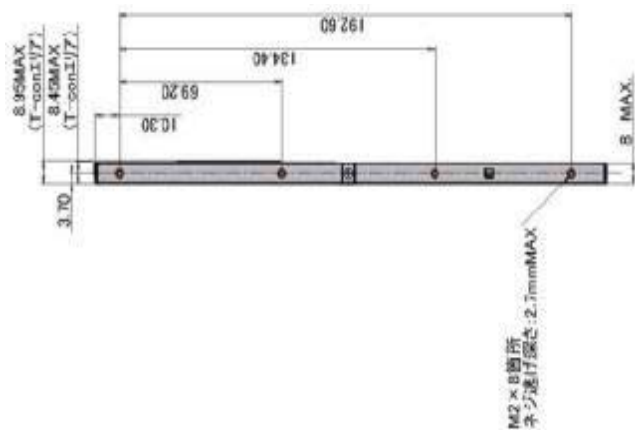

Unit : mm
Standard Tolerance: ±0.5

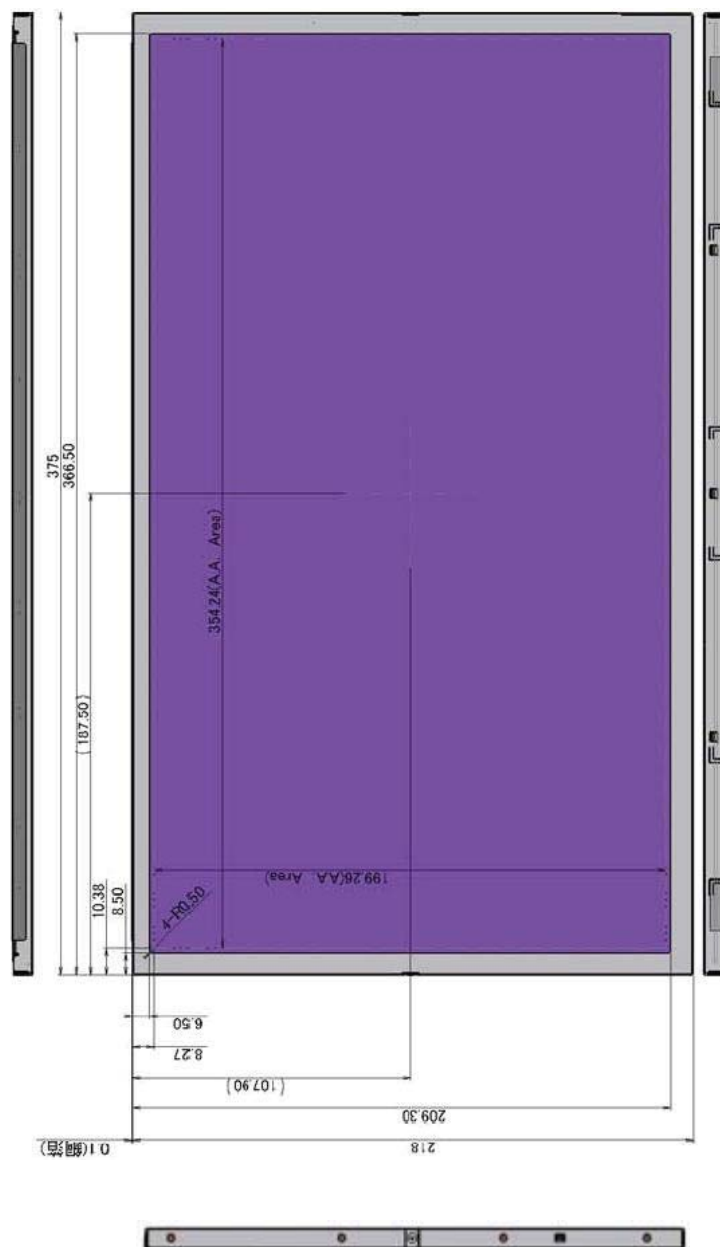



Product Specification

AU OPTRONICS CORPORATION

8.1.2 Standard Rear View

Unit : mm
Standard Tolerance: ±0.5

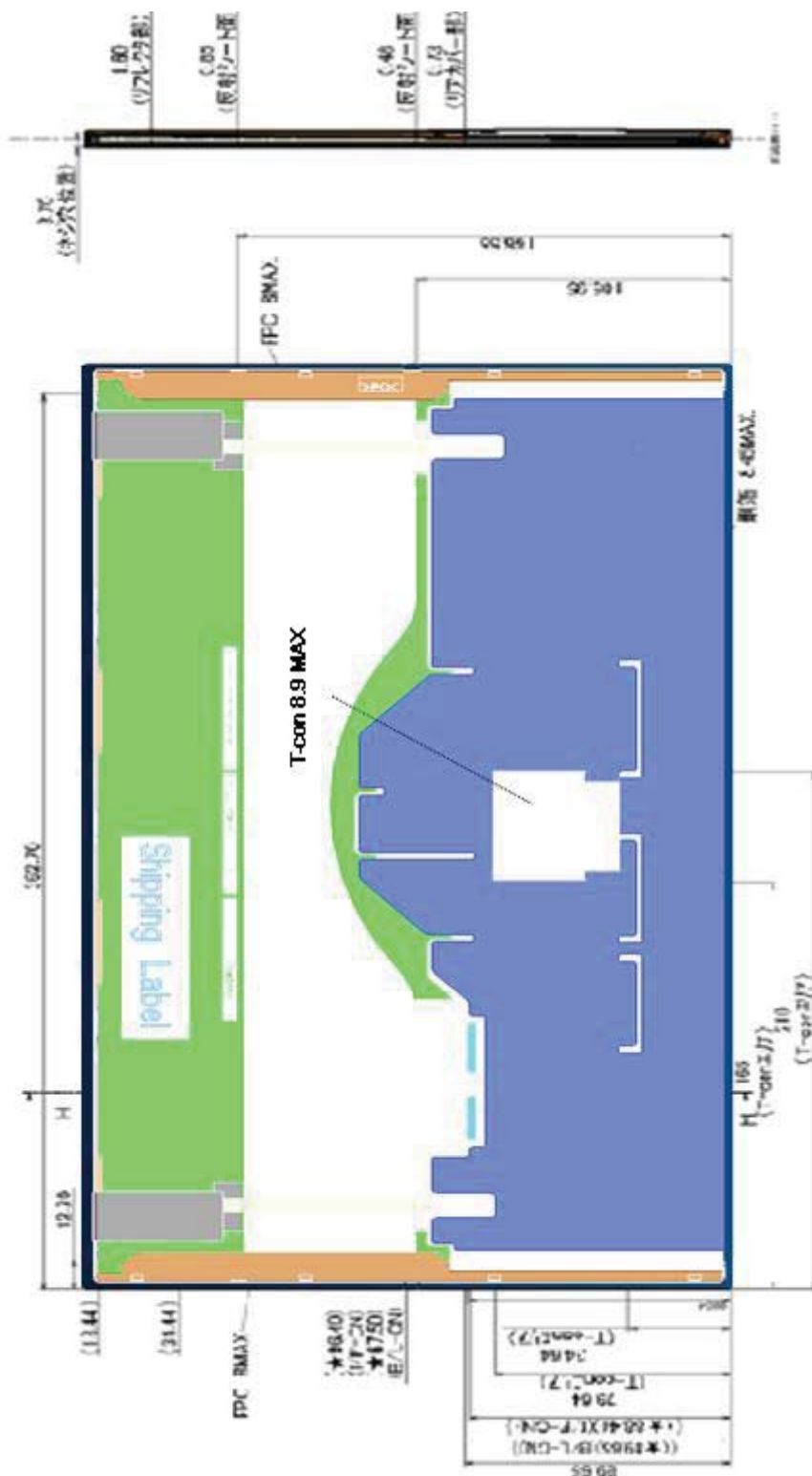

The thickness assumes it the measurement by the 100g load.
 Note) The PCB bend angle, in the front side, is less than 10 degrees, in the back side, is not over the form outline of thickness.
 Note) The hole size tolerance is a material single tolerance. It is not a guaranteed value.



Product Specification

AU OPTRONICS CORPORATION

Warning

<Front>



Note) Never push LCD COF and PCB .

If LCD COF was pressed, It may cause damage of the LCD drive system.

▪ <Rear>

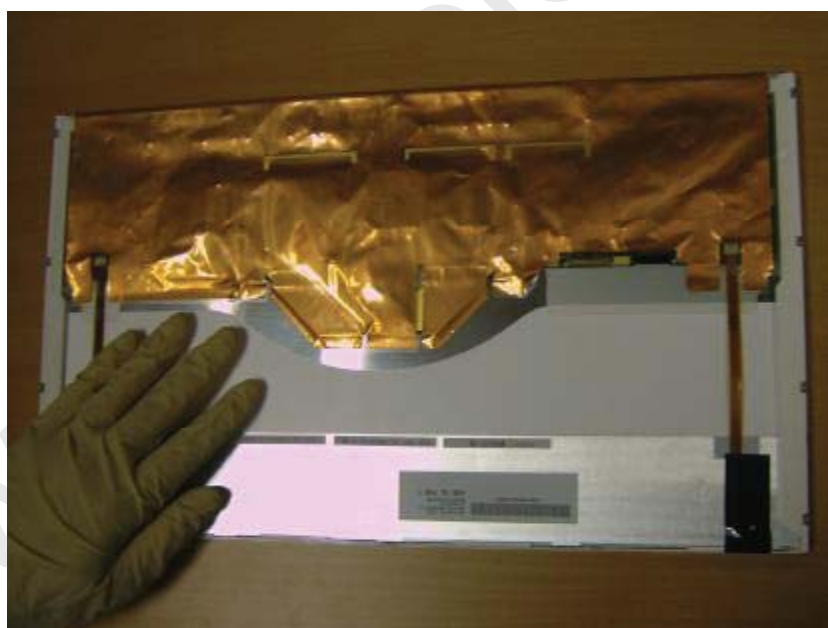

Note) Never push LCD back side.

If LCD back side was pressed, It may cause damage of the back light system.

Note) Never push LCD PCB .

If LCD COF was pressed, It may cause damage of the LCD drive system.



Product Specification

AU OPTRONICS CORPORATION

9. Shipping and Package

9.1 Shipping Label Format



Shipping Label Position



Product Specification

AU OPTRONICS CORPORATION

9.2 Carton Package

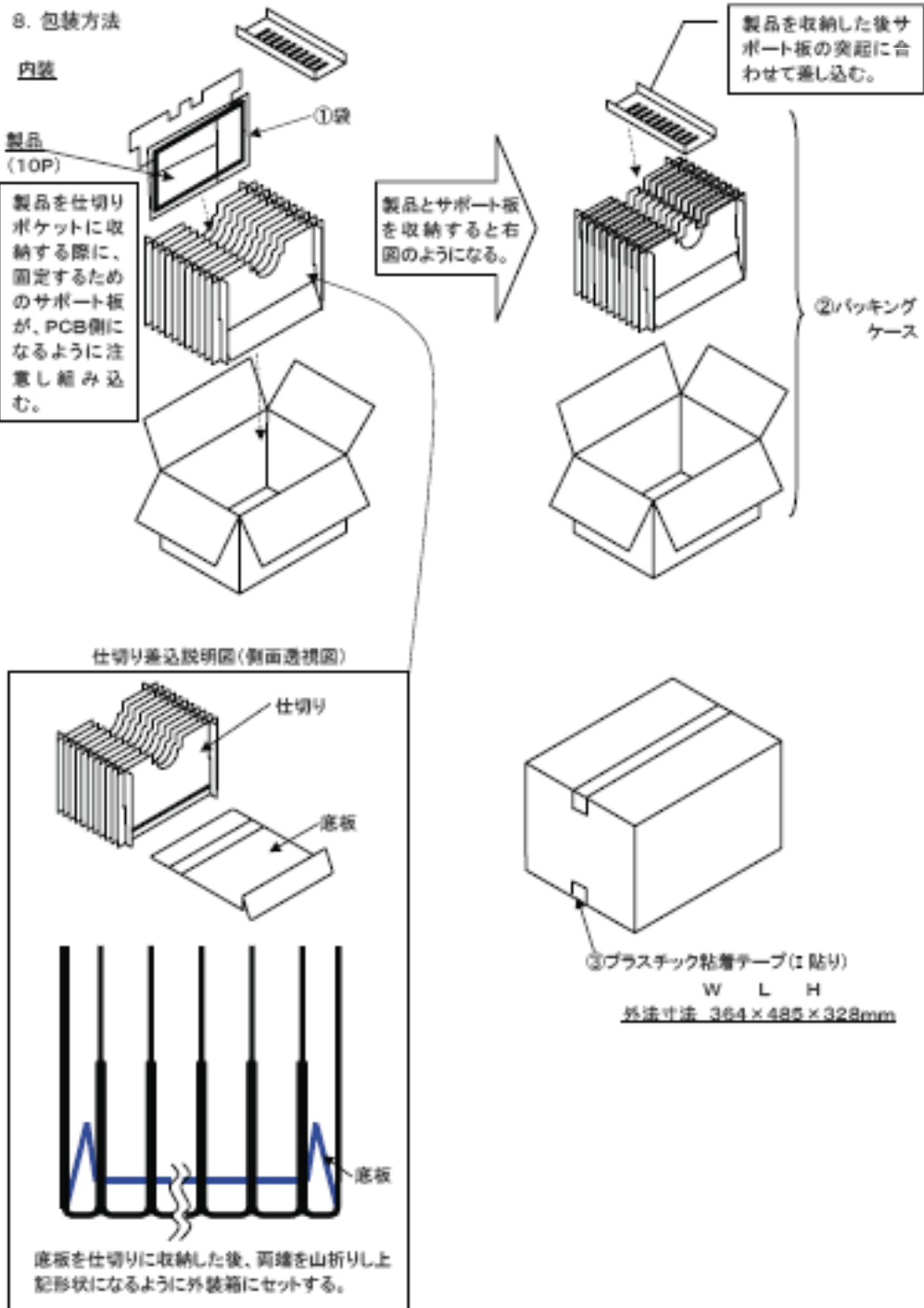



Product Specification

AU OPTRONICS CORPORATION

9.3 Shipping Package of Palletizing Sequence

外装

(注1)端数の場合は、下記の処置を行うこと。

- * 内装の積み段数を減らす。
- * 同じ段内で端数が生じた場合は、空の内装箱を詰め合わせる。

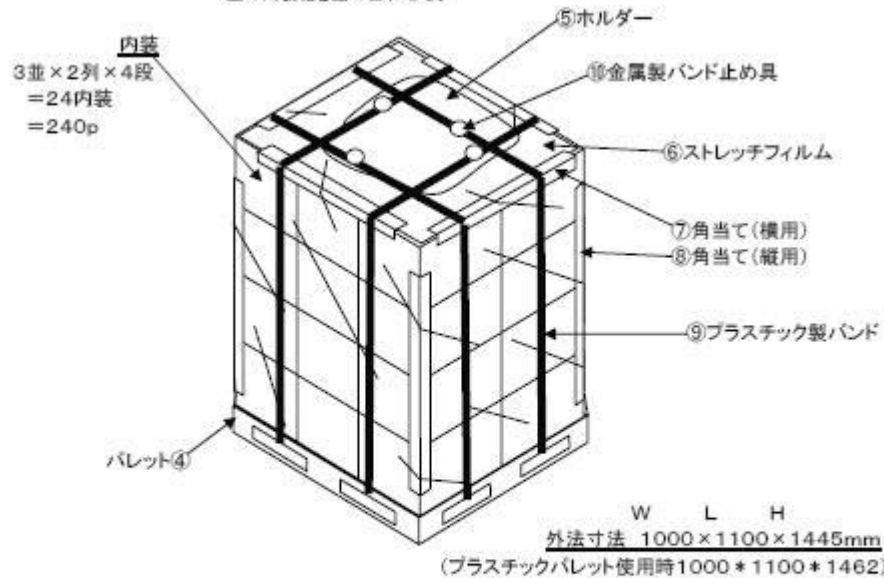

(注2)ストレッチフィルムの巻き方

- (1)巻き始めは粘着面を内側にしてフィルム端を図1の如く固定する。
- (2)巻き時は下側→上側→下側へ行う。
- (3)パレットの引っかかりは、フィルムを50mm以上でローピングする。
- (4)巻き数は下側2、5巻、中間、上側2巻とする。
- (5)巻きテンションはフィルム伸び率で約10%にする。
- (6)天面の引っかかり折り幅は200mm以上とする。
- (7)巻き終わりは、図2の如くフィルム端を固定する。
- (8)フィルムのつなぎはないこと。





Product Specification

AU OPTRONICS CORPORATION

10. Appendix

10.1 EDID Description

Data No.	Data (Hex)	Data (Dec)	説明	実入力	2進数表示	10進数表示
0	00	0	固定入力 (header)			
1	FF	255				
2	FF	255				
3	FF	255				
4	FF	255				
5	FF	255				
6	FF	255				
7	00	0				
8	06	6	メーカー (ASCIIコードで入力)			
9	AF	175				
10	08	8	ブランクID (10, 11番地は逆転して使用される)	0908		
11	09	9				
12	01	1	シリアルNo. 未記入の場合は『01』入力	未記入		
13	01	1				
14	01	1				
15	01	1				
16	10	16	製造週 (-53週 閏年は54週)	16週		16
17	14	20	製造年 (製造年-1990)	2010年		20
18	01	1	EDID Version \$structure ①-②) ①:18番地 ②:19番地	1.4		1
19	04	4				4
20	95	149	Video Input 情報		10010101	
21	23	35	画面サイズ (m) (21番地:横 22番地:縦)	16inch		35
22	14	20		35cm/20cm		20
23	78	120	階調γ値 (γ値×100-100)	γ = 2.2		120
24	02	2	色度情報		00000010	
25	10	16	色度 R,G,B,W 10進数を2進数(10桁)に変換。 その際、誤差は±0.0005以下とする。 (例:0.610→1001110001) (0.6108516)		00010000	
26	65	101			01100101	
27	A7	167		Rx=0.652	10100111	
28	56	86		Ry=0.337	01010110	
29	49	73		Gx=0.285	01001001	
30	A8	168		Gy=0.656	10101000	
31	28	40		Bx=0.157	00101000	
32	A	10		By=0.041	00001010	
33	50	80		Wx=0.313	01010000	
34	54	84		Wy=0.329	01010100	
35	00	0	Establish Timing 受像可能な解像度には全てbitを立てる。 LCDは60Hzのみbitを立てるのが良い。	該当無し	00000000	
36	00	0			00000000	
37	00	0			00000000	



Product Specification

AU OPTRONICS CORPORATION

38	D1	209	Standard Timing ・受像可能な代表的な全ての解像度を記入。 ・2Byteのコードで1つの解像度を表示。 ・計8種類の解像度を記述出来る。 ・E-Timing(35-37番地)と重複しない事。 ・E-TimingとS-Timingのどちらかに最大解像度を記述する。 ・未使用部分には 01 01 を入れる。 #1: (水平解像度/8) - 31 → 16進数 #2: 7-6Bit...アスペクト比 16:10 → 0,0 4:3 → 0,1 5:4 → 1,0 16:9 → 1,1 5-0Bit...リフレッシュレート - 60	1920		209	
39	C0	192			16.9 60Hz	11000000	
40	01	1					
41	01	1					
42	01	1					
43	01	1					
44	01	1					
45	01	1					
46	01	1					
47	01	1					
48	01	1					
49	01	1					
50	01	1					
51	01	1					
52	01	1					
53	01	1					
54	80	128	Preferred Timing (24番地のフラグを立てておく) 1920x1080, 75Hz, 2D				
55	70	112	54,55番地:ピクセルクロック/10000	288MHz		28800	
56	80	128	56番地:水平表示期間(pixels)/下位8bit(全12bit)	1920Pixels	10000000	1920	
57	C0	192	57番地:水平ブランキング(pixels)/下位8bit(全12bit)	1216Pixels	11000000	1216	
58	74	116	58番地:H-A上位4bit + H-B上位4bit		01110100		
59	38	56	59番地:垂直表示期間(lines)/下位8bit(全12bit)	1080Lines	00111000	1080	
60	90	144	60番地:垂直ブランキング(lines)/下位8bit(全12bit)	144Lines	10010000	144	
61	40	64	61番地:V-A上位4bit + V-B上位4bit		01000000		
62	D0	208	62番地:H-Sync. Offset(フロントポーチ)/下位8bit(全10bit)	976Pixels	11010000	976	
63	50	80	63番地:H-Sync.(パルス幅)/下位8bit(全10bit)	80Pixels	01010000	80	
64	A6	166	64番地:V-フロントポーチ下位4bit + V-Sync.下位4bit (全6bit)	42/6Lines	10100110		
65	C8	200	65番地:コメント参照		11001000		
66	63	99	66番地:画面サイズ横(mm)/下位8bit(全12bit)	355mm	01100011	355	
67	C8	200	66番地:画面サイズ縦(mm)/下位8bit(全12bit)	200mm	11001000	200	
68	10	16	68番地:画面サイズ上位4bit + 画面サイズ縦上位4bit		00010000		
69	00	0	69番地:H-Border(全8bit)	0Pixels	00000000	0	
70	00	0	70番地:V-Border(全8bit)	0Lines	00000000	0	
71	18	24	71番地:フラグ(E-EDID Standard Page 18 of 32参照)		00011000		
72	80	128	Detailed Timing 1920x1080, 120(119.88)Hz, 3D				
73	70	112	72,73番地:ピクセルクロック/10000	288MHz		28800	
74	80	128	74番地:水平表示期間(pixels)/下位8bit(全12bit)	1920Pixels	10000000	1920	
75	B4	180	75番地:水平ブランキング(pixels)/下位8bit(全12bit)	180Pixels	10110100	180	
76	70	112	76番地:H-A上位4bit + H-B上位4bit		01110000		
77	38	56	77番地:垂直表示期間(lines)/下位8bit(全12bit)	1080lines	00111000	1080	
78	40	64	78番地:垂直ブランキング(lines)/下位8bit(全12bit)	64lines	01000000	64	
79	40	64	79番地:V-A上位4bit + V-B上位4bit		01000000		
80	78	120	80番地:H-Sync. Offset(フロントポーチ)/下位8bit(全10bit)	120Pixels	01111000	120	
81	28	40	81番地:H-Sync.(パルス幅)/下位8bit(全10bit)	40Pixels	00101000	40	
82	8C	140	82番地:V-フロントポーチ下位4bit + V-Sync.下位4bit (全6bit)	24/12Lines	10001100		
83	04	4	83番地:コメント参照		00000100		
84	63	99	84番地:画面サイズ横(mm)/下位8bit(全12bit)	355mm	01100011	355	
85	C8	200	85番地:画面サイズ縦(mm)/下位8bit(全12bit)	200mm	11001000	200	
86	10	16	86番地:画面サイズ上位4bit + 画面サイズ縦上位4bit		00010000		
87	00	0	87番地:H-Border(全8bit)	0Pixels	00000000	0	
88	00	0	88番地:V-Border(全8bit)	0Lines	00000000	0	
89	18	24	89番地:フラグ(E-EDID Standard Page 18 of 32参照)		00011000		



Product Specification

AU OPTRONICS CORPORATION

90	80	128	Detailedタイミング		
91	70	112	1920x1080, 100Hz, 3D	288MHz	28800
92	80	128	*番地: 水平表示期間 (pixels) / 下位8bit (全12bit)	1920Pixels	10000000 1920
93	44	68	*番地: 水平フランク (pixels) / 下位8bit (全12bit)	580Pixels	01000100 580
94	72	114	*番地: H-A上位4bit + H-B上位4bit		01110010
95	38	56	*番地: 垂直表示期間 (lines) / 下位8bit (全12bit)	1080Lines	00111000 1080
96	48	72	*番地: 垂直フランク (lines) / 下位8bit (全12bit)	72Lines	01001000 72
97	40	64	*番地: V-A上位4bit + V-B上位4bit		01000000
98	08	8	*番地: H-Sync. Offset (フロントホーチ) / 下位8bit (全10bit)	520Pixels	00001000 520
99	28	40	*番地: H-Sync. (ハルス幅) / 下位8bit (全10bit)	40Pixels	00101000 40
100	40	76	*番地: V-フロントホーチ下位4bit + V-Sync. 下位4bit (全6bit)	20/12Lines	01001100
101	84	132	*番地: コマ参照		10000100
102	63	99	*番地: 画面サイズ横 (mm) / 下位8bit (全12bit)	355mm	01100011 355
103	08	200	*番地: 画面サイズ縦 (mm) / 下位8bit (全12bit)	200mm	11001000 200
104	10	16	*番地: 画面サイズ上位4bit + 画面サイズ縦上位4bit		00010000
105	00	0	*番地: H-Border (全8bit)	0Pixels	00000000 0
106	00	0	*番地: V-Border (全8bit)	0Lines	00000000 0
107	18	24	*番地: フラグ (E-EDID Standard Page 18 of 32参照)		00011000
108	00	0	モデル名 (識別 FC)		
109	00	0			
110	00	0	Header: 00 00 00 FC 00		
111	FE	254	モデル名: ASCIIコードにて記述		
112	00	0	Terminator: 0A		
113	42	66	Blank: 20	B	B
114	31	49		1	1
115	36	54		6	6
116	30	48		0	0
117	48	72		H	H
118	57	87		W	W
119	30	48		0	0
120	32	50		2	2
121	20	32			
122	56	86		V	V
123	30	48		0	0
124	30	48		0	0
125	41	65		A	A
126	01	1	Extension Flag (Extensionが無い場合は"00"と記入)		
127	70	112	Check-Sum (0-127番地を合計し下2桁が00になる値)		
128	02	2	EXTENSION Block Tag Code CEA 861の場合は02	2	
129	03	3	CEA 861 EXTENSION Block Version #3	3	
130	04	4	Detail Timing Descriptors start at address	4	
131	01	1	total number of native formats	1	
132	80	128	Detailedタイミング		
133	70	112	1920x1080, 96(95.904)Hz, 3D	288MHz	28800
134	80	128	*番地: 水平表示期間 (pixels) / 下位8bit (全12bit)	1920Pixels	10000000 1920
135	86	134	*番地: 水平フランク (pixels) / 下位8bit (全12bit)	390Pixels	10000110 390
136	71	113	*番地: H-A上位4bit + H-B上位4bit		01110001
137	38	56	*番地: 垂直表示期間 (lines) / 下位8bit (全12bit)	1080Lines	00111000 1080
138	DC	220	*番地: 垂直フランク (lines) / 下位8bit (全12bit)	220Lines	11011100 220
139	40	64	*番地: V-A上位4bit + V-B上位4bit		01000000
140	4A	74	*番地: H-Sync. Offset (フロントホーチ) / 下位8bit (全10bit)	330Pixels	01001010 330



Product Specification

AU OPTRONICS CORPORATION

141	28	40	*番地:H-Sync.(ハルス幅)/下位8bit(全10bit)	40Pixels	00101000	40
142	0C	12	*番地:V-フロントホーチ下位4bit + V-Sync.下位4bit (全6bit)	48/12Lines	00001100	
143	4C	76	*番地:コメント参照		01001100	
144	63	99	*番地:画面サイズ横(mm)/下位8bit(全12bit)	355mm	01100011	355
145	C8	200	*番地:画面サイズ縦(mm)/下位8bit(全12bit)	200mm	11001000	200
146	10	16	*番地:画面サイズ上位4bit + 画面サイズ縦上位4bit		00010000	
147	00	0	*番地:H-Border(全8bit)	0Pixels	00000000	0
148	00	0	*番地:V-Border(全8bit)	0Lines	00000000	0
149	18	24	*番地:フラグ(E-EDID Standard Page 18 of 32参照)		00011000	
150	40	64	Detailedタイミグ			
151	38	56	1920x1080, 60(59.94)Hz, 2D	144MHz		14400
152	80	128	*番地:水平表示期間(pixels)/下位8bit(全12bit)	1920Pixels	10000000	1920
153	B4	180	*番地:水平ブランキング(pixels)/下位8bit(全12bit)	180Pixels	10110100	180
154	70	112	*番地:H-A上位4bit + H-B上位4bit		01110000	
155	38	56	*番地:垂直表示期間(lines)/下位8bit(全12bit)	1080lines	00111000	1080
156	40	64	*番地:垂直ブランキング(lines)/下位8bit(全12bit)	64lines	01000000	64
157	40	64	*番地:V-A上位4bit + V-B上位4bit		01000000	
158	28	40	*番地:H-Sync. Offset(フロントホーチ)/下位8bit(全10bit)	40Pixels	00101000	40
159	50	80	*番地:H-Sync.(ハルス幅)/下位8bit(全10bit)	80Pixels	01010000	80
160	36	54	*番地:V-フロントホーチ下位4bit + V-Sync.下位4bit (全6bit)	3/6Lines	00110110	
161	00	0	*番地:コメント参照		00000000	
162	63	99	*番地:画面サイズ横(mm)/下位8bit(全12bit)	355mm	01100011	355
163	C8	200	*番地:画面サイズ縦(mm)/下位8bit(全12bit)	200mm	11001000	200
164	10	16	*番地:画面サイズ上位4bit + 画面サイズ縦上位4bit		00010000	
165	00	0	*番地:H-Border(全8bit)	0Pixels	00000000	0
166	00	0	*番地:V-Border(全8bit)	0Lines	00000000	0
167	18	24	*番地:フラグ(E-EDID Standard Page 18 of 32参照)		00011000	
168	00	0	以下 check sumまで null			
169	00	0				
170	00	0				
171	00	0				
172	00	0				
173	00	0				
174	00	0				
175	00	0				
176	00	0				
177	00	0				
178	00	0				
179	00	0				
180	00	0				
181	00	0				
182	00	0				
183	00	0				
184	00	0				
185	00	0				
186	00	0				
187	00	0				
188	00	0				
189	00	0				
190	00	0				



Product Specification

AU OPTRONICS CORPORATION

191	00	0			
192	00	0			
193	00	0			
194	00	0			
195	00	0			
196	00	0			
197	00	0			
198	00	0			
199	00	0			
200	00	0			
201	00	0			
202	00	0			
203	00	0			
204	00	0			
205	00	0			
206	00	0			
207	00	0			
208	00	0			
209	00	0			
210	00	0			
211	00	0			
212	00	0			
213	00	0			
214	00	0			
215	00	0			
216	00	0			
217	00	0			
218	00	0			
219	00	0			
220	00	0			
221	00	0			
222	00	0			
223	00	0			
224	00	0			
225	00	0			
226	00	0			
227	00	0			
228	00	0			
229	00	0			
230	00	0			
231	00	0			
232	00	0			
233	00	0			
234	00	0			
235	00	0			
236	00	0			
237	00	0			
238	00	0			
239	00	0			
240	00	0			



Product Specification

AU OPTRONICS CORPORATION

241	00	0				
242	00	0				
243	00	0				
244	00	0				
245	00	0				
246	00	0				
247	00	0				
248	00	0				
249	00	0				
250	00	0				
251	00	0				
252	00	0				
253	00	0				
254	00	0				
255	49	73	Check-Sum (128-255番地を合計し下2桁が00になる値)			

www.panelook.com