



Product Specification

AU OPTRONICS CORPORATION

() Preliminary Specifications

(V) Final Specifications

Module	17.0" WUXGA Color TFT-LCD
Model Name	B170UW01 V2 (HW 1A)

Customer	Date	Approved by	Date
		<u>Beyond Yang</u>	<u>09/03/2008</u>
Checked & Approved by	Date	Prepared by	Date
_____	_____	<u>Claire Yu</u>	<u>09/03/2008</u>
Note: This Specification is subject to change without notice.		NBBU Marketing Division / AU Optronics corporation	



Product Specification

AU OPTRONICS CORPORATION

Contents

1. Handling Precautions	4
2. General Description	5
2.1 General Specification	5
2.2 Optical Characteristics	6
3. Functional Block Diagram	11
4. Absolute Maximum Ratings	12
4.1 Absolute Ratings of TFT LCD Module	12
4.2 Absolute Ratings of Backlight Unit	12
4.3 Absolute Ratings of Environment	12
5. Electrical characteristics	13
5.1 TFT LCD Module	13
5.2 Backlight Unit	15
6. Signal Characteristic	17
6.1 Pixel Format Image	17
6.2 The input data format	18
6.3 Signal Description/Pin Assignment	19
6.4 Interface Timing	21
7. Connector Description	24
7.1 TFT LCD Module	24
7.2 Backlight Unit	24
7.3 Signal for Lamp connector	24
8. Dynamic Test	25
8.1 Vibration Test	25
8.2 Shock Test Spec:	25
9. Reliability	26
10. Mechanical Characteristics	27
10.1 LCM Outline Dimension	27
10.2 Screw Hole Depth and Center Position	29
11. Shipping and Package	30
11.1 Shipping Label Format	30
11.2 Carton package	31
11.3 Shipping package of palletizing sequence	31
12. Appendix: EDID description	32



Product Specification

AU OPTRONICS CORPORATION

1. Handling Precautions

- 1) Since front polarizer is easily damaged, pay attention not to scratch it.
- 2) Be sure to turn off power supply when inserting or disconnecting from input connector.
- 3) Wipe off water drop immediately. Long contact with water may cause discoloration or spots.
- 4) When the panel surface is soiled, wipe it with absorbent cotton or other soft cloth.
- 5) Since the panel is made of glass, it may break or crack if dropped or bumped on hard surface.
- 6) Since CMOS LSI is used in this module, take care of static electricity and insure human earth when handling.
- 7) Do not open nor modify the Module Assembly.
- 8) Do not press the reflector sheet at the back of the module to any directions.
- 9) In case if a Module has to be put back into the packing container slot after once it was taken out from the container, do not press the center of the CCFL Reflector edge. Instead, press at the far ends of the CCFL Reflector edge softly. Otherwise the TFT Module may be damaged.
- 10) At the insertion or removal of the Signal Interface Connector, be sure not to rotate nor tilt the Interface Connector of the TFT Module.
- 11) After installation of the TFT Module into an enclosure (Notebook PC Bezel, for example), do not twist nor bend the TFT Module even momentary. At designing the enclosure, it should be taken into consideration that no bending/twisting forces are applied to the TFT Module from outside. Otherwise the TFT Module may be damaged.
- 12) Cold cathode fluorescent lamp (CCFL) in LCD contains a small amount of mercury. Please follow local ordinances or regulations for disposal.
- 13) Small amount of materials having no flammability grade is used in the LCD module. The LCD module should be supplied by power complied with requirements of Limited Power Source (IEC60950 or UL1950), or be applied exemption.
- 14) The LCD module is designed so that the CCFL in it is supplied by Limited Current Circuit (IEC60950 or UL1950). Do not connect the CCFL in Hazardous Voltage Circuit.



Product Specification

AU OPTRONICS CORPORATION

2. General Description

B170UW01 V0 is a Color Active Matrix Liquid Crystal Display composed of a TFT LCD panel, a driver circuit, and backlight system. The screen format is intended to support the WUXGA (1920(H) x 1200(V)) screen and 262k colors (RGB 6-bits data driver) without backlight inverter. All input signals are LVDS interface compatible.

B170UW01 V0 is designed for a display unit of notebook style personal computer and industrial machine.

2.1 General Specification

The following items are characteristics summary on the table at 25 °C condition:

Items	Unit	Specifications			
Screen Diagonal	[mm]	433 (17"W)			
Active Area	[mm]	367.2 X 229.5			
Pixels H x V		1920x3(RGB) x 1200			
Pixel Pitch	[mm]	0.1912X0.1912			
Pixel Format		R.G.B. Vertical Stripe			
Display Mode		Normally White			
White Luminance (I _{CCFL} =6.0mA) Note: I _{CCFL} is lamp current	[cd/m ²]	260 typ. (5 points average) 220 min. (5 points average) (Note1)			
Luminance Uniformity		1.25 max. (5 points)			
Contrast Ratio		500 min			
Response Time	[ms]	8 typ / 15 Max			
Nominal Input Voltage VDD	[Volt]	+3.4 typ.			
Power Consumption	[Watt]	8.7W max.			
Weight	[Grams]	680 max.			
Physical Size	[mm]		L	W	T
		Max	382.7	245.1	6.6
		Typical	382.2	-	-
		Min	381.7	-	-
Electrical Interface		2 channel LVDS			
Surface Treatment		Glare, Hardness 4H,			



Product Specification

AU OPTRONICS CORPORATION

Support Color		262K colors (RGB 6-bit)
Temperature Range Operating Storage (Non-Operating)	[°C] [°C]	0 to +50 -20 to +60
RoHS Compliance		RoHS Compliance

2.2 Optical Characteristics

The optical characteristics are measured under stable conditions at 25°C (Room Temperature) :

Item	Unit	Conditions	Min.	Typ.	Max.	Note
White Luminance I _{CCFL} =6.0mA	[cd/m ²]	5 points average	220	260	-	1, 4, 5.
Viewing Angle	[degree]	Horizontal (Right)	-	70	-	8
	[degree]	CR = 10 (Left)	-	70	-	
	[degree]	Vertical (Upper)	-	60	-	
	[degree]	CR = 10 (Lower)	-	60	-	
Luminance Uniformity		5 Points	-	-	1.25	1
CR: Contrast Ratio			500	600	-	6
Cross talk	%				4	7
Response Time	[msec]	Rising	-	-	-	8
	[msec]	Falling	-	-	-	
	[msec]	Rising + Falling	-	8	15	
Chromaticity of color Coordinates (CIE 1931)		Red x	0.590	0.620	0.650	2,8
		Red y	0.323	0.353	0.383	
		Green x	0.280	0.310	0.340	
		Green y	0.540	0.570	0.600	
		Blue x	0.126	0.156	0.186	
		Blue y	0.114	0.144	0.174	
		White x	0.283	0.313	0.343	
	White y	0.299	0.329	0.359		
NTSC	%	CIE 1931	45	50	-	



Product Specification

AU OPTRONICS CORPORATION

Note 1: 5 points position (Ref: Active area)

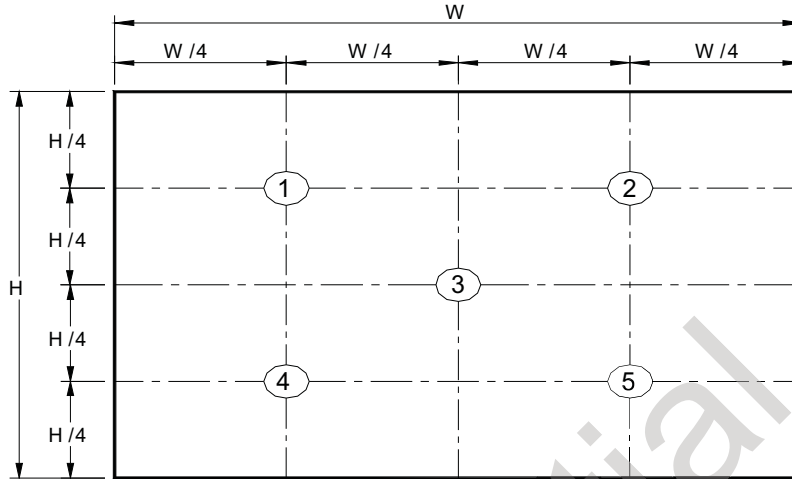

Note 2: 13 points position (Ref: Active area)

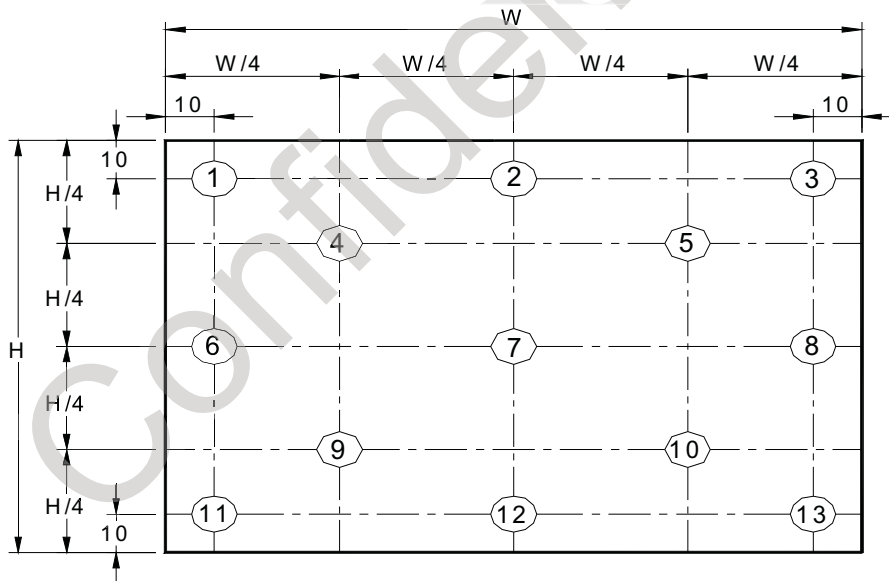

Note 3: The luminance uniformity of 5 or 13 points is defined by dividing the maximum luminance values by the minimum test point luminance

$$\delta_{w5} = \frac{\text{Maximum Brightness of five points}}{\text{Minimum Brightness of five points}}$$

$$\delta_{w13} = \frac{\text{Maximum Brightness of thirteen points}}{\text{Minimum Brightness of thirteen points}}$$

Note 4: Measurement method



Product Specification

AU OPTRONICS CORPORATION

The LCD module should be stabilized at given temperature for 30 minutes to avoid abrupt temperature change during measuring. In order to stabilize the luminance, the measurement should be executed after lighting Backlight for 30 minutes in a stable, windless and dark room.

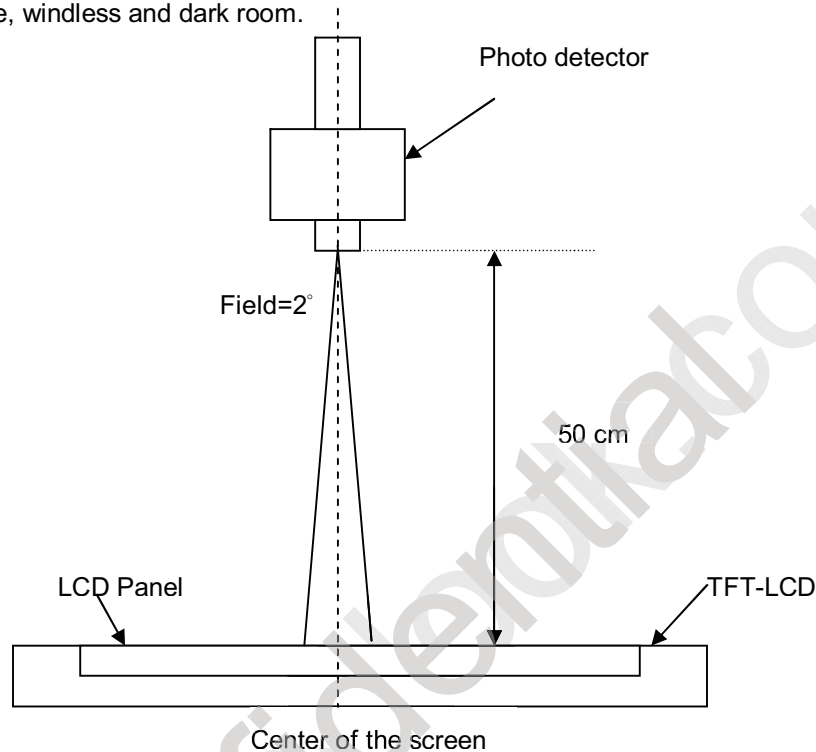

Note 5 : Definition of Average Luminance of White (Y_L):

Measure the luminance of gray level 63 at 5 points , $Y_L = [L(1) + L(2) + L(3) + L(4) + L(5)] / 5$

$L(x)$ is corresponding to the luminance of the point X at Figure in Note (1).

Note 6 : Definition of contrast ratio:

Contrast ratio is calculated with the following formula.

$$\text{Contrast ratio (CR)} = \frac{\text{Brightness on the "White" state}}{\text{Brightness on the "Black" state}}$$

Note 7 : Definition of Cross Talk (CT)

$$CT = |Y_B - Y_A| / Y_A \times 100 (\%)$$

Where

Y_A = Luminance of measured location without gray level 0 pattern (cd/m²)



Product Specification

AU OPTRONICS CORPORATION

Y_B = Luminance of measured location with gray level 0 pattern (cd/m²)

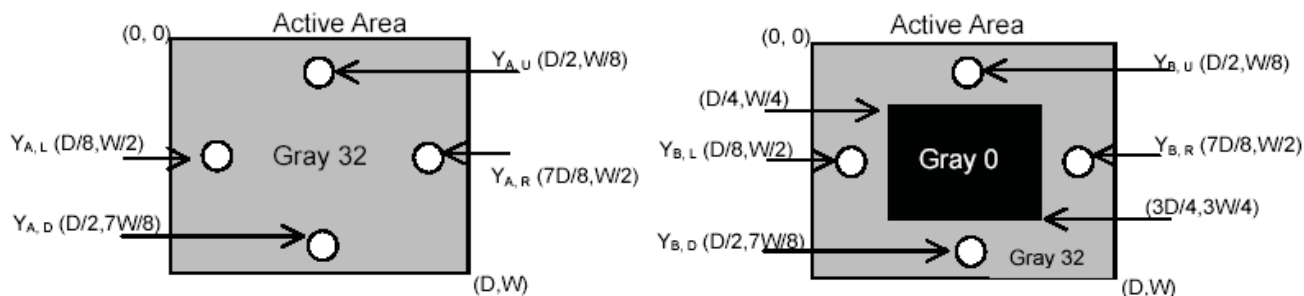

Note 8: Definition of response time:

The output signals of BM-7 or equivalent are measured when the input signals are changed from "Black" to "White" (falling time) and from "White" to "Black" (rising time), respectively. The response time interval between the 10% and 90% of amplitudes. Refer to figure as below.

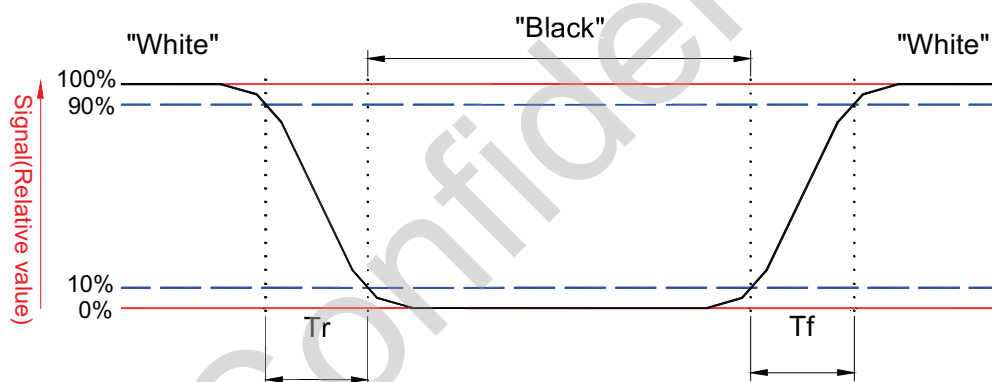



Product Specification

AU OPTRONICS CORPORATION

Note 8. Definition of viewing angle

Viewing angle is the measurement of contrast ratio ≥ 10 , at the screen center, over a 180° horizontal and 180° vertical range (off-normal viewing angles). The 180° viewing angle range is broken down as follows; 90° (θ) horizontal left and right and 90° (Φ) vertical, high (up) and low (down). The measurement direction is typically perpendicular to the display surface with the screen rotated about its center to develop the desired measurement viewing angle.

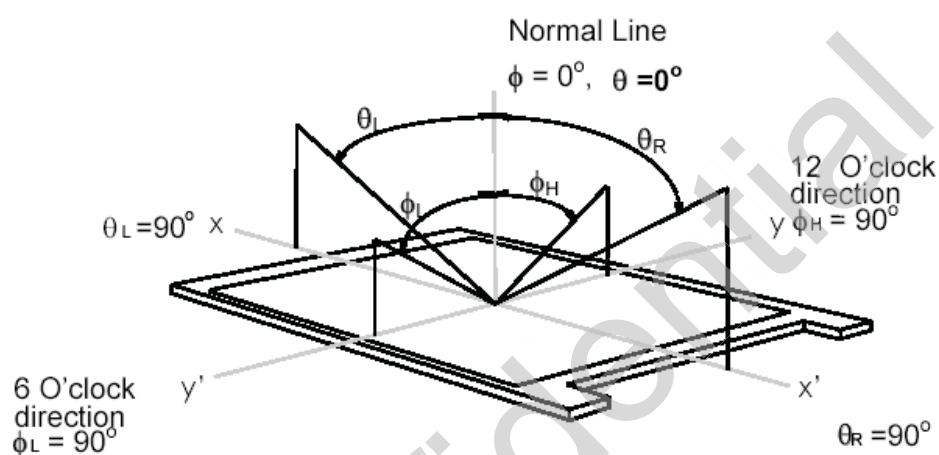



Product Specification

AU OPTRONICS CORPORATION

3. Functional Block Diagram

The following diagram shows the functional block of the 17 inches wide Color TFT/LCD Module:

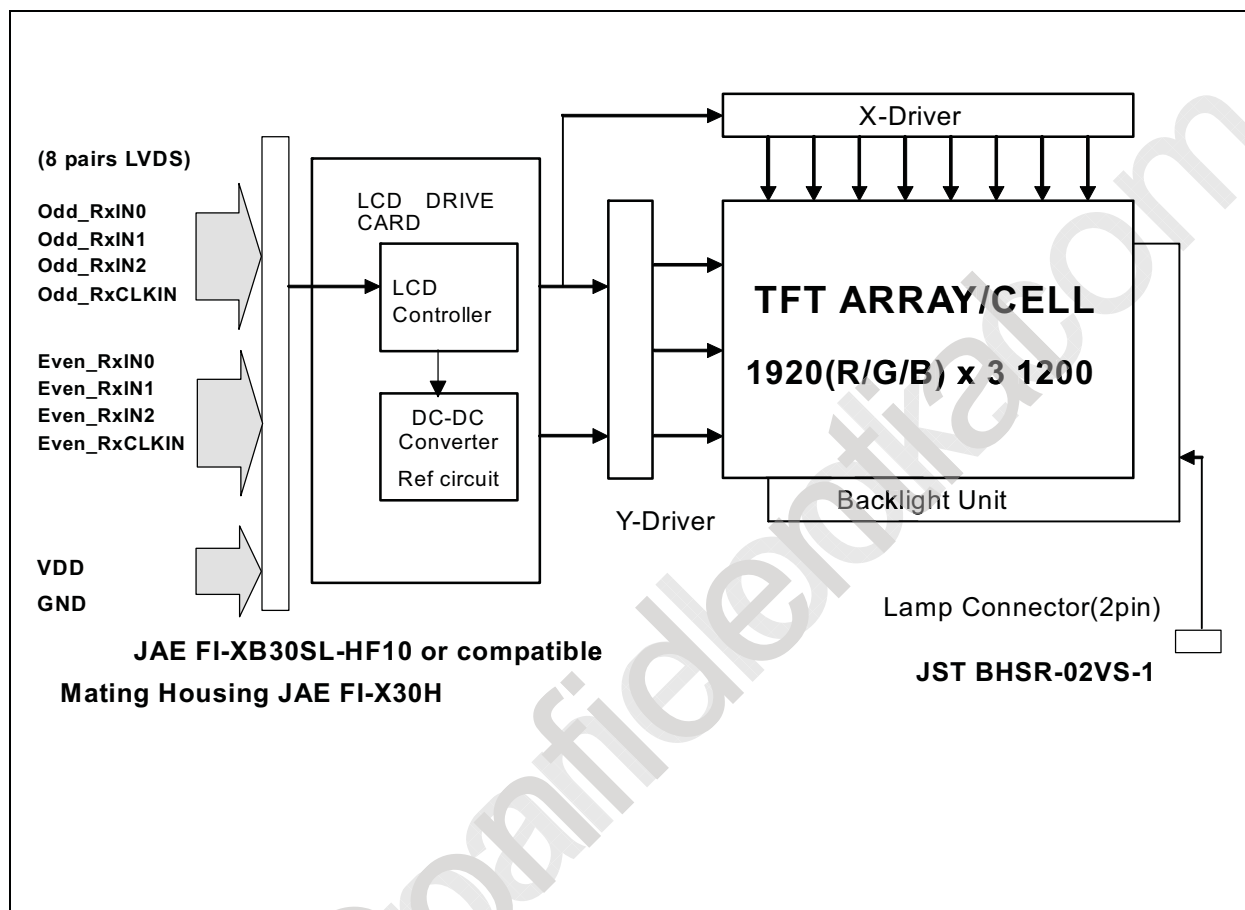



Product Specification

AU OPTRONICS CORPORATION

4. Absolute Maximum Ratings

An absolute maximum rating of the module is as following:

4.1 Absolute Ratings of TFT LCD Module

Item	Symbol	Min	Max	Unit	Conditions
Logic/LCD Drive	Vin	-0.3	+4.0	[Volt]	Note 1,2

4.2 Absolute Ratings of Backlight Unit

Item	Symbol	Min	Max	Unit	Conditions
CCFL Current	ICCFL	-	7.0	[mA] rms	Note 1,2

4.3 Absolute Ratings of Environment

Item	Symbol	Min	Max	Unit	Conditions
Operating Temperature	TOP	0	+50	[°C]	Note 3
Operation Humidity	HOP	5	95	[%RH]	Note 3
Storage Temperature	TST	-20	+60	[°C]	Note 3
Storage Humidity	HST	5	95	[%RH]	Note 3

Note 1: At Ta (25°C)

Note 2: Permanent damage to the device may occur if exceed maximum values

Note 3: For quality performance, please refer to AUO IIS (Incoming Inspection Standard).

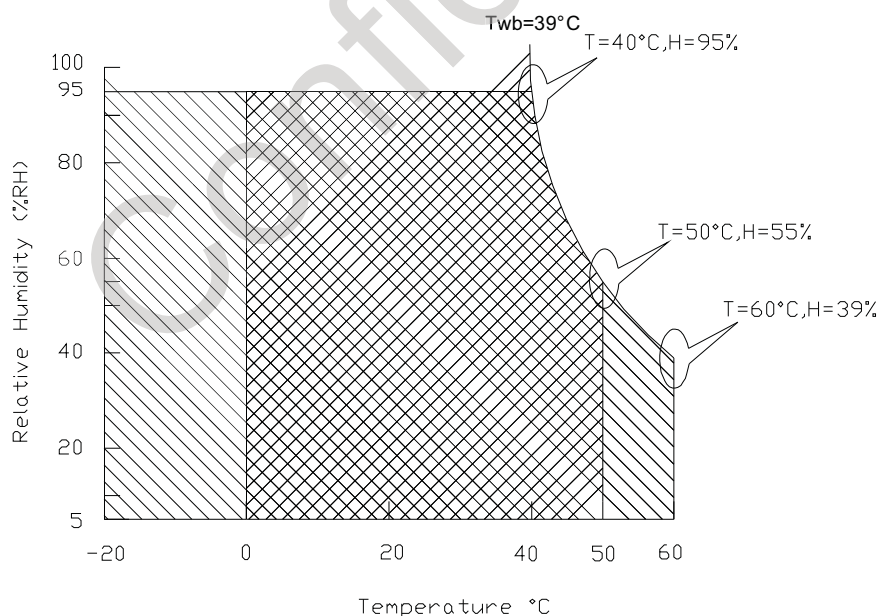



Product Specification

AU OPTRONICS CORPORATION

5. Electrical characteristics

5.1 TFT LCD Module

5.1.1 Power Specification

Input power specifications are as follows;

Symble	Parameter	Min	Typ	Max	Units	Note
VDD	Logic/LCD Drive Voltage	3.1	3.4	3.7	[Volt]	
PDD	VDD Power	-	-	3.3	[Watt]	Note 1/2
IDD	IDD Current	-	750	1000	[mA]	Note 1/2
IRush	Inrush Current	-	-	950	[mA]	Note 3
VDDrp	Allowable Logic/LCD Drive Ripple Voltage	-	-	100	[mV] p-p	

Note 1 : Maximum Measurement Condition : Black Pattern

Note 2 : Typical Measurement Condition: Mosaic Pattern

Note 3 : Measure Condition

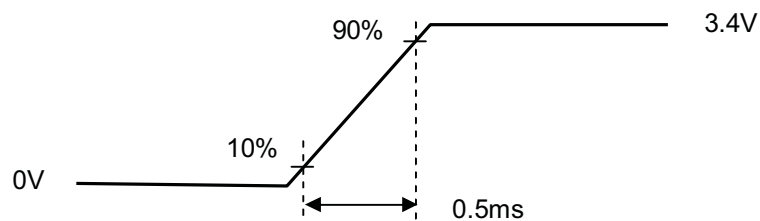
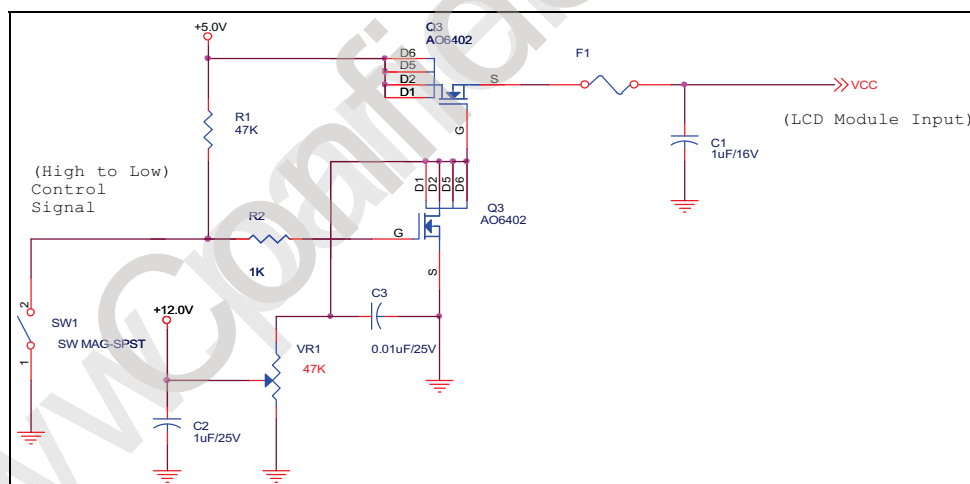

Vin rising time



Product Specification

AU OPTRONICS CORPORATION

5.1.2 Signal Electrical Characteristics

Input signals shall be low or High-impedance state when VDD is off.

It is recommended to refer the specifications of THC63LVDF84A (Thine Electronics Inc.) in detail.

Signal electrical characteristics are as follows;

Parameter	Condition	Min	Max	Unit
V _{th}	Differential Input High Threshold (V _{cm} =+1.2V)	100		[mV]
V _{tl}	Differential Input Low Threshold (V _{cm} =+1.2V)	-100		[mV]
V _{cm}	Differential Input Common Mode Voltage	1.125	1.375	[V]

Note: LVDS Signal Waveform

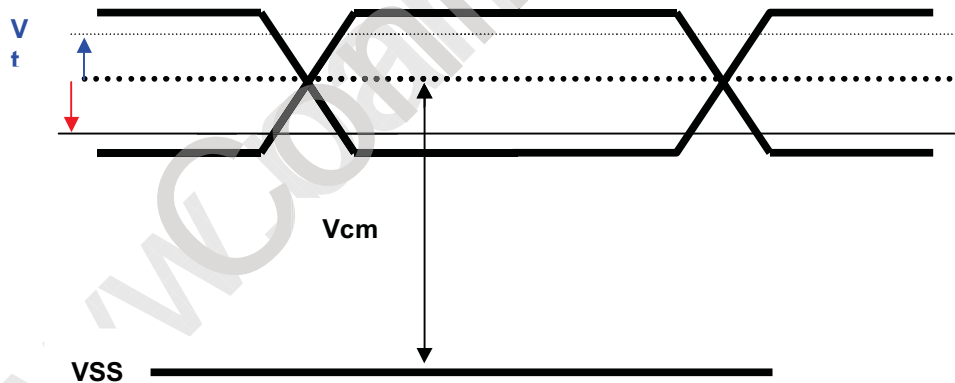



Product Specification

AU OPTRONICS CORPORATION

5.2 Backlight Unit

CCFL Parameter guideline for CCFL Inverter selection (Ref. Remark 1)

Parameter	Min	Typ	Max	Units	Condition
CCFL current(I_{CCFL})	2.0	6.0	7.0	[mA] rms	(Ta=25°C) Note 1
CCFL Frequency(F_{CCFL})	40	60	80	[KHz]	(Ta=25°C) Note 2,3
CCFL startup Voltage(V_s)			1450	[Volt] rms	(Ta= 0°C) Note 4
CCFL startup Voltage(V_s)			1210	[Volt] rms	(Ta= 25°C) Note 4
CCFL Voltage (Reference) (V_{CCFL})	666	740	814	[Volt] rms	(Ta=25°C) Note 5
CCFL Power consumption (P_{CCFL})	-	4.44	5.20	[Watt]	(Ta=25°C) Note 5
CCFL Life-Time	10,000	-	-	Hour	(Ta=25°C) Note 7

Remark 1: Typ are AUO recommended Design Points.

1-1 All of characteristics listed are measured under the condition using the AUO Test inverter.

1-2 In case of using an inverter other than listed, it is recommended to check the inverter carefully.

Sometimes, interfering noise stripes appear on the screen, and substandard luminance or flicker at low power may happen.

1-3 In designing an inverter, it is suggested to check safety circuit very carefully. Impedance of CCFL, for instance, becomes more than 1 [M ohm] when CCFL is damaged.

1-4 Generally, CCFL has some amount of delay time after applying starting voltage. It is recommended to keep on applying starting voltage for **1 [Sec]** until discharge.

1-5 CCFL discharge frequency must be carefully chosen so as not to produce interfering noise stripes on the screen.

1-6 Reducing CCFL current increases CCFL discharge voltage and generally increases CCFL discharge frequency. So all the parameters of an inverter should be carefully designed so as not to produce too much leakage current from high-voltage output of the inverter.



Product Specification

AU OPTRONICS CORPORATION

Note 1: It should be employed the inverter which has "Duty Dimming", if ICCFL is less than 4mA.

Note 2: CCFL discharge frequency should be carefully determined to avoid interference between inverter and TFT LCD.

Note 3: The frequency range will not affect to lamp life and reliability characteristics.

Note 4: **The output voltage of inverter should be able to give out a power after ballast capacitor , the generating capacity have to be larger than a lamp startup voltage**, otherwise backlight may has blinking for a moment after turns on or can not be turned on.

Note 5: Calculator value for reference ($ICCFL \times VCCFL = PCCFL$)

Note 6: Requirements for a system inverter design, which is intended to have a better display performance, a better power efficiency and a more reliable lamp, are following.

It shall help increase the lamp lifetime and reduce leakage current.

a. The asymmetry rate of the inverter waveform should be less than 10%.

b. The distortion rate of the waveform should be within $\sqrt{2} \pm 10\%$.

* Inverter output waveform had better be more similar to ideal sine wave.

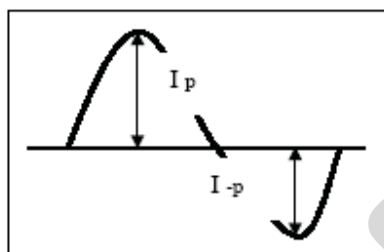

* Asymmetry rate:

$$\frac{|I_p - I_{-p}|}{I_{rms}} * 100\%$$

* Distortion rate

$$I_p \text{ (or } I_{-p}) / I_{rms}$$

Note 7: It is an edge-type BLU with single CCFL, the life-time define as the brightness decay to 50% of original value and under normal operation.



Product Specification

AU OPTRONICS CORPORATION

6. Signal Characteristic

6.1 Pixel Format Image

Following figure shows the relationship of the input signals and LCD pixel format.

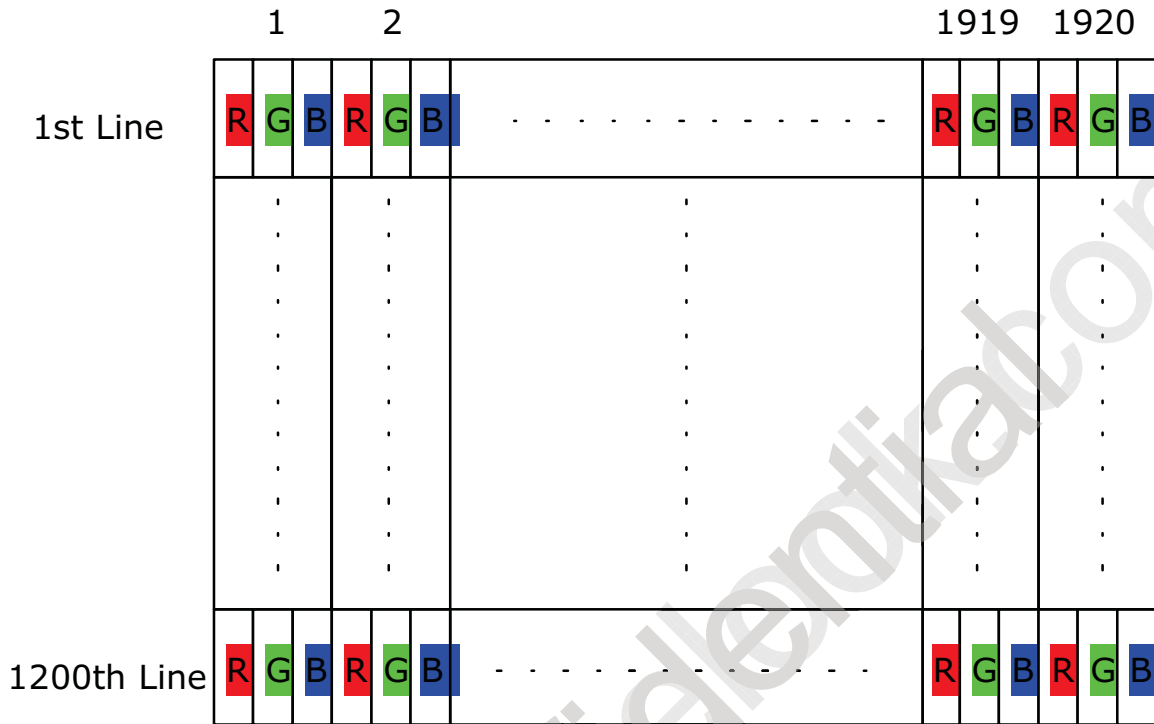



Product Specification

AU OPTRONICS CORPORATION

6.2 The input data format

ODD pair(1st pixel input)

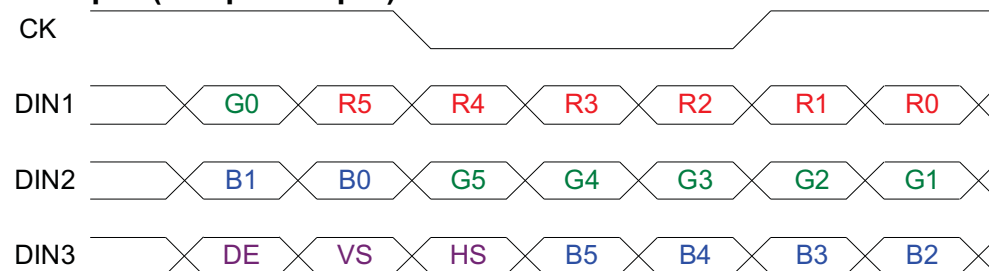

Even pair(2nd pixel input)

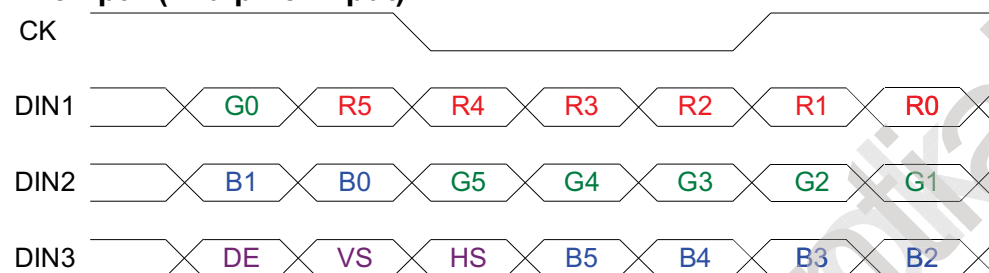

Signal Name	Description	
R5 R4 R3 R2 R1 R0	Red Data 5 (MSB) Red Data 4 Red Data 3 Red Data 2 Red Data 1 Red Data 0 (LSB) Red-pixel Data	Red-pixel Data Each red pixel's brightness data consists of these 6 bits pixel data.
G5 G4 G3 G2 G1 G0	Green Data 5 (MSB) Green Data 4 Green Data 3 Green Data 2 Green Data 1 Green Data 0 (LSB) Green-pixel Data	Green-pixel Data Each green pixel's brightness data consists of these 6 bits pixel data.
B5 B4 B3 B2 B1 B0	Blue Data 5 (MSB) Blue Data 4 Blue Data 3 Blue Data 2 Blue Data 1 Blue Data 0 (LSB) Blue-pixel Data	Blue-pixel Data Each blue pixel's brightness data consists of these 6 bits pixel data.
RxCLKIN	Data Clock	The typical frequency is 78.5 MHz. The signal is used to strobe the pixel data and DSPTMG signals. All pixel data shall be valid at the falling edge when the DSPTMG signal is high.
DE	Display Timing	This signal is strobed at the falling edge of -DTCLK. When the signal is high, the pixel data shall be valid to be displayed.
VS	Vertical Sync	The signal is synchronized to -DTCLK .
HS	Horizontal Sync	The signal is synchronized to -DTCLK .

Note: Output signals from any system shall be low or High-Z state when VDD is off.



Product Specification

AU OPTRONICS CORPORATION

6.3 Signal Description/Pin Assignment

LVDS is a differential signal technology for LCD interface and high speed data transfer device.

	Symbol	Function
1	GND	Ground
2	VDD	Power supply ,3.4 V (typical)
3	VDD	Power supply ,3.4 V (typical)
4	V _{EDID}	DDC 3.3V power
5	NC	No Connection (Reserved for AUO) test
6	CLK _{EDID}	DDC Clock
7	Data _{EDID}	DDC data
8	Odd_RxIN0-	-LVDS differential data input
9	Odd_RxIN0+	+LVDS differential data input
10	GND	Ground
11	Odd_RxIN1-	-LVDS differential data input
12	Odd_RxIN1+	+LVDS differential data input
13	GND	Ground
14	Odd_RxIN2-	-LVDS differential data input
15	Odd_RxIN2+	+LVDS differential data input
16	GND	Ground
17	Odd_RxCLKIN-	-LVDS differential clock input
18	Odd_RxCLKIN+	+LVDS differential clock input
19	GND	Ground
20	Even_RxIN0-	-LVDS differential data input
21	Even_RxIN0+	+LVDS differential data input
22	GND	Ground
23	Even_RxIN1-	-LVDS differential data input
24	Even_RxIN1+	+LVDS differential data input
25	GND	Ground
26	Even_RxIN2-	-LVDS differential data input
27	Even_RxIN2+	+LVDS differential data input
28	GND	Ground
29	Even_RxCLKIN-	-LVDS differential clock input
30	Even_RxCLKIN+	+LVDS differential clock input



Product Specification

AU OPTRONICS CORPORATION

Note1: Start from right side

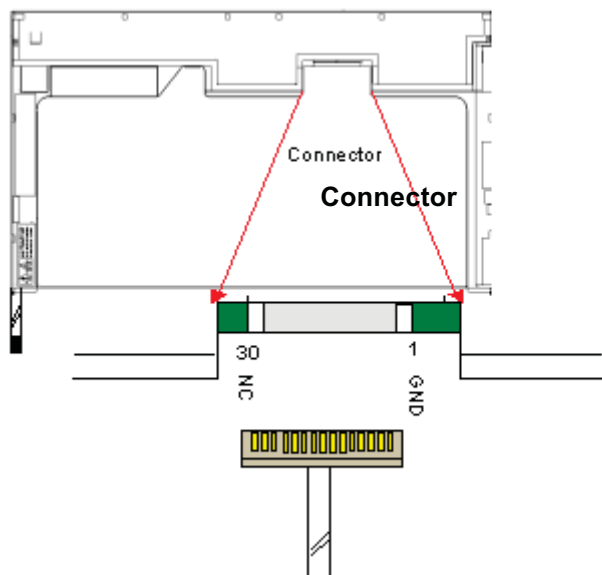

Note2: Input signals shall be low or High-impedance state when VDD is off.
internal circuit of LVDS inputs are as following.

The module uses a 100ohm resistor between positive and negative data lines of each receiver input

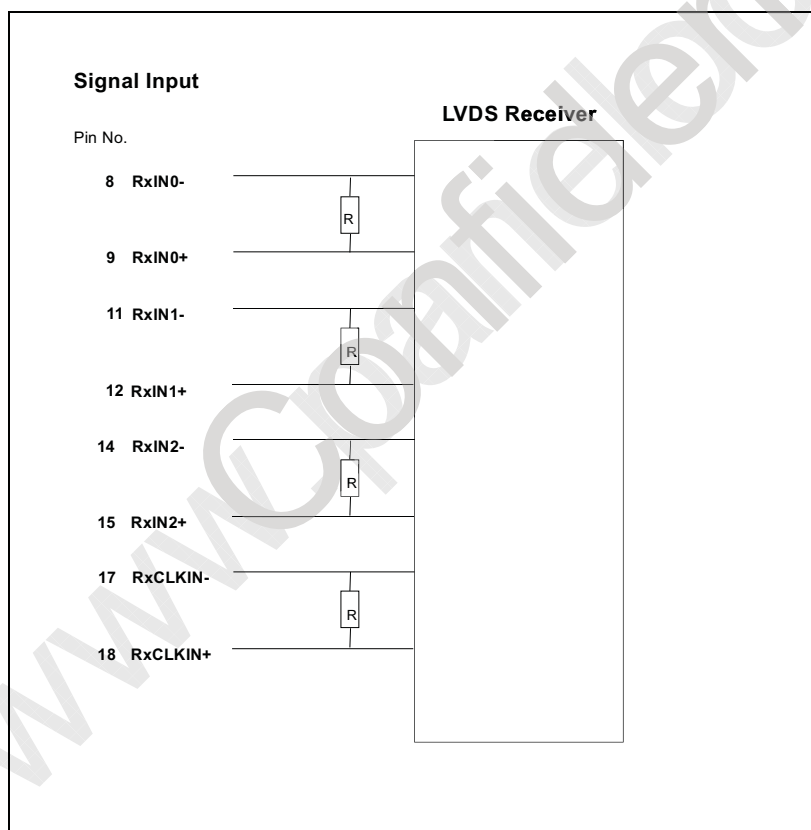



Product Specification

AU OPTRONICS CORPORATION

6.4 Interface Timing

6.4.1 Timing Characteristics

Basically, interface timings should match the 1920x1200 /60Hz manufacturing guide line timing.

Parameter	Symbol	Min.	Typ.	Max.	Unit	
Frame Rate	-	50	60	-	Hz	
Clock frequency	$1/T_{\text{Clock}}$	78.5	78.75	80	MHz	
Vertical Section	Period	T_V	1208	1246	2047	T_{Line}
	Active	T_{VD}	1200	1200		
	Blanking	T_{VB}	8	46		
Horizontal Section	Period	T_H	990	1050	2047	T_{Clock}
	Active	T_{HD}	960	960	-	
	Blanking	T_{HB}	30	90		

Note : DE mode only



Product Specification

AU OPTRONICS CORPORATION

6.4.2 Timing diagram

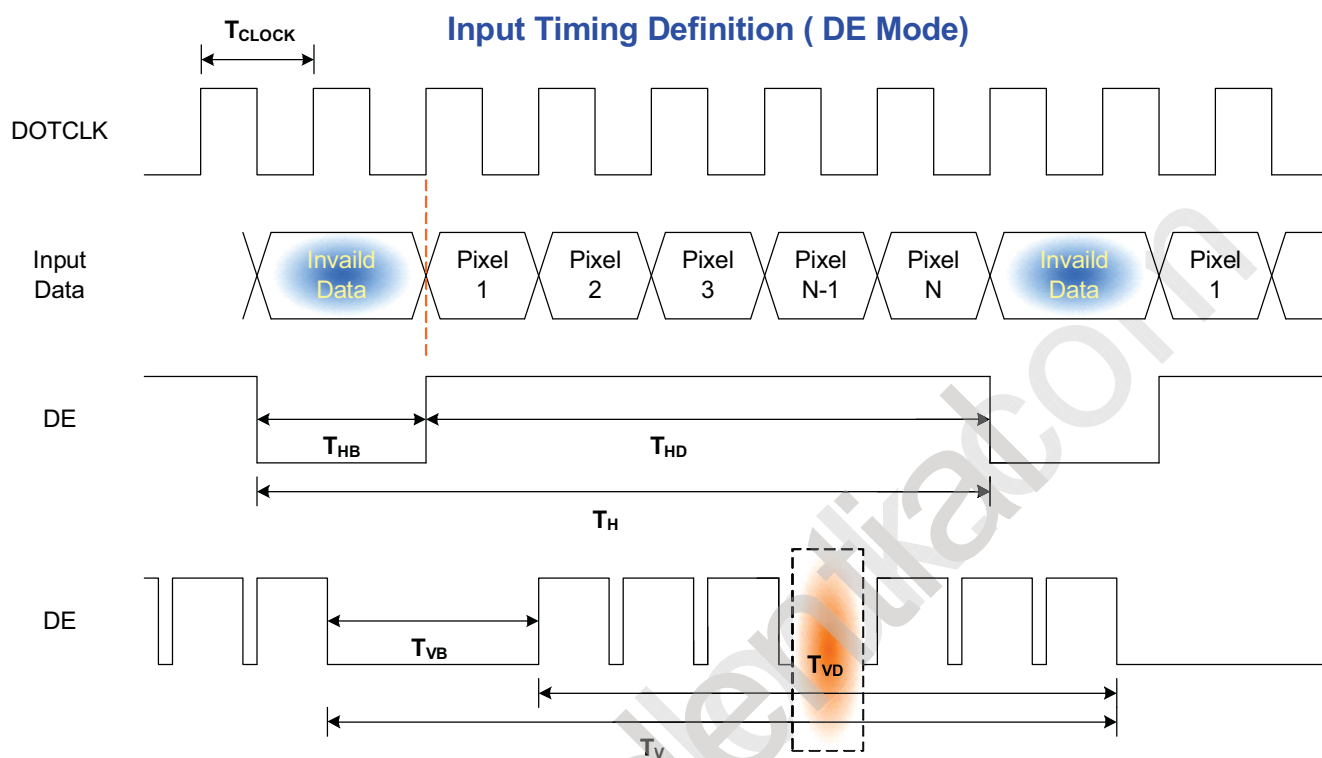



Product Specification

AU OPTRONICS CORPORATION

6.5 Power ON/OFF Sequence

VDD power and lamp on/off sequence is as follows. Interface signals are also shown in the chart. Signals from any system shall be Hi-Z state or low level when VDD is off.

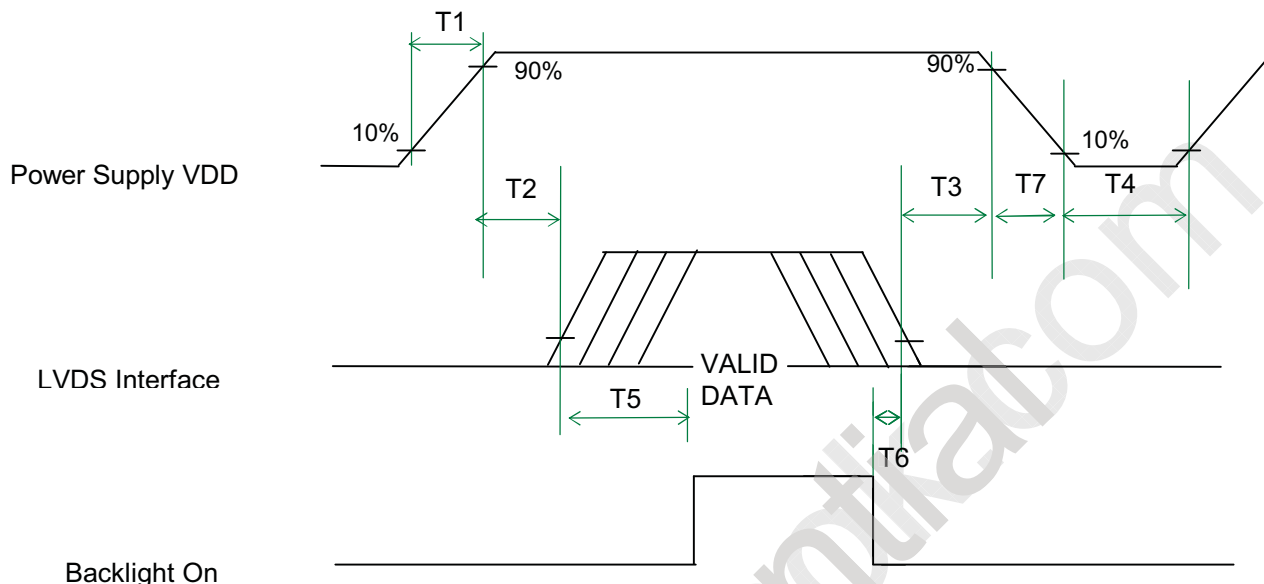

Power Sequence Timing

Parameter	Value			Units
	Min.	Typ.	Max.	
T1	0.5	-	10	(ms)
T2	0	-	50	(ms)
T3	0	-	50	(ms)
T4	400	-	-	(ms)
T5	200	-	-	(ms)
T6	200	-	-	(ms)
T7	0	-	10	(ms)



Product Specification

AU OPTRONICS CORPORATION

7. Connector Description

Physical interface is described as for the connector on module.

These connectors are capable of accommodating the following signals and will be following components.

7.1 TFT LCD Module

Connector Name / Designation	For Signal Connector
Manufacturer	JAE or compatible
Type / Part Number	FI-XB30SL-HF10 or compatible
Mating Housing/Part Number	FI-X30H

7.2 Backlight Unit

Physical interface is described as for the connector on module.

These connectors are capable of accommodating the following signals and will be following components.

Connector Name / Designation	For Lamp Connector
Manufacturer	JST
Type / Part Number	BHSR-02VS-1
Mating Type / Part Number	SM02B-BHSS-1-TB

7.3 Signal for Lamp connector

Pin #	Cable color	Signal Name
1	Pink	Lamp High Voltage
2	White	Lamp Low Voltage



Product Specification

AU OPTRONICS CORPORATION

8. Dynamic Test

8.1 Vibration Test

Test condition:

- Acceleration: 1.5 G
- Frequency: 10 - 500Hz Random
- Sweep: 30 Minutes each Axis (X, Y, Z)

8.2 Shock Test Spec:

Test condition:

- Acceleration: 220 G , Half sine wave
- Active time: 2 ms
- Pulse: +/-X,+/-Y,+/-Z , one time for each side

Remark:

1. Ambient condition is $25 \pm 5^{\circ}\text{C}$, Relative humidity : 40% ~ 70%
2. Non-packaged and Non-operation



Product Specification

AU OPTRONICS CORPORATION

9. Reliability

Items	Required Condition	Note
Temperature Humidity Bias	Ta= 40°C, 90%RH, 300h	
High Temperature Operation	Ta= 50°C, Dry, 300h	
Low Temperature Operation	Ta= 0°C, 300h	
High Temperature Storage	Ta= 60°C, 35%RH, 300h	
Low Temperature Storage	Ta= -20°C, 50%RH, 300h	
Thermal Shock Test	Ta=-20°C to 60°C, Duration at 30 min, 100 cycles	
ESD	Contact : ±8 KV Air : ±15 KV	Note 1

Note1: According to EN 61000-4-2 , ESD class B: Some performance degradation allowed. No data lost
 . Self-recoverable. No hardware failures.

Remark: MTBF (Excluding the CCFL): 30,000 hours with a confidence level 90%

10. Mechanical Characteristics

10.1 LCM Outline Dimension

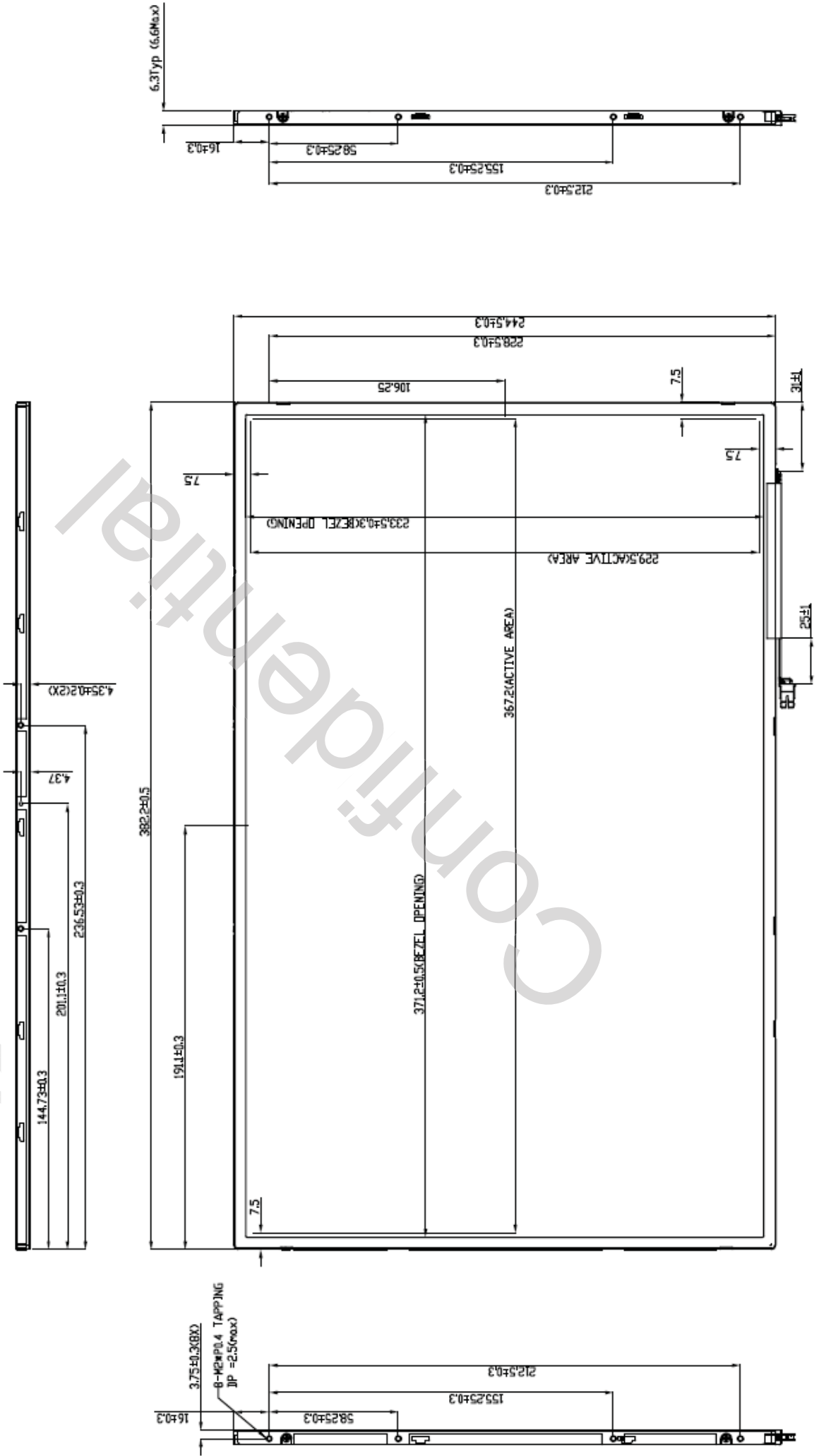



Product Specification

AU OPTRONICS CORPORATION

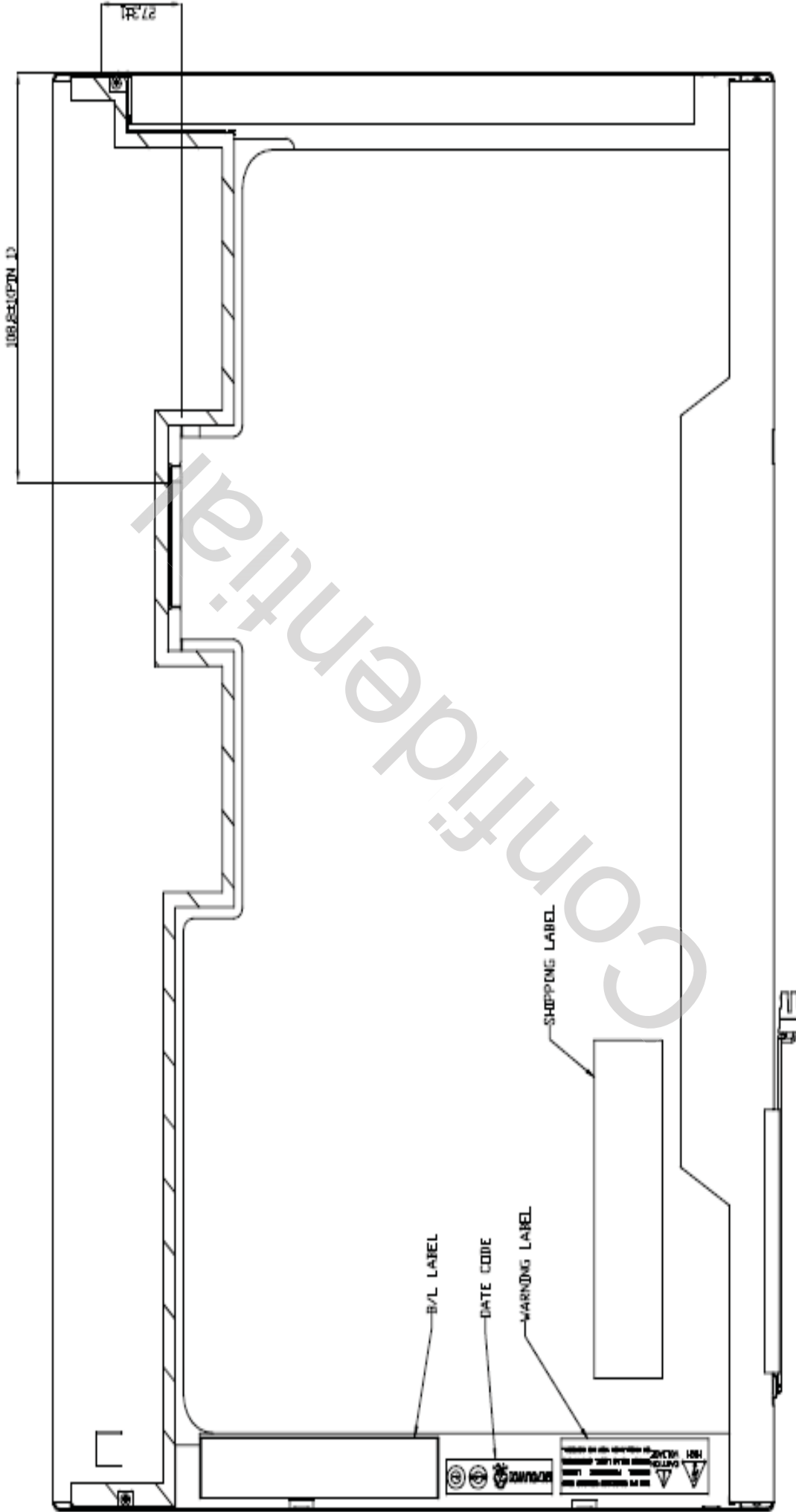



Product Specification

AU OPTRONICS CORPORATION

10.2 Screw Hole Depth and Center Position

Screw hole minimum depth, from side surface = 2.6 mm (See drawing)

Screw hole center location, from front surface = 3.75 ± 0.2 mm (See drawing)

Screw maximum length = 2.3 mm (See drawing)

Screw Torque: Maximum 2.5 kgzf-cm

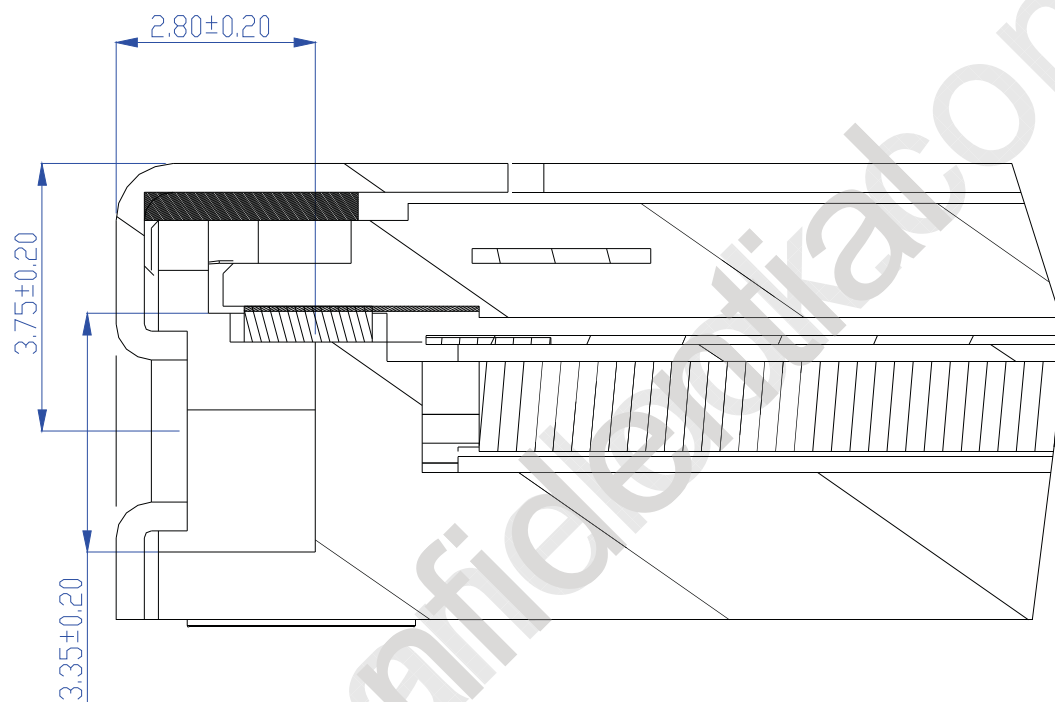



Product Specification

AU OPTRONICS CORPORATION

11. Shipping and Package

11.1 Shipping Label Format

 *XXXXXXXXXXXX-XXXXXX	Manufactured xxx/xx Model No: B170UW01 V2 AU Optronics 1AXXG MADE IN TAIWAN (M1) HW: 1A FW:1	  
---	--	---



Product Specification

AU OPTRONICS CORPORATION

11.2 Carton package

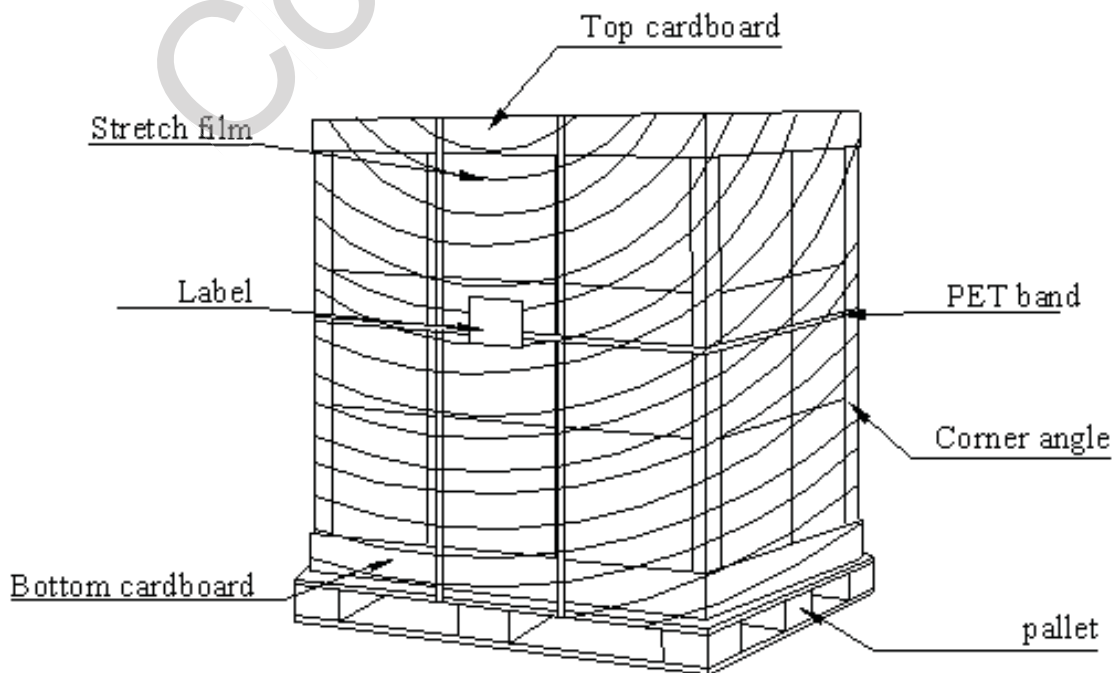
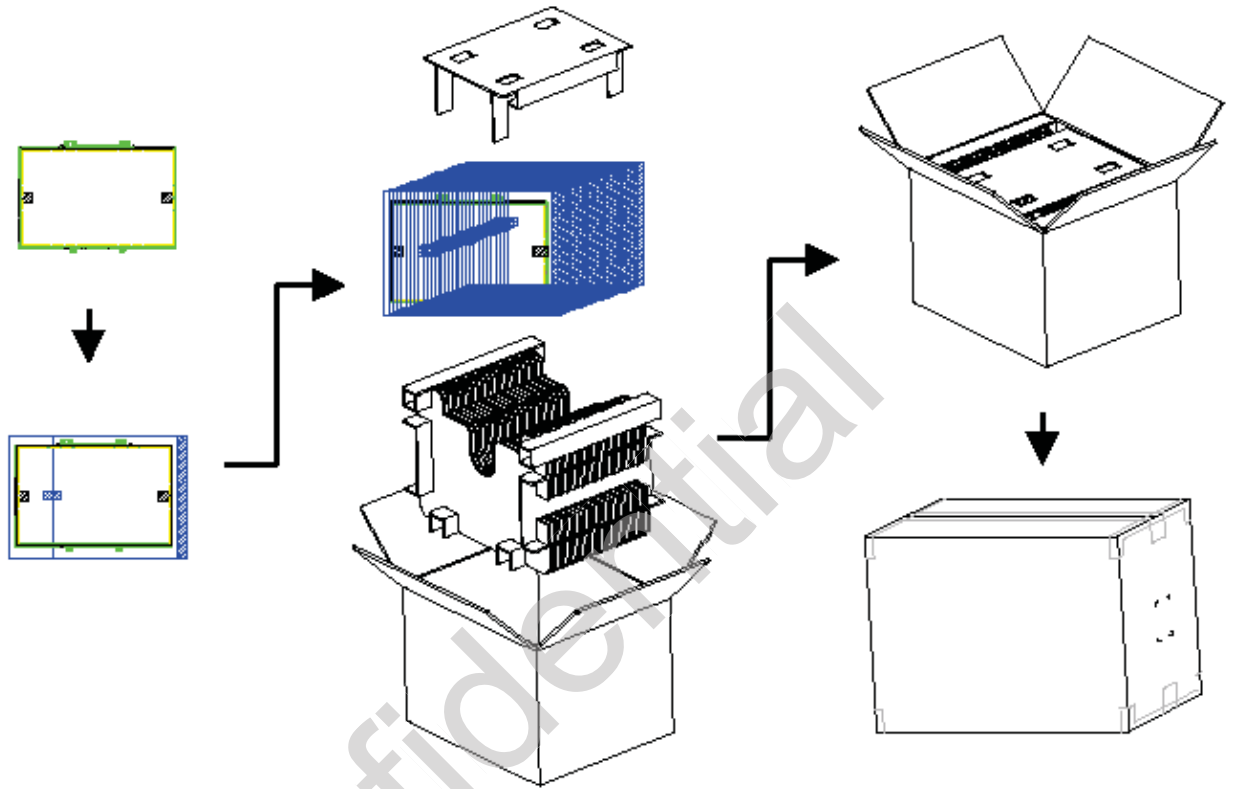



Product Specification

AU OPTRONICS CORPORATION

12. Appendix: EDID description

B170UW01 V2 EDID Code

Address	FUNCTION	Value	Value	Value	Note
HEX		HEX	BIN	DEC	
00	Header	00	00000000	0	
01		FF	11111111	255	
02		FF	11111111	255	
03		FF	11111111	255	
04		FF	11111111	255	
05		FF	11111111	255	
06		FF	11111111	255	
07		00	00000000	0	
08	EISA Manuf. Code LSB	06	00000110	6	
09	Compressed ASCII	AF	10101111	175	
0A	Product Code	88	10001000	136	
0B	hex, LSB first	12	00010010	18	
0C	32-bit ser #	00	00000000	0	
0D		00	00000000	0	
0E		00	00000000	0	
0F		00	00000000	0	
10	Week of manufacture	01	00000001	1	
11	Year of manufacture	12	00010010	18	
12	EDID Structure Ver.	01	00000001	1	
13	EDID revision #	03	00000011	3	
14	Video input def. (<i>digital I/P, non-TMDS, CRGB</i>)	80	10000000	128	
15	Max H image size (<i>rounded to cm</i>)	25	00100101	37	
16	Max V image size (<i>rounded to cm</i>)	17	00010111	23	
17	Display Gamma (<i>=(gamma*100)-100</i>)	78	01111000	120	
18	Feature support (<i>no DPMS, Active OFF, RGB, tmg Blk#1</i>)	0A	00001010	10	
19	Red/green low bits (Lower 2:2:2 bits)	67	01100111	103	
1A	Blue/white low bits (Lower 2:2:2 bits)	B5	10110101	181	
1B	Red x (Upper 8 bits)	A1	10100001	161	
1C	Red y/ highER 8 bits	59	01011001	89	
1D	Green x	4F	01001111	79	
1E	Green y	8C	10001100	140	
1F	Blue x	2B	00101011	43	
20	Blue y	23	00100011	35	
21	White x	50	01010000	80	
22	White y	54	01010100	84	
23	Established timing 1	00	00000000	0	
24	Established timing 2	00	00000000	0	



Product Specification

AU OPTRONICS CORPORATION

25	Established timing 3	00	00000000	0	
26	Standard timing #1	01	00000001	1	
27		01	00000001	1	
28	Standard timing #2	01	00000001	1	
29		01	00000001	1	
2A	Standard timing #3	01	00000001	1	
2B		01	00000001	1	
2C	Standard timing #4	01	00000001	1	
2D		01	00000001	1	
2E	Standard timing #5	01	00000001	1	
2F		01	00000001	1	
30	Standard timing #6	01	00000001	1	
31		01	00000001	1	
32	Standard timing #7	01	00000001	1	
33		01	00000001	1	
34	Standard timing #8	01	00000001	1	
35		01	00000001	1	
36	Pixel Clock/10000 LSB	54	01010100	84	
37	Pixel Clock/10000 USB	3D	00111101	61	
38	Horz active Lower 8bits	80	10000000	128	
39	Horz blanking Lower 8bits	B4	10110100	180	
3A	HorzAct:HorzBlnk Upper 4:4 bits	70	01110000	112	
3B	Vertical Active Lower 8bits	B0	10110000	176	
3C	Vertical Blanking Lower 8bits	2E	00101110	46	
3D	Vert Act : Vertical Blanking (upper 4:4 bit)	40	01000000	64	
3E	HorzSync. Offset	30	00110000	48	
3F	HorzSync.Width	20	00100000	32	
40	VertSync.Offset : VertSync.Width	36	00110110	54	
41	Horz&Vert Sync Offset/Width Upper 2bits	00	00000000	0	
42	Horizontal Image Size Lower 8bits	6F	01101111	111	
43	Vertical Image Size Lower 8bits	E5	11100101	229	
44	Horizontal & Vertical Image Size (upper 4:4 bits)	10	00010000	16	
45	Horizontal Border <i>(zero for internal LCD)</i>	00	00000000	0	
46	Vertical Border <i>(zero for internal LCD)</i>	00	00000000	0	
47	Signal <i>(non-intr, norm, no stero, sep sync, neg pol)</i>	18	00011000	24	
48	Detailed timing/monitor	00	00000000	0	
49	descriptor #2	00	00000000	0	
4A		00	00000000	0	
4B		0F	00001111	15	
4C		00	00000000	0	
4D		00	00000000	0	
4E		00	00000000	0	
4F		00	00000000	0	



Product Specification

AU OPTRONICS CORPORATION

50		00	00000000	0	
51		00	00000000	0	
52		00	00000000	0	
53		00	00000000	0	
54		00	00000000	0	
55		00	00000000	0	
56		00	00000000	0	
57		00	00000000	0	
58		00	00000000	0	
59		20	00100000	32	
5A	Detailed timing/monitor	00	00000000	0	
5B	descriptor #3	00	00000000	0	
5C		00	00000000	0	
5D		FE	11111110	254	
5E		00	00000000	0	
5F	Manufacture	41	01000001	65	A
60	Manufacture	55	01010101	85	U
61	Manufacture	4F	01001111	79	O
62		0A	00001010	10	
63		20	00100000	32	
64		20	00100000	32	
65		20	00100000	32	
66		20	00100000	32	
67		20	00100000	32	
68		20	00100000	32	
69		20	00100000	32	
6A		20	00100000	32	
6B		20	00100000	32	
6C	Detailed timing/monitor	00	00000000	0	
6D	descriptor #4	00	00000000	0	
6E		00	00000000	0	
6F		FE	11111110	254	
70		00	00000000	0	
71	Manufacture P/N	42	01000010	66	B
72	Manufacture P/N	31	00110001	49	1
73	Manufacture P/N	37	00110111	55	7
74	Manufacture P/N	30	00110000	48	0
75	Manufacture P/N	55	01010101	85	U
76	Manufacture P/N	57	01010111	87	W
77	Manufacture P/N	30	00110000	48	0
78	Manufacture P/N	31	00110001	49	1
79	Manufacture P/N	20	00100000	32	
7A	Manufacture P/N	56	01010110	86	V



Product Specification

AU OPTRONICS CORPORATION

7B	Manufacture P/N	32	00110010	50	2
7C		20	00100000	32	
7D		0A	00001010	10	
7E	Extension Flag	00	00000000	0	
7F	Checksum	27	00100111	39	
SUM				6400	