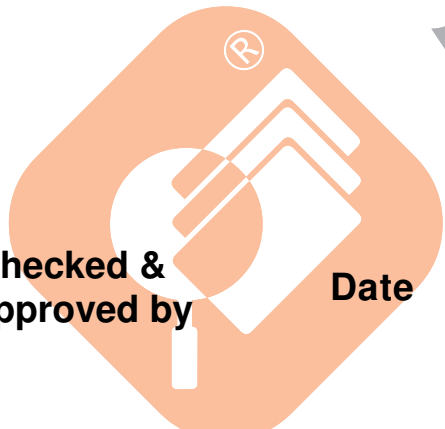

( V ) Preliminary Specifications

( ) Final Specifications

<b>Module</b>	<b>17.3"(17.26") FHD 16:9 Color TFT-LCD with LED Backlight design</b>
<b>Model Name</b>	<b>B173HAN01.0 (HW:2A)</b>
<b>Note ( )</b>	<b><i>LED Backlight with driving circuit design</i></b>

<b>Customer</b>	<b>Date</b>
	
<b>Checked &amp; Approved by</b>	<b>Date</b>
<p>Note: This Specification is subject to change without notice.</p>	

<b>Approved by</b>	<b>Date</b>
<u>Wen Hua</u>	<u>02/03/2015</u>
<b>Prepared by</b>	<b>Date</b>
<u>AmandaHJLiao</u>	<u>02/03/2015</u>
<b>NBBU Marketing Division</b> <b>AU Optronics corporation</b>	

## Contents

<b>1. Handling Precautions</b> .....	<b>4</b>
<b>2. General Description</b> .....	<b>5</b>
2.1 General Specification.....	5
2.2 Optical Characteristics.....	6
<b>3. Functional Block Diagram</b> .....	<b>11</b>
4.1 Absolute Ratings of TFT LCD Module.....	12
4.2 Absolute Ratings of Environment.....	12
<b>5. Electrical Characteristics</b> .....	<b>13</b>
5.1 TFT LCD Module.....	13
5.2 Backlight Unit.....	16
<b>6. Signal Interface Characteristic</b> .....	<b>17</b>
6.1 Pixel Format Image.....	17
6.2 The Input Data Format.....	17
6.3 Integration Interface Requirement.....	18
6.4 Interface Timing.....	20
6.5 Power ON/OFF Sequence.....	21
<b>7. Panel Reliability Test</b> .....	<b>24</b>
7.1 Vibration Test.....	24
7.2 Shock Test.....	24
7.3 Reliability Test.....	24
<b>8. Mechanical Characteristics</b> .....	<b>25</b>
8.1 LCM Outline Dimension.....	25
<b>9. Shipping and Package</b> .....	<b>27</b>
9.1 Shipping Label Format.....	27
9.2 Carton Package.....	27
9.3 Shipping Package of Palletizing Sequence.....	28
<b>10. Appendix: EDID Description</b> .....	<b>29</b>



# Product Specification

AU OPTRONICS CORPORATION

## Record of Revision

Version and Date	Page	Old description	New Description	Remark
0.1 2014/12/17	All	First Edition for Customer		
0.2 2015/02/03	29	Appendix: EDID Description TBD	Appendix: EDID Description Detail data	



SPLCD.com  
Supply & Purchase Cloud Platform

## 1. Handling Precautions

- 1) Since front polarizer is easily damaged, pay attention not to scratch it.
- 2) Be sure to turn off power supply when inserting or disconnecting from input connector.
- 3) Wipe off water drop immediately. Long contact with water may cause discoloration or spots.
- 4) When the panel surface is soiled, wipe it with absorbent cotton or other soft cloth.
- 5) Since the panel is made of glass, it may break or crack if dropped or bumped on hard surface.
- 6) Since CMOS LSI is used in this module, take care of static electricity and insure human earth when handling.
- 7) Do not open nor modify the Module Assembly.
- 8) Do not press the reflector sheet at the back of the module to any directions.
- 9) At the insertion or removal of the Signal Interface Connector, be sure not to rotate nor tilt the Interface Connector of the TFT Module.
- 10) After installation of the TFT Module into an enclosure (Notebook PC Bezel, for example), do not twist nor bend the TFT Module even momentarily. At designing the enclosure, it should be taken into consideration that no bending/twisting forces are applied to the TFT Module from outside. Otherwise the TFT Module may be damaged.
- 11) Small amount of materials having no flammability grade is used in the LCD module. The LCD module should be supplied by power complied with requirements of Limited Power Source (IEC60950 or UL1950), or be applied exemption.
- 12) Disconnecting power supply before handling LCD modules, it can prevent electric shock, DO NOT TOUCH the electrode parts, cables, connectors and LED circuit part of TFT module that a LED light bar build in as a light source of back light unit. It can prevent electrostatic breakdown.

## 2. General Description

B173HAN01.0 is a Color Active Matrix Liquid Crystal Display composed of a TFT LCD panel, a driver circuit, and LED backlight system. The screen format is intended to support the 16:9 FHD, 1920(H) x 1080(V) screen and 262k colors (RGB 6-bits data driver) with LED backlight driving circuit. All input signals are eDP interface compatible.

B173HAN01.0 is designed for a display unit of notebook style personal computer and industrial machine.

### 2.1 General Specification

The following items are characteristics summary on the table at 25 °C condition:

Items	Unit	Specifications			
Screen Diagonal	[mm]	17.3"(17.26)			
Active Area	[mm]	381.888 x 214.812			
Pixels H x V		1920 x 3 (RGB) x 1080			
Pixel Pitch	[mm]	0.1989 x 0.1989			
Pixel Format		TBD			
Display Mode		Normally Black			
White Luminance (ILED=22mA) (Note: ILED is LED current)	[cd/m <sup>2</sup> ]	300 typ. (5 points average) 250 min. (5 points average)			
Luminance Uniformity		1.25 max. (5 points)			
Contrast Ratio		700 typ			
Response Time	[ms]	25 typ			
Nominal Input Voltage VDD	[Volt]	+3.3 typ.			
Power Consumption	[Watt]	6.6W Max (Max: includ Logic@mosaic & BL power)			
Weight	[Grams]	550g max			
Physical Size	[mm]		Min.	Typ.	Max.
		Length	397.6	398.1	398.6
		Width	250	250.5	251
		Thickness	-	-	4
Electrical Interface		2 Lane eDP 1.2			



# Product Specification

AU OPTRONICS CORPORATION

Glass Thickness	[mm]	0.5
Surface Treatment		Anti-Glare, Hardness 3H
Support Color		6-bit + FRC
Temperature Range Operating Storage (Non-Operating)	[°C] [°C]	0 to +50 -20 to +60
RoHS Compliance		RoHS Compliance

## 2.2 Optical Characteristics

The optical characteristics are measured under stable conditions at 25°C (Room Temperature) :

Item	Symbol	Conditions	Min.	Typ.	Max.	Unit	Note
White Luminance ILED=23mA (Base Panel Only)		5 points average	255	300	-	cd/m2	1, 4, 5.
Viewing Angle	θR	Horizontal (Right) CR = 10 (Left)	85	89	-	degree	4, 9
	θL		85	89	-		
	ψH	Vertical (Upper) CR = 10 (Lower)	85	89	-		
	ψL		85	89	-		
Luminance Uniformity	δ5P	5 Points	-	-	1.25		1, 3, 4
Luminance Uniformity	δ13P	13 Points	-	-	1.6		2, 3, 4
Contrast Ratio	CR		-	700	-		4, 6
Cross talk	%				4		4, 7
Response Time	TRT	Rising + Falling	-	25	35		
Color / Chromaticity Coordinates	Red	Rx	CIE 1931	TBD	TBD	TBD	4
		Ry		TBD	TBD	TBD	
	Green	Gx		TBD	TBD	TBD	
		Gy		TBD	TBD	TBD	
	Blue	Bx		TBD	TBD	TBD	
		By		TBD	TBD	TBD	
	White	Wx		0.283	0.313	0.343	
		Wy		0.299	0.329	0.359	
NTSC	%		-	72	-		

**Note 1:** 5 points position (Ref: Active area)

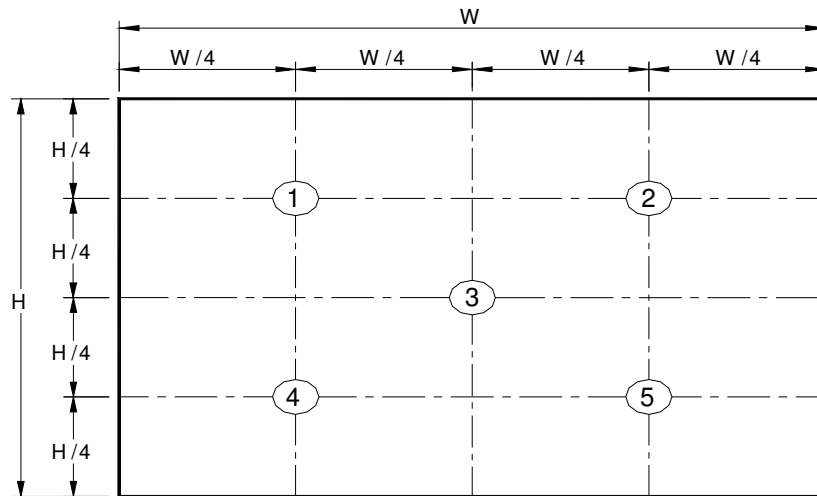

**Note 2:** 13 points position (Ref: Active area)

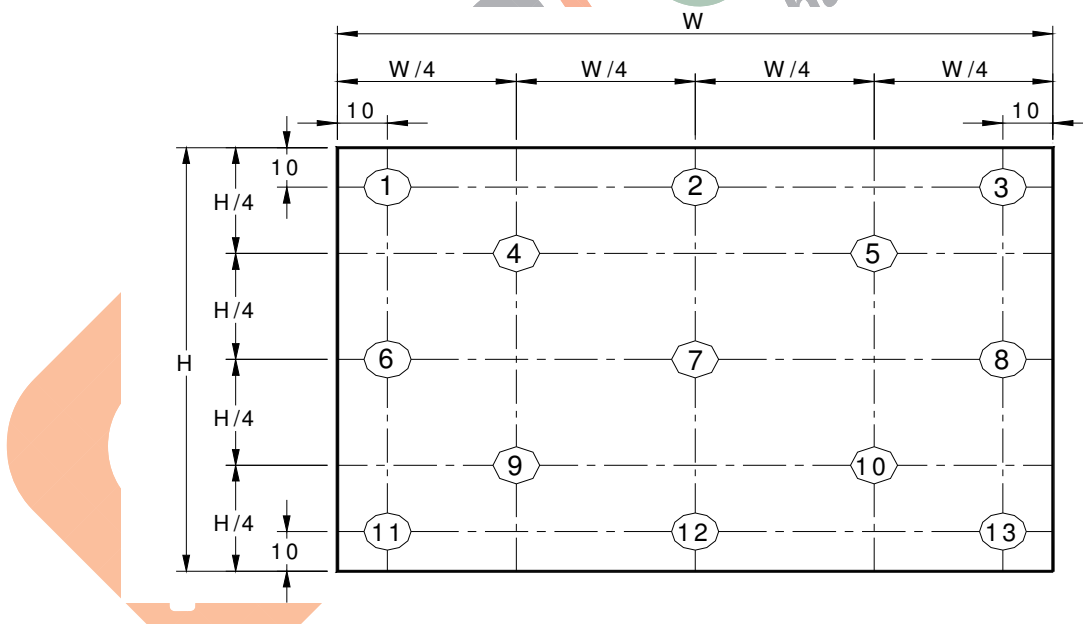

**Note 3:** The luminance uniformity of 5 or 13 points is defined by dividing the maximum luminance values by the minimum test point luminance

$$\delta_{w5} = \frac{\text{Maximum Brightness of five points}}{\text{Minimum Brightness of five points}}$$

$$\delta_{w13} = \frac{\text{Maximum Brightness of thirteen points}}{\text{Minimum Brightness of thirteen points}}$$

**Note 4:** Measurement method

The LCD module should be stabilized at given temperature for 30 minutes to avoid abrupt temperature change during measuring. In order to stabilize the luminance, the measurement should be executed after lighting

Backlight for 30 minutes in a stable, windless and dark room, and it should be measured in the center of screen.

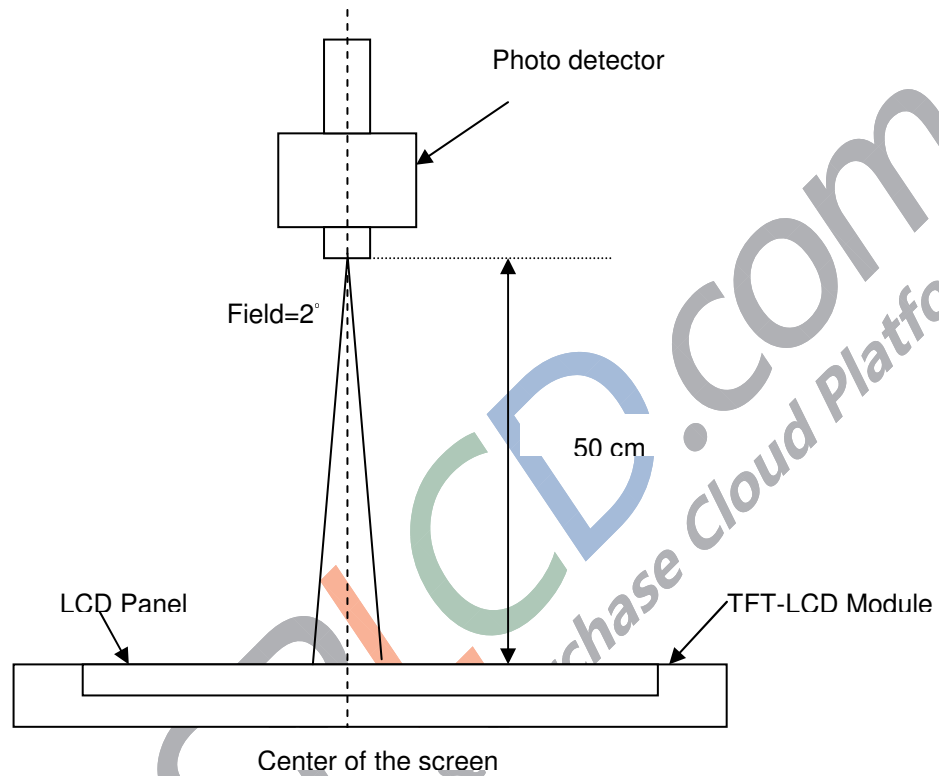

**Note 5** Definition of Average Luminance of White (YL):

Measure the luminance of gray level 63 at 5 points  $Y_L = [L(1) + L(2) + L(3) + L(4) + L(5)] / 5$

L(x) is corresponding to the luminance of the point X at Figure in Note (1).

**Note 6** Definition of contrast ratio:

Contrast ratio is calculated with the following formula.

$$\text{Contrast ratio (CR)} = \frac{\text{Brightness on the "White" state}}{\text{Brightness on the "Black" state}}$$

**Note 7** Definition of Cross Talk (CT)

$$CT = |Y_B - Y_A| / Y_A \times 100 (\%)$$

Where

$Y_A$  = Luminance of measured location without gray level 0 pattern (cd/m<sup>2</sup>)

$Y_B$  = Luminance of measured location with gray level 0 pattern (cd/m<sup>2</sup>)





**Note 8:** Definition of response time:

The output signals of BM-7 or equivalent are measured when the input signals are changed from "Black" to "White" (falling time) and from "White" to "Black" (rising time), respectively. The response time interval between the 10% and 90% of amplitudes. Refer to figure as below.

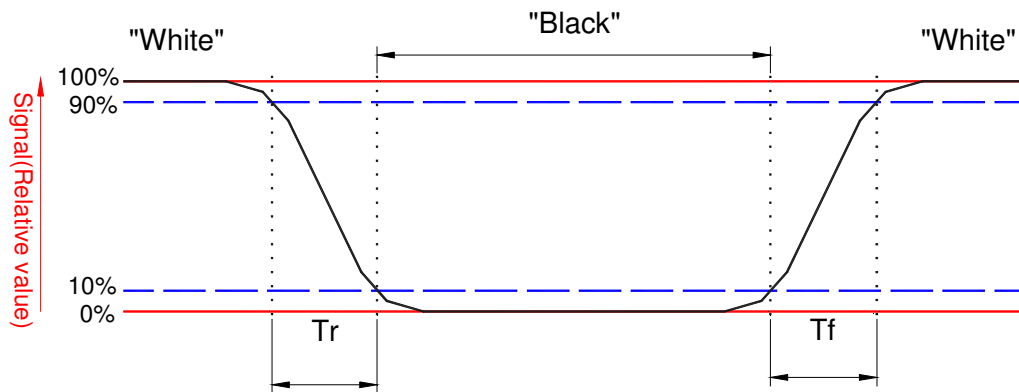

**Note 9.** Definition of viewing angle

Viewing angle is the measurement of contrast ratio  $\geq 10$ , at the screen center, over a 180° horizontal and 180° vertical range (off-normal viewing angles). The 180° viewing angle range is broken down as follows; 90° ( $\theta$ ) horizontal left and right and 90° ( $\Phi$ ) vertical, high (up) and low (down). The measurement direction is typically perpendicular to the display surface with the screen rotated about its center to develop the desired measurement viewing angle.

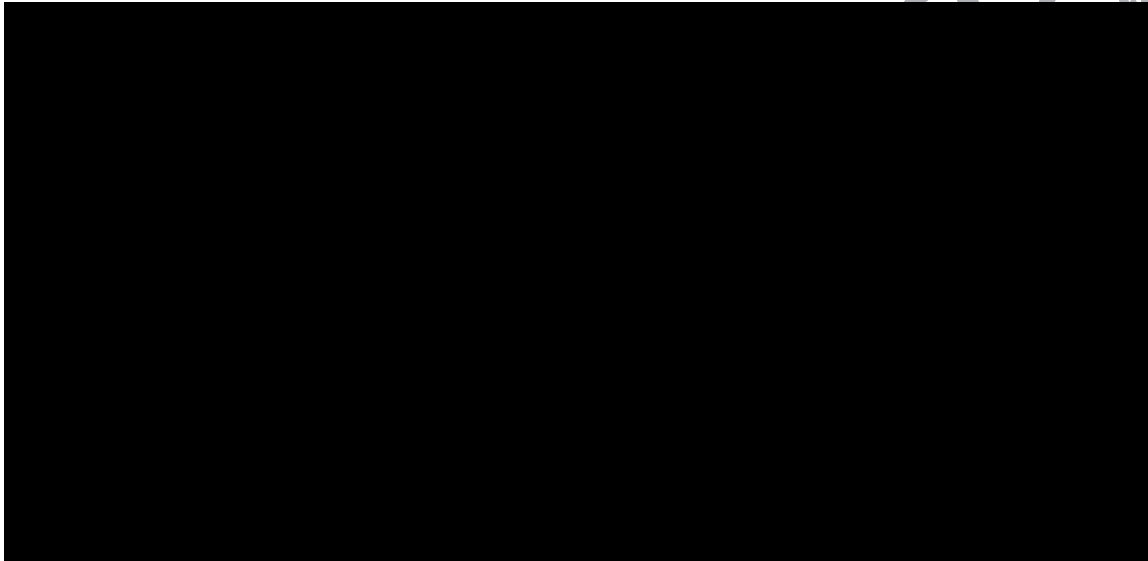

### 3. Functional Block Diagram

The following diagram shows the functional block of the 17.3 inches wide Color TFT/LCD 30 Pin

TBD



SPLCD.com  
Supply & Purchase Cloud Platform

## 4. Absolute Maximum Ratings

An absolute maximum rating of the module is as following:

### 4.1 Absolute Ratings of TFT LCD Module

Item	Symbol	Min	Max	Unit	Conditions
Logic/LCD Drive Voltage	Vin	-0.3	3.6	[Volt]	Note 1,2

### 4.2 Absolute Ratings of Environment

Item	Symbol	Min	Max	Unit	Conditions
Operating Temperature	TOP	0	+50	[°C]	Note 4
Operation Humidity	HOP	5	95	[%RH]	Note 4
Storage Temperature	TST	-20	+60	[°C]	Note 4
Storage Humidity	HST	10	90	[%RH]	Note 4

Note 1: At Ta (25°C )

Note 2: Permanent damage to the device may occur if exceed maximum values

Note 3: LED specification refer to section 5.2

Note 4: For quality performance, please refer to AUO IIS (Incoming Inspection Standard).

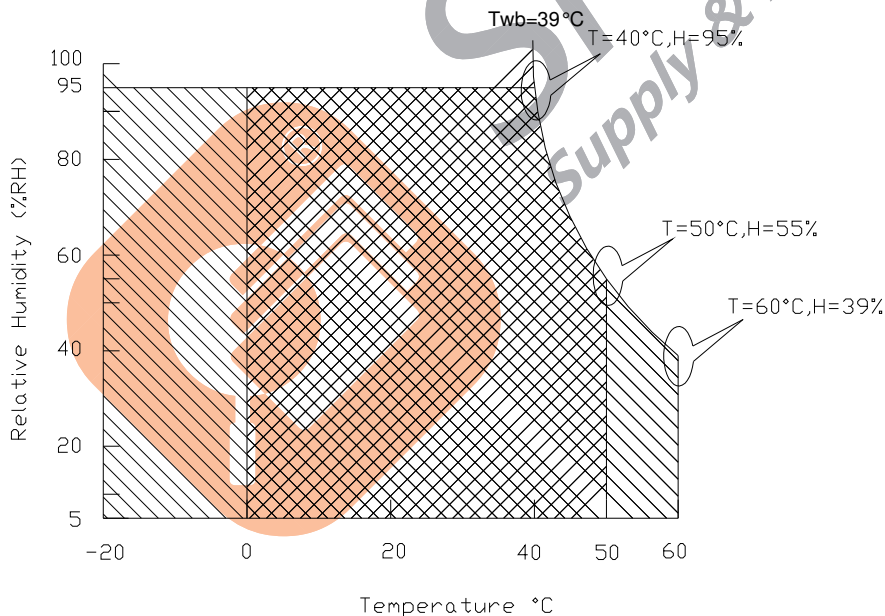

## 5. Electrical Characteristics

### 5.1 TFT LCD Module

#### 5.1.1 Power Specification

Input power specifications are as follows;

The power specification are measured under 25°C and frame frequency under 60Hz

Symble	Parameter	Min	Typ	Max	Units	Note
VDD	Logic/LCD Drive Voltage	3.0	3.3	3.6	[Volt]	
PDD	VDD Power	-	-	1.1	[Watt]	Note 1
IDD	IDD Current	-	-	366.7	[mA]	Note 1
IRush	Inrush Current	-	-	1500	[mA]	Note 2
VDDrp	Allowable Logic/LCD Drive Ripple Voltage	-	-	100	[mV] p-p	

Note 1 : Maximum Measurement Condition : White Pattern at 3.3V driving voltage. ( $P_{max}=V_{3.3} \times I_{white}$ )

Note 2 : Measure Condition

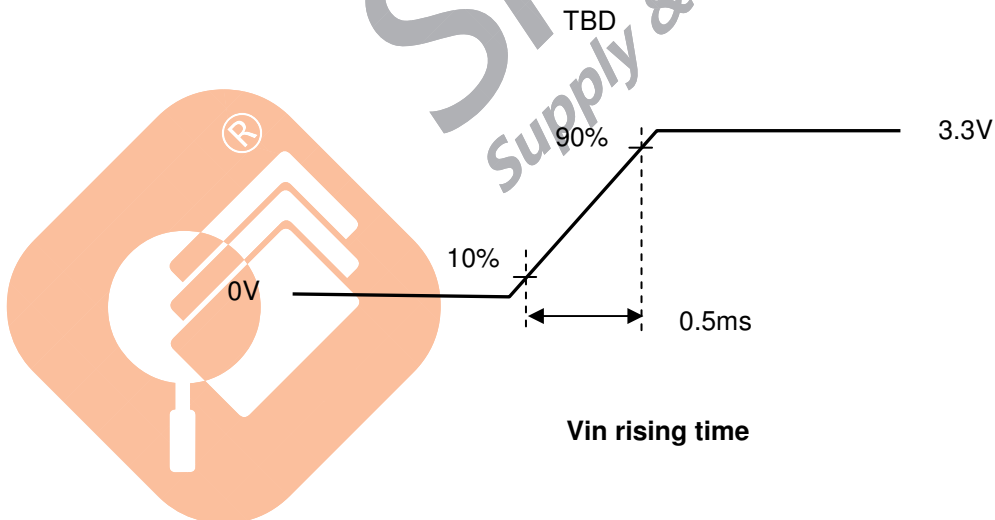

## 5.1.2 Signal Electrical Characteristics

Signal electrical characteristics are as follows;

### Display Port main link signal:

Differential pair VD+ , VD-  
Which is one Display port  
Main link

VCM of Display port  
Main link

$$V_{diff_{P-P}} = [(V_{D+}) - (V_{D-})] \times 2$$

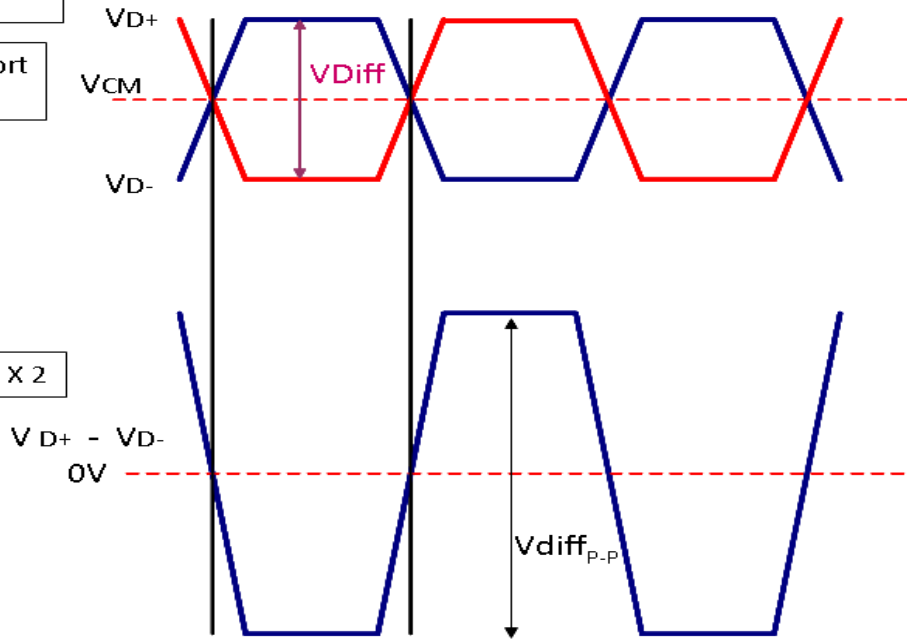

Display port main link					
		Min	Typ	Max	unit
VCM	RX input DC Common Mode Voltage		0		V
VDiff <sub>P-P</sub>	Peak-to-peak Voltage at a receiving Device	100		1320	mV

Follow as VESA display port standard V1.1a

### Display Port AUX\_CH signal:

Display port AUX_CH					
		Min	Typ	Max	unit
VCM	AUX DC Common Mode Voltage		0		V
VDiff <sub>P-P</sub>	AUX Peak-to-peak Voltage at a receiving Device	0.4	0.6	0.8	V

Follow as VESA display port standard V1.1a.

### Display Port VHPD signal:

Display port VHPD					
		Min	Typ	Max	unit
VHPD	HPD Voltage	2.9	--	3.6	V

Follow as VESA display port standard V1.3



SPLCD.com  
 Supply & Purchase cloud platform

## 5.2 Backlight Unit

### 5.2.1 LED characteristics

Parameter	Symbol	Min	Typ	Max	Units	Condition
Backlight Power Consumption	PLED	-	-	5.5	[Watt]	(Ta=25°C), Note 1
LED Life-Time	N/A	15,000	-	-	Hour	(Ta=25°C), Note 2

**Note 1:** Calculator value for reference  $P_{LED} = V_F$  (Normal Distribution) \*  $I_F$  (Normal Distribution) / Efficiency

**Note 2:** The LED life-time define as the estimated time to 50% degradation of initial luminous.

### 5.2.2 Backlight input signal characteristics

Parameter	Symbol	Min	Typ	Max	Units	Remark
LED Power Supply	VLED (Note 1)	6.0	12.0	21.0	[Volt]	Define as Connector Interface (Ta=25°C)
LED Enable Input High Level	VLED_EN	2.2	--	3.3	[Volt]	
LED Enable Input Low Level		--	--	0.6	[Volt]	
PWM Logic Input High Level	VPWM_EN	2.2	--	3.3	[Volt]	
PWM Logic Input Low Level		--	--	0.6	[Volt]	
PWM Input Frequency	FPWM	200	1K	10K	Hz	
PWM Duty Ratio	Duty	5	--	100	%	

**Note 1 :** Recommend system pull up/down resistor no bigger than 10kohm



## 6. Signal Interface Characteristic

### 6.1 Pixel Format Image

Following figure shows the relationship of the input signals and LCD pixel format.

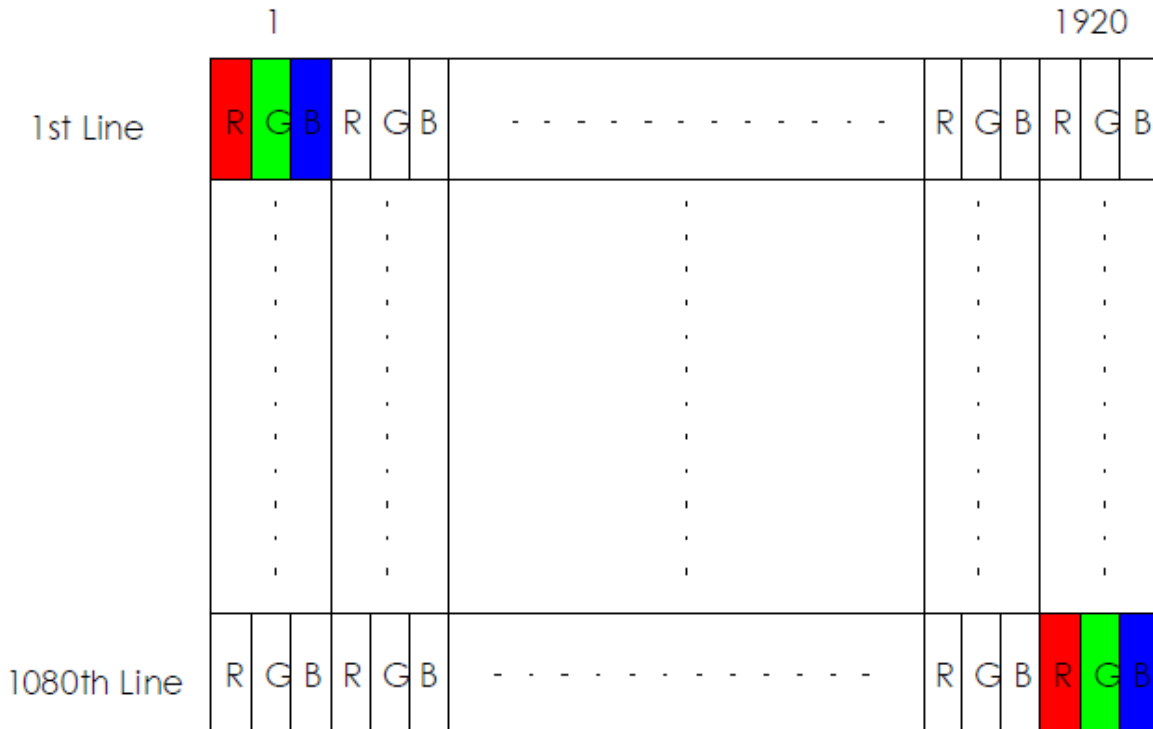

### 6.2 The Input Data Format

TBD

Note: Output signals from any system shall be low or High-impedance state when VDD is off.

## 6.3 Integration Interface Requirement

### 6.3.1 Connector Description

Physical interface is described as for the connector on module.

These connectors are capable of accommodating the following signals and will be following components.

Connector Name / Designation	For Signal Connector
Manufacturer	TBD
Type / Part Number	TBD
Mating Housing/Part Number	TBD

### 6.3.2 Pin Assignment

eDP lane is a differential signal technology for LCD interface and high speed data transfer device.

PIN NO	Symbol	Function
1	NC	NC
2	H_GND	High Speed Ground
3	Lane1_N	Complement Signal Link Lane 1
4	Lane1_P	True Signal Link Lane 1
5	H_GND	High Speed Ground
6	Lane0_N	Comp Signal Link Lane 0
7	Lane0_P	True Signal Link Lane 0
8	H_GND	High Speed Ground
9	AUX_CH_P	True Signal Auxiliary Ch.
10	AUX_CH_N	Comp Signal Auxiliary Ch.
11	H_GND	High Speed Ground
12	LCD_VCC	LCD logic and driver power
13	LCD_VCC	LCD logic and driver power
14	LCD_Self_Test	LCD Panel Self Test Enable
15	LCD_GND	LCD logic and driver ground
16	LCD_GND	LCD logic and driver ground
17	HPD	HPD signale pin
18	BL_GND	Backlight_ground
19	BL_GND	Backlight_ground
20	BL_GND	Backlight_ground
21	BL_GND	Backlight_ground
22	BL_Enable	Backlight On / Off

23	BL PWM DIM	System PWM signal Input
24	NC	NC
25	NC	NC
26	BL_PWR	Backlight power (6V~21V)
27	BL_PWR	Backlight power (6V~21V)
28	BL_PWR	Backlight power (6V~21V)
29	BL_PWR	Backlight power (6V~21V)
30	NC	NC

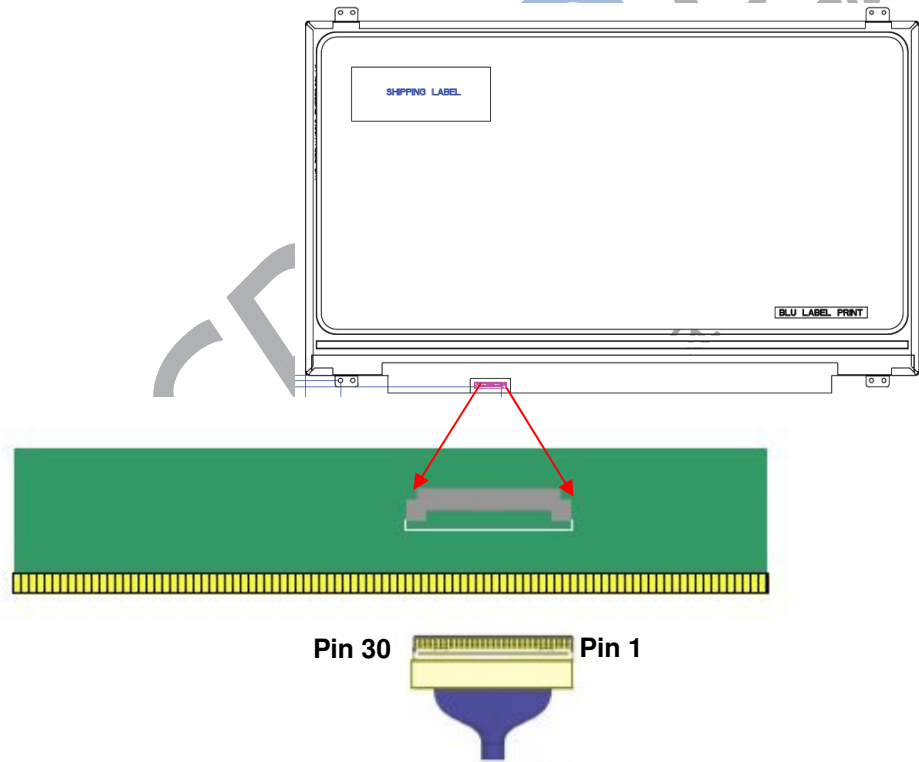

**Note1:** Start from right side.

**Note2:** Input signals shall be low or High-impedance state when VDD is off.  
Internal circuit of **eDP inputs** are as following.

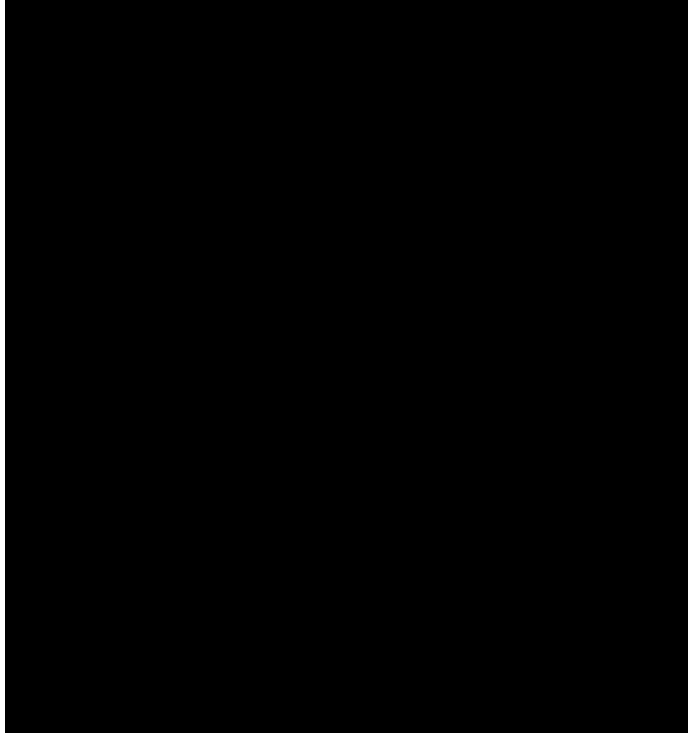

SP...D.com  
Supply & Purchase Cloud Platform

## 6.4 Interface Timing

### 6.4.1 Timing Characteristics

Basically, interface timings should match the 1920x1080 /60Hz manufacturing guide line timing.

Parameter	Symbol	Min.	Typ.	Max.	Unit
Frame Rate	-	-	TBD	-	Hz
Clock frequency	1/ T <sub>Clock</sub>	TBD	TBD	TBD	MHz
Vertical Section	Period	T <sub>V</sub>	TBD	TBD	T <sub>Line</sub>
	Active	T <sub>VD</sub>	1080		
	Blanking	T <sub>VB</sub>	TBD	TBD	
Horizontal Section	Period	T <sub>H</sub>	TBD	TBD	T <sub>Clock</sub>
	Active	T <sub>HD</sub>	1920		
	Blanking	T <sub>HB</sub>	TBD	TBD	

Note : 1. DE mode only

2. The maximum clock frequency = (1920+B)\*(1080+A)\*60 < 80MHz

## 6.5 Power ON/OFF Sequence

Power on/off sequence is as follows. Interface signals and LED on/off sequence are also shown in the chart. Signals from any system shall be Hi-Z state or low level when VDD is off

**Display Port panel power sequence:**

SPLCD.com  
Supply & Purchase Cloud Platform



**Display Port AUX\_CH transaction only:**

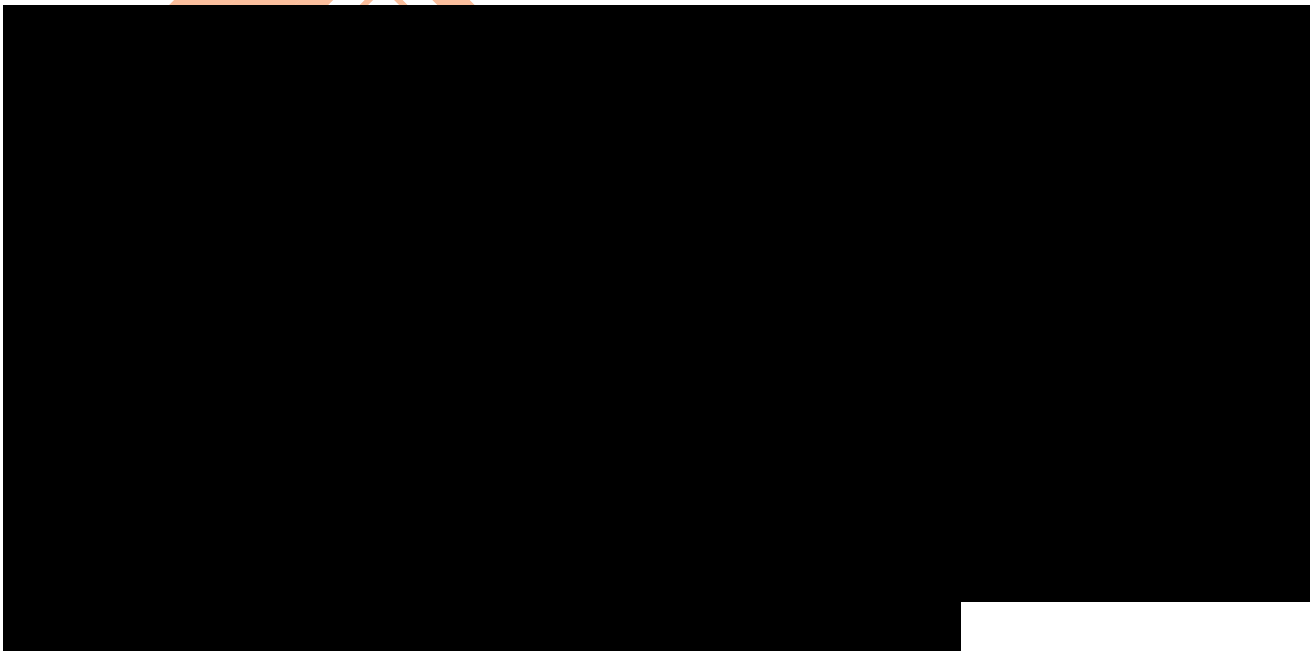

## Display Port Panel Power Sequence Timing Parameters

SPLCD.com  
Supply & Purchase Cloud Platform

**Note 1:** The sink must include the ability to generate black video autonomously. The sink must automatically enable black video under the following conditions:

- upon LCDVDD power on (with in T2 max)-when the "Novideostream\_Flag" (VB-ID Bit 3) is received from the source (at the end of T9).
- when no main link data, or invalid video data, is received from the source. Black video must be displayed within 64ms (typ) from the start of either condition. Video data can be deemed invalid based on MSA and timing information, for example.

**Note 2:** The sink may implement the ability to disable the black video function, as described in Note 1, above, for system development and debugging purpose.

**Note 3:** The sink must support AUX\_CH polling by the source immediately following LCDVDD power on without causing damage to the sink device (the source can re-try if the sink is not ready). The sink must be able to respond to an AUX\_CH transaction with the time specified within T3 max.

## Display Port panel B/L power sequence timing parameter:

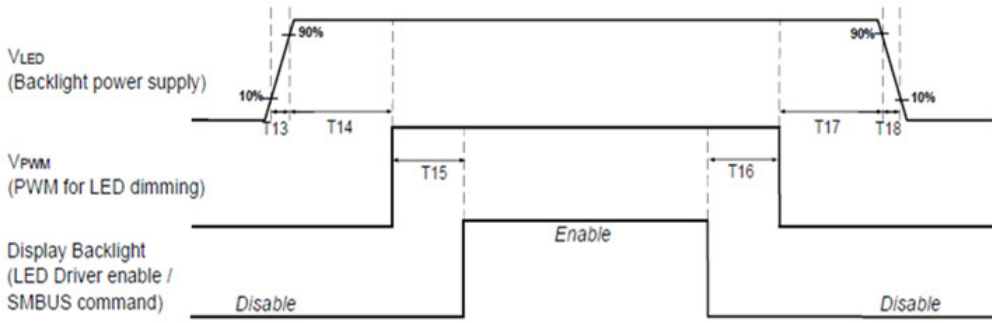

Note : When the adapter is hot plugged, the backlight power supply sequence is shown as below.

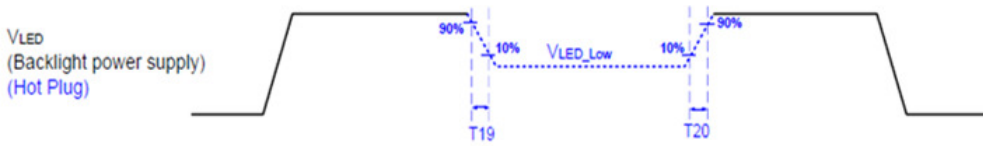

	Min (ms)	Max (ms)
T13	0.5	10
T14	10	-
T15	10	-
T16	10	-
T17	10	-
T18	0.5	10
T19	1*	-
T20	1*	-

Seamless change:  $T19/T20 = 5 \times T_{PWM}^*$

\* $T_{PWM} = 1/PWM \text{ Frequency}$



SPLC  
Supply & Purchase

## 7. Panel Reliability Test

### 7.1 Vibration Test

**Test Spec:**

- Test method: Non-Operation
- Acceleration: 1.5 G
- Frequency: 10 - 500Hz Random
- Sweep: 30 Minutes each Axis (X, Y, Z)

### 7.2 Shock Test

**Test Spec:**

- Test method: Non-Operation
- Acceleration: 220 G , Half sine wave
- Active time: 2 ms
- Pulse: X,Y,Z .one time for each side

### 7.3 Reliability Test

Items	Required Condition	Note
Temperature Humidity Bias	Ta= 40°C, 90%RH, 300h	
High Temperature Operation	Ta= 60°C, Dry, 300h	
Low Temperature Operation	Ta= 0°C, 300h	
High Temperature Storage	Ta= 60°C, 35%RH, 300h	
Low Temperature Storage	Ta= -20°C, 50%RH, 300h	
Thermal Shock Test	Ta=-20°C to 60°C, Duration at 30 min, 100 cycles	
ESD	Contact : ±8 KV Air : ±15 KV	Note 1

**Note1:** According to EN 61000-4-2 , ESD class B: Some performance degradation allowed. No data lost

. Self-recoverable. No hardware failures.

**Remark:** MTBF (Excluding the LED): 30,000 hours with a confidence level 90%



## 8. Mechanical Characteristics

### 8.1 LCM Outline Dimension

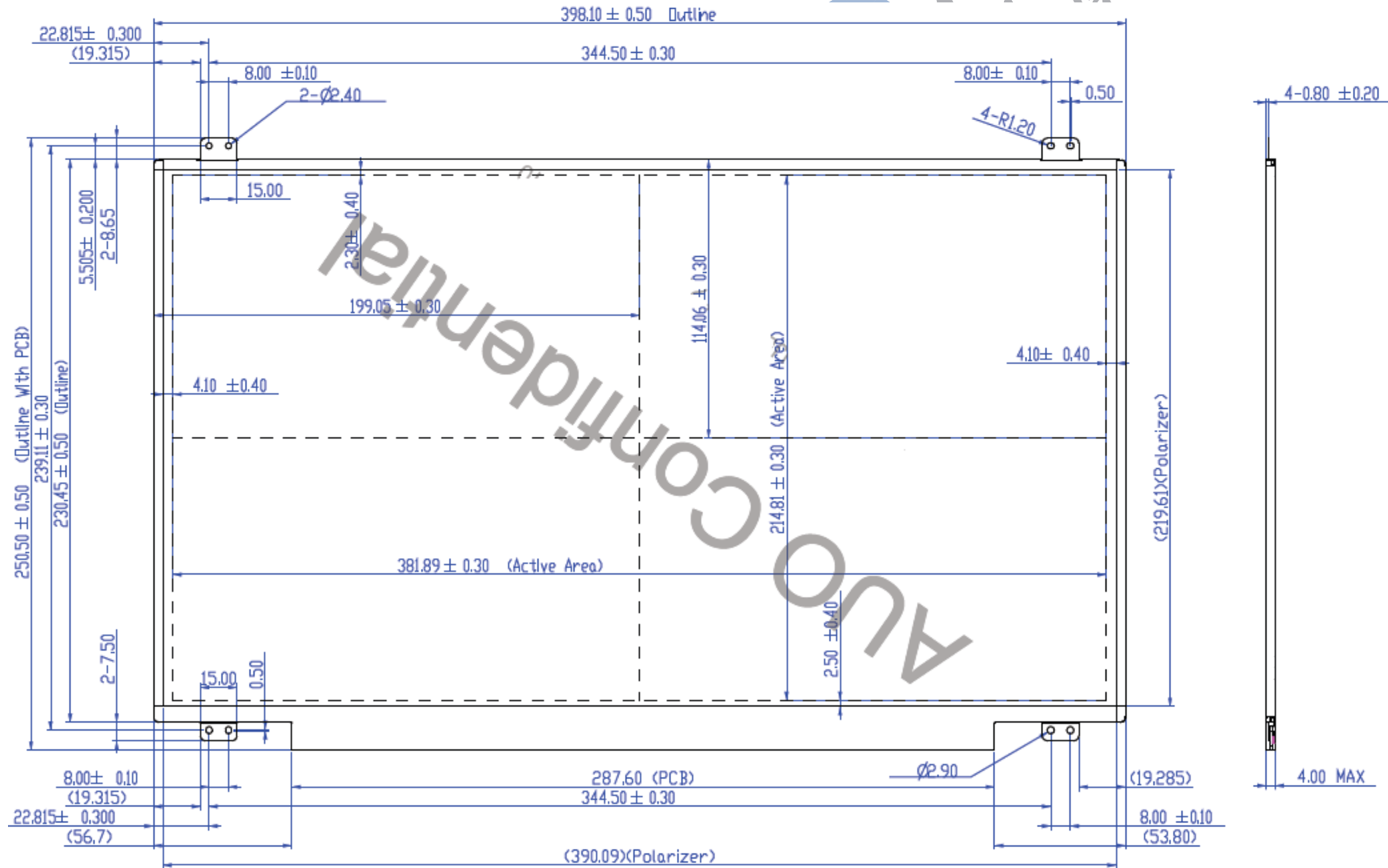

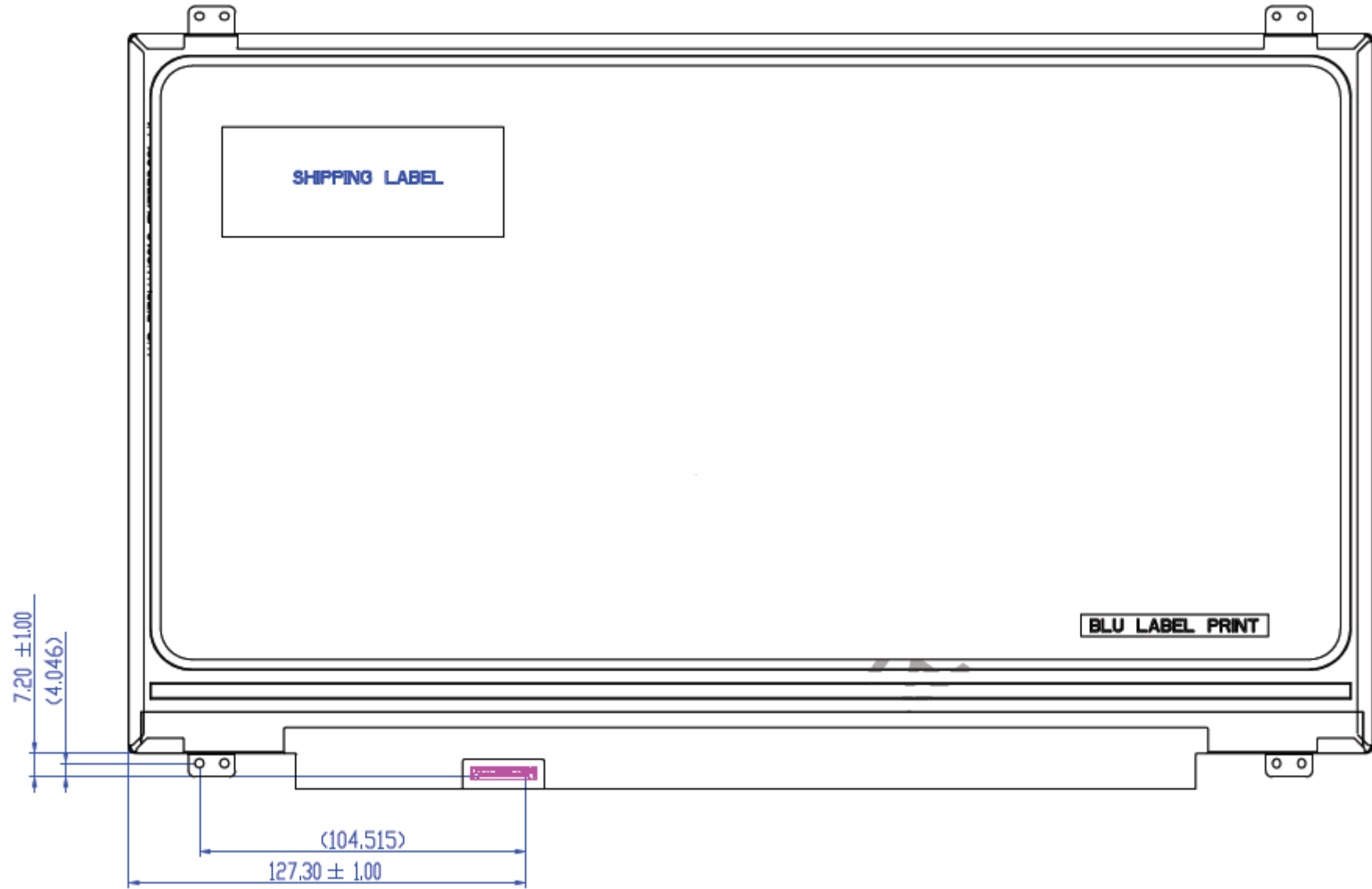

## 9. Shipping and Package

### 9.1 Shipping Label Format



### 9.2 Carton Package

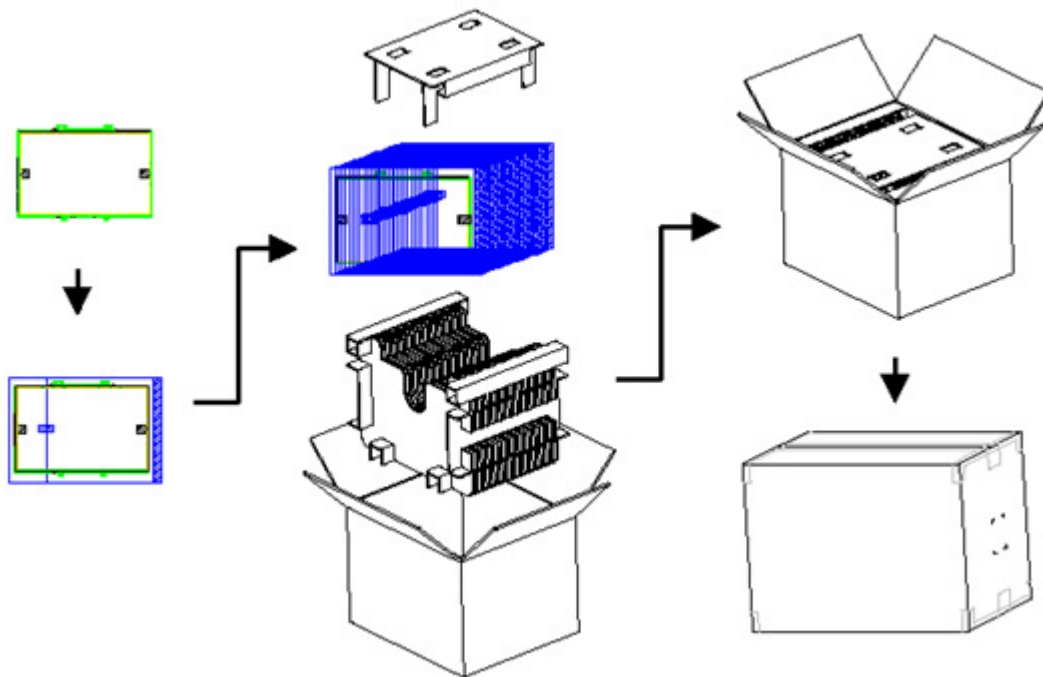

## 9.3 Shipping Package of Palletizing Sequence

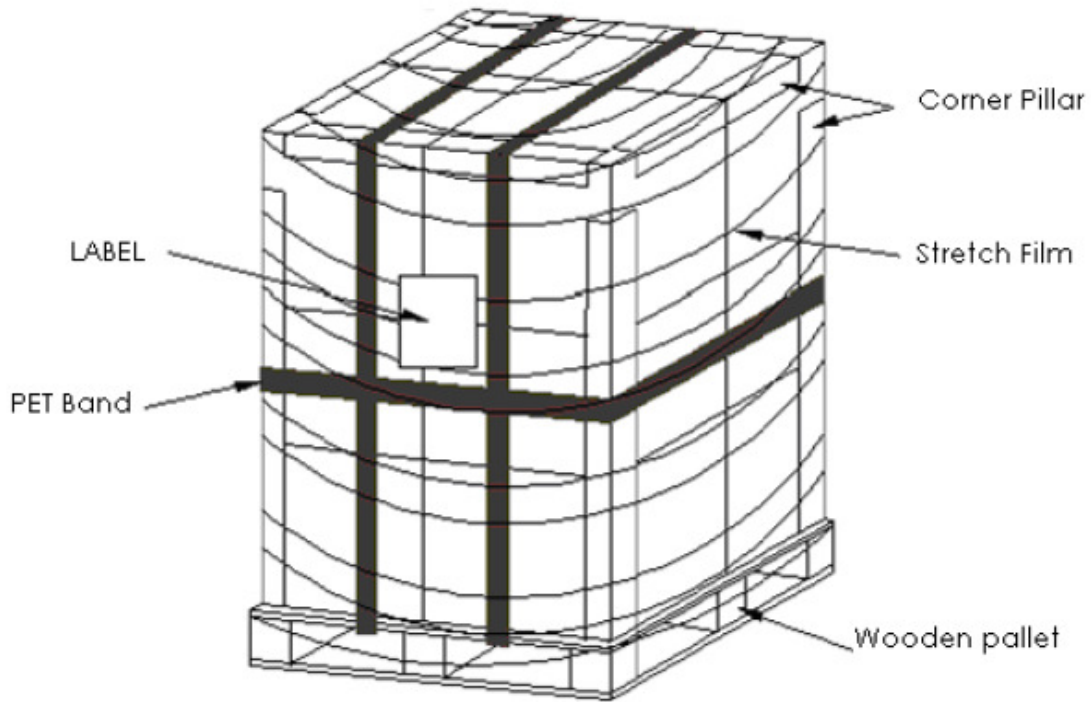

Supply

arm

## 10. Appendix: EDID Description

Address	FUNCTION	Value	Value	Value	Note
HEX		HEX	BIN	DEC	
00	Header	00	00000000	0	
01		FF	11111111	255	
02		FF	11111111	255	
03		FF	11111111	255	
04		FF	11111111	255	
05		FF	11111111	255	
06		FF	11111111	255	
07		00	00000000	0	
08	EISA Manuf. Code LSB	06	00000110	6	
09	Compressed ASCII	AF	10101111	175	
0A	Product Code	9D	10011101	157	
0B	hex, LSB first	10	00010000	16	
0C	32-bit ser #	00	00000000	0	
0D		00	00000000	0	
0E		00	00000000	0	
0F		00	00000000	0	
10	Week of manufacture	01	00000001	1	
11	Year of manufacture	19	00011001	25	
12	EDID Structure Ver.	01	00000001	1	
13	EDID revision #	04	00000100	4	
14	<b>Video input def.</b> ( <i>digital I/P, non-TMDS, CRGB</i> )	95	10010101	149	
15	<b>Max H image size</b> ( <i>rounded to cm</i> )	26	00100110	38	
16	<b>Max V image size</b> ( <i>rounded to cm</i> )	15	00010101	21	
17	<b>Display Gamma</b> ( <i>=(gamma*100)-100</i> )	78	01111000	120	
18	<b>Feature support</b> ( <i>no DPMS, Active OFF, RGB, tmg Blk#1</i> )	02	00000010	2	
19	Red/green low bits ( <b>Lower 2:2:2 bits</b> )	EC	11101100	236	
1A	Blue/white low bits ( <b>Lower 2:2:2 bits</b> )	05	00000101	5	
1B	Red x ( <b>Upper 8 bits</b> )	A3	10100011	163	
1C	Red y/ highER 8 bits	55	01010101	85	
1D	Green x	4E	01001110	78	
1E	Green y	9B	10011011	155	
1F	Blue x	26	00100110	38	
20	Blue y	0F	00001111	15	
21	White x	50	01010000	80	
22	White y	54	01010100	84	
23	Established timing 1	00	00000000	0	
24	Established timing 2	00	00000000	0	
25	Established timing 3	00	00000000	0	
26	Standard timing #1	01	00000001	1	
27		01	00000001	1	
28	Standard timing #2	01	00000001	1	
29		01	00000001	1	
2A	Standard timing #3	01	00000001	1	



# Product Specification

AU OPTRONICS CORPORATION

2B		01	00000001	1	
2C	Standard timing #4	01	00000001	1	
2D		01	00000001	1	
2E	Standard timing #5	01	00000001	1	
2F		01	00000001	1	
30	Standard timing #6	01	00000001	1	
31		01	00000001	1	
32	Standard timing #7	01	00000001	1	
33		01	00000001	1	
34	Standard timing #8	01	00000001	1	
35		01	00000001	1	
36	Pixel Clock/10000 LSB	14	00010100	20	
37	Pixel Clock/10000 USB	37	00110111	55	
38	Horz active <b>Lower 8bits</b>	80	10000000	128	
39	Horz blanking <b>Lower 8bits</b>	B8	10111000	184	
3A	HorzAct:HorzBlnk <b>Upper 4:4 bits</b>	70	01110000	112	
3B	Vertical Active <b>Lower 8bits</b>	38	00111000	56	
3C	Vertical Blanking <b>Lower 8bits</b>	24	00100100	36	
3D	Vert Act : Vertical Blanking <b>(upper 4:4 bit)</b>	40	01000000	64	
3E	HorzSync. Offset	10	00010000	16	
3F	HorzSync.Width	10	00010000	16	
40	VertSync.Offset : VertSync.Width	3E	00111110	62	
41	Horz&Vert Sync Offset/Width <b>Upper 2bits</b>	00	00000000	0	
42	Horizontal Image Size <b>Lower 8bits</b>	7D	01111101	125	
43	Vertical Image Size <b>Lower 8bits</b>	D6	11010110	214	
44	Horizontal & Vertical Image Size <b>(upper 4:4 bits)</b>	10	00010000	16	
45	Horizontal Border <i>(zero for internal LCD)</i>	00	00000000	0	
46	Vertical Border <i>(zero for internal LCD)</i>	00	00000000	0	
47	Signal <i>(non-intr, norm, no stero, sep sync, neg pol)</i>	18	00011000	24	
48	Pixel Clock/10,000 (LSB)	B8	10111000	184	40Hz frame rate
49	Pixel Clock/10,000 (MSB)	24	00100100	36	
4A	Horizontal Addressable Pixels, lower 8 bits	80	10000000	128	
4B	Horizontal Blanking Pixels, lower 8 bits	B8	10111000	184	
4C	H Pixels, upper nibble : H Blanking, upper nibble	70	01110000	112	
4D	Vertical Addressable Lines, lower 8 bits	38	00111000	56	
4E	Vertical Blanking Lines, lower 8 bits	24	00100100	36	
4F	V lines, upper nibble : V blanking, upper nibble	40	01000000	64	
50	Horizontal Front Porch, lower 8 bits	10	00010000	16	
51	Horizontal Sync Pulse, lower 8 bits	10	00010000	16	
52	V Front Porch, lower nibble : V Sync Pulse, lower nibble	3E	00111110	62	
53	VFP, 2 bits: VSP 2 bits: HFP 2 bits: HFP 2 bits	00	00000000	0	
54	Horizontal Image Size in mm, lower 8 bits	7D	01111101	125	
55	Vertical Image Size in mm, lower 8 bits	D6	11010110	214	
56	H Image Size, upper nibble : V Image Size, upper nibble	10	00010000	16	
57	Horizontal Border	00	00000000	0	
58	Vertical Border	00	00000000	0	
59	Bit Encode Sync Information	18	00011000	24	



# Product Specification

AU OPTRONICS CORPORATION

5A	DC	00	00000000	0	nVDPS Reserved 00	
5B	HTOTAL	00	00000000	0		
5C	HA	00	00000000	0		
5D	HBL	00	00000000	0		
5E	HFP	00	00000000	0		
5F	HFPe	00	00000000	0		
60	HBP	00	00000000	0		
61	HB	00	00000000	0		
62	HSO	00	00000000	0		
63	HS	00	00000000	0		
64	VTOTAL	00	00000000	0		
65	VA	00	00000000	0		
66	VBL	00	00000000	0		
67	VFP	00	00000000	0		
68	VBP	00	00000000	0		
69	VB	00	00000000	0		
6A	VSO	00	00000000	0		
6B	VS	00	00000000	0		
6C	Detail Timing Description #4	00	00000000	0		Header
6D	Flag	00	00000000	0		
6E	Reserved	00	00000000	0		
6F	For Brightness Table and Power Consumption	02	00000010	2		
70	Flag	00	00000000	0	Brightness Table	
71	PWM % [7:0] @ Step 0	10	00010000	16		
72	PWM % [7:0] @ Step 5	36	00110110	54		
73	PWM % [7:0] @ Step 10	FF	11111111	255		
74	Nits [7:0] @ Step 0	0F	00001111	15		
75	Nits [7:0] @ Step 5	3C	00111100	60		
76	Nits [7:0] @ Step 10	96	10010110	150	Power Consumption	
77	Panel Electronics Power @ 32x32 Chess Pattern =	16	00010110	22		
78	Backlight Power @ 60 nits =	15	00010101	21		
79	Backlight Power @ Step 10 =	36	00110110	54		
7A	Nits @ 100% PWM Duty =	96	10010110	150		
7B	Flag	20	00100000	32		
7C	Flag	20	00100000	32		
7D	Flag	20	00100000	32		
7E	Extension Flag	00	00000000	0		
7F	Checksum	A0	10100000	160		
<b>SUM</b>				<b>6656</b>		