



# Product Specification

AU OPTRONICS CORPORATION

(  ) Preliminary Specifications

(  ) Final Specifications

<b>Module</b>	<b>17.3”(17.25”) FHD 16:9 Color TFT-LCD with LED Backlight design</b>
<b>Model Name</b>	B173HW02 V1 (H/W:0A)
<b>Note</b> (  )	<b><i>LED Backlight with driving circuit design</i></b>

<b>Customer</b>	<b>Date</b>
<b>Checked &amp; Approved by</b>	<b>Date</b>
Note: This Specification is subject to change without notice.	

<b>Approved by</b>	<b>Date</b>
<b>Prepared by</b>	<b>Date</b>
<b>NBBU Marketing Division</b> <b>AU Optronics corporation</b>	



## Contents

<b>1. Handling Precautions</b> .....	<b>4</b>
<b>2. General Description</b> .....	<b>5</b>
2.1 General Specification .....	5
2.2 Optical Characteristics .....	6
<b>3. Functional Block Diagram</b> .....	<b>11</b>
<b>4. Absolute Maximum Ratings</b> .....	<b>12</b>
4.1 Absolute Ratings of TFT LCD Module .....	12
4.2 Absolute Ratings of Environment .....	12
<b>5. Electrical Characteristics</b> .....	<b>13</b>
5.1 TFT LCD Module .....	13
5.2 Backlight Unit .....	15
<b>6. Signal Interface Characteristic</b> .....	<b>16</b>
6.1 Pixel Format Image .....	16
6.2 The Input Data Format .....	17
6.3 Integration Interface Requirement.....	18
6.4 Interface Timing.....	21
<b>7. Panel Reliability Test</b> .....	<b>23</b>
7.1 Vibration Test.....	23
7.2 Shock Test.....	23
7.3 Reliability Test .....	23
<b>8. Mechanical Characteristics</b> .....	<b>24</b>
8.1 LCM Outline Dimension .....	24
8.2 Screw Hole Depth and Center Position .....	26
<b>9. Shipping and Package</b> .....	<b>27</b>
9.1 Shipping Label Format .....	27
9.2 Carton Package .....	27
9.3 Shipping Package of Palletizing Sequence .....	28
<b>10. Appendix: EDID Description</b> .....	<b>29</b>



# Product Specification

AU OPTRONICS CORPORATION

## Record of Revision

Version and Date	Page	Old description	New Description	Remark
0.1 2011/4/27	All	Preliminary Edition		

## 1. Handling Precautions

- 1) Since front polarizer is easily damaged, pay attention not to scratch it.
- 2) Be sure to turn off power supply when inserting or disconnecting from input connector.
- 3) Wipe off water drop immediately. Long contact with water may cause discoloration or spots.
- 4) When the panel surface is soiled, wipe it with absorbent cotton or other soft cloth.
- 5) Since the panel is made of glass, it may break or crack if dropped or bumped on hard surface.
- 6) Since CMOS LSI is used in this module, take care of static electricity and insure human earth when handling.
- 7) Do not open nor modify the Module Assembly.
- 8) Do not press the reflector sheet at the back of the module to any directions.
- 9) At the insertion or removal of the Signal Interface Connector, be sure not to rotate nor tilt the Interface Connector of the TFT Module.
- 11) After installation of the TFT Module into an enclosure (Notebook PC Bezel, for example), do not twist nor bend the TFT Module even momentary. At designing the enclosure, it should be taken into consideration that no bending/twisting forces are applied to the TFT Module from outside. Otherwise the TFT Module may be damaged.
- 12) Small amount of materials having no flammability grade is used in the LCD module. The LCD module should be supplied by power complied with requirements of Limited Power Source (IEC60950 or UL1950), or be applied exemption.
- 13) Disconnecting power supply before handling LCD modules, it can prevent electric shock, DO NOT TOUCH the electrode parts, cables, connectors and LED circuit part of TFT module that a LED light bar build in as a light source of back light unit. It can prevent electrostatic breakdown.



## 2. General Description

B173HW02 V1 is a Color Active Matrix Liquid Crystal Display composed of a TFT LCD panel, a driver circuit, and LED backlight system. The screen format is intended to support the FHD 16:9 1920(H) x 1080(V) screen and 262k colors (RGB 6-bits data driver) with LED backlight driving circuit. All input signals are LVDS interface compatible.

B173HW02 V1 is designed for a display unit of notebook style personal computer and industrial machine.

### 2.1 General Specification

The following items are characteristics summary on the table at 25 °C condition:

Items	Unit	Specifications			
Screen Diagonal	[mm]	17.3W”(17.25)			
Active Area	[mm]	381.888 X 214.812			
Pixels H x V		1920x3(RGB) x1080			
Pixel Pitch	[mm]	0.1989X0.1989			
Pixel Format		R.G.B. Vertical Stripe			
Display Mode		Normally White			
White Luminance (ILED=20mA) <b>(Note: ILED is LED current)</b>	[cd/m <sup>2</sup> ]	300 typ. (5 points average) 255 min. (5 points average)			
Luminance Uniformity		1.25 max. (5 points) / 1.35 max. (13 points)			
Contrast Ratio		<b>400</b> typ			
Response Time	[ms]	8 typ / 16 Max			
Nominal Input Voltage VDD	[Volt]	+3.3 typ.			
Power Consumption	[Watt]	9.0 max. (Include Logic and Blu power)			
Weight	[Grams]	590 max.			
Physical Size Include bracket	[mm]		Min.	Typ.	Max.
		Length	397.6	398.1	398.6
		Width	232.3	232.8	233.3
		Thickness	---	---	6.0
Electrical Interface		2 channel LVDS			
Glass Thickness	[mm]	0.5			
Surface Treatment		<b>Anti-Glare</b>			
Support Color		262K colors ( RGB 6-bit )			
Temperature Range Operating Storage (Non-Operating)	[°C] [°C]	0 to +50 -20 to +60			
RoHS Compliance		RoHS Compliance			



## 2.2 Optical Characteristics

The optical characteristics are measured under stable conditions at 25°C (Room Temperature) :

Item	Symbol	Conditions	Min.	Typ.	Max.	Unit	Note	
White Luminance ILED=20mA		5 points average	255	300	---	cd/m <sup>2</sup>	1, 4, 5.	
Viewing Angle	$\theta_R$ $\theta_L$	Horizontal (Right) CR = 10 (Left)	<b>60</b> <b>60</b>	<b>70</b> <b>70</b>	---	degree	4, 9	
	$\psi_H$ $\psi_L$	Vertical (Upper) CR = 10 (Lower)	<b>45</b> <b>50</b>	<b>60</b> <b>60</b>	---			
Luminance Uniformity	$\delta_{5P}$	5 Points	---	---	1.25		1, 3, 4	
Luminance Uniformity	$\delta_{13P}$	13 Points	---	---	1.42		2, 3, 4	
Contrast Ratio	CR		<b>300</b>	<b>400</b>	---		4, 6	
Cross talk	%		---	---	4		4, 7	
Response Time	$T_{RT}$	Rising + Falling	---	8	16	msec	4, 8	
Color / Chromaticity Coordinates	Red	Rx	CIE 1931	TBD	TBD	TBD	---	4
		Ry		TBD	TBD	TBD		
	Green	Gx		TBD	TBD	TBD		
		Gy		TBD	TBD	TBD		
	Blue	Bx		TBD	TBD	TBD		
		By		TBD	TBD	TBD		
	White	Wx		0.283	0.313	0.342		
		Wy		0.299	0.329	0.359		
NTSC	%		---	72	---			

**Note 1:** 5 points position (Ref: Active area)

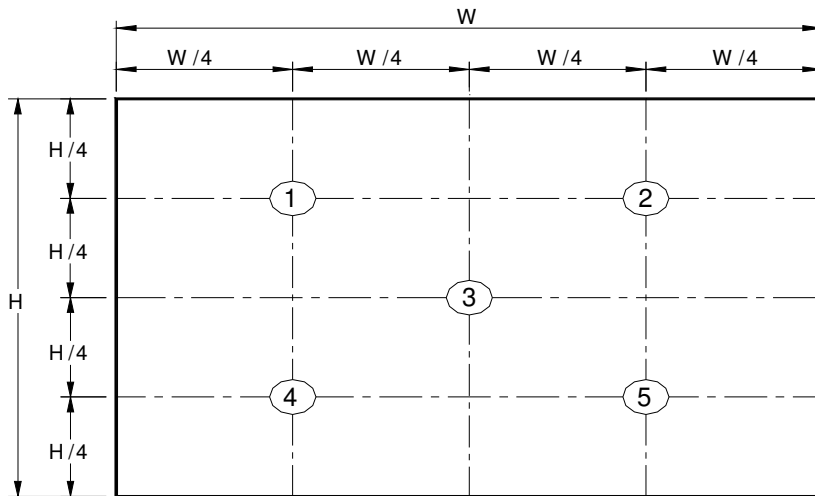

**Note 2:** 13 points position (Ref: Active area)

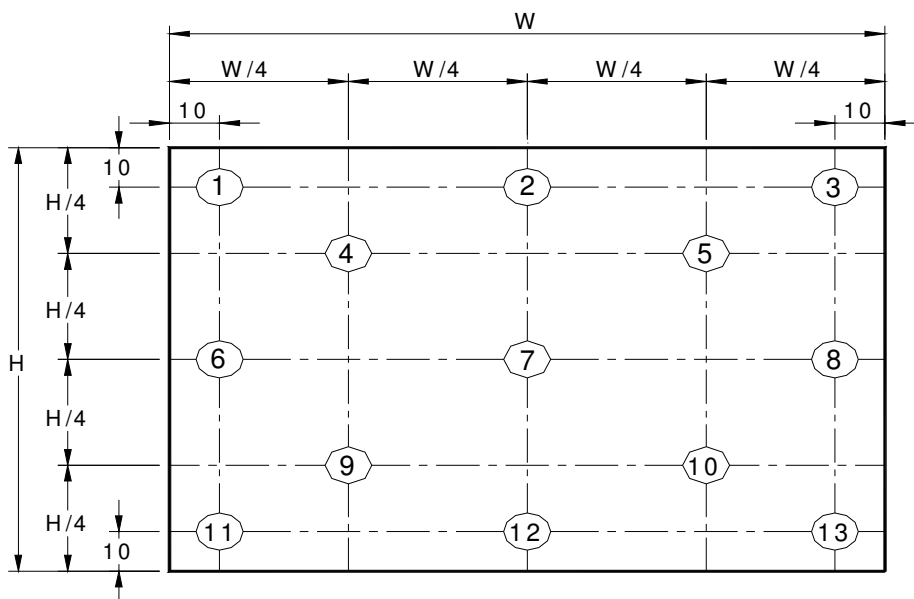

**Note 3:** The luminance uniformity of 5 or 13 points is defined by dividing the maximum luminance values by the minimum test point luminance

$$\delta_{w5} = \frac{\text{Maximum Brightness of five points}}{\text{Minimum Brightness of five points}}$$

$$\delta_{w13} = \frac{\text{Maximum Brightness of thirteen points}}{\text{Minimum Brightness of thirteen points}}$$

**Note 4:** Measurement method

The LCD module should be stabilized at given temperature for 30 minutes to avoid abrupt temperature change during measuring. In order to stabilize the luminance, the measurement should be executed after lighting Backlight

for 30 minutes in a stable, windless and dark room, and it should be measured in the center of screen.

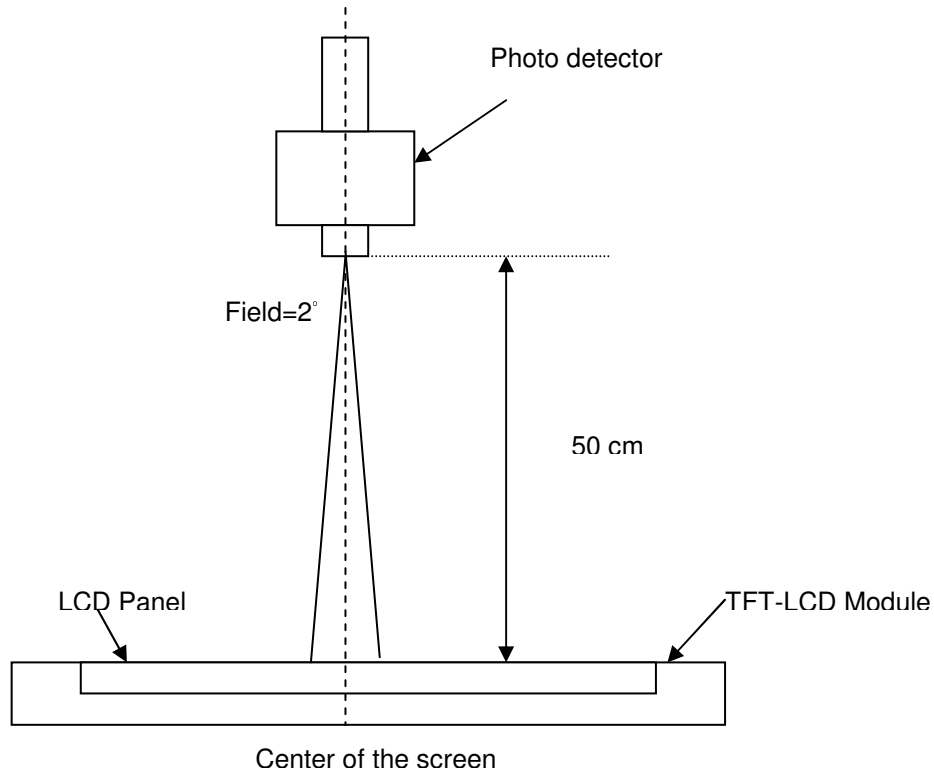

**Note 5 :** Definition of Average Luminance of White ( $Y_L$ ):

Measure the luminance of gray level 63 at 5 points ·  $Y_L = [L(1) + L(2) + L(3) + L(4) + L(5)] / 5$

$L(x)$  is corresponding to the luminance of the point X at Figure in Note (1).

**Note 6 :** Definition of contrast ratio:

Contrast ratio is calculated with the following formula.

$$\text{Contrast ratio (CR)} = \frac{\text{Brightness on the "White" state}}{\text{Brightness on the "Black" state}}$$

**Note 7 :** Definition of Cross Talk (CT)

$$CT = |Y_B - Y_A| / Y_A \times 100 (\%)$$

Where

$Y_A$  = Luminance of measured location without gray level 0 pattern ( $\text{cd}/\text{m}^2$ )

$Y_B$  = Luminance of measured location with gray level 0 pattern ( $\text{cd}/\text{m}^2$ )



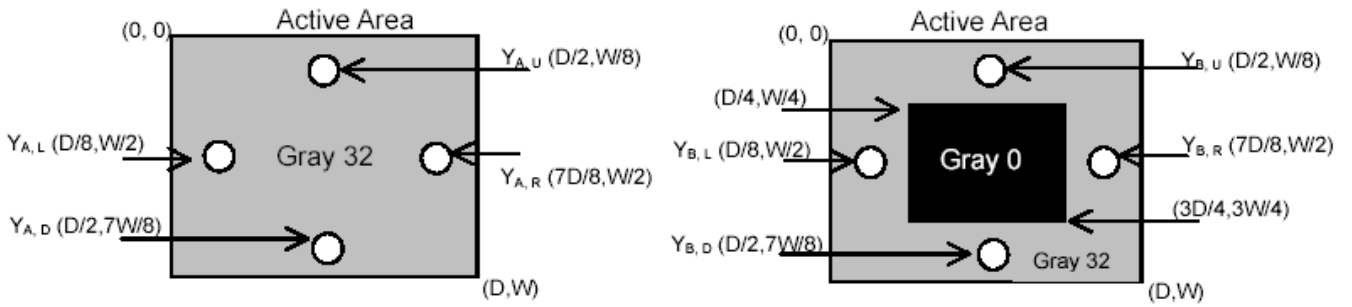

**Note 8:** Definition of response time:

The output signals of BM-7 or equivalent are measured when the input signals are changed from "Black" to "White" (falling time) and from "White" to "Black" (rising time), respectively. The response time interval between the 10% and 90% of amplitudes. Refer to figure as below.

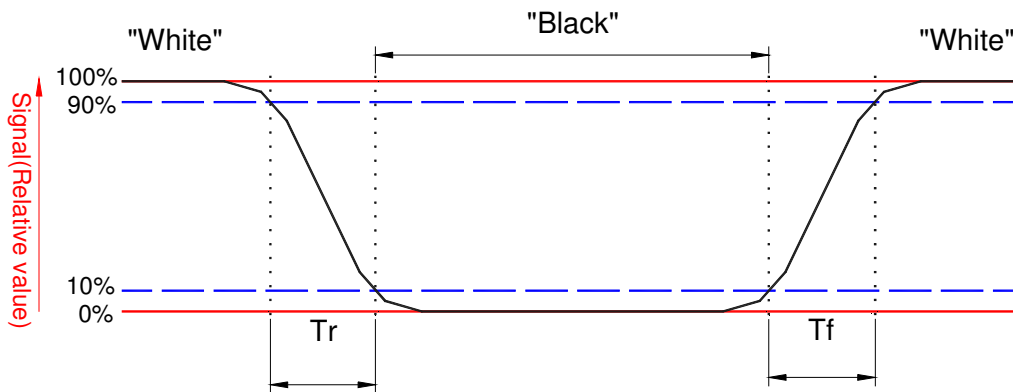

**Note 9.** Definition of viewing angle

Viewing angle is the measurement of contrast ratio  $\geq 10$ , at the screen center, over a  $180^\circ$  horizontal and  $180^\circ$  vertical range (off-normal viewing angles). The  $180^\circ$  viewing angle range is broken down as follows;  $90^\circ$  ( $\theta$ ) horizontal left and right and  $90^\circ$  ( $\Phi$ ) vertical, high (up) and low (down). The measurement direction is typically perpendicular to the display surface with the screen rotated about its center to develop the desired measurement viewing angle.

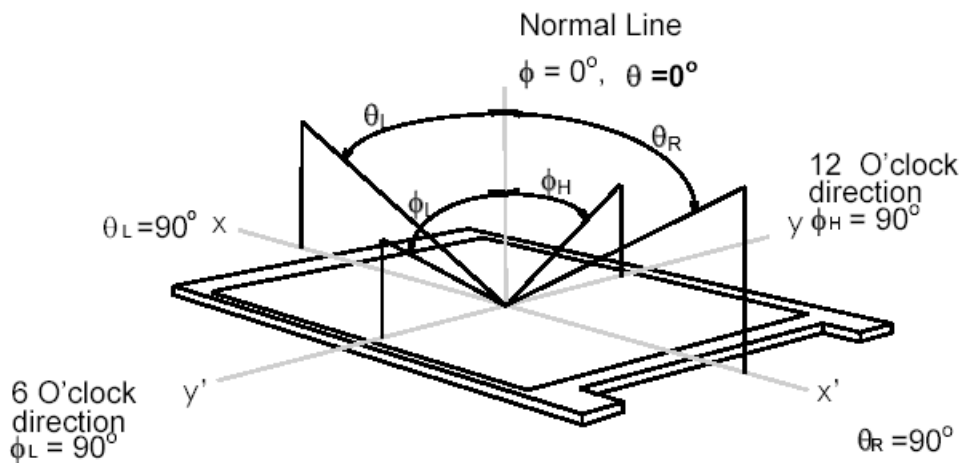

## 3. Functional Block Diagram

The following diagram shows the functional block of the 17.3 inches wide Color TFT/LCD 40 Pin two channel Module

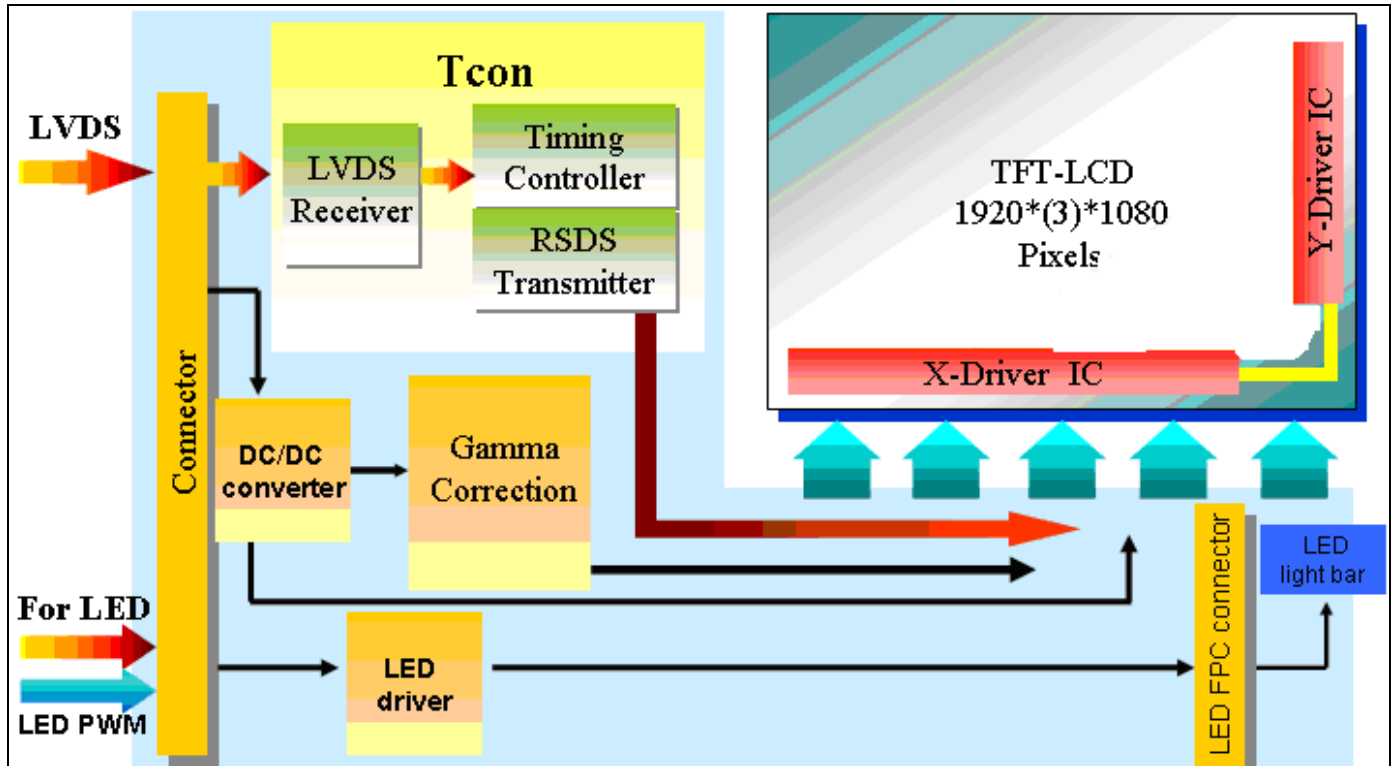

## 4. Absolute Maximum Ratings

An absolute maximum rating of the module is as following:

### 4.1 Absolute Ratings of TFT LCD Module

Item	Symbol	Min	Max	Unit	Conditions
Logic/LCD Drive Voltage	Vin	-0.3	+4.0	[Volt]	Note 1,2

### 4.2 Absolute Ratings of Environment

Item	Symbol	Min	Max	Unit	Conditions
Operating Temperature	TOP	0	+50	[°C]	Note 4
Operation Humidity	HOP	5	95	[%RH]	Note 4
Storage Temperature	TST	-20	+60	[°C]	Note 4
Storage Humidity	HST	5	95	[%RH]	Note 4

Note 1: At Ta (25°C )

Note 2: Permanent damage to the device may occur if exceed maximum values

Note 3: LED specification refer to section 5.2

Note 4: For quality performance, please refer to AUO IIS (Incoming Inspection Standard).

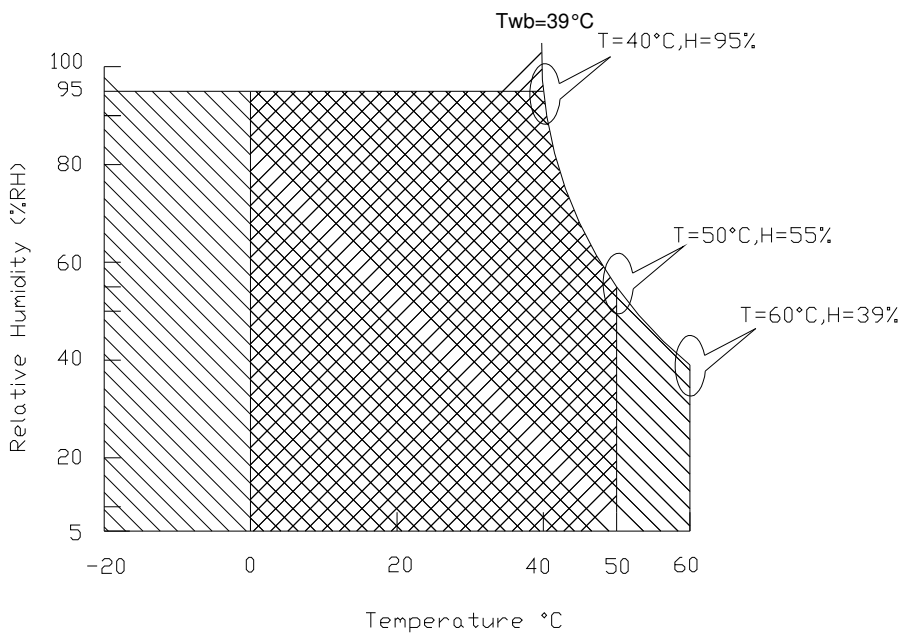

Operating Range 

Storage Range

 + 

## 5. Electrical Characteristics

### 5.1 TFT LCD Module

#### 5.1.1 Power Specification

Input power specifications are as follows;

The power specification are measured under 25°C and frame frequency under 60Hz

Symble	Parameter	Min	Typ	Max	Units	Note
VDD	Logic/LCD Drive Voltage	3.0	3.3	3.6	[Volt]	
PDD	VDD Power	-	-	2	[Watt]	Note 1
IDD	IDD Current	-	350	600	[mA]	Note 1
IRush	Inrush Current	-	-	2000	[mA]	Note 2
VDDrp	Allowable Logic/LCD Drive Ripple Voltage	-	-	100	[mV] p-p	

Note 1 : Maximum Measurement Condition : Black Pattern at 3.3V driving voltage. ( $P_{max}=V_{3.3} \times I_{black}$ )

Note 2 : Measure Condition

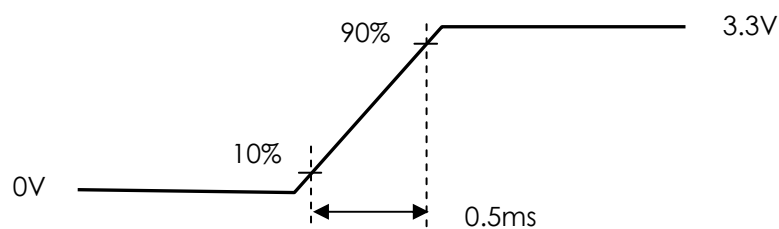
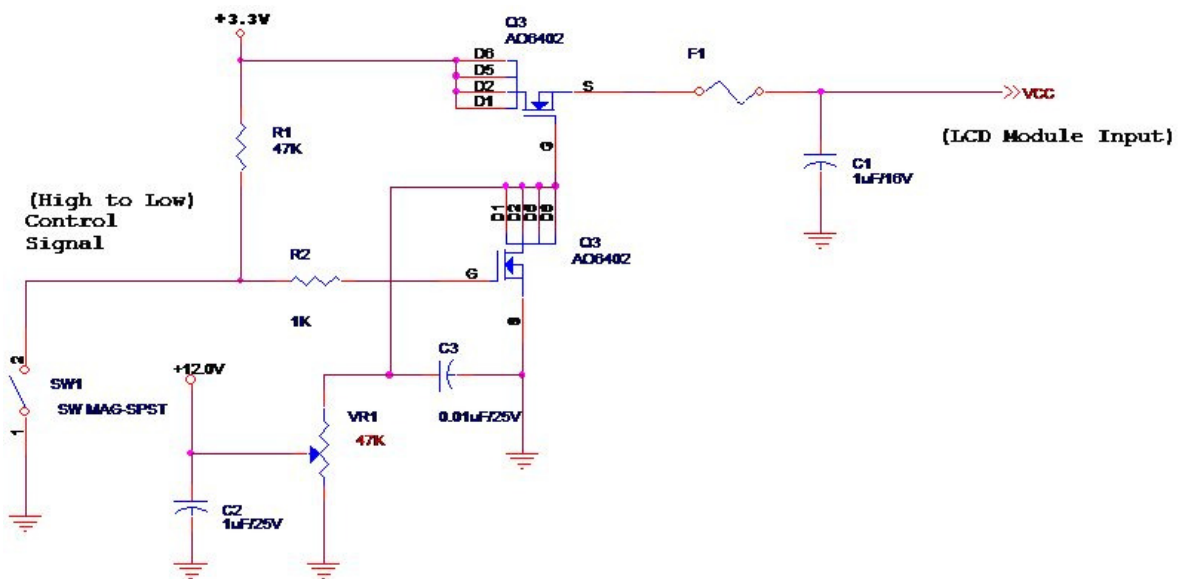

Vin rising time

## 5.1.2 Signal Electrical Characteristics

Input signals shall be low or High-impedance state when VDD is off.

Signal electrical characteristics are as follows;

Parameter	Condition	Min	Max	Unit
$V_{th}$	Differential Input High Threshold ( $V_{cm}=+1.2V$ )	---	100	[mV]
$V_{tl}$	Differential Input Low Threshold ( $V_{cm}=+1.2V$ )	-100	---	[mV]
$V_{ID}$	Differential Input Voltage	100	600	[mV]
$V_{cm}$	Differential Input Common Mode Voltage	1.125	1.375	[V]

Note: LVDS Signal Waveform

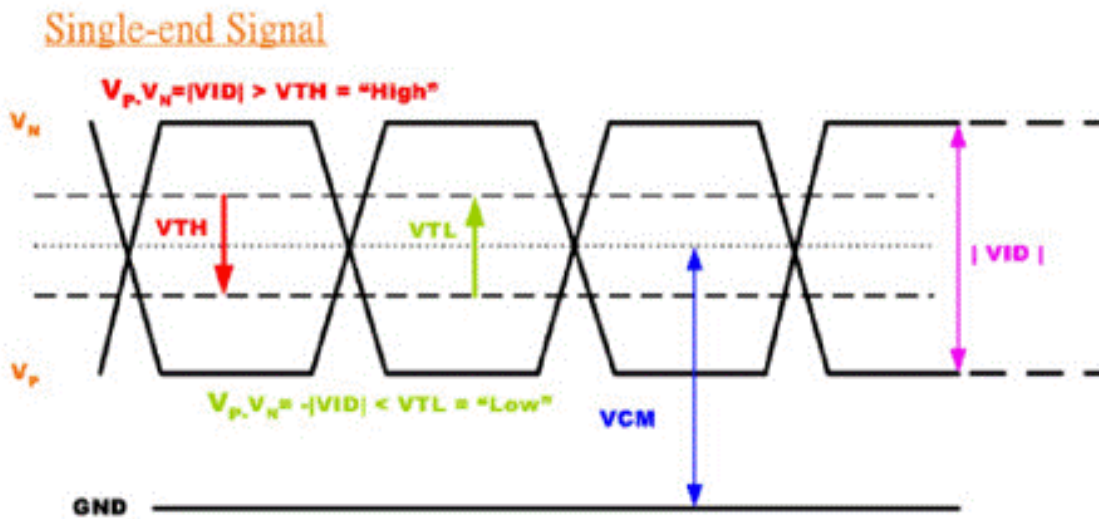

## 5.2 Backlight Unit

### 5.2.1 LED characteristics

Parameter	Symbol	Min	Typ	Max	Units	Condition
Backlight Power Consumption	PLED	-	-	7	[Watt]	(Ta=25°C), Note 1. Vin=12V
LED Life-Time	N/A	10,000	-	-	Hour	(Ta=25°C), Note 2 If=20 mA

**Note 1:** Calculator value for reference  $P_{LED} = V_F$  (Normal Distribution) \*  $I_F$  (Normal Distribution) / Efficiency

**Note 2:** The LED life-time define as the estimated time to 50% degradation of initial luminous.

### 5.2.2 Backlight input signal characteristics

Parameter	Symbol	Min	Typ	Max	Units	Remark
LED Power Supply	VLED	<b>7.0</b>	12.0	21.0	[Volt]	Define as Connector Interface (Ta=25°C)
LED Enable Input High Level	VLED_EN	2.5	-	5.5	[Volt]	
LED Enable Input Low Level		-	-	0.8	[Volt]	
PWM Logic Input High Level	VPWM_EN	2.5	-	5.5	[Volt]	
PWM Logic Input Low Level		-	-	0.8	[Volt]	
PWM Input Frequency	FPWM	100	<b>1K</b>	20K	Hz	
PWM Duty Ratio	Duty	5	--	100	%	

## 6. Signal Interface Characteristic

### 6.1 Pixel Format Image

Following figure shows the relationship of the input signals and LCD pixel format.

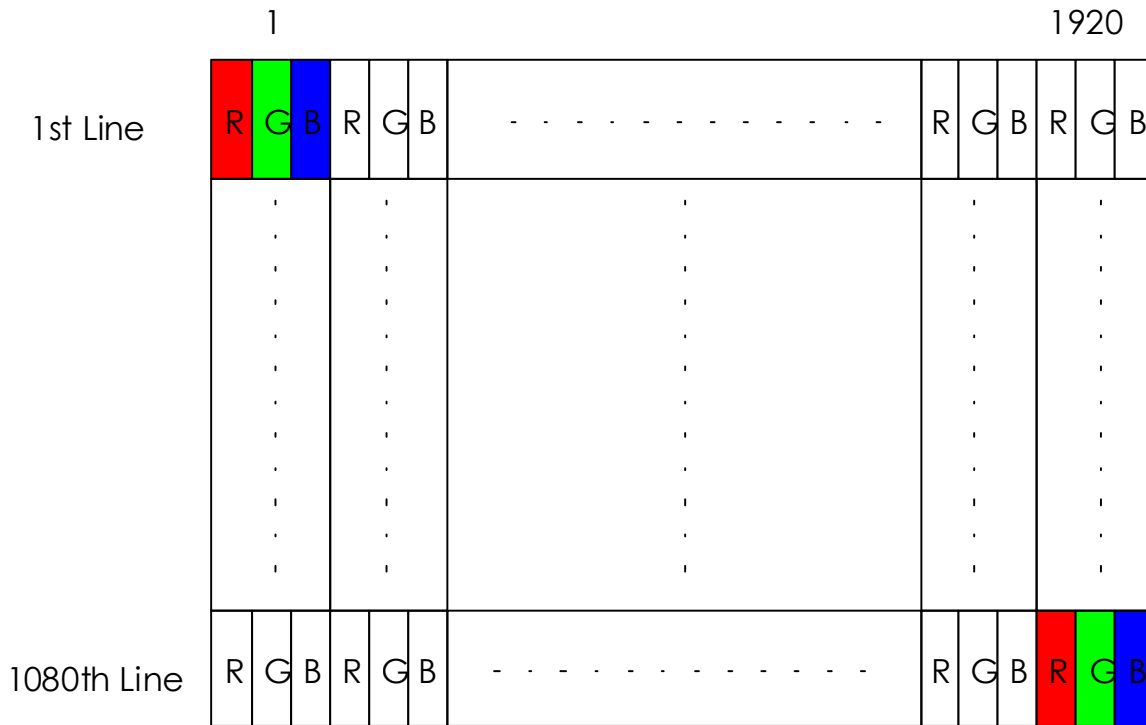



## 6.2 The Input Data Format

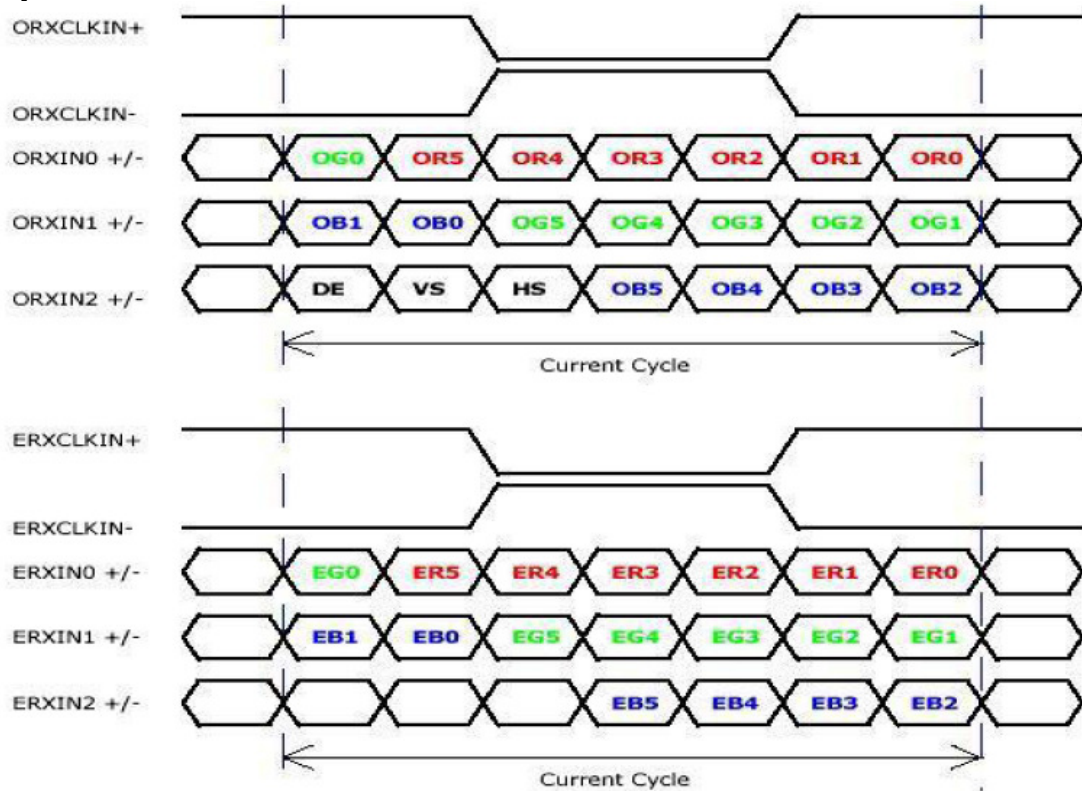

Signal Name	Description	
R5 R4 R3 R2 R1 R0	Red Data 5 (MSB) Red Data 4 Red Data 3 Red Data 2 Red Data 1 Red Data 0 (LSB)  Red-pixel Data	Red-pixel Data Each red pixel's brightness data consists of these 6 bits pixel data.
G5 G4 G3 G2 G1 G0	Green Data 5 (MSB) Green Data 4 Green Data 3 Green Data 2 Green Data 1 Green Data 0 (LSB)  Green-pixel Data	Green-pixel Data Each green pixel's brightness data consists of these 6 bits pixel data.
B5 B4 B3 B2 B1 B0	Blue Data 5 (MSB) Blue Data 4 Blue Data 3 Blue Data 2 Blue Data 1 Blue Data 0 (LSB)  Blue-pixel Data	Blue-pixel Data Each blue pixel's brightness data consists of these 6 bits pixel data.
RxCLKIN	Data Clock	The signal is used to strobe the pixel data and DE signals. All pixel data shall be valid at the falling edge when the DE signal is high.
DE	Display Timing	This signal is strobed at the falling edge of RxCLKIN. When the signal is high, the pixel data shall be valid to be displayed.
VS	Vertical Sync	The signal is synchronized to RxCLKIN .
HS	Horizontal Sync	The signal is synchronized to RxCLKIN .

Note: Output signals from any system shall be low or High-impedance state when VDD is off.

## 6.3 Integration Interface Requirement

### 6.3.1 Connector Description

Physical interface is described as for the connector on module.

These connectors are capable of accommodating the following signals and will be following components.

Connector Name / Designation	For Signal Connector
Manufacturer	JAE or Compatible
Type / Part Number	JAE HD1S040HA1 or Compatible
Mating Housing/Part Number	JAE HD1S040HA1 or Compatible

### 6.3.2 Pin Assignment

LVDS is a differential signal technology for LCD interface and high speed data transfer device.

PIN#	Signal Name	Description
1	NC	No Connection
2	VDD	Power Supply +3.3V
3	VDD	Power Supply +3.3V
4	VEDID	EDID +3.3V Power
5	NC	No Connect (Reserve for M1 aging)
6	CLKEDID	EDID Clock Input
7	DATAEDID	EDID Data Input
8	RxOIN0-	-LVDS Differential Data INPUT(Odd R0-R5,G0)
9	RxOIN0+	+LVDS Differential Data INPUT(Odd R0-R5,G0)
10	VSS	Ground
11	RxOIN1-	-LVDS Differential Data INPUT(Odd G1-G5,B0-B1)
12	RxOIN1+	+LVDS Differential Data INPUT(Odd G1-G5,B0-B1)
13	VSS	Ground
14	RxOIN2-	-LVDS Differential Data INPUT(Odd B2-B5,HS,VS,DE)
15	RxOIN2+	+LVDS Differential Data INPUT(Odd B2-B5,HS,VS,DE)
16	VSS	Ground
17	RxOCKIN-	-LVDS Odd Differential Clock INPUT
18	RxOCKIN+	+LVDS Odd Differential Clock INPUT
19	VSS	Ground
20	RxEIN0-	-LVDS Differential Data INPUT(Even R0-R5,G0)
21	RxEIN0+	+LVDS Differential Data INPUT(Even R0-R5,G0)
22	VSS	Ground



# Product Specification

AU OPTRONICS CORPORATION

23	RxEIN1-	-LVDS Differential Data INPUT(Even G1-G5,B0-B1)
24	RxEIN1+	+LVDS Differential Data INPUT(Even G1-G5,B0-B1)
25	VSS	Ground
26	RxEIN2-	-LVDS Differential Data INPUT(Even B2-B5,HS,VS,DE)
27	RxEIN2+	+LVDS Differential Data INPUT(Even B2-B5,HS,VS,DE)
28	VSS	Ground
29	RxECKIN-	-LVDS Even Differential Clock INPUT
30	RxECKIN+	+LVDS Even Differential Clock INPUT
31	VLED_GND	LED Ground
32	VLED_GND	LED Ground
33	VLED_GND	LED Ground
34	NC	No Connection
35	S_PWMIN	System PWM Logic Input level
36	LED_EN	LED enable input level
37	NC	No Connection
38	VLED	LED Power Supply
39	VLED	LED Power Supply
40	VLED	LED Power Supply

Note1: Input signals shall be low or High-impedance state when VDD is off.

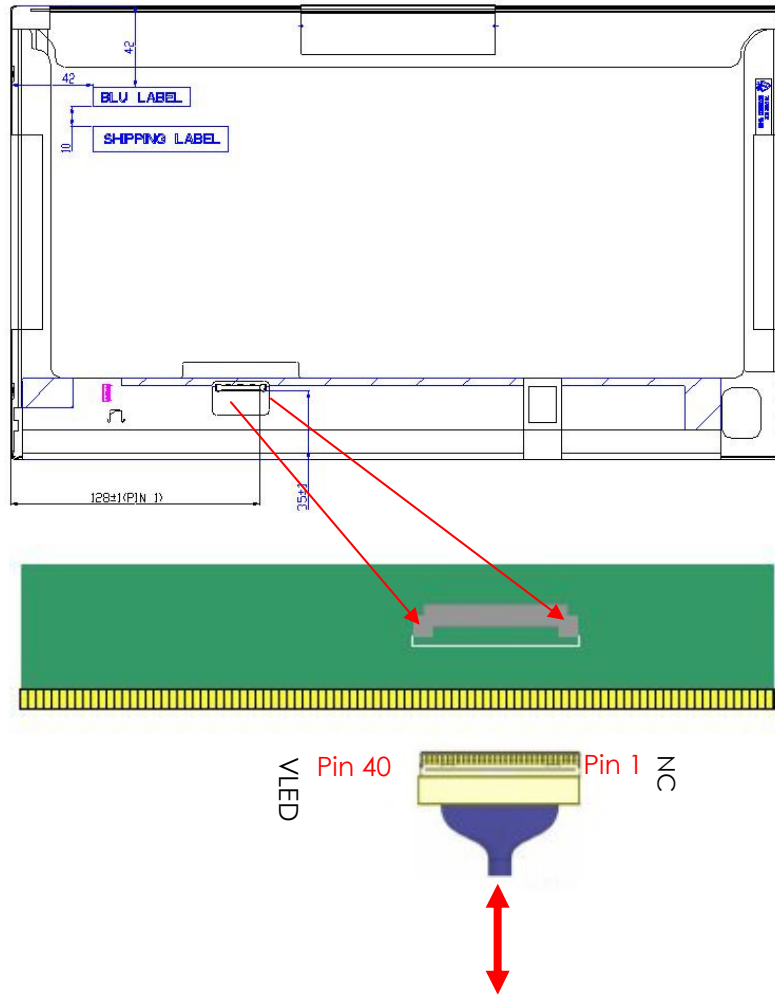

Note1: Input signals shall be low or High-impedance state when VDD is off.

## 6.4 Interface Timing

### 6.4.1 Timing Characteristics

Basically, interface timings should match the 1920X1080 / 60Hz manufacturing guide line timing.

Parameter	Symbol	Min.	Typ.	Max.	Unit	
Frame Rate	-	50	60	-	Hz	
Clock frequency	$1/T_{\text{Clock}}$	50	74.9	85	MHz	
Vertical Section	Period	$T_V$	1088	1130	1680	$T_{\text{Line}}$
	Active	$T_{VD}$	1080			
	Blanking	$T_{VB}$	8	50	-	
Horizontal Section	Period	$T_H$	990	1050	-	$T_{\text{Clock}}$
	Active	$T_{HD}$	960			
	Blanking	$T_{HB}$	30	90	-	

Note : DE mode only

### 6.4.2 Timing diagram

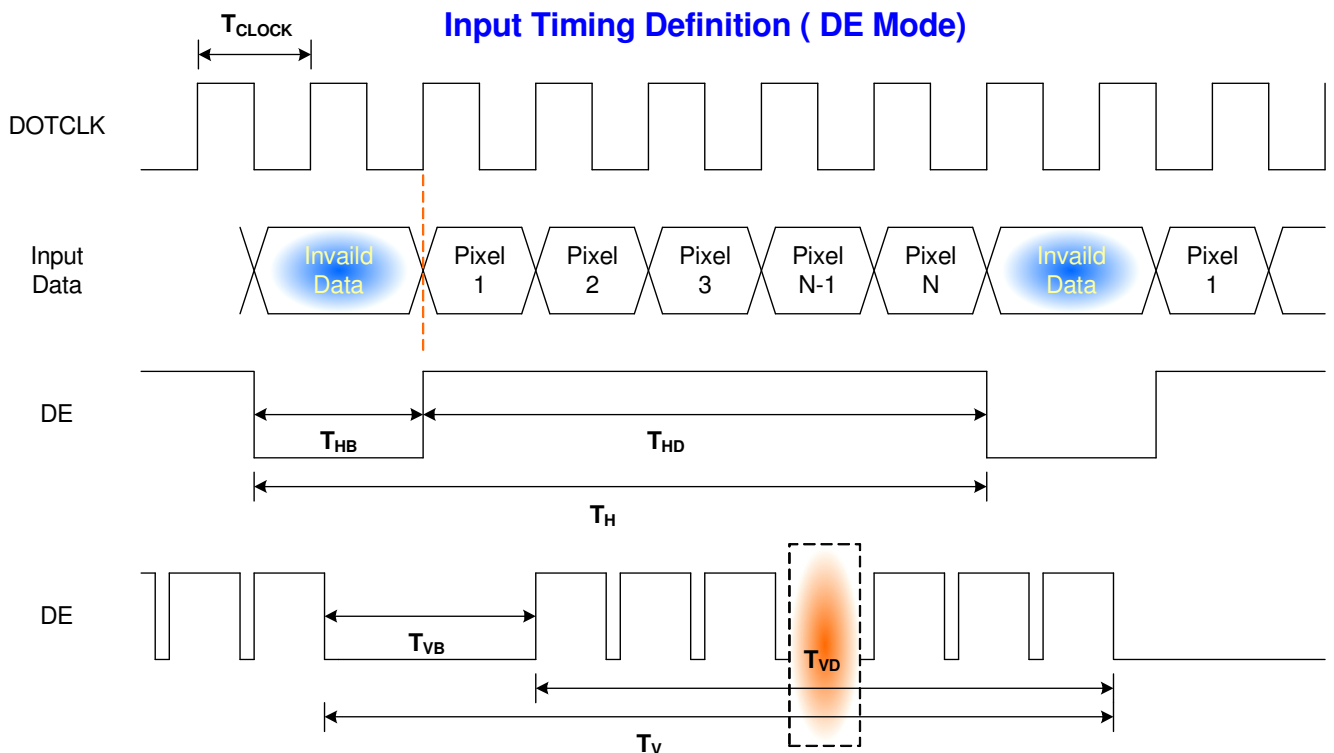

## 6.5 Power ON/OFF Sequence

Power on/off sequence is as follows. Interface signals and LED on/off sequence are also shown in the chart. Signals from any system shall be Hi-Z state or low level when VDD is off

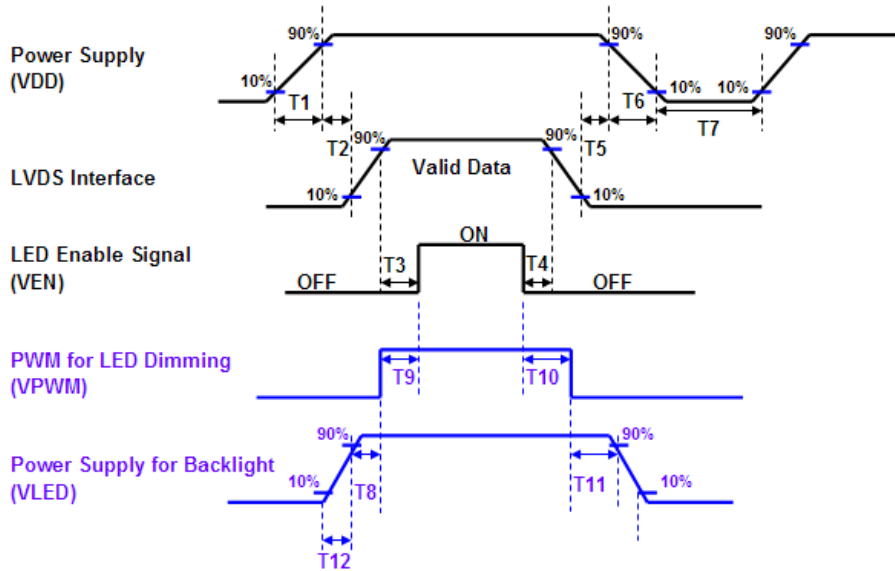

### Wiat for check with system

Power Sequence Timing		
Parameter	Value(Units: ms)	
	Min.	Max.
T1	0.5	10
T2	0	50
T3	200	-
T4	200	-
T5	0	50
T6	0	10
T7	500	-
T8	10	-
T9	10	180
T10	10	180
T11	10	-
T12	0.5	10

## 7. Panel Reliability Test

### 7.1 Vibration Test

**Test Spec:**

- Test method: Non-Operation
- Acceleration: 1.5 G
- Frequency: 10 - 500Hz Random
- Sweep: 30 Minutes each Axis (X, Y, Z)

### 7.2 Shock Test

**Test Spec:**

- Test method: Non-Operation
- Acceleration: 220 G , Half sine wave
- Active time: 2 ms
- Pulse: X,Y,Z .one time for each side

### 7.3 Reliability Test

Items	Required Condition	Note
Temperature Humidity Bias	Ta= 40°C , 90%RH, 300h	
High Temperature Operation	Ta= 50°C , Dry, 300h	
Low Temperature Operation	Ta= 0°C , 300h	
High Temperature Storage	Ta= 60°C , 35%RH, 300h	
Low Temperature Storage	Ta= -20°C , 50%RH, 250h	
Thermal Shock Test	Ta=-20°C to 60°C , Duration at 30 min, 100 cycles	
ESD	Contact : ±8 KV Air : ±15 KV	Note 1

**Note1:** According to EN 61000-4-2 , ESD class B: Some performance degradation allowed. No data lost . Self-recoverable. No hardware failures.

**Remark:** MTBF (Excluding the LED): 30,000 hours with a confidence level 90%



# Product Specification

AU OPTRONICS CORPORATION

## 8. Mechanical Characteristics

### 8.1 LCM Outline Dimension

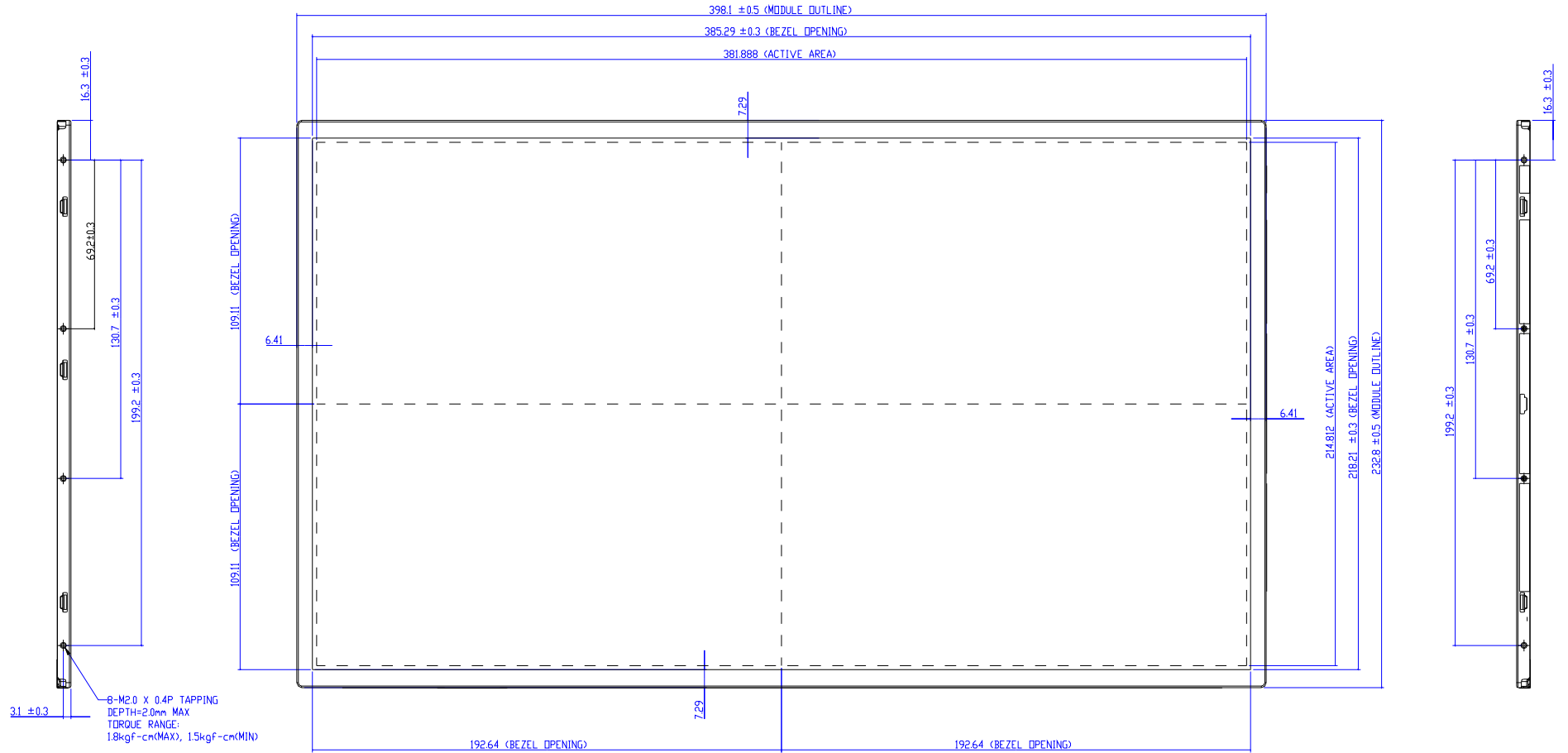





## 8.2 Screw Hole Depth and Center Position

Maximum Screw penetration from side surface is 2.3 mm

The center of screw hole center location is  $3.1 \pm 0.2$ mm from front surface

Screw Torque: Maximum 2.5 kgf-cm

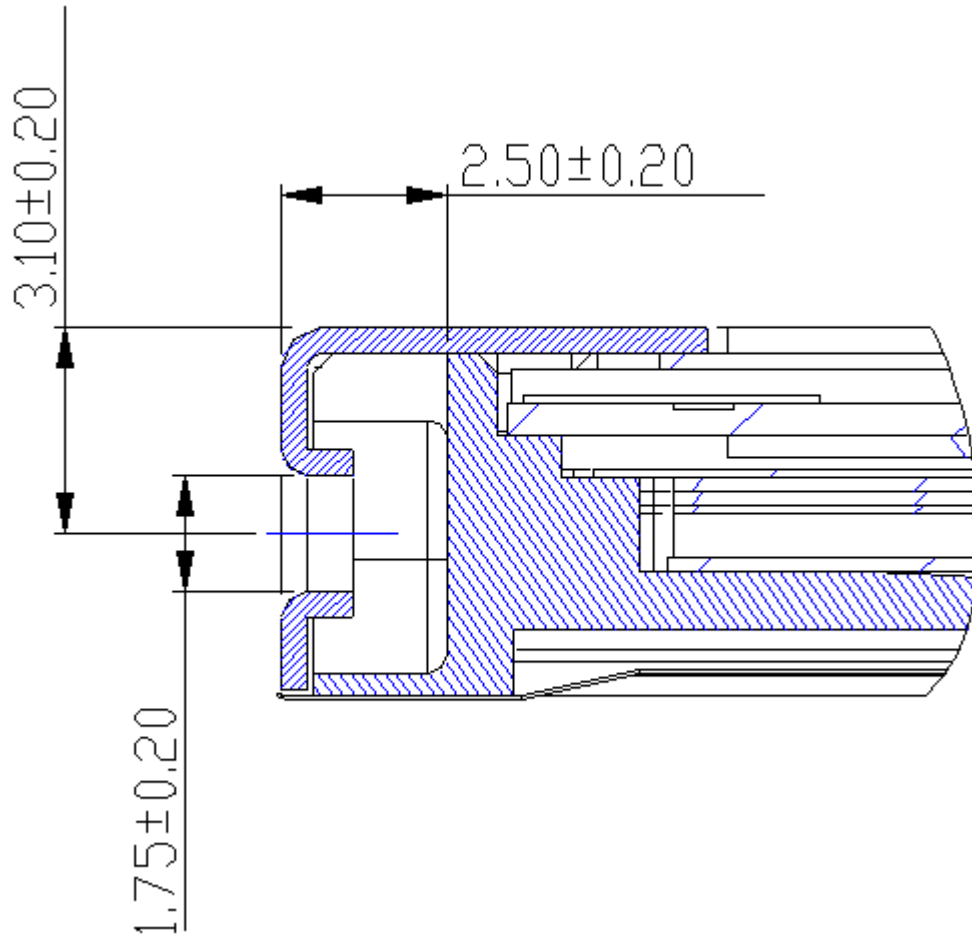

## 9. Shipping and Package

### 9.1 Shipping Label Format

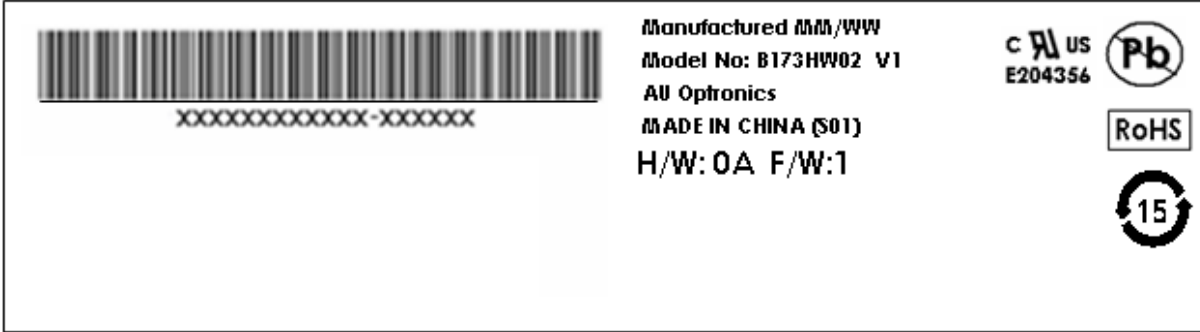

### 9.2 Carton Package

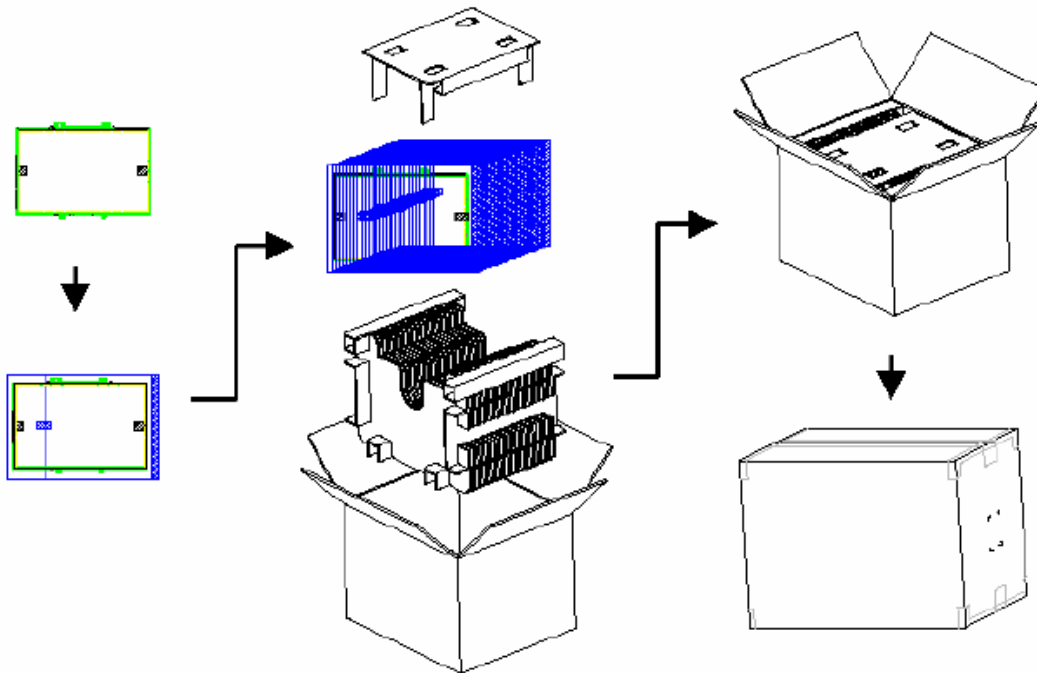

## 9.3 Shipping Package of Palletizing Sequence

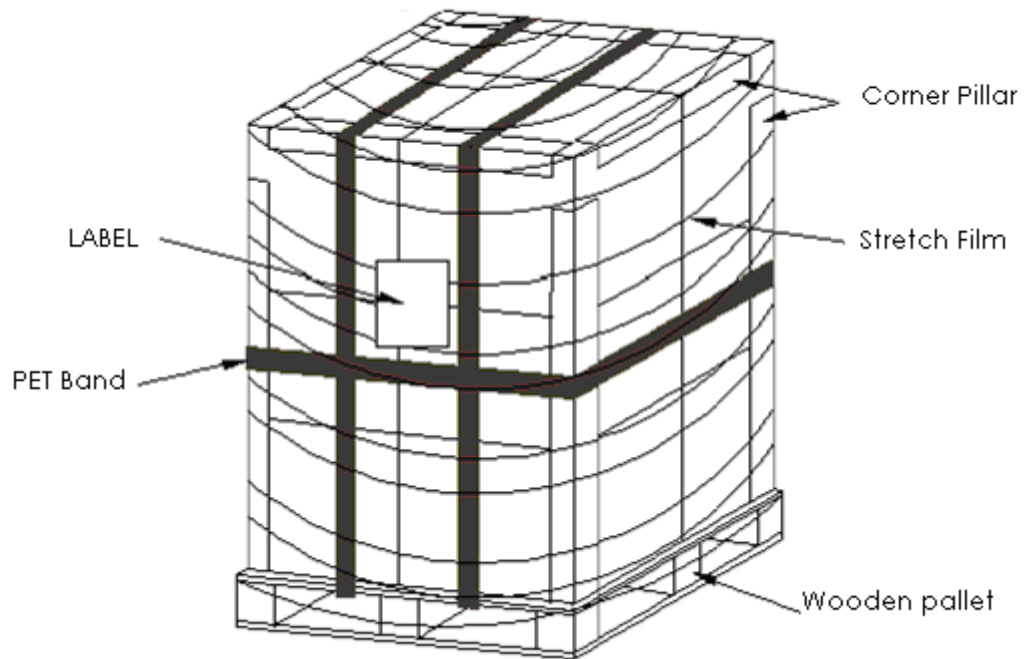

## 10. Appendix: EDID Description

	Byte	Field Name and Comments	Value	Value	Value
	(hex)		(hex)	(binary)	(DEC)
Header	0	Header	TBD	TBD	TBD
	1	Header	TBD	TBD	TBD
	2	Header	TBD	TBD	TBD
	3	Header	TBD	TBD	TBD
	4	Header	TBD	TBD	TBD
	5	Header	TBD	TBD	TBD
	6	Header	TBD	TBD	TBD
	7	Header	TBD	TBD	TBD
Vendor / Product EDID Version	8	EISA manufacture code = 3 Character ID	TBD	TBD	TBD
	9	EISA manufacture code (Compressed ASCII)	TBD	TBD	TBD
	0A	Panel Supplier Reserved – Product Code	TBD	TBD	TBD
	0B	Panel Supplier Reserved – Product Code	TBD	TBD	TBD
	0C	LCD module Serial No - Preferred but Optional (“0” if not used)	TBD	TBD	TBD
	0D	LCD module Serial No - Preferred but Optional (“0” if not used)	TBD	TBD	TBD
	0E	LCD module Serial No - Preferred but Optional (“0” if not used)	TBD	TBD	TBD
	0F	LCD module Serial No - Preferred but Optional (“0” if not used)	TBD	TBD	TBD
	10	Week of manufacture	TBD	TBD	TBD
	11	Year of manufacture	TBD	TBD	TBD
	12	EDID structure version # = 1	TBD	TBD	TBD
	13	EDID revision # = 4	TBD	TBD	TBD
	Display Parameters	14	Video I/P definition = Digital I/P (90 (6-bit) or A0 (8-Bit))	TBD	TBD
15		Max H image size = ?? cm(Rounded to cm)	TBD	TBD	TBD
16		Max V image size = ?? cm(Rounded to cm)	TBD	TBD	TBD
17		Display gamma = (gamma ×100)-100 = Example: ( 2.2×100 ) – 100 = 120	TBD	TBD	TBD
18		Feature support	TBD	TBD	TBD
Panel Color Coordinates	19	Red/Green Low bit (RxRy/GxGy)	TBD	TBD	TBD
	1A	Blue/White Low bit (BxBy/WxWy)	TBD	TBD	TBD
	1B	Red X Rx = 0.???	TBD	TBD	TBD
	1C	Red Y Ry = 0.???	TBD	TBD	TBD
	1D	Green X Rx = 0.???	TBD	TBD	TBD
	1E	Green Y Ry = 0.???	TBD	TBD	TBD
	1F	Blue X Rx = 0.???	TBD	TBD	TBD
	20	Blue Y Ry = 0.???	TBD	TBD	TBD
	21	White X Rx = 0.???	TBD	TBD	TBD
	22	White Y Ry = 0.???	TBD	TBD	TBD



# Product Specification

AU OPTRONICS CORPORATION

Established Timings	23	Established timings 1 (00h if not used)	TBD	TBD	TBD
	24	Established timings 2 (00h if not used)	TBD	TBD	TBD
	25	Manufacturer's timings (00h if not used)	TBD	TBD	TBD
Standard Timing ID	26	Standard timing ID1 (01h if not used)	TBD	TBD	TBD
	27	Standard timing ID1 (01h if not used)	TBD	TBD	TBD
	28	Standard timing ID2 (01h if not used)	TBD	TBD	TBD
	29	Standard timing ID2 (01h if not used)	TBD	TBD	TBD
	2A	Standard timing ID3 (01h if not used)	TBD	TBD	TBD
	2B	Standard timing ID3 (01h if not used)	TBD	TBD	TBD
	2C	Standard timing ID4 (01h if not used)	TBD	TBD	TBD
	2D	Standard timing ID4 (01h if not used)	TBD	TBD	TBD
	2E	Standard timing ID5 (01h if not used)	TBD	TBD	TBD
	2F	Standard timing ID5 (01h if not used)	TBD	TBD	TBD
	30	Standard timing ID6 (01h if not used)	TBD	TBD	TBD
	31	Standard timing ID6 (01h if not used)	TBD	TBD	TBD
	32	Standard timing ID7 (01h if not used)	TBD	TBD	TBD
	33	Standard timing ID7 (01h if not used)	TBD	TBD	TBD
	34	Standard timing ID8 (01h if not used)	TBD	TBD	TBD
	35	Standard timing ID8 (01h if not used)	TBD	TBD	TBD
	Timing Descriptor #1	36	Pixel Clock/10,000 (LSB)	TBD	TBD
37		Pixel Clock/10,000 (MSB)	TBD	TBD	TBD
38		Horizontal Active = ??? pixels (lower 8 bits)	TBD	TBD	TBD
39		Horizontal Blanking (Thbp) = 320 pixels (lower 8 bits)	TBD	TBD	TBD
3A		Horizontal Active/Horizontal blanking (Thbp) (upper 4:4 bits)	TBD	TBD	TBD
3B		Vertical Active = ??? lines	TBD	TBD	TBD
3C		Vertical Blanking (Tvbp) = ?? lines (DE Blanking typ. for DE only panels)	TBD	TBD	TBD
3D		Vertical Active : Vertical Blanking (Tvbp) (upper 4:4 bits)	TBD	TBD	TBD
3E		Horizontal Sync, Offset (Thfp) = ?? pixels	TBD	TBD	TBD
3F		Horizontal Sync, Pulse Width = ??? pixels	TBD	TBD	TBD
40		Vertical Sync, Offset (Tvfp) = ? lines Sync Width = ? lines	TBD	TBD	TBD
41		Horizontal Vertical Sync Offset/Width upper 2 bits	TBD	TBD	TBD
42		Horizontal Image Size = ??? mm	TBD	TBD	TBD
43		Vertical image Size = ??? mm	TBD	TBD	TBD
44		Horizontal Image Size / Vertical image size	TBD	TBD	TBD
45		Horizontal Border = 0 (Zero for Notebook LCD)	TBD	TBD	TBD
46		Vertical Border = 0 (Zero for Notebook LCD)	TBD	TBD	TBD



# Product Specification

AU OPTRONICS CORPORATION

	47	Bit[7] 0 : Non-interlace, 1: Interlace Bit[6:5] 00: Normal display, no strero, see VESA EDID Spec 1.3 Bit[4:3] 00: Analog composite, 01: Bipolar analog composite, 10: Digital composite, 11: Digital separate Bit[2:1] : The interpretation of bits 2 and 1 is dependent on the decode of bits 4 and 3 - see VESA EDID Spec 1.3 Bit[0] : See VESA EDID Spec 1.3 ==> fix=1A	TBD	TBD	TBD
Timing Descriptor #2 (=Timing Descriptor #1)	48	Pixel Clock/10,000 (LSB)	TBD	TBD	TBD
	49	Pixel Clock/10,000 (MSB)	TBD	TBD	TBD
	4A	Horizontal Active = xxxx pixels (lower 8 bits)	TBD	TBD	TBD
	4B	Horizontal Blanking (Thbp) = xxxx pixels (lower 8 bits)	TBD	TBD	TBD
	4C	Horizontal Active/Horizontal blanking (Thbp) (upper4:4 bits)	TBD	TBD	TBD
	4D	Vertical Active = xxxx lines	TBD	TBD	TBD
	4E	Vertical Blanking (Tvbp) = xxxx lines (DE Blanking typ. for DE only panels)	TBD	TBD	TBD
	4F	Vertical Active : Vertical Blanking (Tvbp) (upper4:4 bits)	TBD	TBD	TBD
	50	Horizontal Sync, Offset (Thfp) = xxxx pixels	TBD	TBD	TBD
	51	Horizontal Sync, Pulse Width = xxxx pixels	TBD	TBD	TBD
	52	Vertical Sync, Offset (Tvfp) = xx lines Sync Width = xx lines	TBD	TBD	TBD
	53	Horizontal Vertical Sync Offset/Width upper 2 bits	TBD	TBD	TBD
	54	Horizontal Image Size =xxx mm	TBD	TBD	TBD
	55	Vertical image Size = xxx mm	TBD	TBD	TBD
	56	Horizontal Image Size / Vertical image size	TBD	TBD	TBD
	57	Horizontal Border = 0 (Zero for Notebook LCD)	TBD	TBD	TBD
	58	Vertical Border = 0 (Zero for Notebook LCD)	TBD	TBD	TBD
		59	Bit[7] 0 : Non-interlace, 1: Interlace Bit[6:5] 00: Normal display, no strero, see VESA EDID Spec 1.3 Bit[4:3] 00: Analog composite, 01: Bipolar analog composite, 10: Digital composite, 11: Digital separate Bit[2:1] : The interpretation of bits 2 and 1 is dependent on the decode of bits 4 and 3 - see VESA EDID Spec 1.3 Bit[0] : See VESA EDID Spec 1.3 ==> fix=1A	TBD	TBD
Timing Descriptor #3 Dell specific information	5A	Flag	TBD	TBD	TBD
	5B	Flag	TBD	TBD	TBD
	5C	Flag	TBD	TBD	TBD
	5D	Data Type Tag: Alphanumeric Data String (ASCII) ==> fix=FE	TBD	TBD	TBD
	5E	Flag	TBD	TBD	TBD
	5F	Dell P/N 1 <sup>st</sup> Character	TBD	TBD	TBD
	60	Dell P/N 2 <sup>nd</sup> Character	TBD	TBD	TBD
	61	Dell P/N 3 <sup>rd</sup> Character	TBD	TBD	TBD



# Product Specification

AU OPTRONICS CORPORATION

	62	Dell P/N 4 <sup>th</sup> Character	TBD	TBD	TBD
	63	Dell P/N 5 <sup>th</sup> Character	TBD	TBD	TBD
	64	<b>EDID Revision</b> <b>Bit[6:0] See charts below</b> <b>Bit[7] 0: X-rev, 1: A-rev</b>	TBD	TBD	TBD
	65	Manufacturer P/N	TBD	TBD	TBD
	66	Manufacturer P/N	TBD	TBD	TBD
	67	Manufacturer P/N	TBD	TBD	TBD
	68	Manufacturer P/N	TBD	TBD	TBD
	69	Manufacturer P/N	TBD	TBD	TBD
	6A	Manufacturer P/N	TBD	TBD	TBD
	6B	Manufacturer P/N (If <13 char, then terminate with ASCII code 0Ah, set remaining char = 20h)	TBD	TBD	TBD
	Timing Descriptor #4	6C	Flag	TBD	TBD
6D		Flag	TBD	TBD	TBD
6E		Flag	TBD	TBD	TBD
6F		Data Type Tag: Manufacturer Specified Data 00 ==>fix=00	TBD	TBD	TBD
70		Flag	TBD	TBD	TBD
71		Color Management	TBD	TBD	TBD
72		Panel Structure	TBD	TBD	TBD
73		Frame Rate	TBD	TBD	TBD
74		Light Controller Interface and Luminance	TBD	TBD	TBD
75		Outdoor Features	TBD	TBD	TBD
76		Multi-Media Features	TBD	TBD	TBD
77		Multi-Media Features	TBD	TBD	TBD
78		Special Features #1	TBD	TBD	TBD
79		Special Features #2	TBD	TBD	TBD
7A		Special Features #3	TBD	TBD	TBD
7B		(If <13 char, then terminate with ASCII code 0Ah, set remaining char = 20h)	TBD	TBD	TBD
7C		(If <13 char, then terminate with ASCII code 0Ah, set remaining char = 20h)	TBD	TBD	TBD
7D	(If <13 char, then terminate with ASCII code 0Ah, set remaining char = 20h)	TBD	TBD	TBD	
Checksum	7E	Extension flag (# of optional 128 EDID extension blocks to follow, Typ = 0)	TBD	TBD	TBD
	7F	Checksum (The 1-byte sum of all 128 bytes in this EDID block shall = 0)	TBD	TBD	TBD