



Product Specification

AU OPTRONICS CORPORATION

() Preliminary Specifications

(V) Final Specifications

Module	17.3"(17.26) HD+ 16:9 Color TFT-LCD with LED Backlight design
Model Name	B173RTN01.2 (HW:0A)
Note ()	<i>LED Backlight with driving circuit design</i>

Customer	Date
<u>ASUS</u>	<u>02/13/2012</u>
Checked & Approved by	Date
_____	_____
<p>Note: This Specification is subject to change without notice.</p>	

Approved by	Date
<u>Claire Yu</u>	<u>02/13/2012</u>
Prepared by	Date
<u>Claire Yu</u>	<u>02/13/2012</u>
<p>NBBU Marketing Division / AU Optronics corporation</p>	



Product Specification

AU OPTRONICS CORPORATION

Contents

1. Handling Precautions	4
2. General Description	5
2.1 General Specification	5
2.2 Optical Characteristics	6
3. Functional Block Diagram	11
4. Absolute Maximum Ratings	12
4.1 Absolute Ratings of TFT LCD Module	12
4.2 Absolute Ratings of Environment	12
5. Electrical characteristics	13
5.1 TFT LCD Module	13
5.2 Backlight Unit	15
5.2.1 LED characteristics	15
6. Signal Characteristic	16
6.1 Pixel Format Image	16
6.2 The input data format	17
6.3 Integration Interface and Pin Assignment	18
6.3.1 Connector Description	18
6.4 Interface Timing	20
7. Vibration and Shock Test	22
7.1 Vibration Test	22
7.2 Shock Test Spec:	22
7.3. Reliability	22
8. Mechanical Characteristics	23
8.1 LCM Outline Dimension	23
8.2 Screw Hole Depth and Center Position	25
9. Shipping and Package	26
9.1 Shipping Label Format	26
9.2. Carton package	27
9.3 Shipping package of palletizing sequence	27
10. Appendix: EDID description	28



Product Specification

AU OPTRONICS CORPORATION

Record of Revision

Version and Date	Page	Old description	New Description	Remark
0.0 2011/12/07	All	Preliminary Edition for Customer		
0.1 2011/12/12	29-31		Update EDID	
0.2 2012/2/13	1 29-31		(1) Final version (2) Update EDID for WWAN solution	



Product Specification

AU OPTRONICS CORPORATION

1. Handling Precautions

- 1) Since front polarizer is easily damaged, pay attention not to scratch it.
- 2) Be sure to turn off power supply when inserting or disconnecting from input connector.
- 3) Wipe off water drop immediately. Long contact with water may cause discoloration or spots.
- 4) When the panel surface is soiled, wipe it with absorbent cotton or other soft cloth.
- 5) Since the panel is made of glass, it may break or crack if dropped or bumped on hard surface.
- 6) Since CMOS LSI is used in this module, take care of static electricity and insure human earth when handling.
- 7) Do not open nor modify the Module Assembly.
- 8) Do not press the reflector sheet at the back of the module to any directions.
- 9) At the insertion or removal of the Signal Interface Connector, be sure not to rotate nor tilt the Interface Connector of the TFT Module.
- 11) After installation of the TFT Module into an enclosure (Notebook PC Bezel, for example), do not twist nor bend the TFT Module even momentary. At designing the enclosure, it should be taken into consideration that no bending/twisting forces are applied to the TFT Module from outside. Otherwise the TFT Module may be damaged.
- 12) Small amount of materials having no flammability grade is used in the LCD module. The LCD module should be supplied by power complied with requirements of Limited Power Source (IEC60950 or UL1950), or be applied exemption.
- 13) Disconnecting power supply before handling LCD modules, it can prevent electric shock, DO NOT TOUCH the electrode parts, cables, connectors and LED circuit part of TFT module that a LED light bar build in as a light source of back light unit. It can prevent electrostatic breakdown.



Product Specification

AU OPTRONICS CORPORATION

2. General Description

B173RTN01.2 is a Color Active Matrix Liquid Crystal Display composed of a TFT LCD panel, a driver circuit, and LED backlight system. The screen format is intended to support the 16:9 HD+ (1600(H) x 900(V)) screen and 262k colors (RGB 6-bits data driver) with LED backlight driving circuit. All input signals are LVDS interface compatible.

B173RTN01.2 is designed for a display unit of notebook style personal computer and industrial machine.

2.1 General Specification

The following items are characteristics summary on the table at 25 °C condition:

Items	Unit	Specifications			
Screen Diagonal	[mm]	17.3"(17.26)			
Active Area	[mm]	382.08 X 214.92			
Pixels H x V		1600x3(RGB) x 900			
Pixel Pitch	[mm]	0.2388X0.2388			
Pixel Format		R.G.B. Vertical Stripe			
Display Mode		Normally White			
White Luminance	[cd/m ²]	200 typ. (5 points average) 170 min. (5 points average)			
Luminance Uniformity		1.25 max. (5 points)			
Contrast Ratio		400:1 typ			
Response Time	[ms]	8 typ/16max			
Nominal Input Voltage VDD	[Volt]	+3.3 typ.			
Power Consumption	[Watt]	6.5 max. (Include Logic and Blu power)			
Weight	[Grams]	570 max.			
Physical Size Without inverter, bracket.	[mm]		Min.	Typ.	Max.
		Length	397.6	398.1	398.6
		Width	232.3	232.8	233.3
		Thickness	-	-	5.8
Electrical Interface		2 channel LVDS			
Glass Thickness	[mm]	0.5			
Surface Treatment		AG, Hardness 3H			
Support Color		262K colors (RGB 6-bit)			
Temperature Range	Operating	[°C]	0 to +50		
	Storage (Non-Operating)	[°C]	-20 to +60		
RoHS Compliance		RoHS Compliance			



Product Specification

AU OPTRONICS CORPORATION

2.2 Optical Characteristics

The optical characteristics are measured under stable conditions at 25°C (Room Temperature) :

Item	Symbol	Conditions	Min.	Typ.	Max.	Unit	Note
White Luminance ILED=20mA		5 points average	170	200	-	cd/m ²	1, 4, 5.
Viewing Angle	θ_R θ_L	Horizontal (Right) CR = 10 (Left)		70 70	- -	degree	4, 9
	ψ_H ψ_L	Vertical (Upper) CR = 10 (Lower)		60 60	- -		
Luminance Uniformity	δ_{5P}	5 Points	-	-	1.25		1, 3, 4
Luminance Uniformity	δ_{13P}	13 Points	-	-	1.60		2, 3, 4
Contrast Ratio	CR		300	400	-		4, 6
Cross talk	%				4		4, 7
Response Time	T_{RT}	Rising + Falling	-	8	16		
Color / Chromaticity Coordinates	Red	Rx	CIE 1931	0.590	0.620	0.650	4
		Ry		0.320	0.350	0.380	
	Green	Gx		0.285	0.315	0.345	
		Gy		0.585	0.615	0.645	
	Blue	Bx		0.120	0.150	0.180	
		By		0.083	0.113	0.143	
	White	Wx		0.283	0.313	0.343	
		Wy		0.299	0.329	0.359	
NTSC	%		-	60	-		



Product Specification

AU OPTRONICS CORPORATION

Note 1: 5 points position (Ref: Active area)

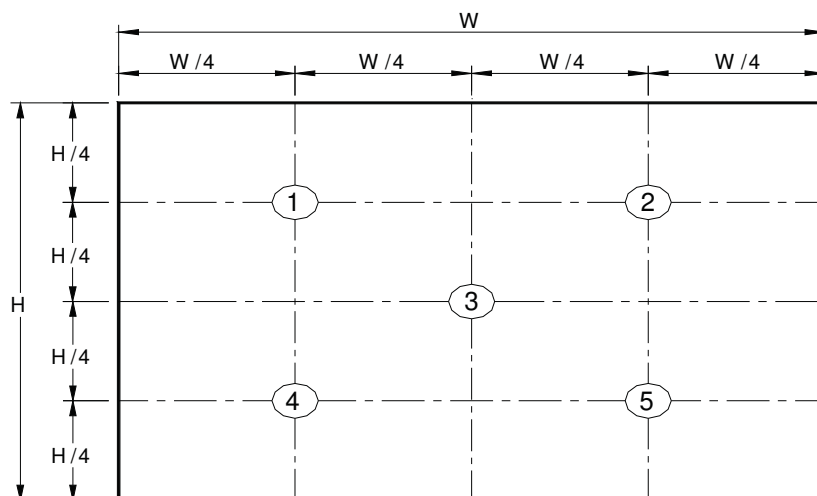

Note 2: 13 points position (Ref: Active area)

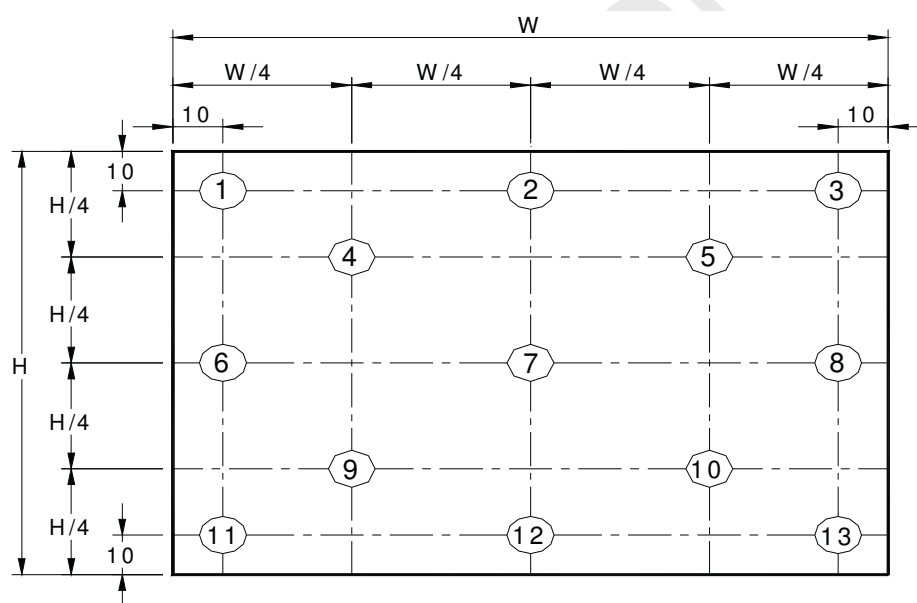

Note 3: The luminance uniformity of 5 or 13 points is defined by dividing the maximum luminance values by the minimum test point luminance

$$\delta_{w5} = \frac{\text{Maximum Brightness of five points}}{\text{Minimum Brightness of five points}}$$

$$\delta_{w13} = \frac{\text{Maximum Brightness of thirteen points}}{\text{Minimum Brightness of thirteen points}}$$

Note 4: Measurement method

The LCD module should be stabilized at given temperature for 30 minutes to avoid abrupt temperature change during measuring. In order to stabilize the luminance, the measurement should be executed after lighting Backlight



Product Specification

AU OPTRONICS CORPORATION

for 30 minutes in a stable, windless and dark room, and it should be be measured in the center of screen.

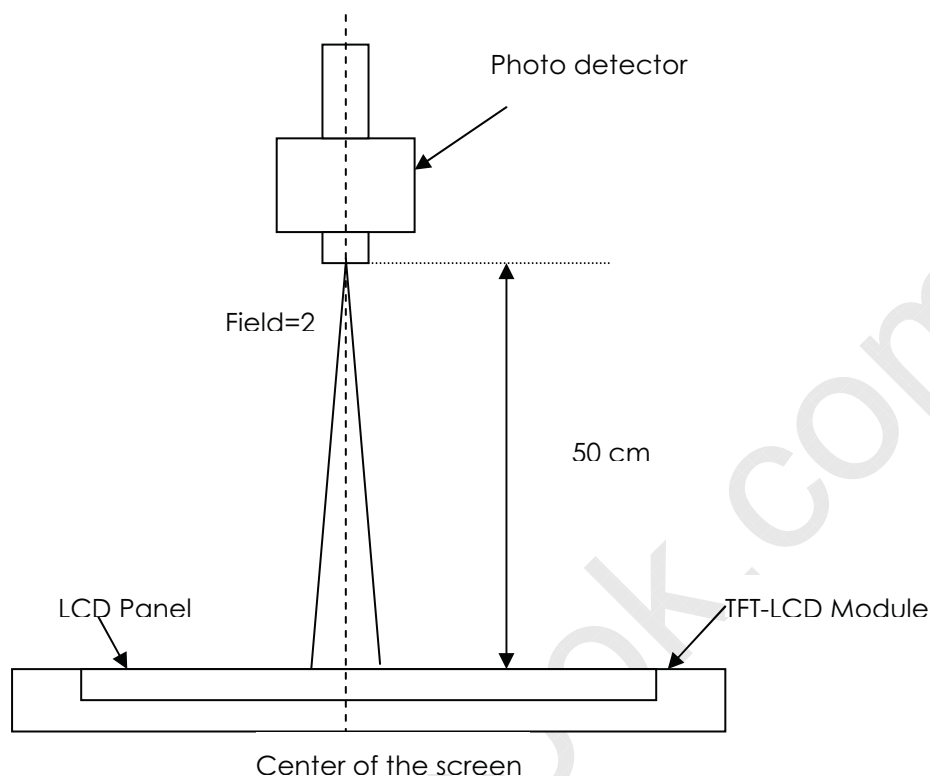

Note 5 : Definition of Average Luminance of White (Y_L):

Measure the luminance of gray level 63 at 5 points , $Y_L = [L(1) + L(2) + L(3) + L(4) + L(5)] / 5$

$L(x)$ is corresponding to the luminance of the point X at Figure in Note (1).

Note 6 : Definition of contrast ratio:

Contrast ratio is calculated with the following formula.

$$\text{Contrast ratio (CR)} = \frac{\text{Brightness on the "White" state}}{\text{Brightness on the "Black" state}}$$

Note 7 : Definition of Cross Talk (CT)

$$CT = |Y_B - Y_A| / Y_A \times 100 (\%)$$

Where

Y_A = Luminance of measured location without gray level 0 pattern (cd/m^2)

Y_B = Luminance of measured location with gray level 0 pattern (cd/m^2)



Product Specification

AU OPTRONICS CORPORATION

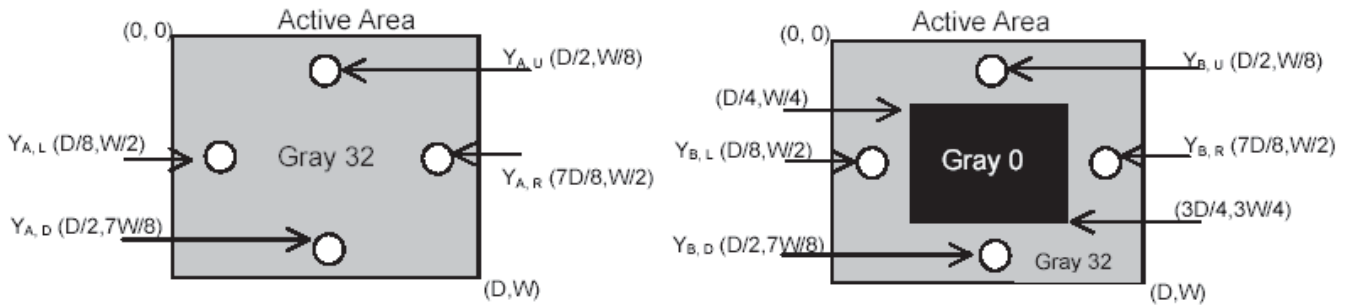

Note 8: Definition of response time:

The output signals of BM-7 or equivalent are measured when the input signals are changed from "Black" to "White" (falling time) and from "White" to "Black" (rising time), respectively. The response time interval between the 10% and 90% of amplitudes. Refer to figure as below.

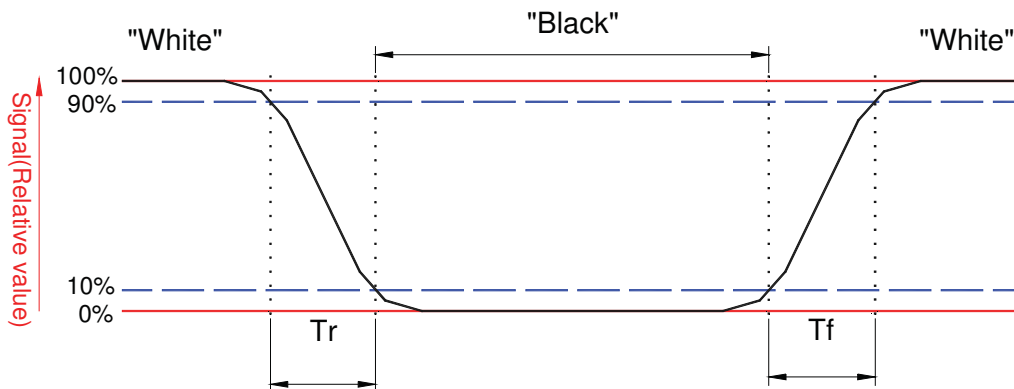



Product Specification

AU OPTRONICS CORPORATION

Note 9. Definition of viewing angle

Viewing angle is the measurement of contrast ratio ≥ 10 , at the screen center, over a 180° horizontal and 180° vertical range (off-normal viewing angles). The 180° viewing angle range is broken down as follows; 90° (θ) horizontal left and right and 90° (ϕ) vertical, high (up) and low (down). The measurement direction is typically perpendicular to the display surface with the screen rotated about its center to develop the desired measurement viewing angle.

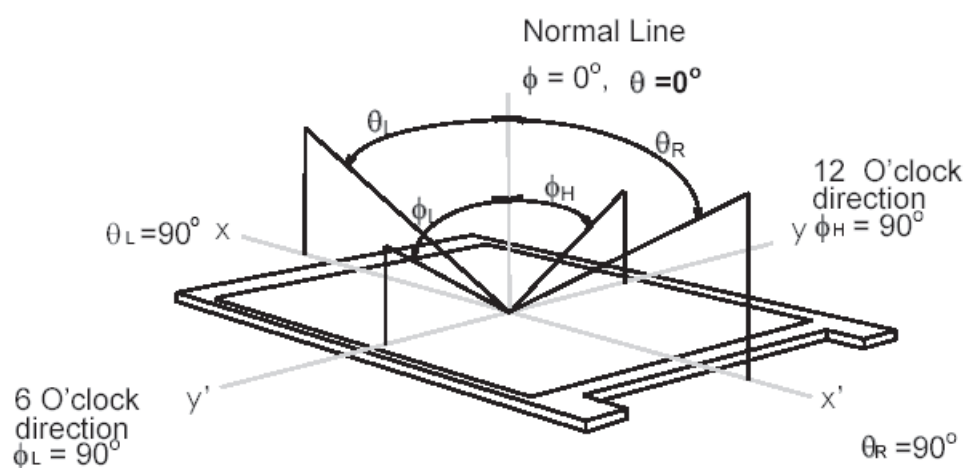



Product Specification

AU OPTRONICS CORPORATION

3. Functional Block Diagram

The following diagram shows the functional block of the 17.3 inches wide Color TFT/LCD 40 Pin.

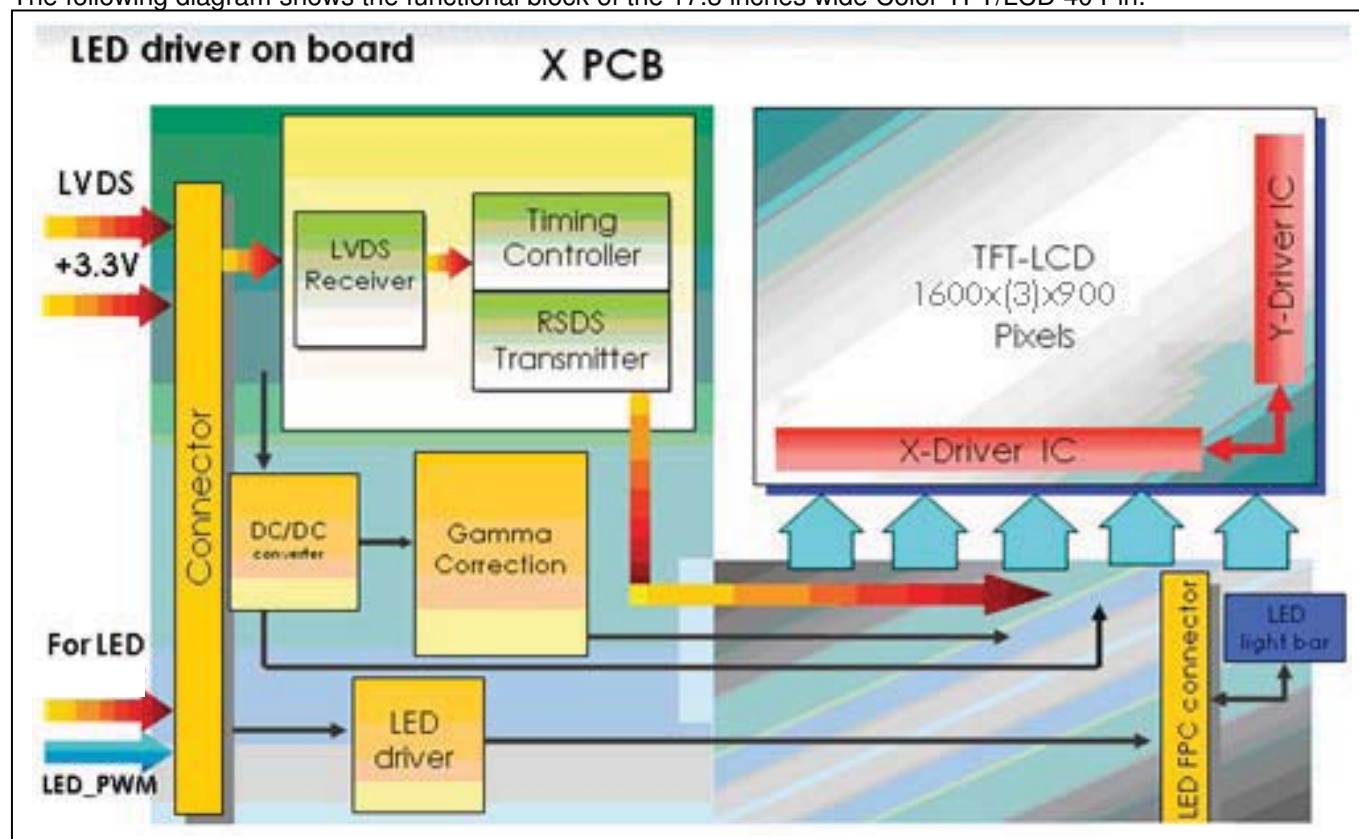



Product Specification

AU OPTRONICS CORPORATION

4. Absolute Maximum Ratings

An absolute maximum rating of the module is as following:

4.1 Absolute Ratings of TFT LCD Module

Item	Symbol	Min	Max	Unit	Conditions
Logic/LCD Drive Voltage	Vin	-0.3	+4.0	[Volt]	Note 1,2

4.2 Absolute Ratings of Environment

Item	Symbol	Min	Max	Unit	Conditions
Operating Temperature	TOP	0	+50	[°C]	Note 4
Operation Humidity	HOP	5	95	[%RH]	Note 4
Storage Temperature	TST	-20	+60	[°C]	Note 4
Storage Humidity	HST	5	95	[%RH]	Note 4

Note 1: At Ta (25°C)

Note 2: Permanent damage to the device may occur if exceed maximum values

Note 3: LED specification refer to section 5.2

Note 4: For quality performance, please refer to AUO IIS (Incoming Inspection Standard).

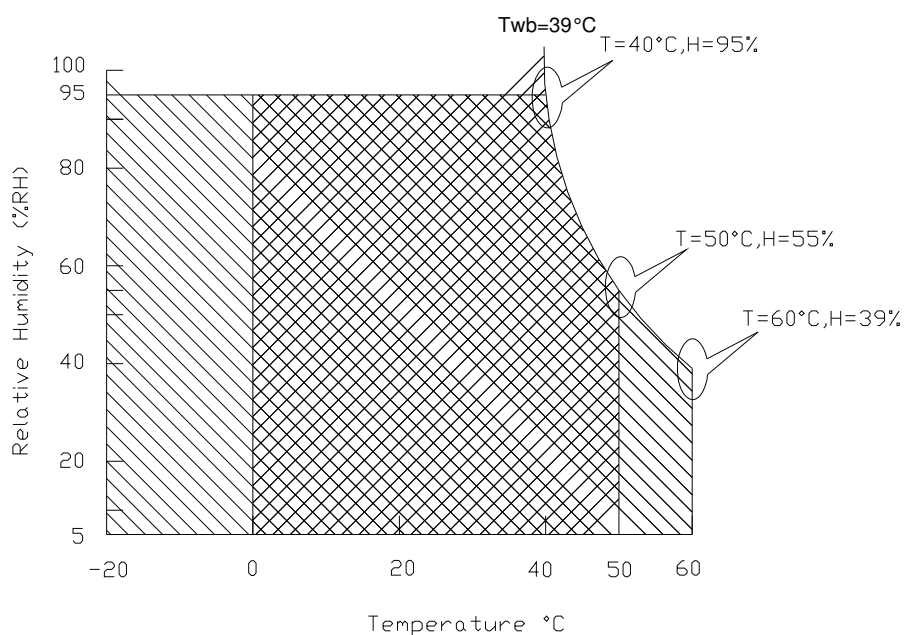

Operating Range

Storage Range +



Product Specification

AU OPTRONICS CORPORATION

5. Electrical characteristics

5.1 TFT LCD Module

5.1.1 Power Specification

Input power specifications are as follows;

The power specification are measured under 25°C and frame frequency under 60Hz

Symble	Parameter	Min	Typ	Max	Units	Note
VDD	Logic/LCD Drive Voltage	3.0	3.3	3.6	[Volt]	
PDD	VDD Power	-	-	1.5	[Watt]	Note 1/2
IDD	IDD Current	-	350	450	[mA]	Note 1/2
IRush	Inrush Current	-	-	2000	[mA]	Note 3
VDDrp	Allowable Logic/LCD Drive Ripple Voltage	-	-	100	[mV] p-p	

Note 1 : Maximum Measurement Condition : Black Pattern at 3.3V driving voltage. ($P_{max}=V_{3.3} \times I_{black}$)

Note 2 : Measure Condition

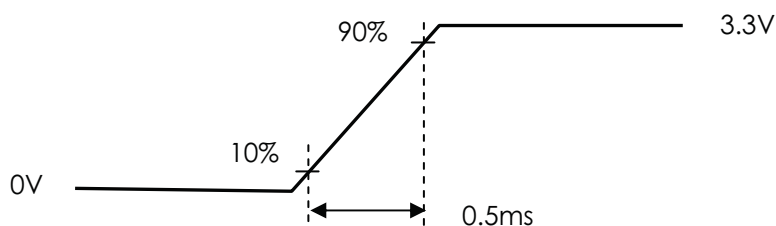
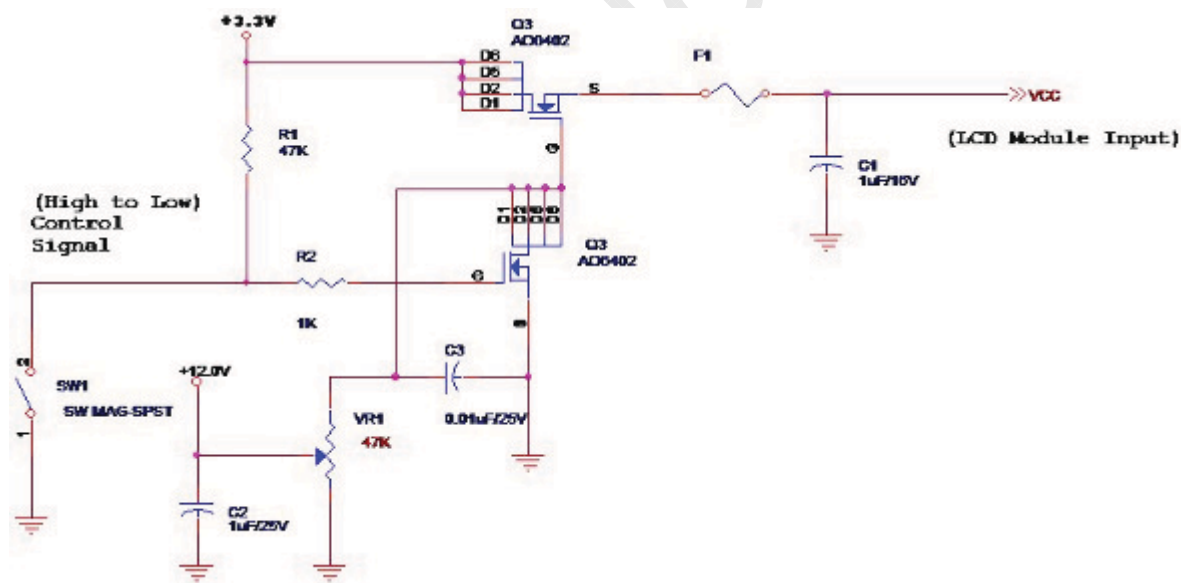

Vin rising time



Product Specification

AU OPTRONICS CORPORATION

5.1.2 Signal Electrical Characteristics

Input signals shall be low or High-impedance state when VDD is off.

Signal electrical characteristics are as follows;

Parameter	Condition	Min	Max	Unit
V _{th}	Differential Input High Threshold (V _{cm} =+1.2V)		100	[mV]
V _{tl}	Differential Input Low Threshold (V _{cm} =+1.2V)	-100		[mV]
V _{ID}	Differential Input Voltage	100	600	[mV]
V _{cm}	Differential Input Common Mode Voltage	1.125	1.375	[V]

Note: LVDS Signal Waveform

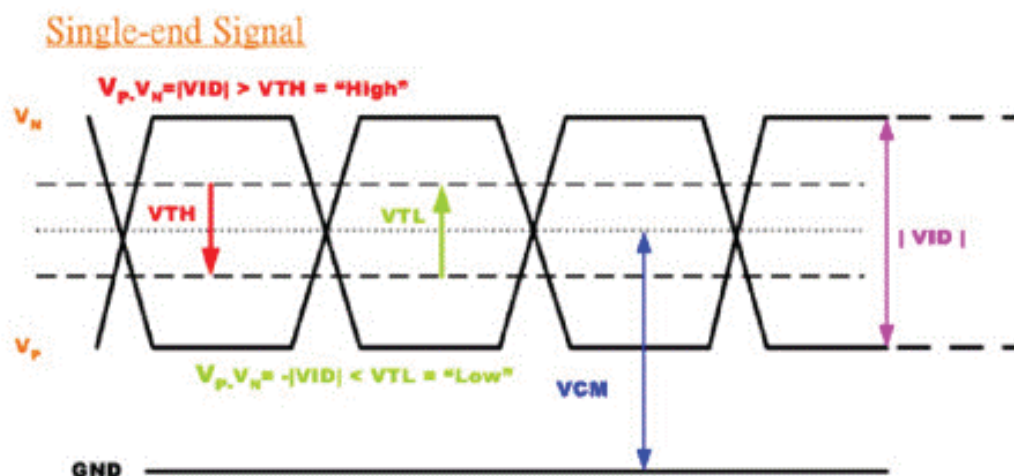



Product Specification

AU OPTRONICS CORPORATION

5.2 Backlight Unit

5.2.1 LED characteristics

Parameter	Symbol	Min	Typ	Max	Units	Condition
Backlight Power Consumption	PLED	-	4.8	5.0	[Watt]	(Ta=25°C), Note 1 Vin =12V
LED Life-Time	N/A	15,000	-	-	Hour	(Ta=25°C), Note 2

Note 1: Calculator value for reference $P_{LED} = VF$ (Normal Distribution) * IF (Normal Distribution) / Efficiency

Note 2: The LED life-time define as the estimated time to 50% degradation of initial luminous.

5.2.2 Backlight input signal characteristics

Parameter	Symbol	Min	Typ	Max	Units	Remark
LED Power Supply	VLED	6	--	21	[Volt]	Define as Connector Interface (Ta=25°C)
LED Enable Input High Level	VLED_EN	3	-	5.5	[Volt]	
LED Enable Input Low Level		-	-	0.8	[Volt]	
PWM Logic Input High Level	VPWM_EN	3	-	5.5	[Volt]	
PWM Logic Input Low Level		-	-	0.8	[Volt]	
PWM Input Frequency	FPWM	200	1K	10k	Hz	
PWM Duty Ratio	Duty	5	--	100	%	



Product Specification

AU OPTRONICS CORPORATION

6. Signal Characteristic

6.1 Pixel Format Image

Following figure shows the relationship of the input signals and LCD pixel format.

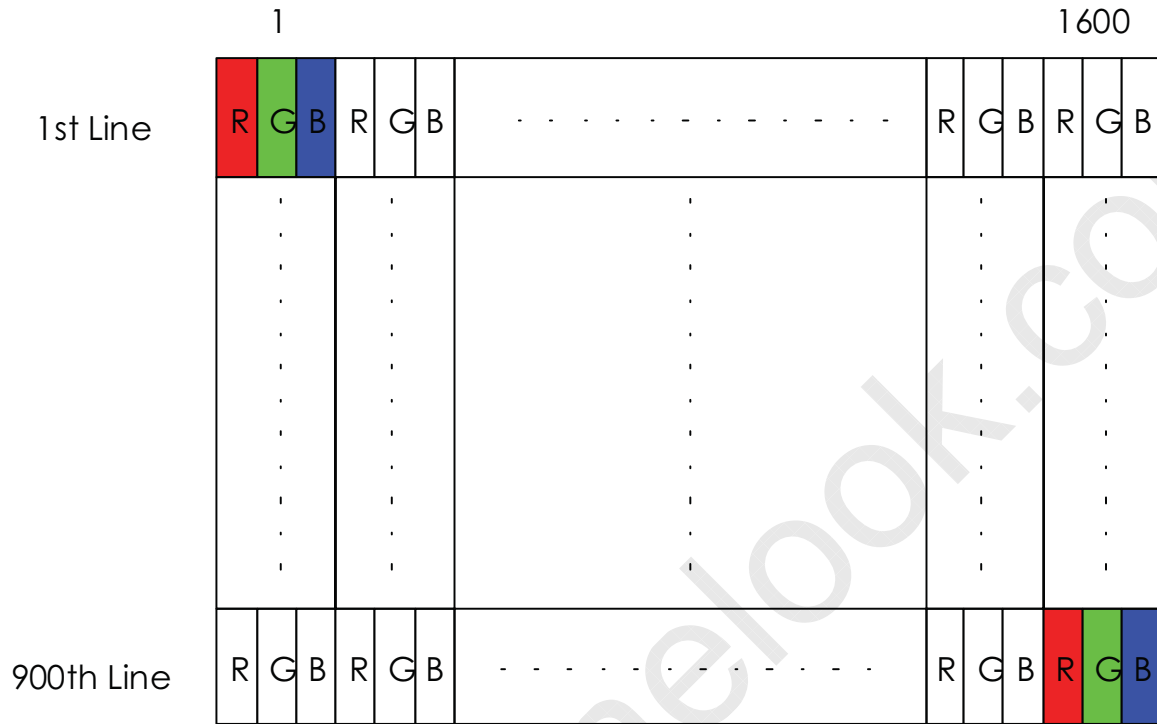



Product Specification

AU OPTRONICS CORPORATION

6.2 The input data format

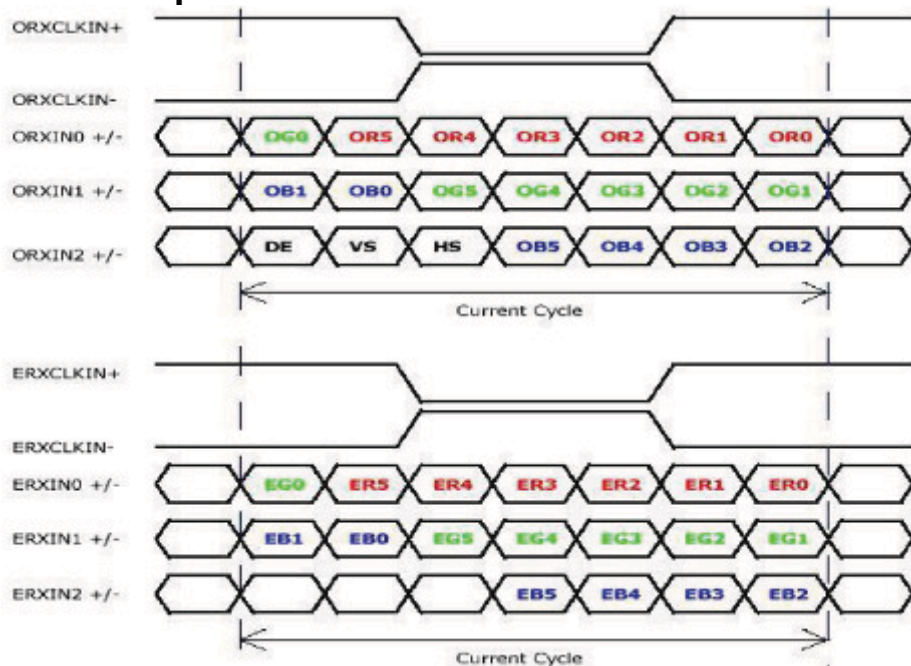

Signal Name	Description	
R5 R4 R3 R2 R1 R0	Red Data 5 (MSB) Red Data 4 Red Data 3 Red Data 2 Red Data 1 Red Data 0 (LSB)	Red-pixel Data Each red pixel's brightness data consists of these 6 bits pixel data.
G5 G4 G3 G2 G1 G0	Green Data 5 (MSB) Green Data 4 Green Data 3 Green Data 2 Green Data 1 Green Data 0 (LSB)	Green-pixel Data Each green pixel's brightness data consists of these 6 bits pixel data.
B5 B4 B3 B2 B1 B0	Blue Data 5 (MSB) Blue Data 4 Blue Data 3 Blue Data 2 Blue Data 1 Blue Data 0 (LSB)	Blue-pixel Data Each blue pixel's brightness data consists of these 6 bits pixel data.
RxCLKIN	Data Clock	The signal is used to strobe the pixel data and DE signals. All pixel data shall be valid at the falling edge when the DE signal is high
DE	Display Timing	This signal is strobed at the falling edge of RxCLKIN. When the signal is high, the pixel data shall be valid to be displayed.
VS	Vertical Sync	The signal is synchronized to RxCLKIN .
HS	Horizontal Sync	The signal is synchronized to RxCLKIN .

Note: Output signals from any system shall be low or High-impedance state when VDD is off.



Product Specification

AU OPTRONICS CORPORATION

6.3 Integration Interface and Pin Assignment

6.3.1 Connector Description

Physical interface is described as for the connector on module.

These connectors are capable of accommodating the following signals and will be following components.

Connector Name / Designation	For Signal Connector
Manufacturer	JAE
Type / Part Number	HD1S040HA1
Mating Housing/Part Number	IPEX 20353-040T-11 (Note 1)

Note1 for reference only

6.3.2 Pin Assignment

LVDS is a differential signal technology for LCD interface and high speed data transfer device.

Pin	Signal	Description
1	NC	No Connection (Reserve)
2	AVDD	PowerSupply,3.3V(typical)
3	AVDD	PowerSupply,3.3V(typical)
4	DVDD	DDC 3.3Vpower
5	NC	No Connection (Reserve for M1 aging)
6	SCL	EDID Clock Input
7	SDA	EDID Data Input
8	Odd_Rin0-	-LVDSdifferential data input(R0-R5,G0)
9	Odd_Rin0+	+LVDS differential data input(R0-R5,G0)
10	GND	Ground
11	Odd_Rin1-	-LVDS differential data input(G1-G5,B0-B1)
12	Odd_Rin1+	+LVDS differential data input(G1-G5,B0-B1)
13	GND	Ground
14	Odd_Rin2-	-LVDS differential data input(B2-B5,HS,VS,DE)
15	Odd_Rin2+	+LVDS differential data input(B2-B5,HS,VS,DE)
16	GND	Ground
17	Odd_ClkIN-	-LVDS differential clock input
18	Odd_ClkIN+	+LVDS differential clock input
19	GND	Ground–Shield
20	Even_Rin0-	-LVDS differential data input(R0-R5,G0)
21	Even_Rin0+	+LVDS differential data input(R0-R5,G0)
22	GND	Ground
23	Even_Rin1-	-LVDS differential data input(G1-G5,B0-B1)
24	Even_Rin1+	+LVDS differential data input(G1-G5,B0-B1)
25	GND	Ground



Product Specification

AU OPTRONICS CORPORATION

26	Even_Rin2-	-LVDS differential data input(B2-B5,HS,VS,DE)
27	Even_Rin2+	+LVDS differential data input(B2-B5,HS,VS,DE)
28	GND	Ground
29	Even_ClkIN-	-LVDS differential clock input
30	Even_ClkIN+	+LVDS differential clock input
31	GND	Ground–Shield
32	VLED_GND	LED Ground
33	VLED_GND	LED Ground
34	NC	No Connection (Reserve)
35	PWM	System PWM Logic Input level
36	LED_EN	LED enable input level
37	NC	No Connection (Reserve)
38	VLED	LED Power Supply (6-21V)
39	VLED	LED Power Supply (6-21V)
40	VLED	LED Power Supply (6-21V)

Note1: Input signals shall be low or High-impedance state when VDD is off.



Product Specification

AU OPTRONICS CORPORATION

6.4 Interface Timing

6.4.1 Timing Characteristics

Basically, interface timings should match the 1600x900 /60Hz manufacturing guide line timing.

Parameter	Symbol	Min.	Typ.	Max.	Unit	
Frame Rate	-	-	60	-	Hz	
Clock frequency	$1/T_{\text{Clock}}$	66.9	72	80	MHz	
Vertical Section	Period	T_V	788	824	900+A	T_{Line}
	Active	T_{VD}	900			
	Blanking	T_{VB}	20	56	A	
Horizontal Section	Period	T_H	1416	1456	800+B	T_{Clock}
	Active	T_{HD}	800			
	Blanking	T_{HB}	50	90	B	

Note : DE mode only

6.4.2 Timing diagram

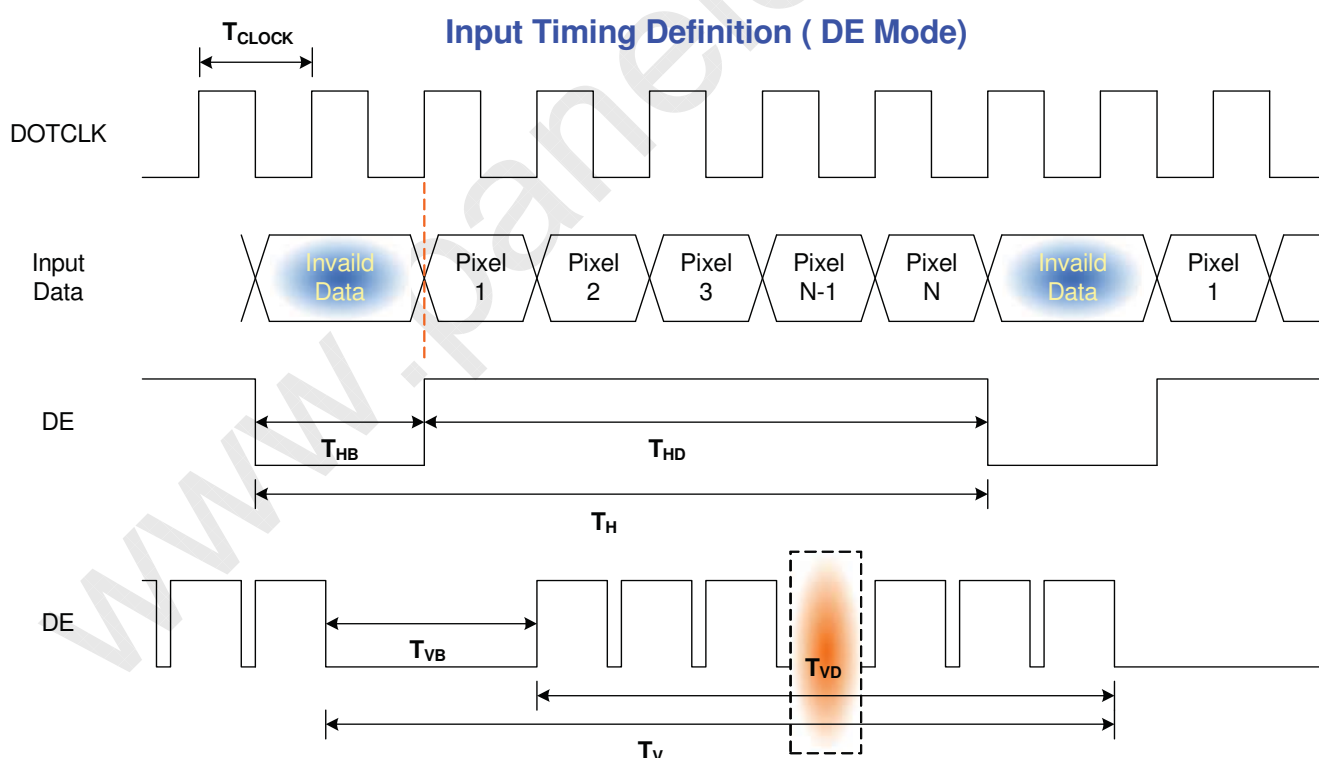



Product Specification

AU OPTRONICS CORPORATION

6.5 Power ON/OFF Sequence

Power on/off sequence is as follows. Interface signals and LED on/off sequence are also shown in the chart. Signals from any system shall be Hi-Z state or low level when VDD is off.

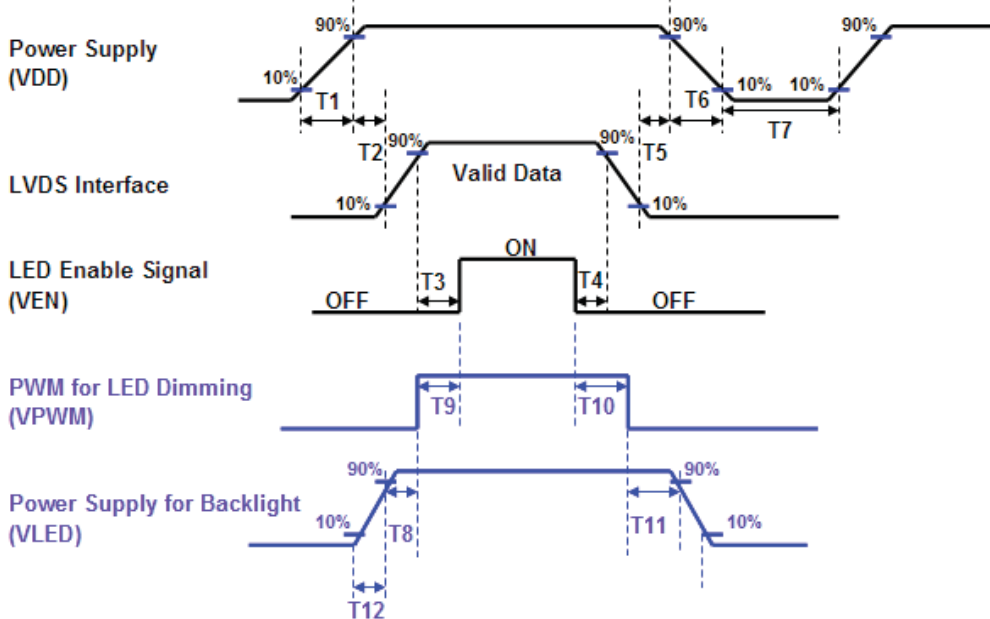

When the adapter is hot plugged, the backlight power supply sequence is shown as below.

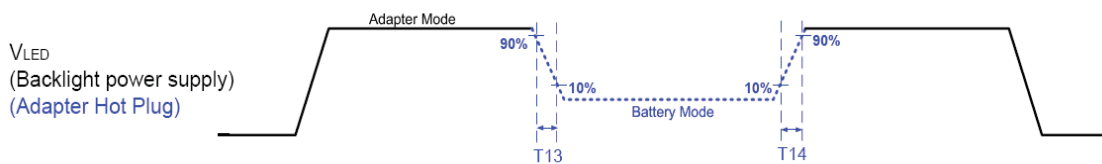

Power Sequence Timing			
Parameter	Value		Units
	Min.	Max.	
T1	0.5	10	ms
T2	0	50	
T3	200	-	
T4	200	-	
T5	0	50	
T6	0	10	
T7	500	-	
T8	10	-	
T9	10	-	
T10	10	-	
T11	10	-	
T12	0.5	10	
T13	1*	-	
T14	1*	-	

*Note : If Seamless

= 5 x T_{PWM} (T_{PWM}= 1/PWM Frequency)

change, T13 & T14



Product Specification

AU OPTRONICS CORPORATION

7. Vibration and Shock Test

7.1 Vibration Test

Test Spec:

- Test method: Non-Operation
- Acceleration: 1.5 G
- Frequency: 10 - 500Hz Random
- Sweep: 30 Minutes each Axis (X, Y, Z)

7.2 Shock Test Spec:

Test Spec:

- Test method: Non-Operation
- Acceleration: 220 G , Half sine wave
- Active time: 2 ms
- Pulse: X,Y,Z .one time for each side

7.3. Reliability

Items	Required Condition	Note
Temperature Humidity Bias	Ta= 40°C, 90%RH, 300h	
High Temperature Operation	Ta= 50°C, Dry, 300h	
Low Temperature Operation	Ta= 0°C, 300h	
High Temperature Storage	Ta= 60°C, 35%RH, 300h	
Low Temperature Storage	Ta= -20°C, 50%RH, 300h	
Thermal Shock Test	Ta=-20°C to 60°C, Duration at 30 min, 100 cycles	
ESD	Contact : ±8 KV Air : ±15 KV	Note 1

Note1: According to EN 61000-4-2 , ESD class B: Some performance degradation allowed. No data lost
. Self-recoverable. No hardware failures.

Remark: MTBF (Excluding the LED): 30,000 hours with a confidence level 90%



Product Specification

AU OPTONICS CORPORATION

8. Mechanical Characteristics

8.1 LCM Outline Dimension

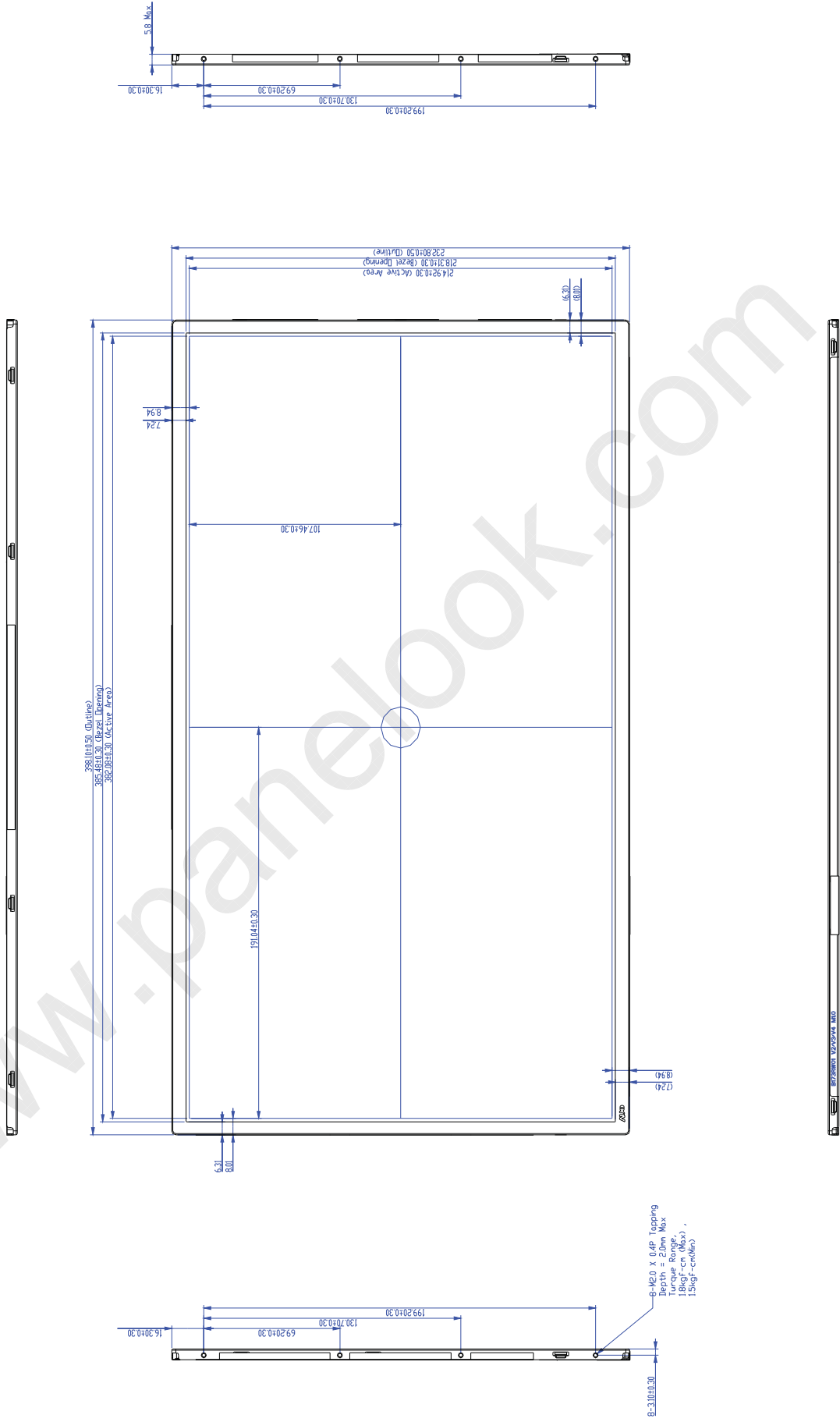



Product Specification

AU OPTRONICS CORPORATION

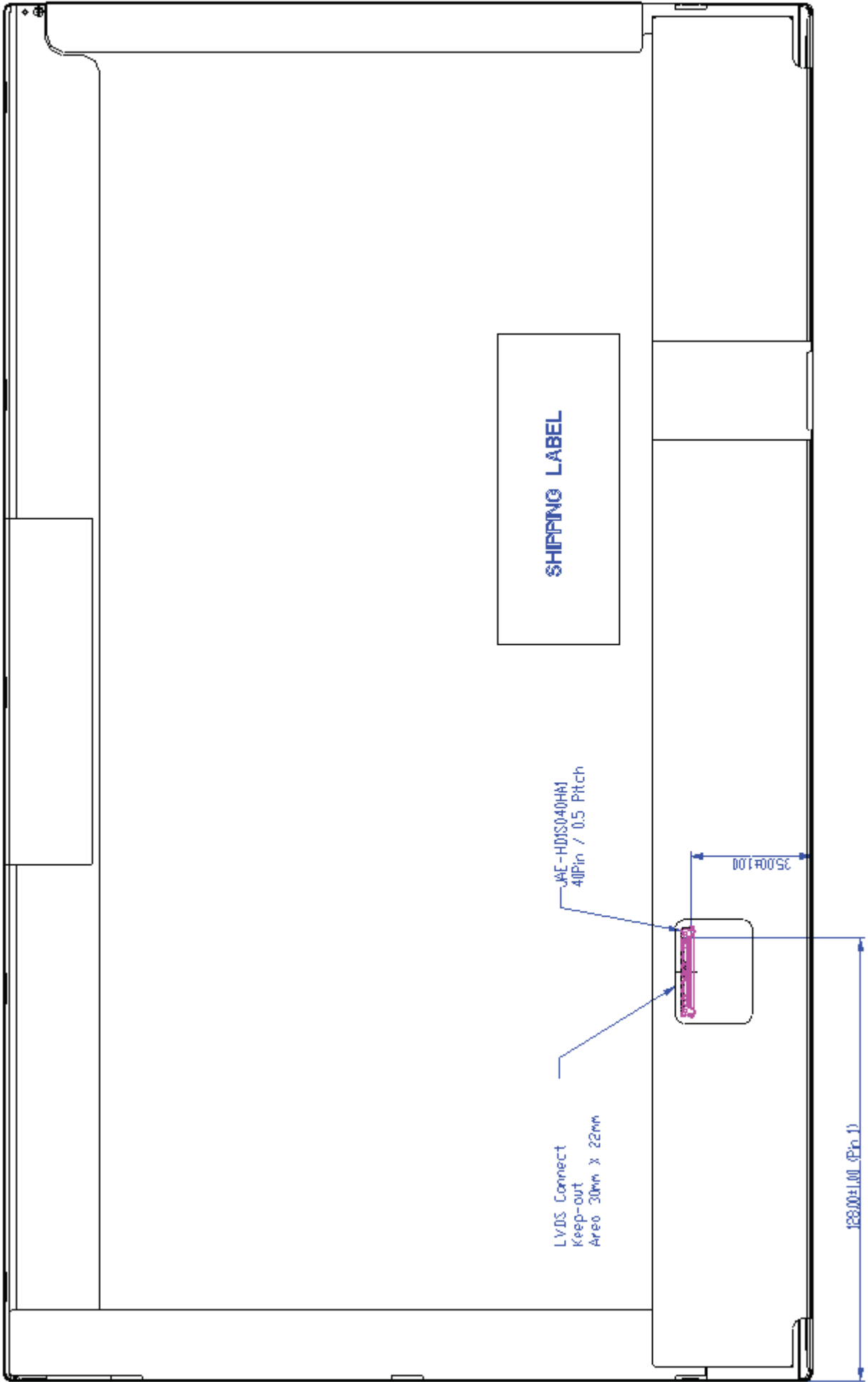

Note: Prevention IC damage, IC positions not allowed any overlap over these areas.



Product Specification

AU OPTRONICS CORPORATION

8.2 Screw Hole Depth and Center Position

Maximum Screw penetration from side surface is 2.5mm (See drawing)

Screw hole center location, from front surface = 3.10 ± 0.3 mm (See drawing)

Screw Torque: Maximum 2.5 kgf-cm

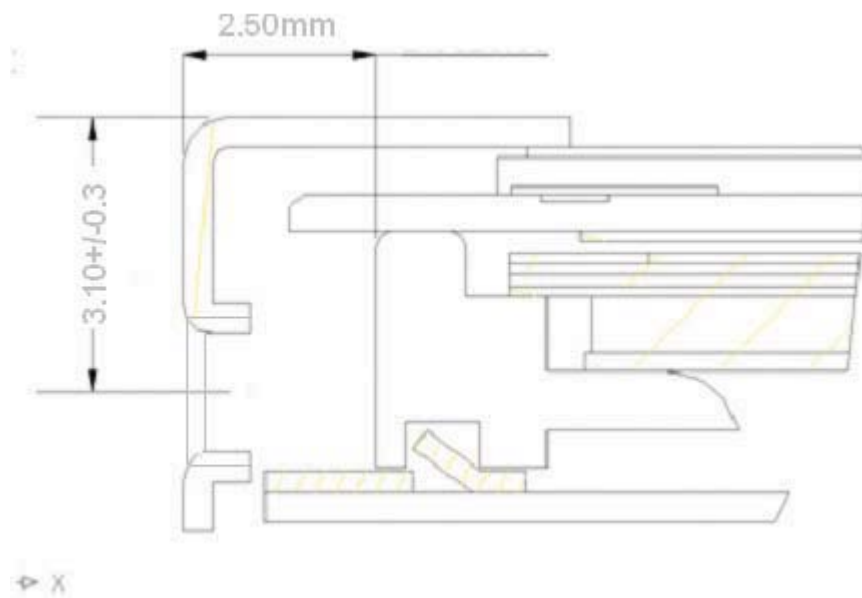



Product Specification

AU OPTRONICS CORPORATION

9. Shipping and Package

9.1 Shipping Label Format





Product Specification

AU OPTRONICS CORPORATION

9.2. Carton package

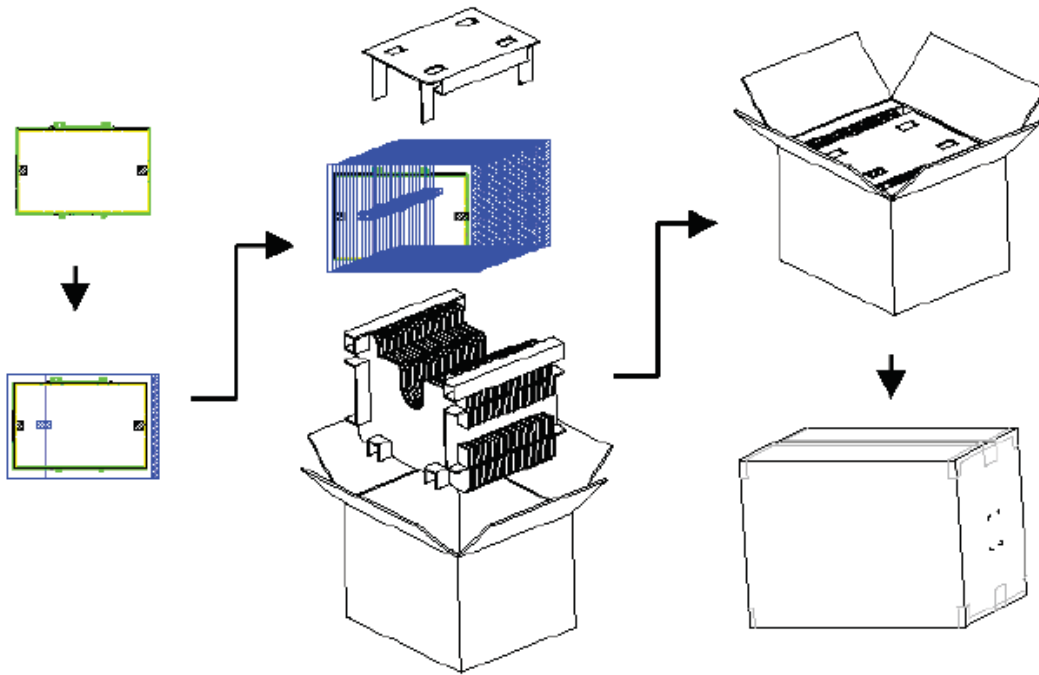

9.3 Shipping package of palletizing sequence

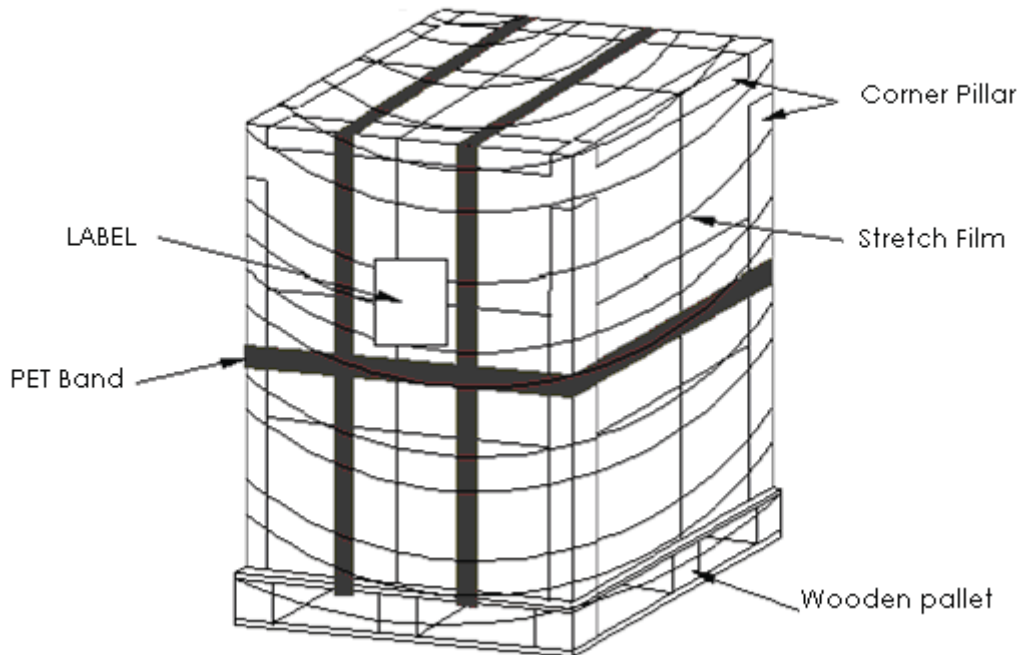



Product Specification

AU OPTRONICS CORPORATION

10. Appendix: EDID description

B173RTN01 2 EDID Code

Address	FUNCTION	Value	Value	Value
HEX		HEX	BIN	DEC
00	Header	00	00000000	0
01		FF	11111111	255
02		FF	11111111	255
03		FF	11111111	255
04		FF	11111111	255
05		FF	11111111	255
06		FF	11111111	255
07		00	00000000	0
08	EISA Manuf. Code LSB	06	00000110	6
09	Compressed ASCII	AF	10101111	175
0A	Product Code	9E	10011110	158
0B	hex, LSB first	12	00010010	18
0C	32-bit ser #	00	00000000	0
0D		00	00000000	0
0E		00	00000000	0
0F		00	00000000	0
10	Week of manufacture	00	00000000	0
11	Year of manufacture	15	00010101	21
12	EDID Structure Ver.	01	00000001	1
13	EDID revision #	04	00000100	4
14	Video input def. (<i>digital I/P, non-TMDS, CRGB</i>)	90	10010000	144
15	Max H image size (<i>rounded to cm</i>)	26	00100110	38
16	Max V image size (<i>rounded to cm</i>)	15	00010101	21
17	Display Gamma (<i>=(gamma*100)-100</i>)	78	01111000	120
18	Feature support (<i>no DPMS, Active OFF, RGB, tmg Blk#1</i>)	02	00000010	2
19	Red/green low bits (Lower 2:2:2:2 bits)	C4	11000100	196
1A	Blue/white low bits (Lower 2:2:2:2 bits)	95	10010101	149
1B	Red x (Upper 8 bits)	9E	10011110	158
1C	Red y/ highER 8 bits	57	01010111	87
1D	Green x	53	01010011	83
1E	Green y	92	10010010	146
1F	Blue x	26	00100110	38
20	Blue y	0F	00001111	15
21	White x	50	01010000	80
22	White y	54	01010100	84
23	Established timing 1	00	00000000	0
24	Established timing 2	00	00000000	0
25	Established timing 3	00	00000000	0
26	Standard timing #1	01	00000001	1
27		01	00000001	1
28	Standard timing #2	01	00000001	1



Product Specification

AU OPTRONICS CORPORATION

29		01	00000001	1
2A	Standard timing #3	01	00000001	1
2B		01	00000001	1
2C	Standard timing #4	01	00000001	1
2D		01	00000001	1
2E	Standard timing #5	01	00000001	1
2F		01	00000001	1
30	Standard timing #6	01	00000001	1
31		01	00000001	1
32	Standard timing #7	01	00000001	1
33		01	00000001	1
34	Standard timing #8	01	00000001	1
35		01	00000001	1
36	Pixel Clock/10000 LSB	1B	00011011	27
37	Pixel Clock/10000 USB	26	00100110	38
38	Horz active Lower 8bits	40	01000000	64
39	Horz blanking Lower 8bits	9A	10011010	154
3A	HorzAct:HorzBlnk Upper 4:4 bits	60	01100000	96
3B	Vertical Active Lower 8bits	84	10000100	132
3C	Vertical Blanking Lower 8bits	1A	00011010	26
3D	Vert Act : Vertical Blanking (upper 4:4 bit)	30	00110000	48
3E	HorzSync. Offset	30	00110000	48
3F	HorzSync.Width	20	00100000	32
40	VertSync.Offset : VertSync.Width	36	00110110	54
41	Horz&Vert Sync Offset/Width Upper 2bits	00	00000000	0
42	Horizontal Image Size Lower 8bits	7E	01111110	126
43	Vertical Image Size Lower 8bits	D6	11010110	214
44	Horizontal & Vertical Image Size (upper 4:4 bits)	10	00010000	16
45	Horizontal Border <i>(zero for internal LCD)</i>	00	00000000	0
46	Vertical Border <i>(zero for internal LCD)</i>	00	00000000	0
47	Signal <i>(non-intr, norm, no stero, sep sync, neg pol)</i>	18	00011000	24
48	Detailed timing/monitor	00	00000000	0
49	descriptor #2	00	00000000	0
4A		00	00000000	0
4B		0F	00001111	15
4C		00	00000000	0
4D		00	00000000	0
4E		00	00000000	0
4F		00	00000000	0
50		00	00000000	0
51		00	00000000	0
52		00	00000000	0
53		00	00000000	0
54		00	00000000	0
55		00	00000000	0
56		00	00000000	0
57		00	00000000	0



Product Specification

AU OPTRONICS CORPORATION

58		00	00000000	0
59		20	00100000	32
5A	Detailed timing/monitor	00	00000000	0
5B	descriptor #3	00	00000000	0
5C		00	00000000	0
5D		FE	11111110	254
5E		00	00000000	0
5F	Manufacture	41	01000001	65
60	Manufacture	55	01010101	85
61	Manufacture	4F	01001111	79
62		0A	00001010	10
63		20	00100000	32
64		20	00100000	32
65		20	00100000	32
66		20	00100000	32
67		20	00100000	32
68		20	00100000	32
69		20	00100000	32
6A		20	00100000	32
6B		20	00100000	32
6C	Detailed timing/monitor	00	00000000	0
6D	descriptor #4	00	00000000	0
6E		00	00000000	0
6F		FE	11111110	254
70		00	00000000	0
71	Manufacture P/N	42	01000010	66
72	Manufacture P/N	31	00110001	49
73	Manufacture P/N	37	00110111	55
74	Manufacture P/N	33	00110011	51
75	Manufacture P/N	52	01010010	82
76	Manufacture P/N	54	01010100	84
77	Manufacture P/N	4E	01001110	78
78	Manufacture P/N	30	00110000	48
79	Manufacture P/N	31	00110001	49
7A	Manufacture P/N	2E	00101110	46
7B	Manufacture P/N	32	00110010	50
7C		20	00100000	32
7D		0A	00001010	10
7E	Extension Flag	00	00000000	0
7F	Checksum	E5	11100101	229