

**Construction**

- Dielectric: Polypropylene film
- Gas-impregnated / dry type
- Concentric winding
- Wave cut
- Extruded round aluminum can with stud
- Provided with ceramic discharge module
- Triple safety system

**Features**

- Self-healing technology
- Naturally air cooled (or forced air cooling)
- Indoor mounting

**Typical applications**

- For Power Factor Correction

**Terminals**

- SIGUT terminals

**Mounting parts**

- Threaded stud at bottom of can  
(max. torque = 10 Nm for M12)

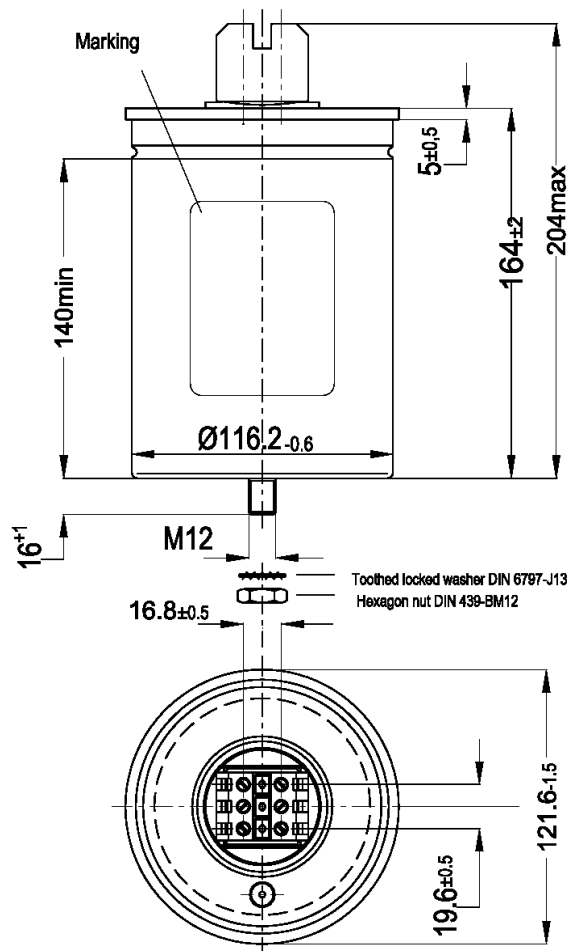
**Dimensional drawing**

All dimensions in mm

**Technical data and specifications**

Characteristics	MKK440-I-8.3-01		MKK525-I-12.5-01	
Rated capacitance $C_R$	1 x 144 $\mu\text{F}$		1 x 144 $\mu\text{F}$	
Tolerance	-5 / +10%		-5 / +10%	
Rated voltage $V_R$	440 VAC		525 VAC	
Rated frequency $f_R$	50 Hz	60 HZ	50 Hz	60 Hz
Output	8.3 kvar	10 kvar	12.5 kvar	15 kvar
Rated current $I_R$	19 A	23 A	24 A	29 A
$\tan\delta$ (dielectric)	0.2 W / kvar		0.2 W / kvar	

Maximum ratings	
$U_{max}$ (up to 8 h daily)	580 VAC
$U_{max}$ (up to 1 min)	680 VAC
$I_{max}$	$1.3 \times I_R$ (A)
$I_S$	$200 \times I_R$ (A)





Test data	
$U_{TT}$	1,150 VAC / 50 Hz during 10 s
$U_{TC}$	3,000VAC / 50 Hz during 10 s
$\tan\delta$ (50 Hz)	$\leq 0.5W / kvar$

Climatic category / -40/D	
$T_{min}$ (-)	40 °C
$T_{max}$ (+)	55 °C
Humidity	av. rel. < 95%
Maximum altitude	4,000 m

Mean life expectancy	
$t_{LD}$	Up to 115,000 hours
Max. 5000 switchings per year acc. to IEC 60831	

Design data	
Dimensions ( $\varnothing \times l$ )	121 x 164 mm
Weight approx	1.5 kg
Impregnation	Dry, inert gas
Fixing	Threaded bolt M12
Max. torque (Al can stud)	10 Nm
Mounting position	Any mounting position possible. See "Maintenance and Installation Manual" for further details.

### Label design

 <b>EPCOS</b> PhaseCap™ MKK525-I-12.5-01	 <b>SIEMENS</b> Power Quality 4RB5 125-5 AA 52
<b>B25667B5147A175</b> $C_N = 1 \times 144 \mu F + 10/- 5\%$ SH $U_N / V$ $Q_N / 50 \text{ Hz}$ $Q_N / 60 \text{ Hz}$ MKK525    12,5 kvar    15,0 kvar MKK440    8,3 kvar    10,0 kvar	
$U_i = 3/- kV$ -40/D Overpressure disconnectors    Dry, inert gas IEC 60831(96)  AFC 10 kA    -40...+55 °C Internally protected CSA C22.2 No.190 Made by EPCOS	
 E 11/05	



<b>Terminals</b>	
Degree of protection	Isolated terminals, IP20
Max. torque	1.2 Nm
Terminal cross section	16 mm <sup>2</sup> (5 AWG)
Maximum terminal current	50 A
Creepage distance	12.7 mm
Clearance	9.6 mm

<b>Safety</b>	
Mechanical safety	Overpressure disconnecter
Max. short circuit current	(AFC: 10 kA)
Discharge resistor time	≤ 1 min (75 V)

<b>Reference Standards</b>
IEC 60831-1/2, UL 810-5th edition
Certification: cUL file E238746

△ Please read information about PFC capacitors and cautions as well as installation and maintenance instructions (Power Factor Correction Product Profile, actual version, and Installation and Maintenance Instructions for PFC-capacitors, available in the Internet) to ensure optimum performance and prevent products from failing, and in worst case, bursting and fire.  
Information given in the PFC-product profile and values given in the data sheet reflect typical specifications. You are kindly requested to approve our product specifications or request our approval for your specification before ordering.

© EPCOS AG 2005. All Rights reserved. Reproduction, publication and dissemination of this data sheet, enclosures hereto and the information contained therein without EPCOS' prior express consent is prohibited. The information contained in this data sheet describes the type of component and shall not be considered as guaranteed characteristics. Purchase orders are subject to the General Conditions for the Supply of Products and Services of the Electrical and Electronics Industry recommended by the ZVEI (German Electrical and Electronic Manufacturers' Association), unless otherwise agreed.