



Revision History

Version	Change Summary	Date	Author
0.10	Created	Dec, 25 th , 13	LY Kuo
0.20	Update Bluetooth Specification Version	Jun, 15 th , 14	LY Kuo

1 System Overview

1.1 General Description

B426-AB1510 is a stereo module, which are highly integrated, cost effective, low power consumptions with Airoha AB1510 chip for intensive audio applications. It complies with Bluetooth system version 4.1 with EDR function. The built-in noise reduction and echo cancellation functions enhance the voice quality. Advanced multipoint supports HFP connection to two handsets for voice, or two A2DP sources for music play back. The voice prompt function can be customized by customers for different voice commands.

1.2 Features

- ò Bluetooth 4.1+EDR compliant
- ò A2DP 1.3 and AVRCP 1.5 profile enable
- ò HFP profile version 1.6 compliant
- ò HSP profile version 1.2 compliant
- ò AVRCP profile version 1.5 compliant
- ò SBC decode
- ò Class 1 or 2 type output power
- ò Support for noise reduction and echo cancellation
- ò Multi-band configurable EQ
- ò Multipoint for HFP and A2DP
- ò Support for voice prompt
- ò Support SPI flash application
- ò Support NFC application with wake-up and pairing function
- ò Audio I/F:I2S and PCM
- ò Integrated Li-ion battery charger supports 400mA fast charging



2 Module Package Information

2.1 Module Pin Definition

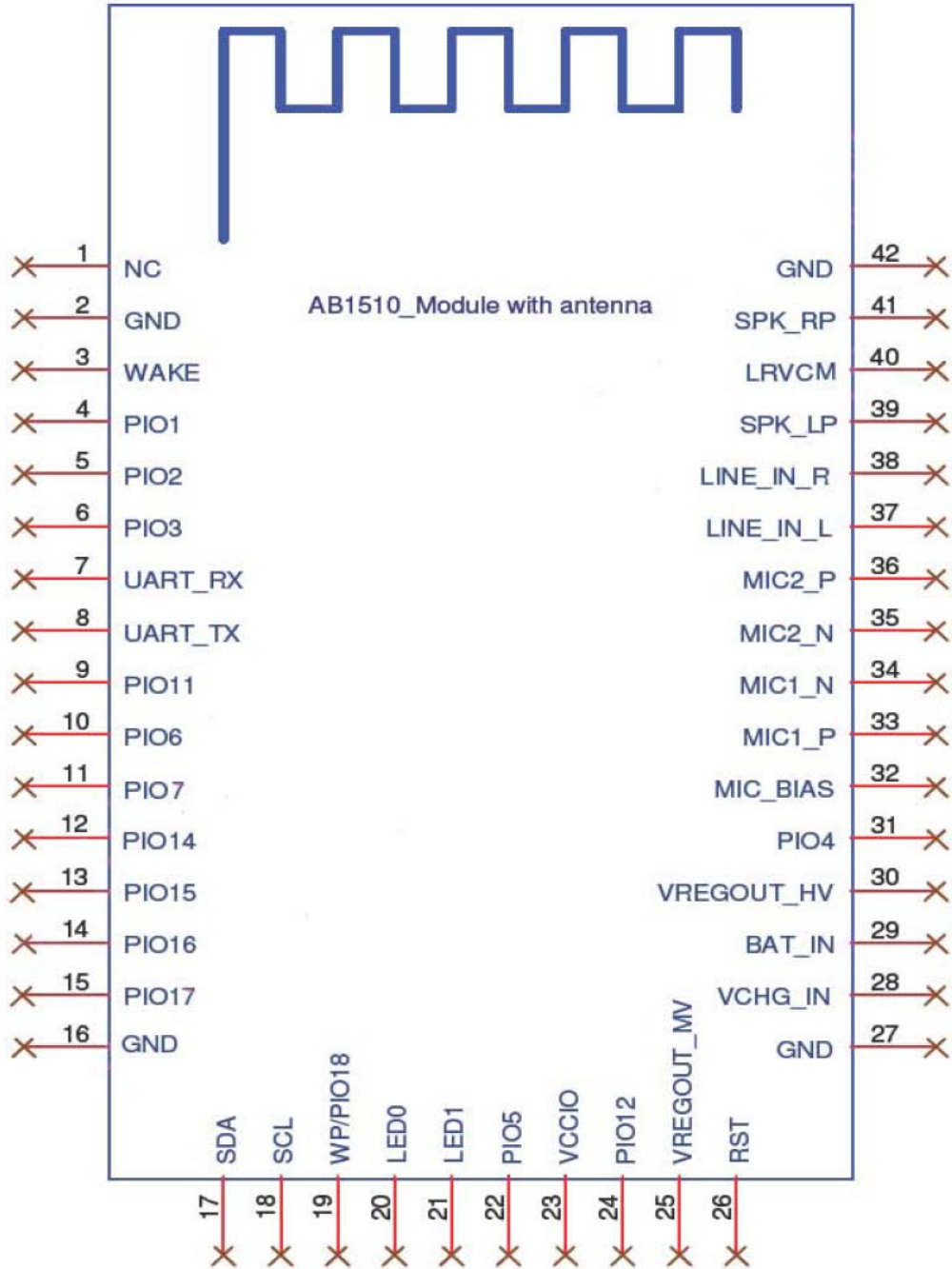

Figure 2-1 Pin Definition



2.2 Pin Description

PIN	SIGNAL	TYPE	DESCRIPTION	ALTERNATIVE
1	NC		NC	
2	GND			
3	WAKE	Input, Digital	Input Pin with 125K pull up	
4	PIO1	Input, Digital	Input Pin with 750K pull up	
5	PIO2	Input, Digital	Input Pin with 750K pull up	
6	PIO3	Input, Digital	Input Pin with 750K pull up	
7	UART_RX	Input, Digital	UART RX	
8	UART_TX	Output, Digital	UART TX	
9	PIO11	Input/Output, Digital	Programmable IO	
10	PIO6	Input/Output, Digital	Programmable IO	
11	PIO7	Input/Output, Digital	Programmable IO	
12	PIO14	Input/Output, Digital	Programmable IO	SPI/PCM/I2S
13	PIO15	Input/Output, Digital	Programmable IO	SPI/PCM/I2S
14	PIO16	Input/Output, Digital	Programmable IO	SPI/PCM/I2S
15	PIO17	Input/Output, Digital	Programmable IO	SPI/PCM/I2S
16	GND			
17	SDA	Input/Output, Digital	I2C data line	
18	SCL	Input/Output, Digital	I2C clock line	
19	WP/PIO18	Output, Digital	Write Protect Control for EEPROM	WP
20	LED0	Open Drain	LED 0 for Red Light	
21	LED1	Open Drain	LED 1 for Blue Light	
		Input/Output, Digital		
22	PIO5	Input/Output, Digital, AIO, Analog	Programmable IO	UART_RTS
23	VCCIO	Supply, 1.8V~3.3V	VCC for IO	
24	PIO12	Input/Output, Digital	Programmable IO	LED3
25	VREGOUT_MV	Analog	LDO output	
26	RST	Input, Digital	Global reset	
27	GND			
28	VCHG_IN	Supply, 5V	VCC for Charger	



PIN	SIGNAL	TYPE	DESCRIPTION	ALTERNATIVE
29	BAT_IN	Supply	Battery input Pas Switching/Linear regulator input	
30	VREGOUT_HV	Analog	LDO output	
31	PIO4	Input/Output.Digital Aio.Analog	Programmable IO	UART_CTS
32	MIC_BIAS	Analog	Microphone bias	
33	MIC1_P	Analog	Microphone 1 P-path	
34	MIC1_N	Analog	Microphone 1 N-path	
35	MIC2_N	Analog	Microphone 2 N-path	
36	MIC2_P	Analog	Microphone 2 P-path	
37	LINE_IN_L	Analog	Line in L-path	
38	LINE_IN_R	Analog	Line in R-path	
39	SPK_LP	Analog	Speaker output LP	
40	LRVCM	Analog	Speaker output LRVCM	
41	SPK_RP	Analog	Speaker output RP	
42	GND			

Table 2-1 Pin Description

2.3 Module package and PCB footprint dimensions

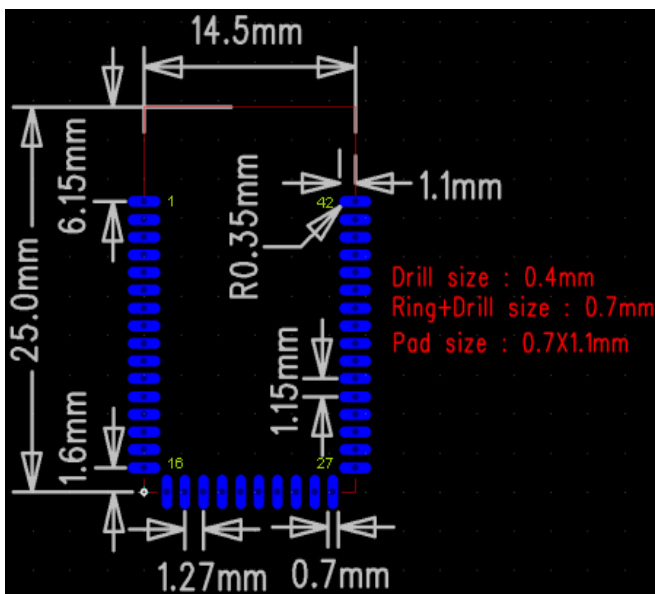

Figure 2-2 Module package dimensions
Dimension:25mm(L)x14.5mm(W)x0.8mm(H)

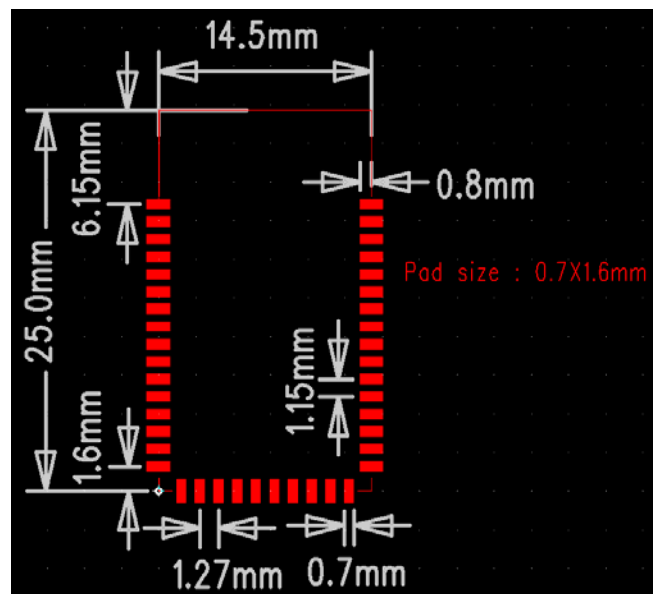
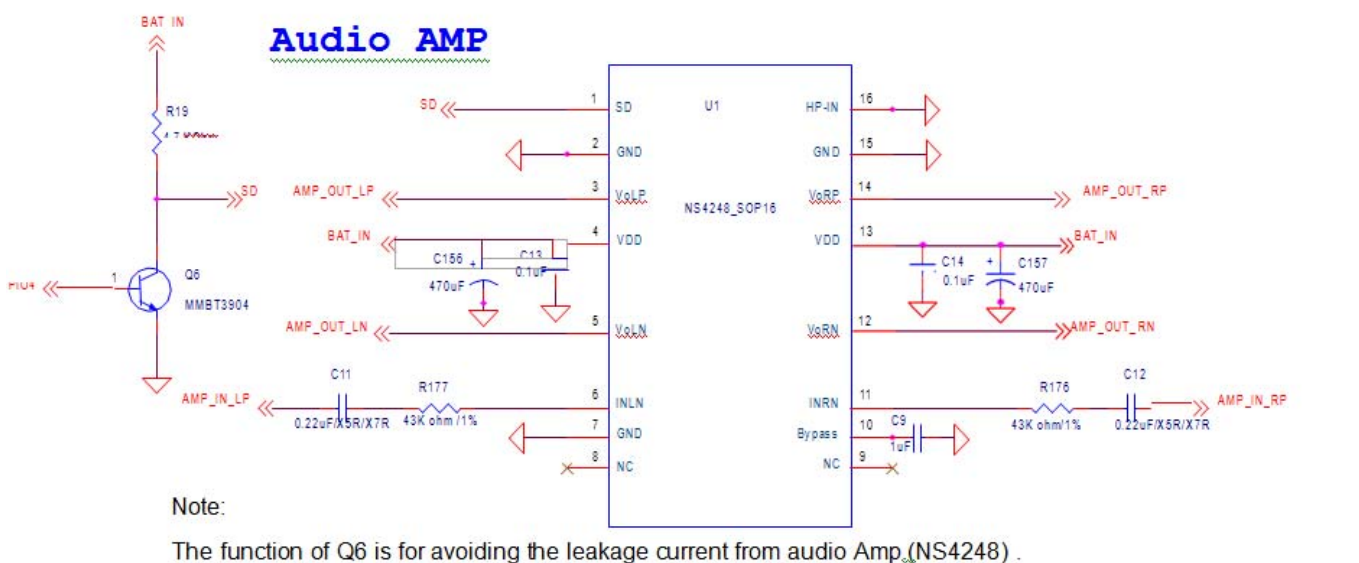
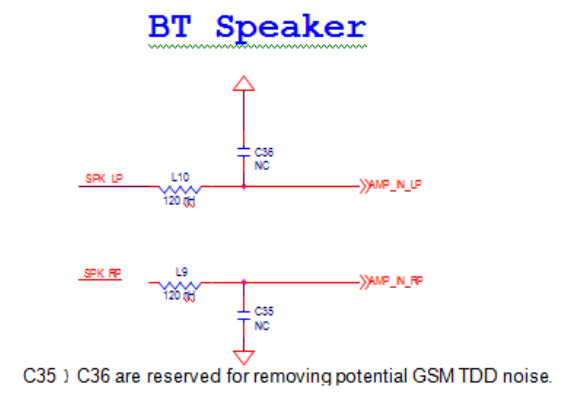
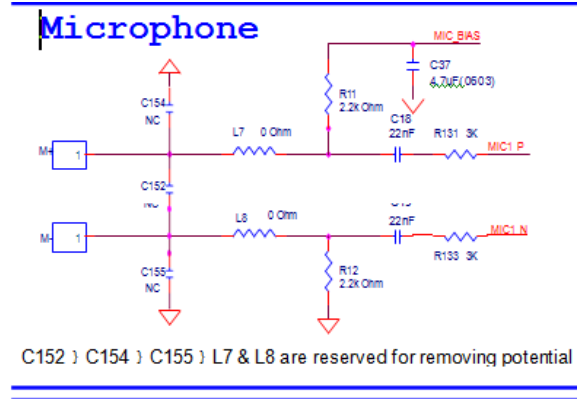
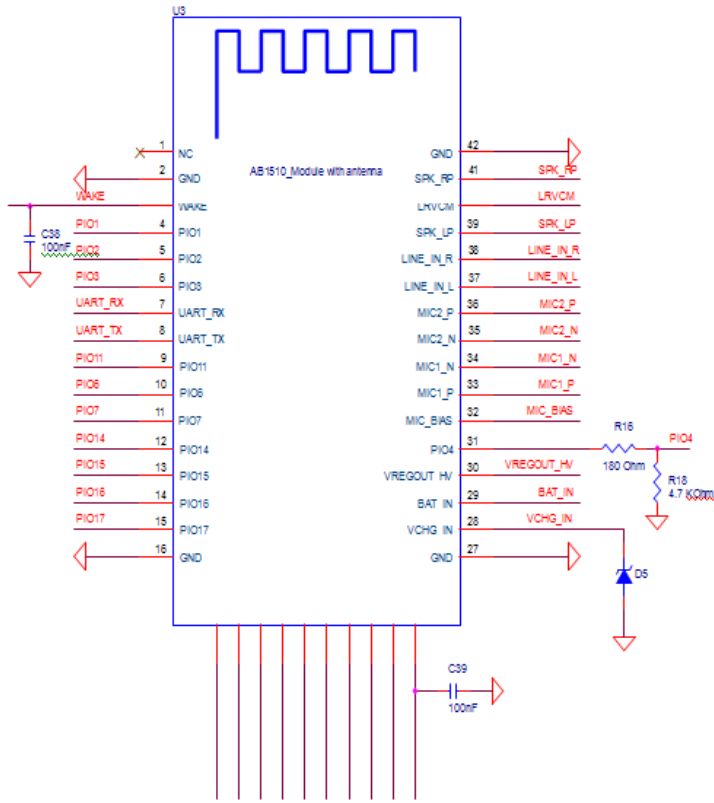
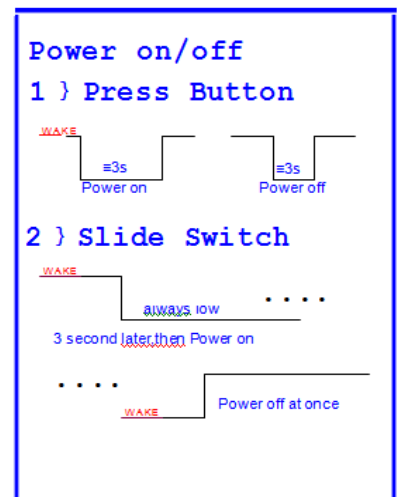
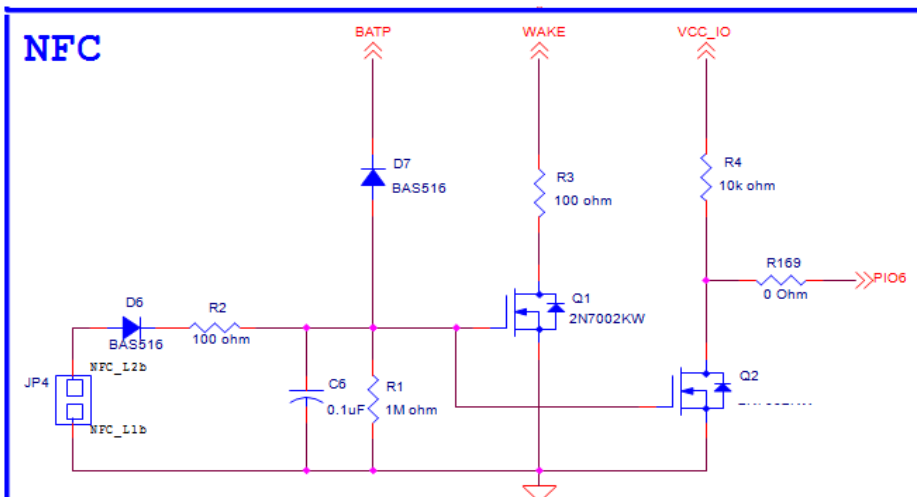
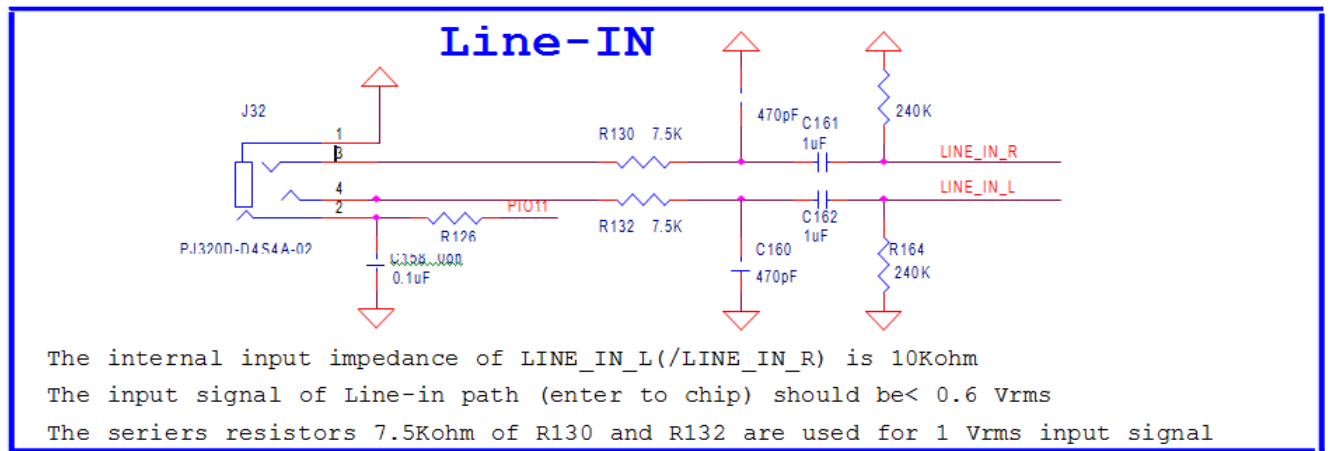
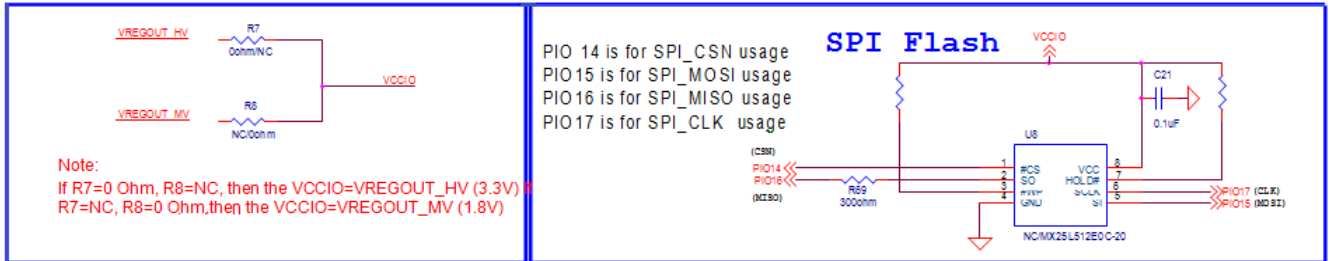

Figure 2-3 Module PCB footprint dimensions



3 General Application Schematic





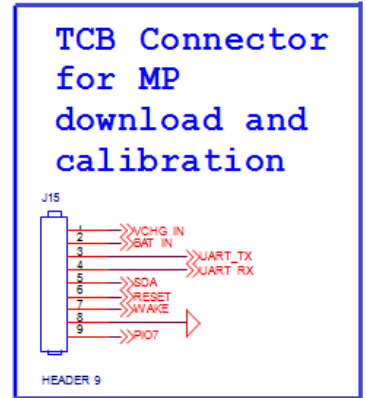
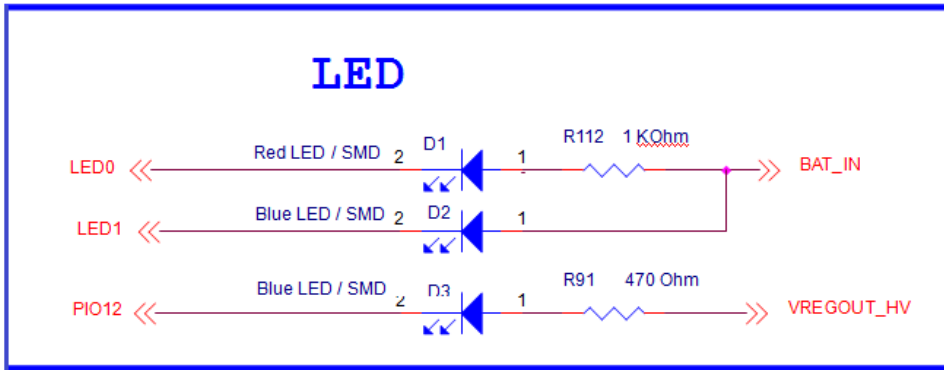

Conditional Hardware Reset

Under the condition of pressing PIO1 to Low, then plug battery charger

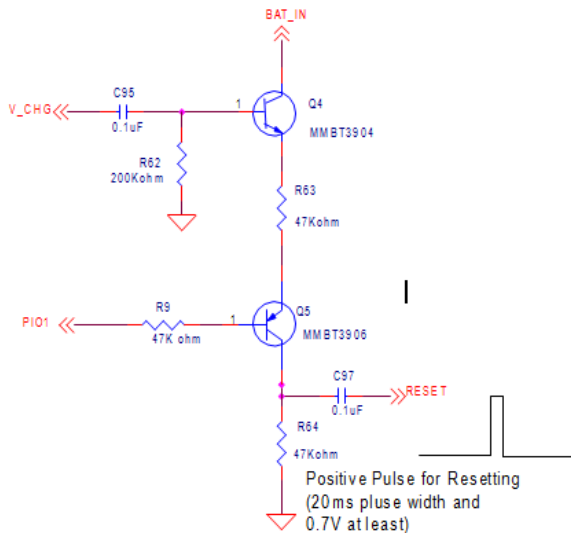

Charger

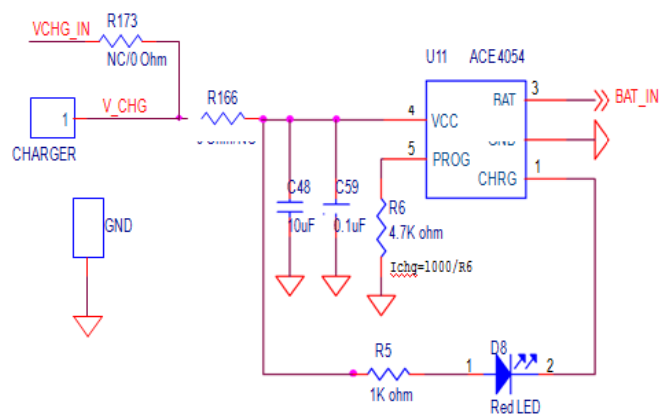

R173=0 Ohm, R166=NC --> Internal charger
 R173=NC, R166=0 Ohm --> External charger



4 Electrical Characteristics

4.1 Recommended Operating Conditions

Item	Min.	Typ.	Max.	Unit
I/O supply voltage (VCCIO)	1.7		3.6	V
Battery supply voltage (BAT_P)	2.7		4.2	V
Internal charger supply voltage (V_CHG)	4.5	5	6.5	V

Table 4-1 Recommended Operating Conditions

4.2 Power

4.2.1 High-Voltage LDO (VREGOUT_HV)

Item	Condition Min.	Min.	Typ.	Max.	Unit
Input Voltage (BAT_P)		2.7		4.2	V
Output Voltage	Input voltage > 3.3V		3		V
Rated Output Current (Iout)	Input voltage = 4.2V		300		mA

Table 4-2 High-Voltage LDO

4.2.1 Medium Voltage LDO (VREGOUT_HV)

Item	Condition Min.	Min.	Typ.	Max.	Unit
Input Voltage (BAT_P)		2.7		4.2	V
Output Voltage			1.8		V
Rated Output Current (Iout)	Input voltage = 4.2V			100	mA

Table 4-3 Medium-Voltage LDO



4.3 Battery Charger

Item	Min.	Typ.	Max.	Unit
Input Voltage	4.5	5	6.5	V
Charge Current (CC Mode)	25		400	mA
Trickle Charge Current		4		mA
Trickle Charge Threshold Voltage		2.92		V
Regulated Output (Float) Voltage		4.2		V

Table 4-4 Battery Charger

4.4 Radio Characteristics

4.4.1 Transmitter

Basic Data Rate

Core Supply Voltage = 1.8V @ 25°C

Item	Min.	Typ.	Max.	Unit
Maximum RF transmit Power*1		7		dBm
RF power control range		25		Db
20dB bandwidth for modulated carrier		900		KHz
Adjacent channel transmit power	+2MHz		-20	dBm
	-2MHz		-20	dBm
	+3MHz		-40	dBm
	-3MHz		-40	dBm
Frequency deviation	Δf_{1avg} Maximum Modulation	165		KHz
	Δf_{2max} Minimum Modulation	140		KHz
	$\Delta f_{1avg}/\Delta f_{2avg}$	0.9		
Initial carrier frequency tolerance	-75		75	KHz
Freq. Drift	DH1 packet	-25	25	KHz
	DH3 packet	-40	40	KHz
	DH5 packet	-40	40	KHz
Freq. Drift Rate	-20		20	KHz/50us
Harmonic Content		-45		dBm

Table 4-5 Transmitter Basic Data Rate



Enhanced Data Rate

Core Supply Voltage = 1.8V @ 25°C

Item	Min.	Typ.	Max.	Unit
Relative transmit power		-1.5		dB
$\pi/4$ DQPSK max carrier frequency stability $ \omega_o $	-10		10	KHz
$\pi/4$ DQPSK max carrier frequency stability $ \omega_i $	-75		75	KHz
$\pi/4$ DQPSK max carrier frequency stability $ \omega_o+\omega_i $	-75		75	KHz
8DPSK max carrier frequency stability $ \omega_o $	-10		10	KHz
8DPSK max carrier frequency stability $ \omega_i $	-75		75	KHz
8DPSK max carrier frequency stability $ \omega_o+\omega_i $	-75		75	KHz
$\pi/4$ DQPSK Modulation Accuracy	RMS DEVM		20	%
	99% DEVM	99		%
	Peak DEVM		35	%
8DPSK Modulation Accuracy	RMS DEVM		13	%
	99% DEVM	99		%
	Peak DEVM		25	%
In-band spurious emissions	$F > F_0 + 3\text{MHz}$		-40	dBm
	$F < F_0 - 3\text{MHz}$		-40	dBm
	$F = F_0 + 3\text{MHz}$		-40	dBm
	$F = F_0 - 3\text{MHz}$		-40	dBm
	$F = F_0 + 2\text{MHz}$		-20	dBm
	$F = F_0 - 2\text{MHz}$		-20	dBm
	$F = F_0 + 1\text{MHz}$		-26	dB
	$F = F_0 - 1\text{MHz}$		-26	dB
EDR Differential Phase Encoding	99			%

Table 4-6 Transmitter Enhanced Data Rate



4.4.2 Receiver

Basic Data Rate

Core Supply Voltage = 1.35V @ 25°C

Item		Min.	Typ.	Max.	Unit
Sensitivity at 0.1% BER	2.402GHz		-92		dBm
	2.441GHz		-92		dBm
	2.480GHz		-92		dBm
Maximum input power at 0.1% BER		-20			dBm
Co-Channel interference				11	dB
Co-Channel interference C/I	F = F0+1MHz			0	dB
	F = F0-1MHz			0	dB
	F = F0+2MHz			-30	dB
	F = F0-2MHz			-20	dB
	F = F0+3MHz			-40	dB
	F = Fimage			-9	dB
Maximum level of intermodulation interference		-39			dBm
Blocking @Pin=-67dBm with 0.1%BER	30-2000 MHz	-10			dBm
	2000-2400 MHz	-27			dBm
	2500-3000 MHz	-27			dBm
	3000-12750 MHz	-10			dBm

Table 4-7 Receiver Basic Data Rate



Enhanced Data Rate

Core Supply Voltage = 1.8V @ 25°C

Item		Min.	Typ.	Max.	Unit	
Sensitivity at 0.01% EDR	$\pi/4$ DQPSK		-91		dBm	
	8DPSK		-83		dBm	
Maximum input power at 0.1% BER	$\pi/4$ DQPSK	-20			dBm	
	8DPSK	-20			dBm	
Co-Channel interference	$\pi/4$ DQPSK			13	dB	
	8DPSK			21	dB	
Adjacent channel selectivity C/I	F = F ₀ +1MHz	$\pi/4$ DQPSK			0	dB
		8DPSK			5	dB
	F = F ₀ -1MHz	$\pi/4$ DQPSK			0	dB
		8DPSK			5	dB
	F = F ₀ +2MHz	$\pi/4$ DQPSK			-30	dB
		8DPSK			-25	dB
	F = F ₀ -2MHz	$\pi/4$ DQPSK			-20	dB
		8DPSK			-13	dB
	F = F ₀ +3MHz	$\pi/4$ DQPSK			-40	dB
		8DPSK			-33	dB
	F = F _{image}	$\pi/4$ DQPSK			-7	dB
		8DPSK			0	dB

Table 4-8 Receiver Enhanced Data Rate



4.5 Audio ADC

Item	Condition	Min.	Typ.	Max.	Unit
SNR	Microphone amplifier (A-Weighted 1kHz@ full scale, microphone input BW=20~20kHz)		84		dB
	Codec bypass mode (A-Weighted 1kHz@ full scale, line-input BW=20~20kHz, VCCSPK=3V EAR_AMP=0dB)		95		dB
THD+N	Microphone amplifier gain=42dB (A-Weighted 1kHz@-10dBFS, microphone input BW=20~4kHz)			-55	dB
	Microphone amplifier gain=21dB (A-Weighted 1kHz@-10dBFS,microphone input BW=20~20kHz)		-66.7		dB
	Microphone amplifier gain=0dB (A-Weighted 1kHz@ -10dBFS,line-input BW=20~20kHz)		0.05		%
Digital Gain		-21		24	dB
Analog Gain		0		42	dB
Input Full-Scale at MAX gain			2.24		MVrms
Input Full-Scale at Min gain			282		MVrms
Microphone in level	(Microphone input, full scale)			0.8	Vpp
Input in level	(Line-input, full scale)			1.7	Vpp
Mic_bias_voltage			2.7		V

Table 4-9 Audio ADC



4.6 Stereo DAC

Item	Condition	Min.	Typ.	Max.	Unit
SNR			94		dB
THD+N	16 ohm load Analog gain=0dB			0.1	%
Output swing	SPK_LP or SPK_RP Output Full-Scale at load=16Ohm SPK_RP -- (16Ohm) LRVCM SPK_LP -- (16Ohm) speaker gain=3dB		2.1		Vpp
Digital Gain		-21		24	dB
Analog Gain		-12		9	dB
Allow load	VCCSPK=3V	8	16		Ohm
Cross talk	Load =16Ohm		-50		dB
Noise floor power	Analog gain=0dB		-100		Dbv

Table 4-10 Stereo DAC