



Aluminum electrolytic capacitors

Capacitors with multi-pin terminals

Series/Type: B43613

Date: November 2024

Long-life grade capacitors

Applications

- Frequency converters
- Solar inverters
- Uninterruptible power supplies
- Professional power supplies
- Not for automotive applications unless otherwise specified

Features

- High volumetric efficiency
- High ripple current capability
- Pinning ensures correct insertion
- Diffusion vent
- RoHS-compatible

Construction

- Charge/discharge-proof, polar
- Aluminum case, covered with PET sleeve without insulation sheet at the can bottom
- Version with additional PET insulation cap on terminal side and PVC sleeve available for insulating the capacitor from the PCB
- Version with PVC sleeve available upon request
- Overload protection by pressure relief vent on the base

Terminals

- 4-pin snap-in terminals (6.3 mm and 4.5 mm length) for diameter 40 to 45 mm
- 5-pin snap-in terminals (6.3 mm and 4.5 mm length) for diameter 50 mm



Specifications and characteristics in brief

Rated voltage V_R Surge voltage V_S	400 ... 550 V DC $1.10 \cdot V_R$		
Rated capacitance C_R Capacitance tolerance	270... 3300 μ F $\pm 20\% \triangleq M$		
Dissipation factor $\tan \delta$ (20 °C, 120 Hz)	for case diameter 40 ... 45 mm: $V_R \leq 450$ V DC: $\tan \delta < 0.15$ $V_R \geq 500$ V DC: $\tan \delta < 0.20$ for case diameter 50 mm: $\tan \delta < 0.20$		
Leakage current I_{leak} (5 min, 20 °C)	$I_{leak} \leq 0.3 \mu A \cdot \left(\frac{C_R}{\mu F} \cdot \frac{V_R}{V} \right)^{0.7} + 4 \mu A$		
Self-inductance ESL	Approx. 20 nH		
Useful life ¹⁾ 105 °C; V_R ; $I_{AC,R}$	> 5000 h (400 V ... 500 V) > 3000 h (550 V)	Requirements: $ \Delta C/C \leq 20\%$ of initial value $\tan \delta \leq 2$ times initial specified limit $I_{leak} \leq$ initial specified limit	
Voltage endurance test 105 °C; V_R	2000 h	Post test requirements: $ \Delta C/C \leq 10\%$ of initial value $\tan \delta \leq 1.3$ times initial specified limit $I_{leak} \leq$ initial specified limit	
Vibration resistance test	To IEC 60068-2-6, test Fc: Frequency range 10 ... 55 Hz, displacement amplitude 0.35 mm, acceleration max. 5 g, duration 3 × 2 h. Capacitor mounted by its body which is rigidly clamped to the work surface.		
Characteristics at low temperature	Max. impedance ratio at 100 Hz	V_R	≤ 450 V ≥ 500 V
		$Z_{-25\text{ °C}} / Z_{20\text{ °C}}$	5 7
		$Z_{-40\text{ °C}} / Z_{20\text{ °C}}$	14 20
IEC climatic category	To IEC 60068-1:2013: 40/105/56 (−40°C/+105°C/56 days damp heat test): 400V, 450V 25/105/56 (−25°C/+105°C/56 days damp heat test): 500V, 550V The capacitors can be operated in the temperature range of −40 °C to +105 °C but the impedance at −40 °C must be taken into consideration.		
Sectional specification	IEC 60384-4:2016		

1) Refer to chapter "General technical information, 5 Useful life" on how to interpret useful life.

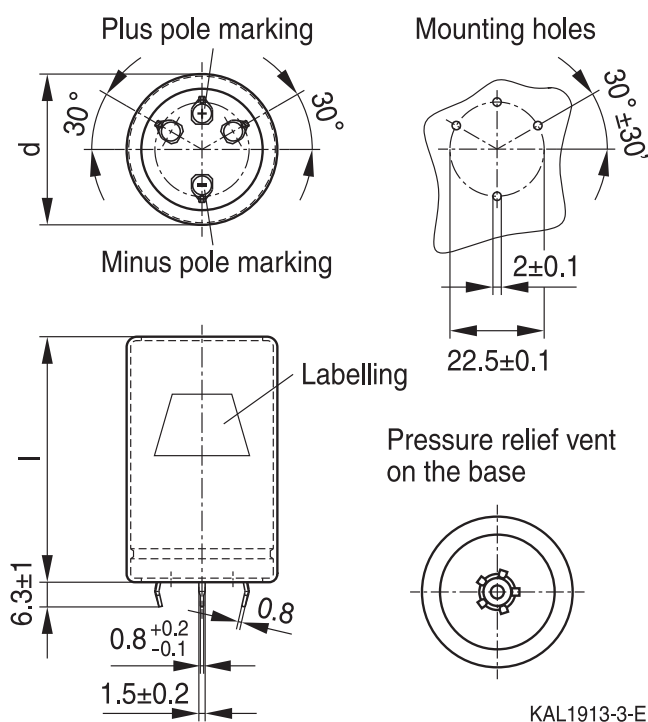
Dimensional drawings
4-pin snap-in terminals with PET sleeve

Standard snap-in terminals: length 6.3 ± 1 mm.

Also available with a length of $4.5 - 1$ mm.

All pin holes must be drilled into the PC-board, since the unconnected pins serve as mountings.

These pins must be soldered to insulated pads or pads with the same potential as the negative pole.

Dimensions and packing units

Dimensions (mm)		Approx. weight (g)	Packing units (pcs.)
d +1	l ±2		
40	40	78	33
40	45	88	33
40	50	98	33
40	55	108	33
40	60	118	33
40	65	128	33
40	70	138	33
40	75	148	33
40	80	158	33
40	85	168	33
40	90	178	33
40	95	188	33
40	100	198	33
40	105	208	33

Dimensions (mm)		Approx. weight (g)	Packing units (pcs.)
d +1	l ±2		
45	40	114	28
45	45	128	28
45	50	141	28
45	55	154	28
45	60	167	28
45	65	181	28
45	70	194	28
45	75	207	28
45	80	221	28
45	85	234	28
45	90	247	28
45	95	260	28
45	100	274	28
45	105	287	28

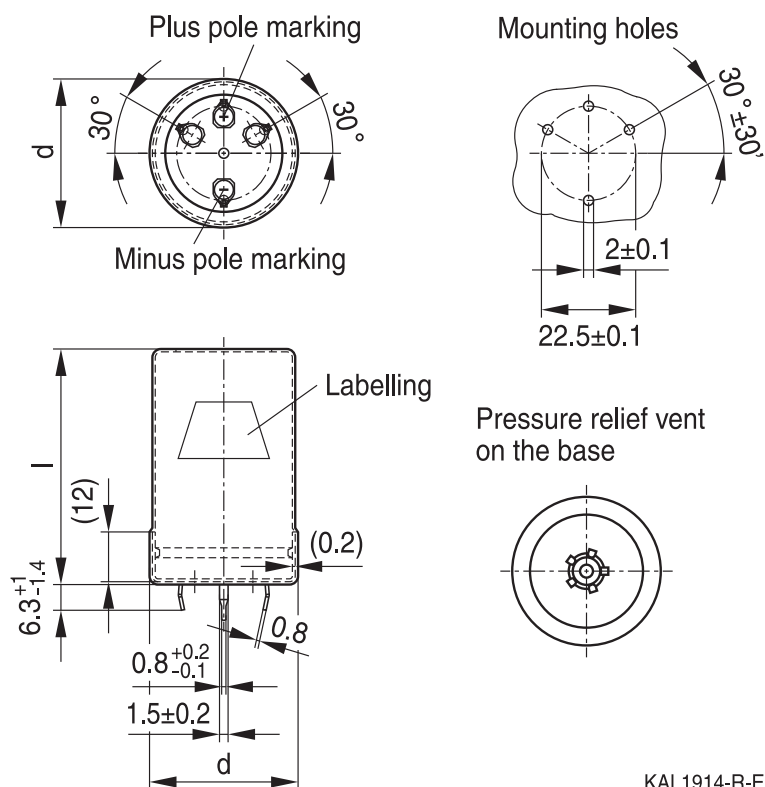
4-pin snap-in terminals, PVC sleeve and PET insulation cap on terminal side

Standard snap-in terminals: length $6.3 +1/-1.4$ mm.

Also available with a length of $4.5 -1.4$ mm. PET insulation cap is positioned under the PVC sleeve.

All pin holes must be drilled into the PC-board, since the unconnected pins serve as mountings.

These pins must be soldered to insulated pads or pads with the same potential as the negative pole.

Dimensions and packing units

Dimensions (mm)		Approx. weight (g)	Packing units (pcs.)
d +1.4	l +2.2/-2		
40	40	78	33
40	45	88	33
40	50	98	33
40	55	108	33
40	60	118	33
40	65	128	33
40	70	138	33
40	75	148	33
40	80	158	33
40	85	168	33
40	90	178	33
40	95	188	33
40	100	198	33
40	105	208	33

Dimensions (mm)		Approx. weight (g)	Packing units (pcs.)
d +1.4	l +2.2/-2		
45	40	114	28
45	45	128	28
45	50	141	28
45	55	154	28
45	60	167	28
45	65	181	28
45	70	194	28
45	75	207	28
45	80	221	28
45	85	234	28
45	90	247	28
45	95	260	28
45	100	274	28
45	105	287	28

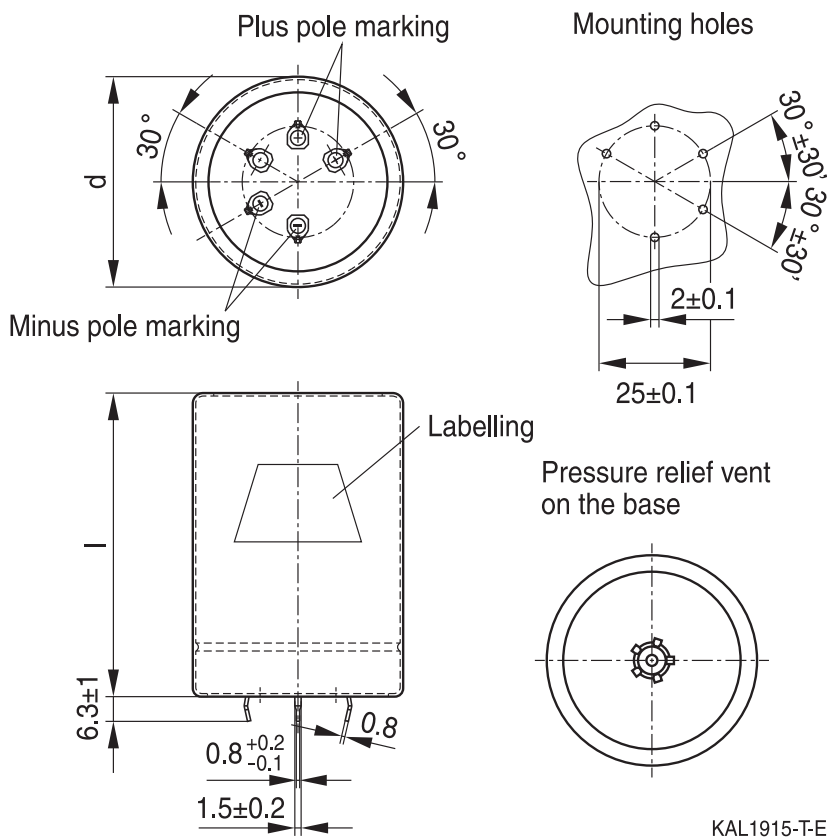
5-pin snap-in terminals with PET sleeve

Standard snap-in terminals: length 6.3 ± 1 mm.

Also available with a length of $4.5 - 1$ mm.

All pin holes must be drilled into the PC-board, since the unconnected pins serve as mountings.

These pins must be soldered to insulated pads or pads with the same potential as the negative pole.

Dimensions and packing units

Dimensions (mm)		Approx. weight (g)	Packing units (pcs.)
d +1	l ±2		
50	40	126	28
50	45	144	28
50	50	162	28
50	55	179	28
50	60	197	28
50	65	215	28
50	70	233	28

Dimensions (mm)		Approx. weight (g)	Packing units (pcs.)
d +1	l ±2		
50	75	251	28
50	80	269	28
50	85	287	28
50	90	304	28
50	95	322	28
50	100	340	28
50	105	358	28

5-pin snap-in terminals, PVC sleeve and PET insulation cap on terminal side

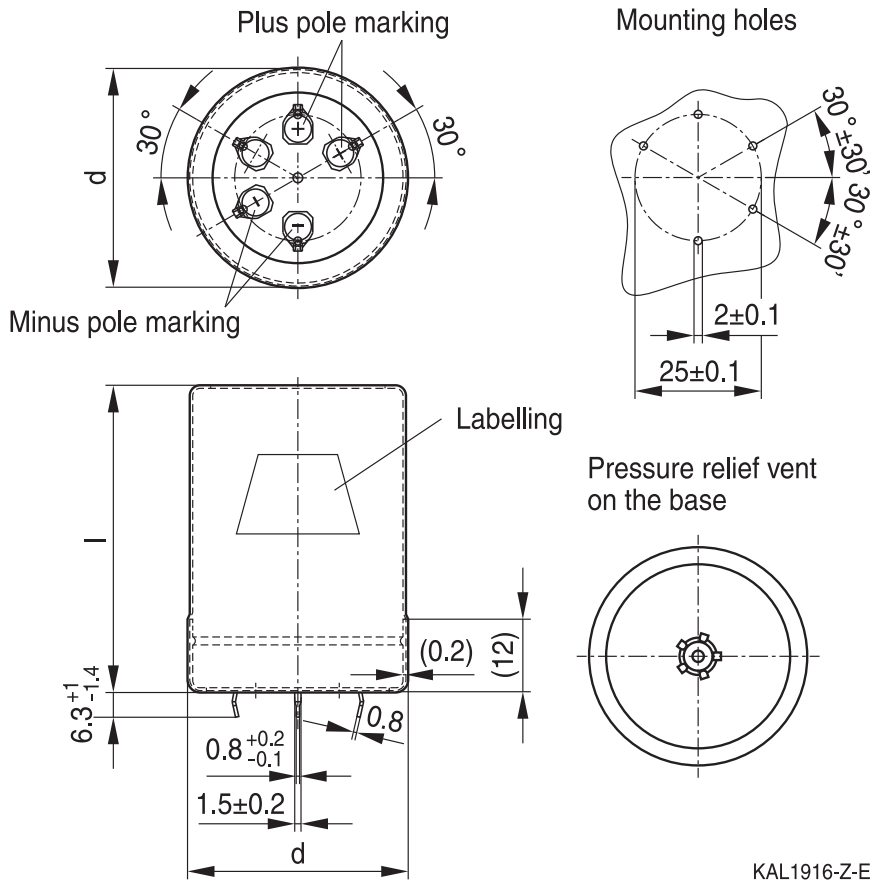

Standard snap-in terminals: length 6.3 +1/1.4 mm.

Also available with a length of 4.5 –1.4 mm.

PET insulation cap is positioned under the PVC sleeve.

All pin holes must be drilled into the PC-board, since the unconnected pins serve as mountings.

These pins must be soldered to insulated pads or pads with the same potential as the negative pole.

Dimensions and packing units

Dimensions (mm)		Approx. weight (g)	Packing units (pcs.)
d +1.4	l +2.2/-2		
50	40	126	28
50	45	144	28
50	50	162	28
50	55	179	28
50	60	197	28
50	65	215	28
50	70	233	28

Dimensions (mm)		Approx. weight (g)	Packing units (pcs.)
d +1.4	l +2.2/-2		
50	75	251	28
50	80	269	28
50	85	287	28
50	90	304	28
50	95	322	28
50	100	340	28
50	105	358	28

Packaging of 4-/5-pin snap-in terminal capacitors



For ecological reasons the packing is pure cardboard.

Ordering codes for terminal styles and insulation features

Identification in 3rd block of ordering code

4-/5-pin snap-in terminal capacitors

Terminal version	Insulation version	
	PET sleeve	PVC sleeve plus PET cap
Standard terminals 6.3 mm	M050	M070
Short terminals 4.5 mm	M057	M077

Ordering examples:

- B43613A9278M057 } 4-pin snap-in capacitor with short terminals and PET sleeve
- B43613A9338M070 } 5-pin snap-in capacitor with standard terminals and PVC sleeve with additional PET insulation cap on terminal side

Overview of available types

The capacitance and voltage ratings listed below are available in different case sizes upon request.

Other voltage and capacitance ratings are also available upon request.

Capacitors with 50 mm case diameter are only available with 5-pin snap-in terminals.

V_R (V DC)	400	450	500	550
	Case dimensions d x l (mm)			
C_R (μF)				
270				40 × 40
330			40 × 40	40 × 45 45 × 40
390			40 × 40	40 × 50 45 × 40 50 × 40
470		40 × 40	40 × 45 45 × 40 50 × 40	40 × 55 45 × 45 50 × 45
560	40 × 40	40 × 45 45 × 40	40 × 55 45 × 45 50 × 45	40 × 65 45 × 55 50 × 50
680	40 × 45	40 × 50 45 × 45 50 × 40	40 × 60 45 × 50 50 × 50	40 × 75 45 × 60 50 × 55
820	40 × 50 45 × 40 50 × 40	40 × 60 45 × 50 50 × 45	40 × 70 45 × 60 50 × 55	40 × 85 45 × 70 50 × 65
1000	40 × 55 45 × 45 50 × 45	40 × 70 45 × 60 50 × 55	40 × 85 45 × 70 50 × 60	40 × 105 45 × 85 50 × 75
1200	40 × 65 45 × 55 50 × 50	40 × 80 45 × 65 50 × 60	40 × 95 45 × 80 50 × 70	45 × 95 50 × 85
1500	40 × 80 45 × 65 50 × 60	40 × 100 45 × 80 50 × 70	45 × 95 50 × 80	50 × 100
1800	40 × 90 45 × 75 50 × 65	45 × 95 50 × 80	50 × 95	
2200	45 × 85 50 × 75	50 × 95		
2700	45 × 105 50 × 90			
3300	50 × 105			

Technical data and ordering codes

C_R 100 Hz, 20 °C μF	Case dimensions $d \times l$ mm \times mm	ESR_{typ} 100 Hz 20 °C m Ω	ESR_{typ} 300 Hz 60 °C m Ω	Z_{max} 10 KHz 20 °C m Ω	$I_{\text{AC,max}}$ 100 Hz 60 °C A	$I_{\text{AC,max}}$ 100 Hz 85 °C A	$I_{\text{AC, R}}$ 100 Hz 105 °C A	Ordering code (composition see below)
$V_R = 400 \text{ V DC}$								
560	40 × 40	190	55	290	6.39	4.73	2.71	B43613A9567M0##
680	40 × 45	160	45	240	7.26	5.38	3.08	B43613A9687M0##
820	40 × 50	130	38	200	8.22	6.09	3.49	B43613A9827M0##
820	45 × 40	130	40	210	7.94	5.88	3.37	B43613B9827M0##
820	50 × 40	140	45	210	8.13	6.02	3.44	B43613C9827M0##
1000	40 × 55	110	32	170	9.35	6.93	3.97	B43613A9108M0##
1000	45 × 45	110	36	170	9.04	6.69	3.83	B43613B9108M0##
1000	50 × 45	110	38	180	9.24	6.84	3.91	B43613C9108M0##
1200	40 × 65	90	26	140	10.7	7.97	4.57	B43613A9128M0##
1200	45 × 55	90	28	140	10.5	7.78	4.45	B43613B9128M0##
1200	50 × 50	95	32	150	10.3	7.66	4.38	B43613C9128M0##
1500	40 × 80	70	22	110	12.7	9.48	5.43	B43613A9158M0##
1500	45 × 65	75	24	120	12.2	9.10	5.21	B43613B9158M0##
1500	50 × 60	75	26	120	12.1	9.01	5.16	B43613C9158M0##
1800	40 × 90	60	18	100	14.6	10.8	6.23	B43613A9188M0##
1800	45 × 75	60	20	100	14.0	10.3	5.95	B43613B9188M0##
1800	50 × 65	65	22	100	13.4	9.98	5.71	B43613C9188M0##
2200	45 × 85	50	17	80	16.1	11.9	6.85	B43613A9228M0##
2200	50 × 75	50	19	85	15.4	11.4	6.56	B43613B9228M0##
2700	45 × 105	40	14	65	19.0	14.1	8.09	B43613A9278M0##
2700	50 × 90	40	15	70	18.0	13.3	7.66	B43613B9278M0##
3300	50 × 105	36	13	55	20.8	15.4	8.86	B43613A9338M0##

Capacitors with 50 mm case diameter are only available with 5-pin snap-in terminals.

Composition of ordering code

- ## = Terminal style and insulation feature
- 50 = 4-/5-pin snap-in standard terminals and PET sleeve
- 57 = 4-/5-pin snap-in short terminals and PET sleeve
- 70 = 4-/5-pin snap-in standard terminals and PVC sleeve with additional PET insulation cap on terminal side
- 77 = 4-/5-pin snap-in short terminals and PVC sleeve with additional PET insulation cap on terminal side

C_R 100 Hz, 20 °C μF	Case dimensions $d \times l$ mm \times mm	ESR_{typ} 100 Hz 20 °C m Ω	ESR_{typ} 300 Hz 60 °C m Ω	Z_{max} 10 KHz 20 °C m Ω	$I_{\text{AC,max}}$ 100 Hz 60 °C A	$I_{\text{AC,max}}$ 100 Hz 85 °C A	$I_{\text{AC, R}}$ 100 Hz 105 °C A	Ordering code (composition see below)
$V_R = 450 \text{ V DC}$								
470	40 \times 40	200	55	300	6.02	4.46	2.55	B43613A5477M0##
560	40 \times 45	170	50	250	6.79	5.03	2.88	B43613A5567M0##
560	45 \times 40	170	50	260	6.86	5.08	2.91	B43613B5567M0##
680	40 \times 50	140	40	210	7.74	5.73	3.28	B43613A5687M0##
680	45 \times 45	140	40	210	7.79	5.77	3.30	B43613B5687M0##
680	50 \times 40	140	50	220	7.66	5.67	3.24	B43613C5687M0##
820	40 \times 60	110	34	170	8.95	6.63	3.79	B43613A5827M0##
820	45 \times 50	120	36	180	8.79	6.51	3.72	B43613B5827M0##
820	50 \times 45	120	40	190	8.68	6.42	3.67	B43613C5827M0##
1000	40 \times 70	95	28	140	10.3	7.69	4.40	B43613A5108M0##
1000	45 \times 60	100	30	150	10.2	7.56	4.33	B43613B5108M0##
1000	50 \times 55	100	32	150	10.1	7.55	4.32	B43613C5108M0##
1200	40 \times 80	80	24	120	11.9	8.82	5.05	B43613A5128M0##
1200	45 \times 65	80	26	130	11.4	8.48	4.85	B43613B5128M0##
1200	50 \times 60	80	28	130	11.3	8.41	4.81	B43613C5128M0##
1500	40 \times 100	65	19	100	14.2	10.5	6.06	B43613A5158M0##
1500	45 \times 80	65	20	100	13.6	10.0	5.77	B43613B5158M0##
1500	50 \times 70	65	22	110	13.2	9.79	5.60	B43613C5158M0##
1800	45 \times 95	55	17	85	15.6	11.6	6.66	B43613A5188M0##
1800	50 \times 80	55	20	85	15.0	11.1	6.37	B43613B5188M0##
2200	50 \times 95	45	16	70	17.4	12.9	7.40	B43613A5228M0##

Capacitors with 50 mm case diameter are only available with 5-pin snap-in terminals.

Composition of ordering code

- ## = Terminal style and insulation feature
- 50 = 4-/5-pin snap-in standard terminals and PET sleeve
- 57 = 4-/5-pin snap-in short terminals and PET sleeve
- 70 = 4-/5-pin snap-in standard terminals and PVC sleeve with additional PET insulation cap on terminal side
- 77 = 4-/5-pin snap-in short terminals and PVC sleeve with additional PET insulation cap on terminal side

C_R 100 Hz, 20 °C μF	Case dimensions $d \times l$ mm \times mm	ESR_{typ} 100 Hz 20 °C m Ω	ESR_{typ} 300 Hz 60 °C m Ω	Z_{max} 10 KHz 20 °C m Ω	$I_{\text{AC,max}}$ 100 Hz 60 °C A	$I_{\text{AC,max}}$ 100 Hz 85 °C A	$I_{\text{AC, R}}$ 100 Hz 105 °C A	Ordering code (composition see below)
$V_R = 500 \text{ V DC}$								
330	40 × 40	250	75	370	5.08	3.76	2.00	B43613A6337M0##
390	40 × 40	220	65	320	5.55	4.11	2.18	B43613A6397M0##
470	40 × 45	180	55	260	6.31	4.67	2.48	B43613A6477M0##
470	45 × 40	180	55	270	6.36	4.71	2.50	B43613B6477M0##
470	50 × 40	180	50	260	6.91	5.11	2.71	B43613C6477M0##
560	40 × 55	150	45	220	7.24	5.36	2.85	B43613A6567M0##
560	45 × 45	150	50	230	7.17	5.30	2.81	B43613B6567M0##
560	50 × 45	150	45	220	7.78	5.76	3.06	B43613C6567M0##
680	40 × 60	120	38	180	8.26	6.11	3.24	B43613A6687M0##
680	45 × 50	130	40	190	8.13	6.02	3.19	B43613B6687M0##
680	50 × 50	120	36	180	8.82	6.53	3.46	B43613C6687M0##
820	40 × 70	100	32	150	9.51	7.04	3.74	B43613A6827M0##
820	45 × 60	100	32	160	9.38	6.94	3.68	B43613B6827M0##
820	50 × 55	100	30	150	9.94	7.36	3.91	B43613C6827M0##
1000	40 × 85	85	26	130	11.1	8.23	4.37	B43613A6108M0##
1000	45 × 70	85	28	130	10.8	8.01	4.25	B43613B6108M0##
1000	50 × 60	85	26	130	11.2	8.35	4.43	B43613C6108M0##
1200	40 × 95	70	22	110	12.8	9.48	5.03	B43613A6128M0##
1200	45 × 80	70	24	110	12.3	9.14	4.85	B43613B6128M0##
1200	50 × 70	70	22	110	12.8	9.54	5.07	B43613C6128M0##
1500	45 × 95	60	19	85	14.6	10.8	5.74	B43613A6158M0##
1500	50 × 80	55	18	85	15.0	11.1	5.93	B43613B6158M0##
1800	50 × 95	45	15	70	17.3	12.8	6.81	B43613A6188M0##

Capacitors with 50 mm case diameter are only available with 5-pin snap-in terminals.

Composition of ordering code

- ## = Terminal style and insulation feature
- 50 = 4-/5-pin snap-in standard terminals and PET sleeve
- 57 = 4-/5-pin snap-in short terminals and PET sleeve
- 70 = 4-/5-pin snap-in standard terminals and PVC sleeve with additional PET insulation cap on terminal side
- 77 = 4-/5-pin snap-in short terminals and PVC sleeve with additional PET insulation cap on terminal side

C_R 100 Hz, 20 °C μF	Case dimensions $d \times l$ mm × mm	ESR_{typ} 100 Hz 20 °C m Ω	ESR_{typ} 300 Hz 60 °C m Ω	Z_{max} 10 KHz 20 °C m Ω	$I_{\text{AC,max}}$ 100 Hz 60 °C A	$I_{\text{AC,max}}$ 100 Hz 85 °C A	$I_{\text{AC, R}}$ 100 Hz 105 °C A	Ordering code (composition see below)
$V_R = 550 \text{ V DC}$								
270	40 × 40	440	110	690	4.55	3.38	1.71	B43613A7277M0##
330	40 × 45	360	90	560	5.21	3.86	1.95	B43613A7337M0##
330	45 × 40	360	95	570	5.30	3.93	1.99	B43613B7337M0##
390	40 × 50	310	80	480	5.84	4.33	2.19	B43613A7397M0##
390	45 × 40	310	80	490	5.78	4.28	2.17	B43613B7397M0##
390	50 × 40	310	80	480	6.24	4.62	2.34	B43613C7397M0##
470	40 × 55	260	65	400	6.63	4.92	2.49	B43613A7477M0##
470	45 × 45	260	70	400	6.55	4.86	2.46	B43613B7477M0##
470	50 × 45	260	65	400	7.06	5.24	2.65	B43613C7477M0##
560	40 × 65	220	55	340	7.58	5.62	2.85	B43613A7567M0##
560	45 × 55	220	55	340	7.54	5.60	2.83	B43613B7567M0##
560	50 × 50	210	55	330	7.94	5.89	2.98	B43613C7567M0##
680	40 × 75	180	45	280	8.76	6.50	3.29	B43613A7687M0##
680	45 × 60	180	50	280	8.56	6.35	3.21	B43613B7687M0##
680	50 × 55	180	45	280	9.01	6.68	3.38	B43613C7687M0##
820	40 × 85	150	40	230	10.1	7.51	3.80	B43613A7827M0##
820	45 × 70	150	40	230	9.84	7.30	3.69	B43613B7827M0##
820	50 × 65	150	40	230	10.3	7.66	3.88	B43613C7827M0##
1000	40 × 105	120	32	190	11.9	8.84	4.48	B43613A7108M0##
1000	45 × 85	120	32	190	11.4	8.52	4.31	B43613B7108M0##
1000	50 × 75	120	32	190	11.8	8.82	4.47	B43613C7108M0##
1200	45 × 95	100	28	160	13.1	9.77	4.95	B43613A7128M0##
1200	50 × 85	100	26	160	13.5	10.0	5.10	B43613B7128M0##
1500	50 × 100	80	22	130	16.0	11.9	6.03	B43613A7158M0##

Capacitors with 50 mm case diameter are only available with 5-pin snap-in terminals.

Composition of ordering code

- ## = Terminal style and insulation feature
- 50 = 4-/5-pin snap-in standard terminals and PET sleeve
- 57 = 4-/5-pin snap-in short terminals and PET sleeve
- 70 = 4-/5-pin snap-in standard terminals and PVC sleeve with additional PET insulation cap on terminal side
- 77 = 4-/5-pin snap-in short terminals and PVC sleeve with additional PET insulation cap on terminal side

Remark:

- For useful life calculations, please use our web-based "AlCap Useful Life Calculation Tool", which can be found on the Internet under the following link:
www.tdk-electronics.tdk.com/en/alcap
The "AlCap Useful Life Calculation Tool" provides calculations of useful life as well as additional data for selected capacitor types under operating conditions defined by the user.

Cautions and warnings

Personal safety

The electrolytes used have been optimized both with a view to the intended application and with regard to health and environmental compatibility. They do not contain any solvents that are detrimental to health, e.g. dimethyl formamide (DMF) or dimethyl acetamide (DMAC). Furthermore, some of the high-voltage electrolytes used are self-extinguishing.

As far as possible, we do not use any dangerous chemicals or compounds to produce operating electrolytes, although in exceptional cases, such materials must be used in order to achieve specific physical and electrical properties because no alternative materials are currently known.

We do, however, restrict the amount of dangerous materials used in our products to an absolute minimum.

Materials and chemicals used in our aluminum electrolytic capacitors are continuously adapted in compliance with the TDK Electronics Corporate Environmental Policy and the latest EU regulations and guidelines such as RoHS, REACH/SVHC, GADSL, and ELV.

MDS (Material Data Sheets) are available on our website for all types listed in the data book.

MDS for customer specific capacitors are available upon request.

Nevertheless, the following rules should be observed when handling aluminum electrolytic capacitors: No electrolyte should come into contact with eyes or skin. If electrolyte does come into contact with the skin, wash the affected areas immediately with running water. If the eyes are affected, rinse them for 10 minutes with plenty of water. If symptoms persist, seek medical treatment. Avoid inhaling electrolyte vapor or mists. Workplaces and other affected areas should be well ventilated. Clothing that has been contaminated by electrolyte must be changed and rinsed in water.

Product safety

The table below summarizes the safety instructions that must be observed without fail. A detailed description can be found in the relevant sections of separate file chapter "General technical information"

Topic	Safety information	Reference chapter "General technical information"
Polarity	Make sure that polar capacitors are connected with the right polarity.	1 "Basic construction of aluminum electrolytic capacitors"
Reverse voltage	Voltages of opposite polarity should be prevented by connecting a diode.	3.1.6 "Reverse voltage"
Mounting position of capacitors with screw or multi-pin terminals	Multi-pin capacitors with pressure relief vent on the can base must not be mounted with terminals facing up unless otherwise specified.	11.1 "Mounting positions of capacitors with screw or multi-pin terminals"
Robustness of terminals	The following maximum tightening torques must not be exceeded when connecting screw terminals: M5: 2.5 Nm M6: 4.0 Nm	11.2 "Mounting torques"
Mounting of single-ended capacitors	The internal structure of single-ended capacitors might be damaged if excessive force is applied to the lead wires. Avoid any compressive, tensile or flexural stress. Do not move the capacitor after soldering to PC board. Do not pick up the PC board by the soldered capacitor. Do not insert the capacitor on the PC board with a hole space different to the lead space specified.	11.3 "Mounting considerations for single-ended capacitors"
Soldering	Do not exceed the specified time or temperature limits during soldering.	11.5 "Soldering"
Soldering, cleaning agents	Do not allow halogenated hydrocarbons to come into contact with aluminum electrolytic capacitors.	11.6 "Cleaning agents"
Upper category temperature	Do not exceed the upper category temperature.	7.2 "Maximum permissible operating temperature"
Passive flammability	Avoid external energy, e.g. fire.	8.1 "Passive flammability"
Active flammability	Avoid overload of the capacitors.	8.2 "Active flammability"

Topic	Safety information	Reference chapter "General technical information"
Maintenance	Make periodic inspections of the capacitors. Before the inspection, make sure that the power supply is turned off and carefully discharge the capacitors. Do not apply excessive mechanical stress to the capacitor terminals when mounting.	10 "Maintenance"
Storage	Do not store capacitors at high temperatures or high humidity. Capacitors should be stored at +5 to +35 °C and a relative humidity of $\leq 75\%$.	7.3 "Shelf life and storage conditions"
		Reference chapter "Capacitors with screw terminals"
Breakdown strength of insulating sleeves	Do not damage the insulating sleeve, especially when ring clips are used for mounting.	"Screw terminals – accessories"

Display of ordering codes for TDK Electronics products

The ordering code for one and the same product can be represented differently in data sheets, data books, other publications, on the company website, or in order-related documents such as shipping notes, order confirmations and product labels. The varying representations of the ordering codes are due to different processes employed and do not affect the specifications of the respective products.

Detailed information can be found on the Internet under www.tdk-electronics.tdk.com/orderingcodes.

Symbols and terms

Symbol	English	German
C	Capacitance	Kapazität
C _R	Rated capacitance	Nennkapazität
C _S	Series capacitance	Serienkapazität
C _{S,T}	Series capacitance at temperature T	Serienkapazität bei Temperatur T
C _f	Capacitance at frequency f	Kapazität bei Frequenz f
d	Case diameter, nominal dimension	Gehäusedurchmesser, Nennmaß
d _{max}	Maximum case diameter	Maximaler Gehäusedurchmesser
ESL	Self-inductance	Eigeninduktivität
ESR	Equivalent series resistance	Ersatzserienwiderstand
ESR _f	Equivalent series resistance at frequency f	Ersatzserienwiderstand bei Frequenz f
ESR _T	Equivalent series resistance at temperature T	Ersatzserienwiderstand bei Temperatur T
f	Frequency	Frequenz
I	Current	Strom
I _{AC}	Alternating current (ripple current)	Wechselstrom
I _{AC,RMS}	Root-mean-square value of alternating current	Wechselstrom, Effektivwert
I _{AC,f}	Ripple current at frequency f	Wechselstrom bei Frequenz f
I _{AC,max}	Maximum permissible ripple current	Maximal zulässiger Wechselstrom
I _{AC,R}	Rated ripple current	Nennwechselstrom
I _{leak}	Leakage current	Reststrom
I _{leak,op}	Operating leakage current	Betriebsreststrom
l	Case length, nominal dimension	Gehäuselänge, Nennmaß
l _{max}	Maximum case length (without terminals and mounting stud)	Maximale Gehäuselänge (ohne Anschlüsse und Gewindebolzen)
R	Resistance	Widerstand
R _{ins}	Insulation resistance	Isolationswiderstand
R _{symm}	Balancing resistance	Symmetrierwiderstand
T	Temperature	Temperatur
ΔT	Temperature difference	Temperaturdifferenz
T _A	Ambient temperature	Umgebungstemperatur
T _B	Capacitor base temperature	Temperatur des Gehäusebodens
T _C	Case temperature	Gehäusetemperatur
t	Time	Zeit
Δt	Period	Zeitraum
t _b	Service life (operating hours)	Brauchbarkeitsdauer (Betriebszeit)
V	Voltage	Spannung
V _F	Forming voltage	Formierspannung
V _{op}	Operating voltage	Betriebsspannung
V _R	Rated voltage, DC voltage	Nennspannung, Gleichspannung
V _S	Surge voltage	Spitzenspannung
X _C	Capacitive reactance	Kapazitiver Blindwiderstand

Symbol	English	German
X_L	Inductive reactance	Induktiver Blindwiderstand
Z	Impedance	Scheinwiderstand
Z_T	Impedance at temperature T	Scheinwiderstand bei Temperatur T
$\tan \delta$	Dissipation factor	Verlustfaktor
λ	Failure rate	Ausfallrate
ϵ_0	Absolute permittivity	Elektrische Feldkonstante
ϵ_r	Relative permittivity	Dielektrizitätszahl
ω	Angular frequency; $2 \cdot \pi \cdot f$	Kreisfrequenz; $2 \cdot \pi \cdot f$

Note:

All dimensions are given in mm.

The following applies to all products named in this publication:

- 1 Some parts of this publication contain **statements about the suitability of our products for certain areas of application**. These statements are based on our knowledge of typical requirements that are often placed on our products in the areas of application concerned. We nevertheless expressly point out **that such statements cannot be regarded as binding statements about the suitability of our products for a particular customer application**. As a rule we are either unfamiliar with individual customer applications or less familiar with them than the customers themselves. For these reasons, it is always ultimately incumbent on the customer to check and decide whether a product with the properties described in the product specification is suitable for use in a particular customer application.
- 2 We also point out that **in individual cases, a malfunction of electronic components or failure before the end of their usual service life cannot be completely ruled out in the current state of the art, even if they are operated as specified**. In customer applications requiring a very high level of operational safety and especially in customer applications in which the malfunction or failure of an electronic component could endanger human life or health (e.g. in accident prevention or life-saving systems), it must therefore be ensured by means of suitable design of the customer application or other action taken by the customer (e.g. installation of protective circuitry or redundancy) that no injury or damage is sustained by third parties in the event of malfunction or failure of an electronic component.
- 3 **The warnings, cautions and product-specific notes must be observed.**
- 4 In order to satisfy certain technical requirements, **some of the products described in this publication may contain substances subject to restrictions in certain jurisdictions (e.g. because they are classed as hazardous)**. Useful information on this will be found in our Material Data Sheets on the Internet (www.tdk-electronics.tdk.com/material). Should you have any more detailed questions, please contact our sales offices.
- 5 We constantly strive to improve our products. Consequently, **the products described in this publication may change from time to time**. The same is true of the corresponding product specifications. Please check therefore to what extent product descriptions and specifications contained in this publication are still applicable before or when you place an order.
We also **reserve the right to discontinue production and delivery of products**. Consequently, we cannot guarantee that all products named in this publication will always be available. The aforementioned does not apply in the case of individual agreements deviating from the foregoing for customer-specific products.
- 6 Unless otherwise agreed in individual contracts, **all orders are subject to our General Terms and Conditions of Supply**.
- 7 **Our manufacturing sites serving the automotive business apply the IATF 16949 standard**. The IATF certifications confirm our compliance with requirements regarding the quality management system in the automotive industry. Referring to customer requirements and customer specific requirements ("CSR") TDK always has and will continue to have the policy of respecting individual agreements. Even if IATF 16949 may appear to support the acceptance of unilateral requirements, we hereby like to emphasize that **only requirements mutually agreed upon can and will be implemented in our Quality Management System**. For clarification purposes we like to point out that obligations from IATF 16949 shall only become legally binding if individually agreed upon.

Important notes

- 8 The trade names EPCOS, CarXield, CeraCharge, CeraDiode, CeraLink, CeraPad, CeraPlas, CSMP, CTVS, DeltaCap, DigiSiMic, FilterCap, FormFit, InsuGate, LeaXield, MediPlas, MiniBlue, MiniCell, MKD, MKK, ModCap, MotorCap, PCC, PhaseCap, PhaseCube, PhaseMod, PhiCap, PiezoBrush, PlasmaBrush, PowerHap, PQSine, PQvar, SIFERRIT, SIFI, SIKOREL, SilverCap, SIMDAD, SiMic, SIMID, SineFormer, SIOV, SurfIND, ThermoFuse, WindCap, XieldCap are **trademarks registered or pending** in Europe and in other countries. Further information will be found on the Internet at www.tdk-electronics.tdk.com/trademarks.

Release 2024-02