

# Aluminum electrolytic capacitors

Snap-in capacitors

**Series/Type:**            **B43659**  
**Date:**                     September 2024

## General-purpose grade capacitors

### Applications

- Power supplies
- Frequency converters
- Uninterruptible power supplies
- Solar inverters
- Not for automotive applications unless otherwise specified



### Features

- Extremely high CV product, ultra compact
- High reliability
- High ripple current capability
- RoHS-compatible

### Construction

- Aluminum case, insulated with PET sleeve without insulation sheet at the can bottom
- Snap-in solder pins to hold component in place on PC-board
- Minus pole marking on shrinking sleeve
- Minus pole not insulated from case
- Overload protection by pressure relief device on the base
- Length up to 100 mm on request

### Terminals

- Standard version with 2 terminals,  
2 lengths available: 6.3 and 4.5 mm
- 3 terminals to ensure correct insertion: length 4.5 mm

**Specifications and characteristics in brief**

Rated voltage $V_R$	450 V DC							
Surge voltage $V_S$	$1.10 \cdot V_R$ (15 ... 35 °C)							
Rated capacitance $C_R$	140 ... 1280 $\mu\text{F}$							
Capacitance tolerance	$\pm 20\% \triangleq M$							
Dissipation factor $\tan \delta$ (20 °C, 120 Hz)	$\leq 0.20$							
Leakage current $I_{\text{leak}}$ (5 min, 20 °C)	$I_{\text{leak}} \leq 0.3 \mu\text{A} \cdot \left( \frac{C_R}{\mu\text{F}} \cdot \frac{V_R}{\text{V}} \right)^{0.7} + 4 \mu\text{A}$							
Self-inductance ESL	Approx. 20 nH							
Useful life <sup>1)</sup> 105 °C; $V_R$ ; $I_{AC,R}$	> 2000 h	Requirements: $ \Delta C/C  \leq 20\%$ of initial value $\tan \delta \leq 2$ times initial specified limit $I_{\text{leak}} \leq$ initial specified limit						
Vibration resistance test	To IEC 60068-2-6:2007, test Fc: Frequency range 10 ... 55 Hz, displacement amplitude 0.35 mm, acceleration max. 5 g, duration 3 x 2 h. Capacitor mounted by its body which is rigidly clamped to the work surface.							
Characteristics at low temperature	Max. impedance ratio at 100 Hz <table border="1" data-bbox="498 805 733 901"> <tr> <td><math>\frac{V_R}{Z_{-25^\circ\text{C}} / Z_{20^\circ\text{C}}}</math></td> <td>450 V</td> </tr> <tr> <td><math>\frac{Z_{-25^\circ\text{C}}}{Z_{20^\circ\text{C}}}</math></td> <td>10</td> </tr> <tr> <td><math>\frac{Z_{-40^\circ\text{C}}}{Z_{20^\circ\text{C}}}</math></td> <td>20</td> </tr> </table>	$\frac{V_R}{Z_{-25^\circ\text{C}} / Z_{20^\circ\text{C}}}$	450 V	$\frac{Z_{-25^\circ\text{C}}}{Z_{20^\circ\text{C}}}$	10	$\frac{Z_{-40^\circ\text{C}}}{Z_{20^\circ\text{C}}}$	20	
$\frac{V_R}{Z_{-25^\circ\text{C}} / Z_{20^\circ\text{C}}}$	450 V							
$\frac{Z_{-25^\circ\text{C}}}{Z_{20^\circ\text{C}}}$	10							
$\frac{Z_{-40^\circ\text{C}}}{Z_{20^\circ\text{C}}}$	20							
IEC climatic category	To IEC 60068-1:2013: 25/105/56 (-25 °C/+105 °C/56 days damp heat test) The capacitors can be operated in the temperature range of -40 °C to +105 °C but the impedance at -40 °C must be taken into consideration.							
Sectional specification	IEC 60384-4:2016							

1) Refer to chapter "General technical information, 5 Useful life" on how to interpret useful life.

**Dimensional drawings**
**Snap-in capacitors with PET shrinking sleeve**

Insulation is marked with “PET” on the sleeve. Pressure relief device on the base.

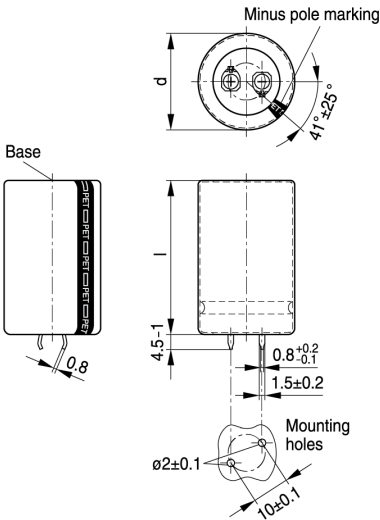

KAL1923-A-E

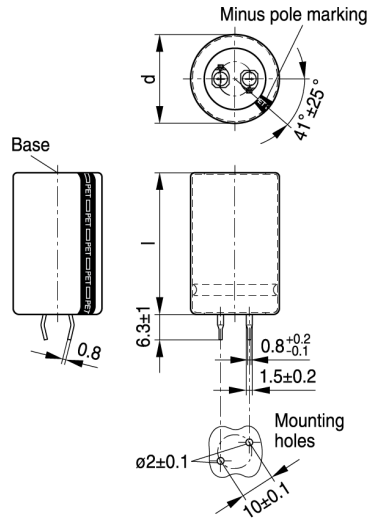
**Snap-in terminals (2 terminals, 4.5 mm)**

KAL1731-S-E

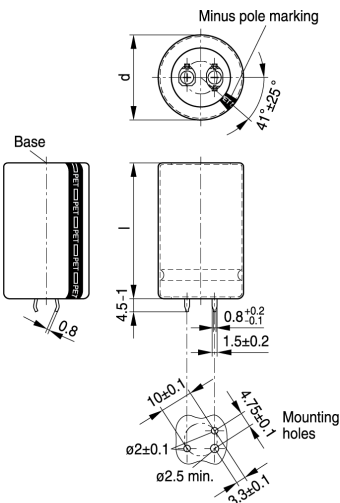
**Snap-in terminals (2 terminals, 6.3 mm)**

KAL1723-2-E

**Snap-in terminals (3 terminals, 4.5 mm)**

Dimensions (mm)		Approx. weight (g)	Packing units (pcs.)
d +1	l +2.5/-2		
22	25	9	160
22	30	12	160
22	35	15	160
22	40	18	160
22	45	20	160
22	50	24	160
Dimensions (mm)		Approx. weight (g)	Packing units (pcs.)
d +1	l +2.5/-2		
25.4	25	13	130
25.4	30	17	130
25.4	35	19	130
25.4	40	22	130
25.4	45	25	130
25.4	50	29	130
25.4	55	32	130
25.4	60	36	45

**Dimensional drawings**
**Snap-in capacitors with PET shrinking sleeve**

Insulation is marked with “PET” on the sleeve. Pressure relief device on the base.

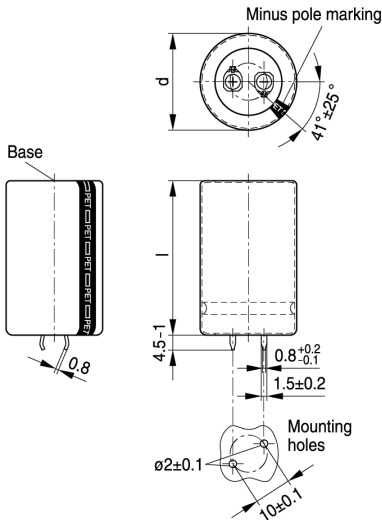

KAL1923-A-E

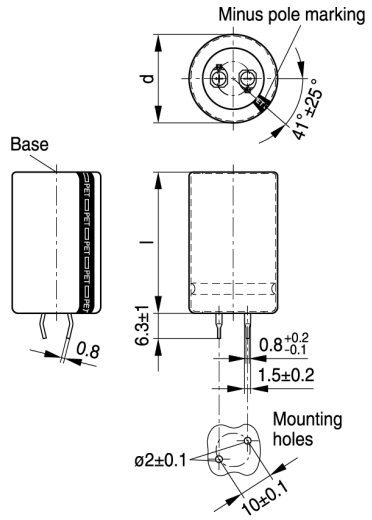
**Snap-in terminals (2 terminals, 4.5 mm)**

KAL1731-S-E

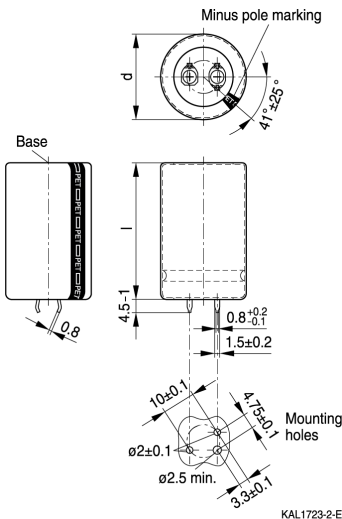
**Snap-in terminals (2 terminals, 6.3 mm)**

KAL1723-2-E

**Snap-in terminals (3 terminals, 4.5 mm)**

Dimensions (mm)	Approx. weight (g)	Packing units (pcs.)
d + 1   l + 2.5/-2		
30   25	17	80
30   30	23	80
30   35	29	80
30   40	36	80
30   45	41	80
30   50	46	80
30   55	53	80
30   60	58	60
Dimensions (mm)	Approx. weight (g)	Packing units (pcs.)
d + 1   l + 2.5/-2		
35   25	22	60
35   30	29	60
35   35	36	60
35   40	41	60
35   45	56	60
35   50	70	60
35   55	81	60
35   60	90	36

**Packaging of snap-in capacitors**

For ecological reasons the packing is pure cardboard.

**Ordering codes for terminal styles and insulation features**

Identification in 3<sup>rd</sup> block of ordering code

Snap-in capacitors

Terminal version	Insulation
	PET sleeve
Snap-in terminals (2 terminals, 4.5 mm)	M*57
Snap-in terminals (3 terminals, 4.5 mm)	M*52
Snap-in terminals (2 terminals, 6.3 mm)	M*50

\* Digit used for nominal capacitance indication.

Ordering example:

B43659A5108M057 } snap-in capacitor with 2 pin terminals (4.5 mm) and PET sleeve

B43659A5108M052 } snap-in capacitor with 3 pin terminals and PET sleeve

**Overview of available types**

The capacitance and voltage ratings listed below are available in different case sizes upon request. Other voltage and capacitance ratings are also available upon request.

$V_R$ (V DC)	450
	Case dimensions d x l (mm)
$C_R$ (μF)	
140	22 x 25
190	22 x 30
210	25.4 x 25
230	22 x 35
270	25.4 x 30
280	22 x 40
320	22 x 45 30 x 25
330	25.4 x 35
360	22 x 50
400	25.4 x 40
410	30 x 30 35 x 25
460	25.4 x 45
510	30 x 35
520	25.4 x 50
540	35 x 30
580	25.4 x 55
600	30 x 40
640	25.4 x 60
660	35 x 35
700	30 x 45
780	35 x 40
790	30 x 50
890	30 x 55
910	35 x 45
1000	30 x 60
1030	35 x 50
1150	35 x 55
1280	35 x 60

**Snap-in capacitors**
**B43659**
**Ultra compact – 105 °C**

## Technical data and ordering codes

C <sub>R</sub> 120 Hz 20 °C μF	Case dimensions d x l mm	ESR <sub>typ</sub> 120 Hz 20 °C mΩ	ESR <sub>typ</sub> 360 Hz 60 °C mΩ	I <sub>AC,max</sub> 120 Hz 60 °C A	I <sub>AC,max</sub> 120 Hz 85 °C A	I <sub>AC,R</sub> 120 Hz 105 °C A	Ordering code (composition see below)
<b>V<sub>R</sub> = 450 V DC</b>							
140	22 x 25	880	220	1.92	1.45	0.83	B43659A5147M05#
190	22 x 30	650	160	2.46	1.85	1.06	B43659A5197M05#
210	25.4 x 25	600	160	2.47	1.86	1.06	B43659A5217M05#
230	22 x 35	530	130	2.88	2.17	1.24	B43659A5237M05#
270	25.4 x 30	470	130	3.02	2.27	1.30	B43659A5277M05#
280	22 x 40	440	110	3.40	2.56	1.46	B43659A5287M05#
320	22 x 45	380	100	3.82	2.87	1.64	B43659A5327M05#
320	30 x 25	420	130	3.04	2.29	1.31	B43659B5327M05#
330	25.4 x 35	380	100	3.55	2.67	1.53	B43659A5337M05#
360	22 x 50	340	85	4.22	3.18	1.82	B43659A5367M05#
400	25.4 x 40	320	85	4.17	3.13	1.79	B43659A5407M05#
410	30 x 30	330	100	3.68	2.77	1.58	B43659A5417M05#
410	35 x 25	340	130	3.33	2.51	1.43	B43659B5417M05#
460	25.4 x 45	270	75	4.70	3.53	2.02	B43659A5467M05#
510	30 x 35	260	85	4.38	3.29	1.88	B43659A5517M05#
520	25.4 x 50	240	65	5.22	3.93	2.24	B43659A5527M05#
540	35 x 30	260	100	4.09	3.08	1.64	B43659A5547M05#
580	25.4 x 55	220	60	5.74	4.32	2.47	B43659A5587M05#
600	30 x 40	220	70	5.02	3.78	2.02	B43659A5607M05#
640	25.4 x 60	200	55	6.27	4.71	2.52	B43659A5647M05#
660	35 x 35	210	80	4.80	3.61	1.93	B43659A5667M05#
700	30 x 45	190	60	5.71	4.29	2.29	B43659A5707M05#
780	35 x 40	180	70	5.50	4.14	2.21	B43659A5787M05#
790	30 x 50	170	55	6.33	4.76	2.54	B43659A5797M05#
890	30 x 55	150	50	7.01	5.27	2.81	B43659A5897M05#
910	35 x 45	150	60	6.24	4.69	2.51	B43659A5917M05#
1000	30 x 60	130	45	7.74	5.82	3.11	B43659A5108M05#
1030	35 x 50	140	50	6.93	5.21	2.78	B43659A5108M35#
1150	35 x 55	120	50	7.50	5.64	3.01	B43659A5118M55#
1280	35 x 60	110	45	8.21	6.17	3.30	B43659A5128M85#

**Composition of ordering code**

# = Terminal style

7 = Snap-in terminals (2 terminals, 4.5 mm)

2 = Snap-in terminals (3 terminals, 4.5 mm)

0 = Snap-in terminals (2 terminals, 6.3 mm)



**Useful life<sup>1)</sup>**

For useful life calculations, please use our web-based "AlCap Useful Life Calculation Tool", which can be found on the Internet under the following link:

[www.tdk-electronics.tdk.com/alcap](http://www.tdk-electronics.tdk.com/alcap)

The AlCap Useful Life Calculation Tool provides calculations of useful life as well as additional data for selected capacitor types under operating conditions defined by the user.

In addition, it is possible to calculate useful life expectancies based on temperatures measured by the user in the application.

1) Refer to chapter "General technical information, 5 Useful life" on how to interpret useful life."

## Cautions and warnings

### Personal safety

The electrolytes used have been optimized both with a view to the intended application and with regard to health and environmental compatibility. They do not contain any solvents that are detrimental to health, e.g. dimethyl formamide (DMF) or dimethyl acetamide (DMAC). Furthermore, some of the high-voltage electrolytes used are self-extinguishing.

As far as possible, we do not use any dangerous chemicals or compounds to produce operating electrolytes, although in exceptional cases, such materials must be used in order to achieve specific physical and electrical properties because no alternative materials are currently known.

We do, however, restrict the amount of dangerous materials used in our products to an absolute minimum.

Materials and chemicals used in our aluminum electrolytic capacitors are continuously adapted in compliance with the TDK Electronics Corporate Environmental Policy and the latest EU regulations and guidelines such as RoHS, REACH/SVHC, GADSL, and ELV.

MDS (Material Data Sheets) are available on our website for all types listed in the data book. MDS for customer specific capacitors are available upon request.

Nevertheless, the following rules should be observed when handling aluminum electrolytic capacitors: No electrolyte should come into contact with eyes or skin. If electrolyte does come into contact with the skin, wash the affected areas immediately with running water. If the eyes are affected, rinse them for 10 minutes with plenty of water. If symptoms persist, seek medical treatment. Avoid inhaling electrolyte vapor or mists. Workplaces and other affected areas should be well ventilated. Clothing that has been contaminated by electrolyte must be changed and rinsed in water.

**Product safety**

The table below summarizes the safety instructions that must be observed without fail. A detailed description can be found in the relevant sections of separate file chapter "General technical information".

Topic	Safety information	Reference chapter "General technical information"
Polarity	Make sure that polar capacitors are connected with the right polarity.	1 "Basic construction of aluminum electrolytic capacitors"
Reverse voltage	Voltages of opposite polarity should be prevented by connecting a diode.	3.1.6 "Reverse voltage"
Mounting position of capacitors with screw or multi-pin terminals	Multi-pin capacitors with pressure relief vent on the can base must not be mounted with terminals facing up unless otherwise specified.	11.1 "Mounting positions of capacitors with screw or multi-pin terminals"
Robustness of terminals	The following maximum tightening torques must not be exceeded when connecting screw terminals: M5: 2.5 Nm M6: 4.0 Nm	11.2 "Mounting torques"
Mounting of single-ended capacitors	The internal structure of single-ended capacitors might be damaged if excessive force is applied to the lead wires. Avoid any compressive, tensile or flexural stress. Do not move the capacitor after soldering to PC board. Do not pick up the PC board by the soldered capacitor. Do not insert the capacitor on the PC board with a hole space different to the lead space specified.	11.3 "Mounting considerations for single-ended capacitors"
Soldering	Do not exceed the specified time or temperature limits during soldering.	11.5 "Soldering"
Soldering, cleaning agents	Do not allow halogenated hydrocarbons to come into contact with aluminum electrolytic capacitors.	11.6 "Cleaning agents"
Upper category temperature	Do not exceed the upper category temperature.	7.2 "Maximum permissible operating temperature"
Passive flammability	Avoid external energy, e.g. fire.	8.1 "Passive flammability"

Topic	Safety information	Reference chapter "General technical information"
Active flammability	Avoid overload of the capacitors.	8.2 "Active flammability"
Maintenance	Make periodic inspections of the capacitors. Before the inspection, make sure that the power supply is turned off and carefully discharge the capacitors. Do not apply excessive mechanical stress to the capacitor terminals when mounting.	10 "Maintenance"
Storage	Do not store capacitors at high temperatures or high humidity. Capacitors should be stored at +5 to +35 °C and a relative humidity of $\leq 75\%$ .	7.3 "Shelf life and storage conditions"
		Reference chapter "Capacitors with screw terminals"
Breakdown strength of insulating sleeves	Do not damage the insulating sleeve, especially when ring clips are used for mounting.	"Screw terminals – accessories"

### Display of ordering codes for TDK Electronics products

The ordering code for one and the same product can be represented differently in data sheets, data books, other publications, on the company website, or in order-related documents such as shipping notes, order confirmations and product labels. The varying representations of the ordering codes are due to different processes employed and do not affect the specifications of the respective products.

Detailed information can be found on the Internet under [www.tdk-electronics.tdk.com/orderingcodes](http://www.tdk-electronics.tdk.com/orderingcodes).

**Symbols and terms**

Symbol	English	German
C	Capacitance	Kapazität
$C_R$	Rated capacitance	Nennkapazität
$C_S$	Series capacitance	Serienkapazität
$C_{S,T}$	Series capacitance at temperature T	Serienkapazität bei Temperatur T
$C_f$	Capacitance at frequency f	Kapazität bei Frequenz f
d	Case diameter, nominal dimension	Gehäusedurchmesser, Nennmaß
$d_{max}$	Maximum case diameter	Maximaler Gehäusedurchmesser
ESL	Self-inductance	Eigeninduktivität
ESR	Equivalent series resistance	Ersatzserienwiderstand
$ESR_f$	Equivalent series resistance at frequency f	Ersatzserienwiderstand bei Frequenz f
$ESR_T$	Equivalent series resistance at temperature T	Ersatzserienwiderstand bei Temperatur T
f	Frequency	Frequenz
I	Current	Strom
$I_{AC}$	Alternating current (ripple current)	Wechselstrom
$I_{AC,RMS}$	Root-mean-square value of alternating current	Wechselstrom, Effektivwert
$I_{AC,f}$	Ripple current at frequency f	Wechselstrom bei Frequenz f
$I_{AC,max}$	Maximum permissible ripple current	Maximal zulässiger Wechselstrom
$I_{AC,R}$	Rated ripple current	Nennwechselstrom
$I_{leak}$	Leakage current	Reststrom
$I_{leak,op}$	Operating leakage current	Betriebsreststrom
l	Case length, nominal dimension	Gehäuselänge, Nennmaß
$l_{max}$	Maximum case length (without terminals and mounting stud)	Maximale Gehäuselänge (ohne Anschlüsse und Gewindebolzen)
R	Resistance	Widerstand
$R_{ins}$	Insulation resistance	Isolationswiderstand
$R_{symm}$	Balancing resistance	Symmetrierwiderstand
T	Temperature	Temperatur
$\Delta T$	Temperature difference	Temperaturdifferenz
$T_A$	Ambient temperature	Umgebungstemperatur
$T_B$	Capacitor base temperature	Temperatur des Gehäusebodens
$T_C$	Case temperature	Gehäusetemperatur
t	Time	Zeit
$\Delta t$	Period	Zeitraum
$t_b$	Service life (operating hours)	Brauchbarkeitsdauer (Betriebszeit)
V	Voltage	Spannung
$V_F$	Forming voltage	Formierspannung
$V_{op}$	Operating voltage	Betriebsspannung
$V_R$	Rated voltage, DC voltage	Nennspannung, Gleichspannung
$V_S$	Surge voltage	Spitzenspannung
$X_C$	Capacitive reactance	Kapazitiver Blindwiderstand

Symbol	English	German
$X_L$	Inductive reactance	Induktiver Blindwiderstand
$Z$	Impedance	Scheinwiderstand
$Z_T$	Impedance at temperature T	Scheinwiderstand bei Temperatur T
$\tan \delta$	Dissipation factor	Verlustfaktor
$\lambda$	Failure rate	Ausfallrate
$\epsilon_0$	Absolute permittivity	Elektrische Feldkonstante
$\epsilon_r$	Relative permittivity	Dielektrizitätszahl
$\omega$	Angular frequency; $2 \cdot \pi \cdot f$	Kreisfrequenz; $2 \cdot \pi \cdot f$

**Note:**

All dimensions are given in mm.

## Important notes

The following applies to all products named in this publication:

1. Some parts of this publication contain **statements about the suitability of our products for certain areas of application**. These statements are based on our knowledge of typical requirements that are often placed on our products in the areas of application concerned. We nevertheless expressly point out **that such statements cannot be regarded as binding statements about the suitability of our products for a particular customer application**. As a rule we are either unfamiliar with individual customer applications or less familiar with them than the customers themselves. For these reasons, it is always ultimately incumbent on the customer to check and decide whether a product with the properties described in the product specification is suitable for use in a particular customer application.
2. We also point out that **in individual cases, a malfunction of electronic components or failure before the end of their usual service life cannot be completely ruled out in the current state of the art, even if they are operated as specified**. In customer applications requiring a very high level of operational safety and especially in customer applications in which the malfunction or failure of an electronic component could endanger human life or health (e.g. in accident prevention or life-saving systems), it must therefore be ensured by means of suitable design of the customer application or other action taken by the customer (e.g. installation of protective circuitry or redundancy) that no injury or damage is sustained by third parties in the event of malfunction or failure of an electronic component.
3. **The warnings, cautions and product-specific notes must be observed.**
4. In order to satisfy certain technical requirements, **some of the products described in this publication may contain substances subject to restrictions in certain jurisdictions (e.g. because they are classed as hazardous)**. Useful information on this will be found in our Material Data Sheets on the Internet ([www.tdk-electronics.tdk.com/material](http://www.tdk-electronics.tdk.com/material)). Should you have any more detailed questions, please contact our sales offices.
5. We constantly strive to improve our products. Consequently, **the products described in this publication may change from time to time**. The same is true of the corresponding product specifications. Please check therefore to what extent product descriptions and specifications contained in this publication are still applicable before or when you place an order.  
We also **reserve the right to discontinue production and delivery of products**. Consequently, we cannot guarantee that all products named in this publication will always be available. The aforementioned does not apply in the case of individual agreements deviating from the foregoing for customer-specific products.
6. Unless otherwise agreed in individual contracts, **all orders are subject to our General Terms and Conditions of Supply**.

## Important notes

7. **Our manufacturing sites serving the automotive business apply the IATF 16949 standard.**  
The IATF certifications confirm our compliance with requirements regarding the quality management system in the automotive industry. Referring to customer requirements and customer specific requirements (“CSR”) TDK always has and will continue to have the policy of respecting individual agreements. Even if IATF 16949 may appear to support the acceptance of unilateral requirements, we hereby like to emphasize that **only requirements mutually agreed upon can and will be implemented in our Quality Management System**. For clarification purposes we like to point out that obligations from IATF 16949 shall only become legally binding if individually agreed upon.
8. The trade names EPCOS, CarXield, CeraCharge, CeraDiode, CeraLink, CeraPad, CeraPlas, CSMP, CTVS, DeltaCap, DigiSiMic, FilterCap, FormFit, InsuGate, LeaXield, MediPlas, MiniBlue, MiniCell, MKD, MKK, ModCap, MotorCap, PCC, PhaseCap, PhaseCube, PhaseMod, PhiCap, PiezoBrush, PlasmaBrush, PowerHap, PQSine, PQvar, SIFERRIT, SIFI, SIKOREL, SilverCap, SIMDAD, SiMic, SIMID, SineFormer, SIOV, SurfIND, ThermoFuse, WindCap, XieldCap are **trademarks registered or pending** in Europe and in other countries. Further information will be found on the Internet at [www.tdk-electronics.tdk.com/trademarks](http://www.tdk-electronics.tdk.com/trademarks).

Release 2024-02