

Silicon PNP Power Transistors

2SB676

DESCRIPTION

- With TO-220C package
- High DC Current Gain
: $h_{FE}=2000$ @ $V_{CE}=-2V$, $I_C=-1A$ (Min.)
- DARLINGTON

APPLICATIONS

- For switching applications
- Hammer drive, pulse motor drive applications
- Power amplifier applications

PINNING

PIN	DESCRIPTION
1	Base
2	Collector; connected to mounting base
3	Emitter

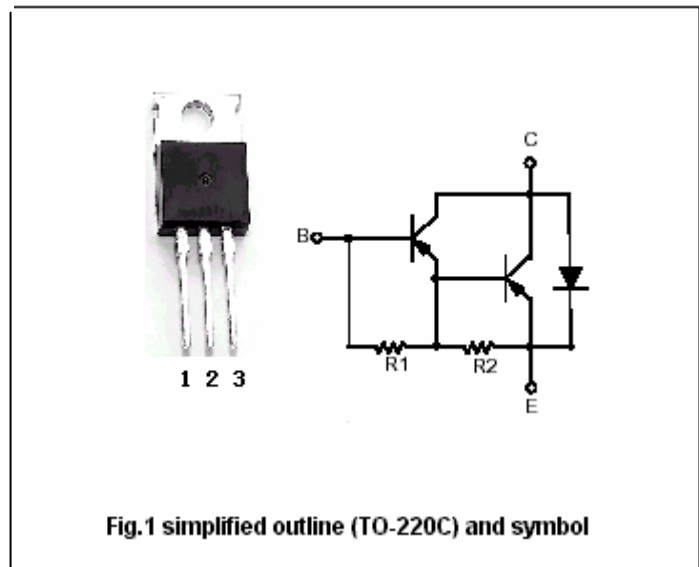
Absolute maximum ratings($T_a=25^\circ$)

SYMBOL	PARAMETER	CONDITIONS	VALUE	UNIT
V_{CBO}	Collector-base voltage	Open emitter	-100	V
V_{CEO}	Collector-emitter voltage	Open base	-80	V
V_{EBO}	Emitter-base voltage	Open collector	-5	V
I_C	Collector current-DC		-4	A
P_C	Collector power dissipation	$T_C=25^\circ$	30	W
T_j	Junction temperature		150	$^\circ$
T_{stg}	Storage temperature		-55~150	$^\circ$

Silicon PNP Power Transistors

2SB676

CHARACTERISTICS

T_j=25 °C unless otherwise specified

SYMBOL	PARAMETER	CONDITIONS	MIN	TYP.	MAX	UNIT
V _{(BR)CEO}	Collector-emitter breakdown voltage	I _C =-10mA, I _B =0	-80			V
V _{CEsat}	Collector-emitter saturation voltage	I _C =-3A, I _B =-6mA			-1.5	V
V _{BEsat}	Base-emitter saturation voltage	I _C =-3A, I _B =-6mA			-2.0	V
I _{CBO}	Collector cut-off current	V _{CB} =-100V, I _E =0			-20	μA
I _{EBO}	Emitter cut-off current	V _{EB} =-5V, I _C =0			-2.5	mA
h _{FE-1}	DC current gain	I _C =-1A ; V _{CE} =-2V	2000			
h _{FE-2}	DC current gain	I _C =-3A ; V _{CE} =-2V	1000			

Switching times

t _{on}	Turn-on time	V _{CE} =-30V, I _{B1} =-I _{B2} =-6mA R _L =10Ω		0.15		μs
t _s	Storage time			0.80		μs
t _f	Fall time			0.40		μs

Silicon PNP Power Transistors

2SB676

PACKAGE OUTLINE

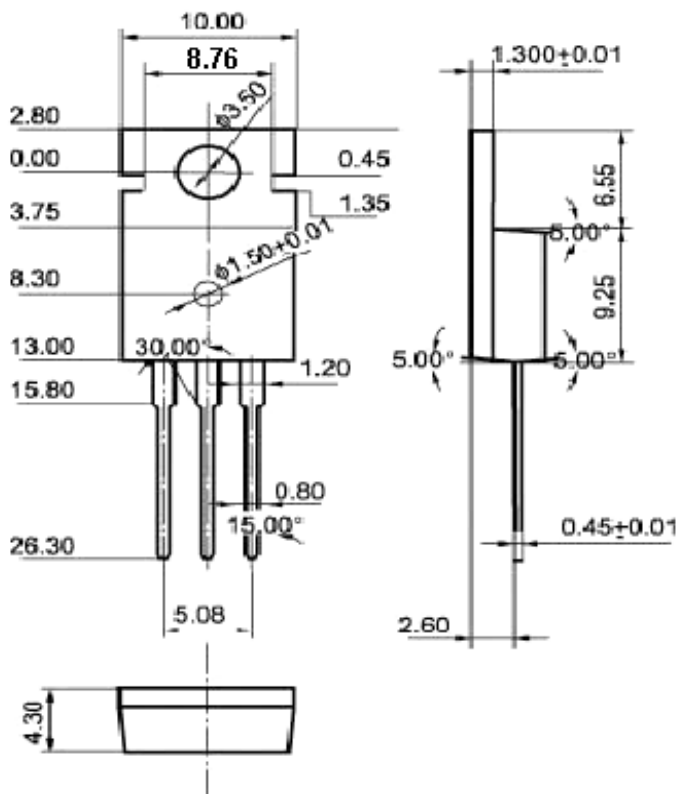

Fig.2 Outline dimensions