



Rated impedance 60 to 1000 Ω
Rated current 0,05 to 1 A



Construction

- Size 0603 (EIA) or 1608 (IEC)
- Multilayer technology with ferrite

Features

- Small size
- Suitable for reflow (IR and vapor phase) and wave soldering

Applications

Prevention of high-frequency EMI in

- computers, printers
- VCRs, TVs
- cordless phones
- mobile phones

Terminals

- Tinned
- Ni intermediate layer

Marking

No marking on component

Minimum marking on reel:

Manufacturer, part number, ordering code,
Z value and tolerance of Z value,
quantity, date of packing

Delivery mode

8-mm blister tape wound on 180-mm \varnothing reel

For details on taping, packing and packing units [see page 224](#)

General technical data

Impedance $ Z $	Measured with HP 4291A at frequency f_z
Rated current I_R	Maximum dc current at ambient temperature $T_A = 85^\circ\text{C}$
DC resistance R_{max}	Measured at 20°C ambient temperature
Climatic category	In accordance with IEC 60068-1 25/085/21 ($-25^\circ\text{C}/+85^\circ\text{C}/21$ days damp heat test)
Storage temperature	$-25^\circ\text{C}/+85^\circ\text{C}$
Soldering:	
Wave soldering	Maximum 250°C , 5 s
Infrared soldering	Maximum 240°C , 20 s temperature/time profile $> 200^\circ\text{C}$, max. 50 s
Vapor-phase soldering	Maximum $(215 \pm 5)^\circ\text{C}$, max. 50 s
Solderability	$(230 \pm 5)^\circ\text{C}$, $(4 \pm 0,5)$ s wetting of soldering area: $\geq 75\%$
Resistance to soldering heat	$(260 \pm 5)^\circ\text{C}$, $(10 \pm 0,5)$ s after preheating at 150°C , 60 s impedance change max. $\pm 30\%$
Permissible PCB bending	2 mm (100 mm long standard PCB)
Temperature cycles	$-25^\circ\text{C}/+125^\circ\text{C}$, for each 30 min., total 5 cycles impedance change $\leq 30\%$
Humidity test	40°C , 90 to 95 % r. h., 500 h impedance change $\leq 30\%$
Life test	500 at 85°C and rated current impedance change $\leq 30\%$

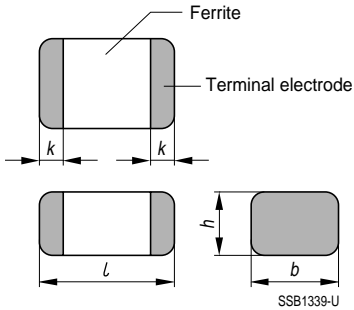
Dimensional drawing

Type	Size		Dimensions (mm)			
	EIA	IEC	<i>l</i>	<i>b</i>	<i>h</i>	<i>k</i>
B82482-A3	0603	1608	$1,6 \pm 0,15$	$0,8 \pm 0,15$	$0,8 \pm 0,15$	$0,3 \pm 0,2$

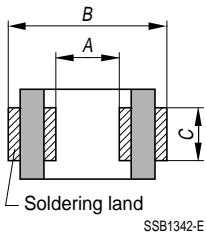
PCB layout recommendation

	Dimensions (mm)		
	<i>A</i>	<i>B</i>	<i>C</i>
Reflow soldering	0,8 ... 1,0	2,0 ... 2,6	0,8 ... 1,0
Wave soldering	0,8 ... 1,0	2,4 ... 3,0	0,6 ... 0,8

Characteristics and ordering codes

 For further technical data [see page 220](#)

Size EIA	IEC	$ Z $ Ω	Tolerance	f_z MHz	I_R A	R_{max} Ω	Ordering code
0603	1608	60	$\pm 25\%$	100	1,0	0,07	B82482-A3600-A
		120		100	0,5	0,1	B82482-A3121-A
		220		100	0,2	0,3	B82482-A3221-A
		600		100	0,1	0,8	B82482-A3601-A
		1000		100	0,05	1,0	B82482-A3102-A



Typical electrical characteristics

Impedance $|Z|$, real part R and imaginary part X versus frequency f

————— $|Z|$ - - - - - R - - - - - X

Size 0603

B82482-A3600-A

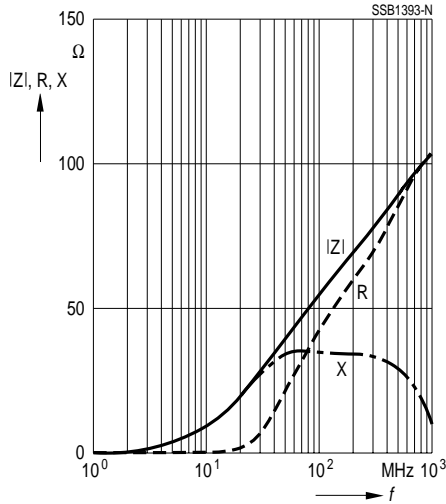

B82482-A3121-A

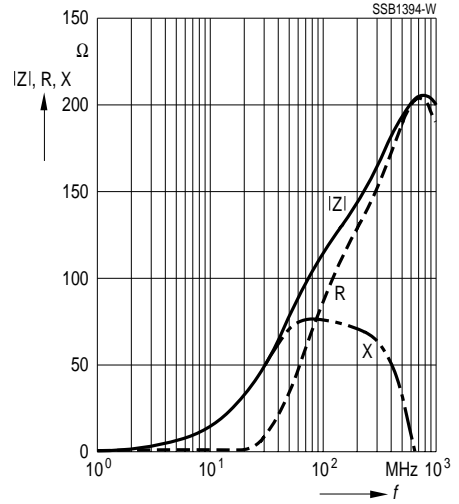

B82482-A3221-A

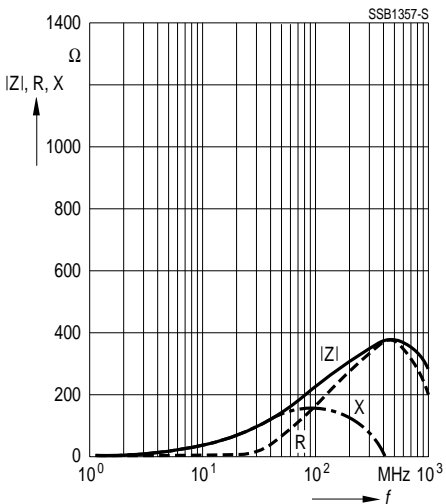

B82482-A3601-A

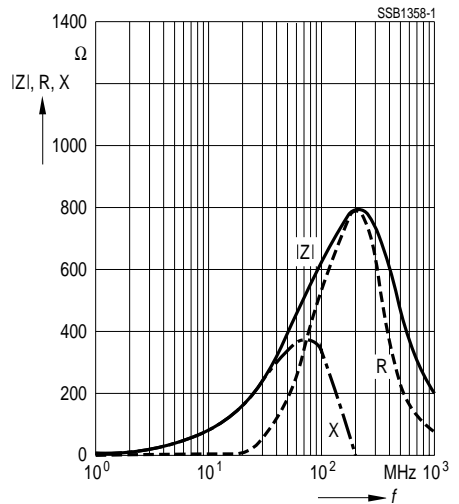



Typical electrical characteristics

Impedance $|Z|$, real part R and imaginary part X versus frequency f

————— $|Z|$ - - - - - R - - - - - X

Size 0603

B82482-A3102-A

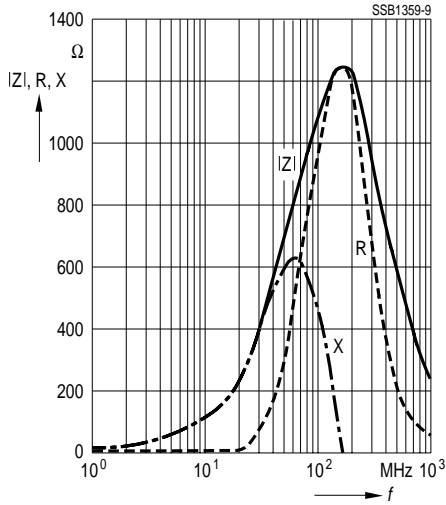

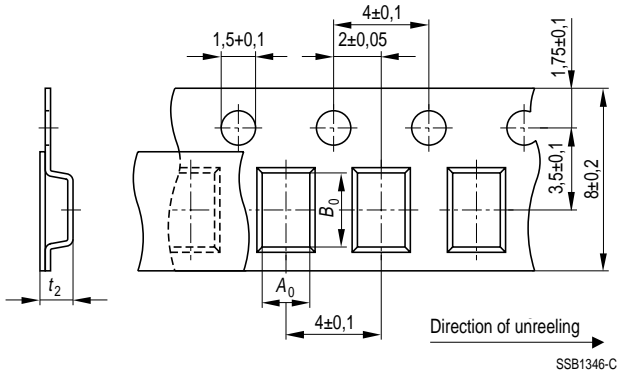
8-mm blister tape

Type	Size		Dimensions (mm)		
	EIA	IEC	A ₀ (max.)	B ₀ (max.)	t ₂ (max.)
B82482-A3	0603	1608	1,0 ± 0,15	1,8 ± 0,15	1,6

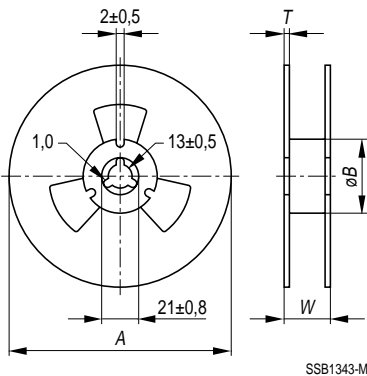
Reel packing

Type	Size		Dimensions (mm)				Packing unit Pieces/reel
	EIA	IEC	A	∅B	W	T	
B82482-A3	0603	1608	180 ± 3	36 ± 0,5	11 ± 1	1,2 ± 0,1	4000