

BA01303

Triple Band(EGSM900/DCS1800/PCS1900) InGaP HBT Front-end module

Specification are subject to change without notice.

DESCRIPTION

BA01303 is a front-end module for triple band (EGSM900/DCS1800/PCS1900) handheld phone using InGaP HBT technology.

FEATURES

- Low voltage operation
Vc=3.5V
- High output power
Po=33.0dBm(min.) @f=880 - 915MHz
Po=30.0dBm(min.) @f=1710 - 1785MHz
Po=30.0dBm(min.) @f=1850 - 1910MHz
- Single voltage operation
- Single power control terminal
- Band select switch
- Tx/Rx select switch
- Surface mount package
- 3 Stage amplifier
- 50ohms matched
- ESD capability >±8kV (@ANT pin)
- GPRS class12 compatible

OUTLINE DRAWING

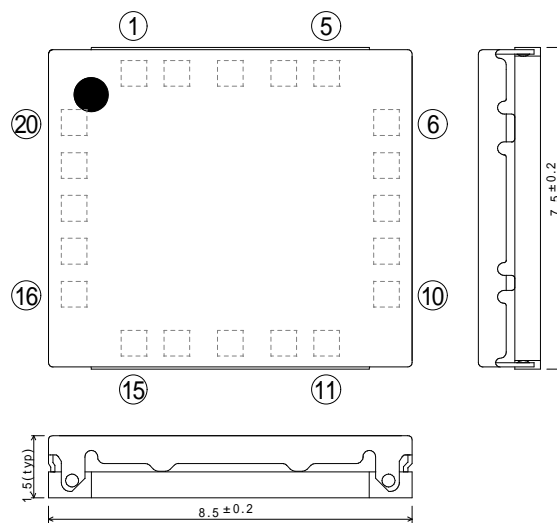

- | | | |
|----------------------------|--------------------------|------------------|
| 1. Vc(Vc12) | 8. Vcont3 | 15. Vc(Vc12) |
| 2. Vc(Vc3) | 9. ANT | 16. Pin(EGSM) |
| 3. GND | 10. Vcont2 | 17. Vband |
| 4. Power Monitor (DCS/PCS) | 11. Vcont1 (EGSM) | 18. GND |
| 5. Rx(EGSM) | 12. Power Monitor (EGSM) | 19. Vpc |
| 6. Rx(DCS) | 13. GND | 20. Pin(DCS/PCS) |
| 7. Rx(PCS) | 14. Vc(Vc3) | |

Unit : mm
Terminal metal : AgPt

APPLICATION

Triple band(EGSM/DCS/PCS) handheld phone.

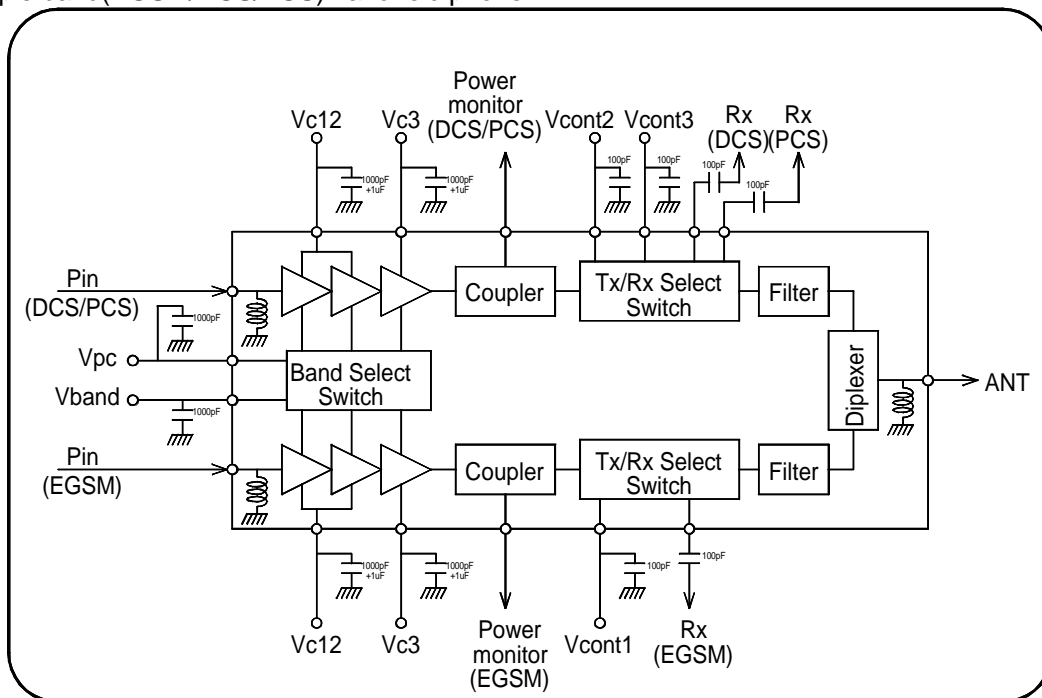

Mitsubishi Electric Corporation puts the maximum effort into making semiconductor products better and more reliable, but there is always the possibility that trouble may occur with them. Trouble with semiconductors may lead to personal injury, fire or property damage. Remember to give due consideration to safety when making your circuit designs, with appropriate measures such as (i) placement of substitutive, auxiliary circuits, (ii) use of non-flammable material or (iii) prevention against any malfunction or mishap.

ABSOLUTE MAXIMUM RATINGS (Ta=25deg.C)

Symbol	Parameter	Ratings	Unit
Vc	Supply voltage	7	V
Vpc	Power control voltage	3	V
Vband	External voltage for band select	3	V
Pin	Input power	10	dBm
Tc(op)	Operating case temperature	-30 - +85	deg.C
Tstg	Storage temperature	-40 - +100	deg.C

Note: Each maximum rating is guaranteed independently under pulse operation (duty cycle 4:8).

ELECTRICAL CHARACTERISTICS (Ta=25deg.C)

(Tx mode) Vc=3.5V, Po=33/30dBm, Pin=3dBm, Vcont(1/2)=2.6V, Vpc<2.6V, Duty cycle 2:8

Parameter	Symbol	Condition		Limits			Unit
				MIN	TYP	MAX	
Frequency range(Tx)	f		EGSM	880	-	915	MHz
			DCS/PCS	1710	-	1910	
Supply voltage	Vc			3.1	3.5	4.5	V
Output power	Po	Vc=3.5V, Vpc=2.6V Pin=3dBm, Vcont=2.6V	EGSM	33.0	33.5	-	dBm
			DCS/PCS	30.0	30.5	-	
Efficiency	Eff		EGSM	38	43	-	%
			DCS/PCS	30	35	-	
Control voltage range	Vpc			0.2	-	2.6	V
Power control current	Ipc			-	4.0	5.5	mA
Band select current	Iband	Vband=2.6V		-	0.7	1.2	mA
Harmonics	2 - 14fo		EGSM	-	-	-33	dBm
	2 - 7fo		DCS	-	-	-33	
	2 - 6fo		PCS	-	-	-33	
Leakage current	Ileak	Vc=4.5V, Vpc=0V No input power		-	10	40	uA
Coupling value	Pm		EGSM	18.5	20.0	21.5	dBc
			DCS/PCS	12.5	14.0	15.5	
Isolation for Rx	Prx		Rx(EGSM) port	-	-	15	dBm
			Rx(DCS/PCS) port	-	-	13	
Isolation 1	Iso1	Vpc=0V, Vcont=2.6V		-	-	-38	dBm
Isolation 2	Iso2	Vpc=0V, Vcont=0V		-	-	-50	dBm
Rx noise power	Np		EGSM(@935MHz)	-	-	-82	dBm/
			DCS/PCS	-	-	-75	100kHz
Switching time	ts			-	-	2	usec
Stability	OSC	Vc=3.5V, Vpc=0.2 - 2.6V Load VSWR=10:1 (all phase)		No oscillation more than -36dBm			
Frequency range(Rx)	f		EGSM	925	-	960	MHz
			DCS	1805	-	1880	
			PCS	1930	-	1990	
Insertion loss (Rx)	IL	Vcont1,2,3=0V	EGSM	-	1.1	1.3	dB
		Vcont1,2,3=0V	DCS	-	1.3	1.5	
		Vcont1,2=0V, Vcont3=2.6V	PCS	-	1.3	1.5	

BA01303

Triple Band(EGSM900/DCS1800/PCS1900) InGaP HBT Front-end module

OPERATION MODES AND CONTROL SIGNALS

Mode		Vband	Vcont1	Vcont2	Vcont3
EGSM_Tx		Low	High	Low	Low
DCS_Tx, PCS_Tx		High	Low	High	Low
EGSM_Rx		Low	Low	Low	Low
DCS_Rx		Low	Low	Low	Low
PCS_Rx		Low	Low	Low	High
Apply voltage	Low	0 - 0.8V	0 - 0.8V	0 - 0.8V	0 - 0.8V
	High	2.1 - 2.6V	2.4 - 2.8V	2.4 - 2.8V	2.4 - 2.8V

PACKAGE OUTLINE

