

Double cassette tape recorder system preamplifier

BA3426AS

The BA3426AS is a record/playback system preamplifier for radio cassette decks. It also has a CD input. It has three control switches for function and tape mode switching and mic on/off.

It requires far fewer external components than its predecessors which means simplified assembly and overall savings.

●Applications

Dual-cassette radio cassette players.

●Features

- 1) Built-in switch for recording/playback equalize.
- 2) Motor control output provided.
- 3) CD input.
- 4) Smoothing capacitors to suppress switching noise are not required.
- 5) Built-in bias oscillator transistor.

●Absolute maximum ratings (Ta = 25°C)

Parameter	Symbol	Limits	Unit
Power supply voltage	V _{CC}	9	V
Power dissipation	P _d	1250*1	mW
Operating temperature	T _{opr}	-10~+75	°C
Storage temperature	T _{stg}	-55~+125	°C

* Reduced by 12.5mW for each increase in Ta of 1°C over 25°C.

●Recommended operating conditions (Ta = 25°C)

Parameter	Symbol	Min.	Typ.	Max.	Unit
Power supply voltage	V _{CC}	4.5	—	7.0	V

● Block diagram

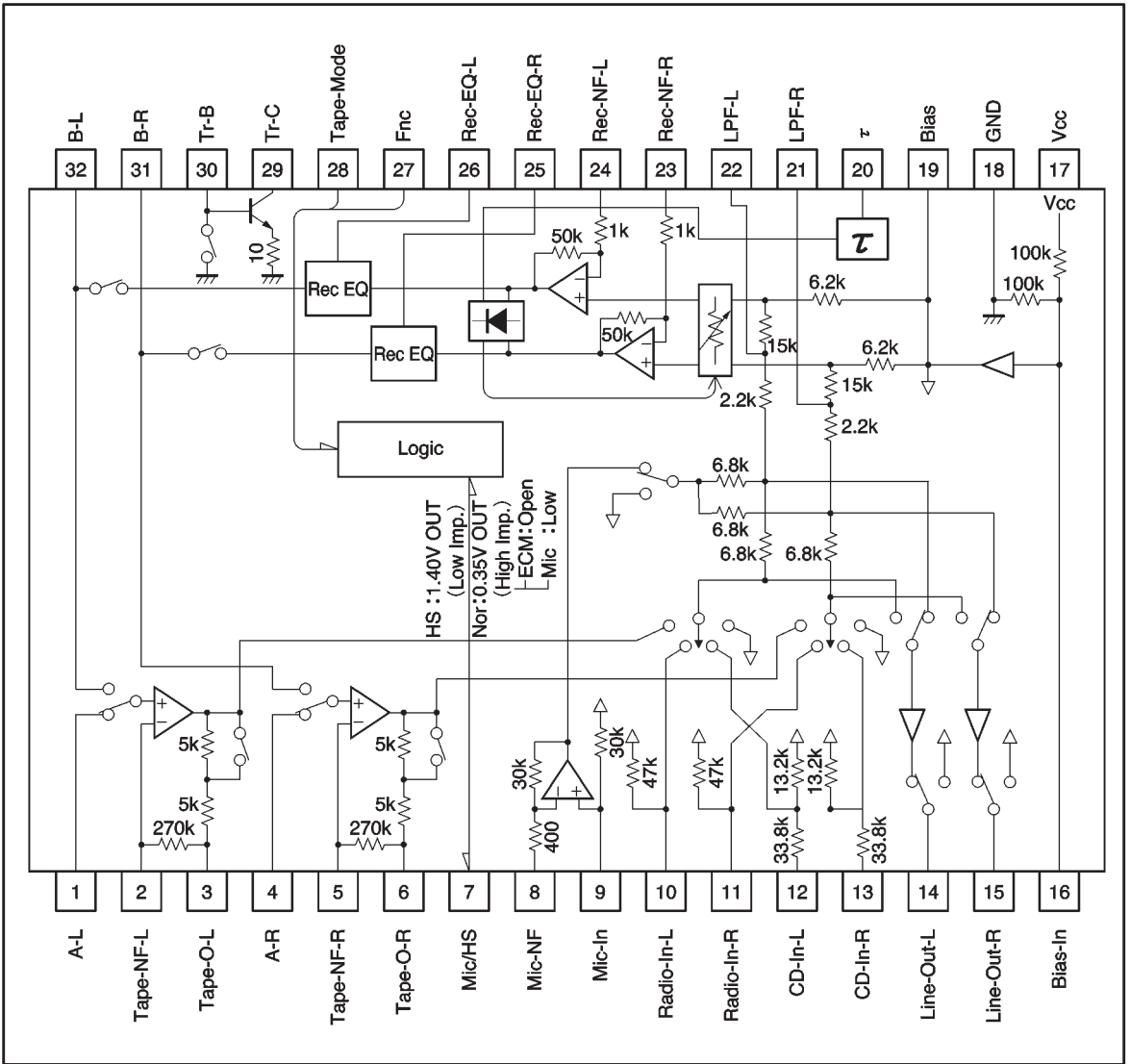

● Pin descriptions

Pin No.	Pin name	Function
1	A-L	Tape A input (L ch)
2	Tape-NF-L	Playback equalizer amplifier negative input (L ch)
3	Tape-O-L	Playback equalizer amplifier output (L ch)
4	A-R	Tape A input (R ch)
5	Tape-NF-R	Playback equalizer amplifier negative input (R ch)
6	Tape-O-R	Playback equalizer amplifier output (R ch)
7	Mic/HS	Int/Ext mic switch, motor control
8	Mic-NF	Microphone amplifier negative input
9	Mic-IN	Microphone amplifier input
10	Radio-IN-L	Radio input (L ch)
11	Radio-IN-R	Radio input (R ch)
12	CD-IN-L	CD input (L ch)
13	CD-IN-R	CD input (R ch)
14	Line-Out-L	Line amplifier (L ch)
15	Line-Out-R	Line amplifier (R ch)
16	Bias-IN	Bias input
17	Vcc	Power supply
18	GND	Substrate GND
19	Bias	Operating reference point
20	τ	Transient mute, ALC time constant
21	LPF-R	Low-pass filter (R ch)
22	LPF-L	Low-pass filter (L ch)
23	Rec-NF-R	ALC amplifier negative feedback (R ch)
24	Rec-NF-L	ALC amplifier negative feedback (L ch)
25	Rec-EQ-R	Recording equalizer amplifier negative feedback (R ch)
26	Rec-EQ-L	Recording equalizer amplifier negative feedback (L ch)
27	Fnc	Function switch
28	Tape-Mode	Tape mode switch
29	Tr-C	Bias oscillator transistor (collector)
30	Tr-B	Bias oscillator transistor (base)
31	B-R	Tape B input and recording equalizer amplifier output (R ch)
32	B-L	Tape B input and recording equalizer amplifier output (L ch)

- Electrical characteristics (unless otherwise noted, $T_a = 25^\circ\text{C}$, $V_{CC} = 5.5\text{V}$, $f = 1\text{kHz}$, $R_g = 680\Omega$,
Tape input = -66dBm , Mic. input = -50dBm , and Radio input = -23dBm ,
and CD input = -12dBm)

Parameter	Symbol	Min.	Typ.	Max.	Unit	Symbol*	Conditions
Quiescent current	I_Q	—	28	36	mA	TAE	
Voltage gain							
Mic ~Line	GvcML	28	31	34	dB	TNM	
Radio~Line	GvcRL	1	4	7	dB	RAE	
CD ~Line	GvcCL	-10	-7	-4	dB	CAE	
Radio~Rec	GvcRR	13	16	19	dB	RNE	
CD ~Rec	GvcCR	2	5	8	dB	CNE	
Tape ~Line	GvcTL1	54	57	60	dB	TAE	$V_{IN}=76\text{dBm}$, 315Hz
Tape ~Line	GvcTL2	41.6	44	46.4	dB	TAE	$V_{IN}=-63\text{dBm}$, 10kHz
Maximum output voltage						Mic input	
Line Out	V_{OML}	2.5	4.5	—	dBm	TNM	THD=1%
Rec Out	V_{OMR}	2.0	4.0	—	dBm	TNM	THD=3%, ALC OFF
Total harmonic distortion							
Mic ~Line	THD ML	—	0.08	0.5	%	TNM	
Radio~Line	THD RL	—	0.02	0.5	%	RNE	
CD ~Line	THD CL	—	0.02	0.5	%	CNE	
Radio~Rec	THD RR	—	0.2	0.7	%	RNE	ALC OFF
CD ~Rec	THD CR	—	0.2	0.7	%	CNE	ALC OFF
Tape ~Line	THD TL	—	0.1	0.7	%	TAE	
Input conversion noise voltage (Tape)	V_{NINT}	—	0.8	1.6	μV_{rms}	TAE	DIN AUDIO Line Out
Output noise voltage (CD)	V_{NOCD}	—	5	10	μV_{rms}	CAE	DIN AUDIO Line Out

Parameter	Symbol	Min.	Typ.	Max.	Unit	Conditions	
						Symbol*	
Rec EQ Amp f characteristic						CD Input	
Nor	ΔG_{vcNor}	4.6	7.0	9.4	dB	CNE	Measured at 10kHz (output voltage=0dB at f=1kHz)
HS	ΔG_{vcHS}	1.7	3.7	5.7	dB	CHE	Measured at 10kHz (output voltage=0dB at f=1kHz)
PB EQ Amp f characteristic	ΔG_{vcPB}	3.1	5.5	7.9	dB	D * E	* =Difference between N and H output levels at f=10kHz. Measured at Line Out.
L/R channel separation							
Radio~Line	CS _{LR} RL	55	66	—	dB	RNE	Vo=0dBm
CD ~Line	CS _{LR} CL	55	66	—	dB	CNE	Vo=0dBm
Tape ~Line	CS _{LR} TL	50	62	—	dB	TAE	Vo=0dBm
Radio~Rec	CS _{LR} RR	50	54	—	dB	RNE	Vo=-6dBm
CD ~Rec	CS _{LR} RL	50	54	—	dB	CNE	Vo=-6dBm
A/B crosstalk	CT _{AB}	—	-67	-60	dBm	T * E	With (TAE) Tape A input, and Line Out=0dBm, switch to (TBE) and measure the Line Out level.
PB→REC crosstalk	CT _{RP}	—	-92	-80	dBm	C * E	With (CNE) CD input, ALC off, and Rec Out=0dBm, switch ALC on, switch to (CAE) and measure the Rec Out level (tape B).
Mic mute level	MM	—	-66	-55	dBm	TN *	With (TNM) Mic input, and Line Out =0dBm, switch to (TNE) and measure the Line Out level.
ALC distortion	THD _{ALC}	—	0.5	1	%	TNE	Mic input=-40dBm Measured at Rec Out.
ALC level	V _{ALC}	-5.7	-3.7	-1.7	dBm	TNE	Mic input=-30dBm Measured at Rec Out.
ALC balance	CB _{ALC}	—	0	2.5	dB	TNE	Mic input=-30dBm Measured at Rec Out.
ALC current capacity	I _{ALC}	4.0	7.7	—	mA	TNE	Mic input=-30dBm Average τ pin output current.

Parameter		Symbol	Min.	Typ.	Max.	Unit	Symbol*	Conditions
Mic/HS pin output voltage	HS	VHS	1.0	1.4	—	V	CH—	Current: 300 μ A
	Nor	VNor	—	0.38	0.43		CNE	
Mic/HS pin threshold resistance	ECM	RECM	—	50	100	k Ω		
	Mic	RMic	30	50	—			
Function pin threshold voltage	Dubbing	V _F R	0.86V _{cc}	—	V _{cc}	V		
	Tape	V _F C	0.57V _{cc}	—	0.82V _{cc}			
	CD	V _F D	0.27V _{cc}	—	0.53V _{cc}			
	Radio	V _F T	0.07V _{cc}	—	0.23V _{cc}			
Tape mode pin threshold voltage	Nor Rec	V _T N	0.86V _{cc}	—	V _{cc}	V		
	HS Rec	V _T H	0.57V _{cc}	—	0.82V _{cc}			
	B mechanism	V _T B	0.31V _{cc}	—	0.53V _{cc}			
	A mechanism	V _T A	0.09V _{cc}	—	0.27V _{cc}			
Bias oscillator transistor saturation voltage		V _{SAT}	—	0.24	0.35	V	CNE	Current: 10mA, 10k Ω resistor connected between V _{cc} and pin 30.

* Meaning of the abbreviations in the symbol column

Pin	Symbol	Meaning	Applied voltage or state
7pin	E	ECM	Open
	M	Mic	Connected to GND via 10k Ω
28pin	N	Nor Rec	Connected to V _{cc} via 10k Ω
	H	HS Rec	Connected to V _{cc} via 10k Ω and to GND via 22k Ω
	B	B mechanism	Connected to V _{cc} via 6.9k Ω (22k in parallel with 10k) and to GND via 4.7k Ω
	A	A mechanism	Connected to V _{cc} via 22k Ω and to GND via 4.7k Ω
27pin	D	Dubbing	Connected to V _{cc} via 10k Ω
	T	Tape	Connected to V _{cc} via 10k Ω and to GND via 22k Ω
	C	CD	Connected to V _{cc} via 10k Ω and to GND via 6.8k Ω
	R	Radio	Connected to V _{cc} via 10k Ω and to GND via 1k Ω

● Measurement circuit

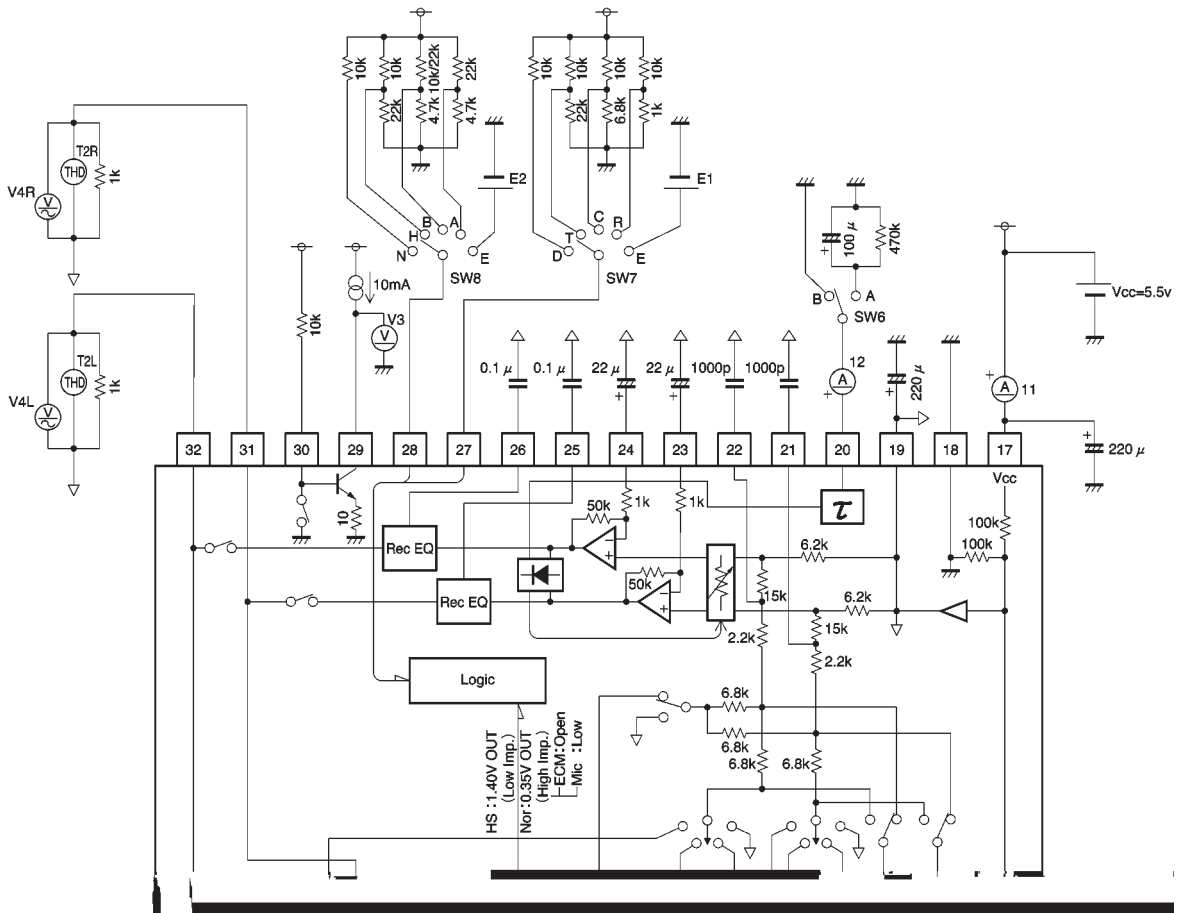

●Circuit operation

(1) Control pins

The control pin inputs and the corresponding states of the various inputs and outputs are summarized in the input/output pin status table that follows.

Control pin inputs and corresponding input/output pin states

Control Pin			Input/Output Condition										Bias OSC Tr.	HS Out	Transient mute	Set Mode	
Function	Tape Mode	ECM/Mic Open=ECM Low=Mic	A In		B In		CD In		Radio In		Mic In						
			Line Out	Rec Out	Line Out	Rec Out	Line Out	Rec Out	Line Out	Rec Out	Line Out	Rec Out	Line Out	Rec Out			
Dub	Nor Rec	ECM	●	●	×	×	×	×	×	×	×	×	on	Low		Dubbing	
		Mic	●	●	×	×	×	×	×	×	●	●	on	Low	on	Mix-Dubbing	
	HS-R	ECM	●HS	●HS	×	×	×	×	×	×	×	×	on	High	on	HS-Dubbing	
	B PB	ECM	×	open	●	open	×	open	×	open	×	open	off	Low	on	B-Play	
		Mic	×	open	●	open	×	open	×	open	●	open	off	Low	on	B-Mix-Play	
	A PB	ECM	●	open	×	open	×	open	×	open	×	open	off	Low	on	A-Play	
Mic		●	open	×	open	×	open	×	open	●	open	off	Low	on	A-Mix-Play		
Tape	Nor Rec	ECM	×	×	×	×	×	×	×	×	×	●	on	Low	on	ECM-Rec	
		Mic	×	×	×	×	×	×	×	×	●	●	on	Low	on	Mic-Rec	
	HS Rec	ECM	×	×	×	×	×	×	×	×	×	●	on	Low	on	ECM-Rec	
		Mic	×	×	×	×	×	×	×	×	●	●	on	Low	on	Mic-Rec	
	B PB	ECM	×	open	●	open	×	open	×	open	×	open	off	Low	on	B-Play	
		Mic	×	open	●	open	×	open	×	open	●	open	off	Low	on	B-Mix-Play	
	A PB	ECM	●	open	×	open	×	open	×	open	×	open	off	Low	on	A-Play	
		Mic	●	open	×	open	×	open	×	open	●	open	off	Low	on	A-Mix-Play	
	CD	Nor Rec	ECM	×	×	×	×	●	●	×	×	×	×	on	Low	*	CD-Dubbing
			Mic	×	×	×	×	●	●	×	×	●	●	on	Low	*	CD-Mix-Dubbing
		HS-R	ECM	×	×	×	×	●	●HS	×	×	×	×	on	High	*	CD-HS-Dubbing
		B PB	ECM	×	open	×	open	●	open	×	open	×	open	off	Low	*	CD-Play
Mic			×	open	×	open	●	open	×	open	●	open	off	Low	*	CD-Mix-Play	
A PB		ECM	×	open	×	open	●	open	×	open	×	open	off	Low	*	CD-Play	
	Mic	×	open	×	open	●	open	×	open	●	open	off	Low	*	CD-Mix-Play		
Radio	Nor Rec	ECM	×	×	×	×	×	×	●	●	×	×	on	Low	*	Rad-Rec	
		Mic	×	×	×	×	×	×	●	●	●	●	on	Low	*	Rad-Mix-Rec	
	HS Rec	ECM	×	×	×	×	×	×	●	●	×	×	on	Low	*	Rad-Rec	
		Mic	×	×	×	×	×	×	●	●	●	●	on	Low	*	Rad-Mix-Rec	
	B PB	ECM	×	open	×	open	×	open	●	open	×	open	off	Low	*	Rad-Play	
		Mic	×	open	×	open	×	open	●	open	●	open	off	Low	*	Rad-Mix-Play	
	A PB	ECM	×	open	×	open	×	open	●	open	×	open	off	Low	*	Rad-Play	
		Mic	×	open	×	open	×	open	●	open	●	open	off	Low	*	Rad-Mix-Play	

* Only the A-PLAY Y/B-PLAY switch goes off.

● :Corresponding signal is output.

●HS:The corresponding signal has the high-speed mode equalizer characteristic applied and is output.

× :Corresponding signal is output.

open:In the open (high impedance) state, no signal is output from output pin.

●Application example 1

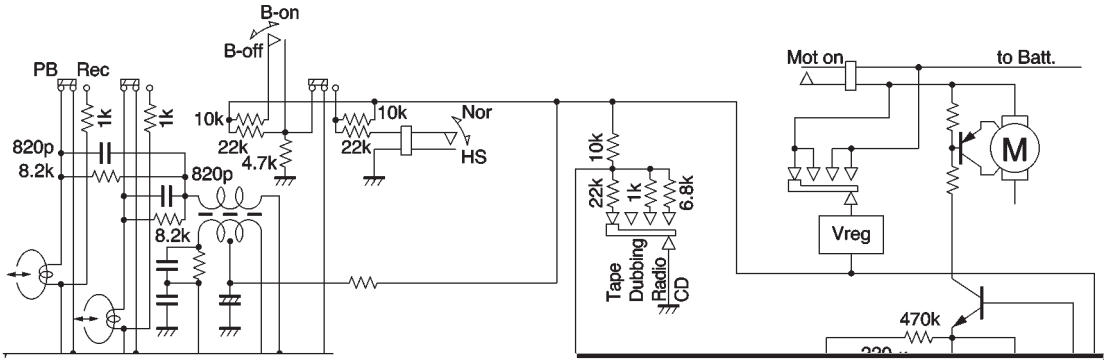

●Application example 2

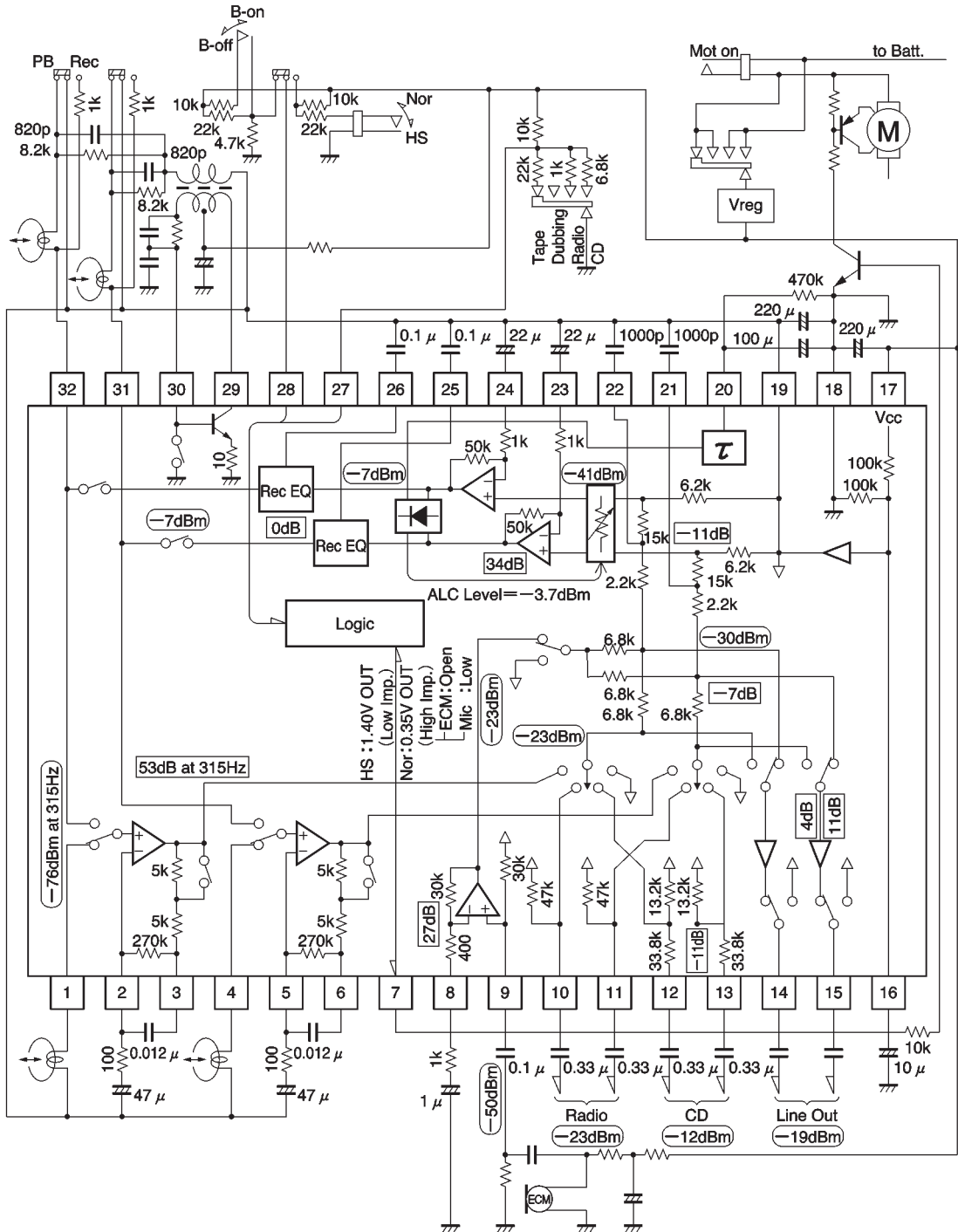

Fig. 3

● Operation notes

(1) Amplifier oscillation

As the BA3426AS incorporates dual-cassette dubbing functions on a single IC, it has extremely high input/output gain. In particular, in normal-speed mode, the gain at around the recording equalizer peaking characteristic frequency is about 70dB. The phases of the input and output are reversed to reduce the chance of oscillation due to influence of the PCB pattern, but due consideration must be given to the PCB pattern design to prevent oscillation. In particular, the PCB tracks to the Tape A pins (pins 1 and 4) and Tape B pins (pins 31 and 32) should be sufficiently far apart that there is no coupling capacitance between them, or they should be shielded by having a GND or bias track between them.

(2) Strong RF signals

To prevent signal mixing due to strong electric fields, connect a capacitor (of a few hundred pF) to each input pin. These must be connected close to the pins of the IC to have any effect. Design the PCB track layout so that the capacitors can be connected as close to the base of the pins as possible.

● Electrical characteristics curves

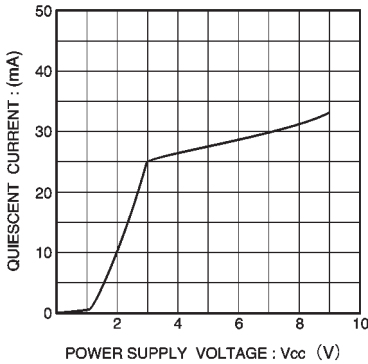

Fig. 4 Quiescent current vs. power supply voltage

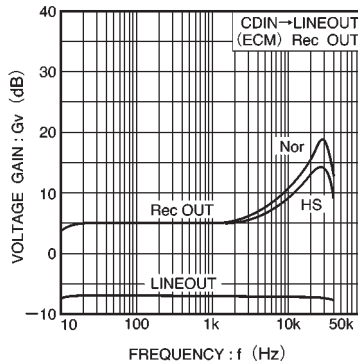

Fig. 5 Voltage gain vs. frequency

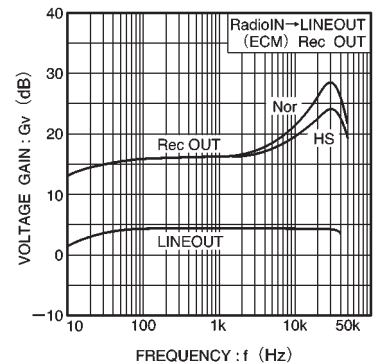

Fig. 6 Voltage gain vs. frequency

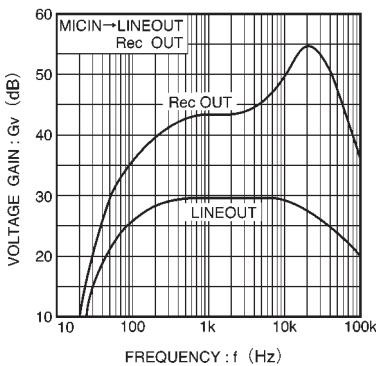

Fig. 7 Voltage gain vs. frequency

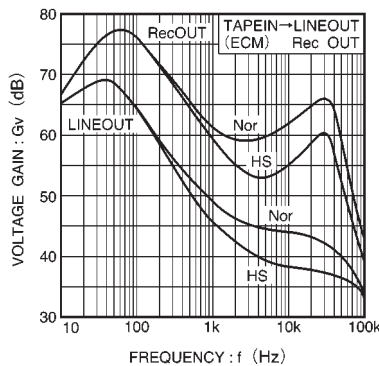

Fig. 8 Voltage gain vs. frequency

● External dimensions (Units: mm)

