

High-definition sound processor

BA3880S

The BA3880S is a sound processor IC that performs phase and harmonic compensation on audio signals to accurately reproduce the "rise" section of audio signals that determines the characteristics of the sound, and thus reproduce the original recording as naturally as possible.

●Applications

Component stereo systems, radio cassette players, car stereo systems, televisions, VCRs, and active speakers.

●Features

- 1) Corrects distortion in the rising section of audio signals that results from miss-matched speakers and amplifiers, and reproduces the original sound faithfully.
- 2) To allow application with all types of speakers and sources, the clarity can be adjusted using DC control.
- 3) DC control provided for selection of either processor mode or bypass mode.
- 4) Bass boost fixed internally to 4dB.

●Absolute maximum ratings (Ta = 25°C)

Parameter	Symbol	Limits	Unit
Power supply voltage	V _{CC}	11	V
Power dissipation	P _d	1000 *	mW
Operating temperature	T _{opr}	-40~+85	°C
Storage temperature	T _{stg}	-55~+125	°C

* Reduced by 10mW for each increase in Ta of 1°C over 25°C.

●Recommended operating conditions

Parameter	Symbol	Limits	Unit
Power supply voltage	V _{CC}	5.4~10.8	V

● Block diagram

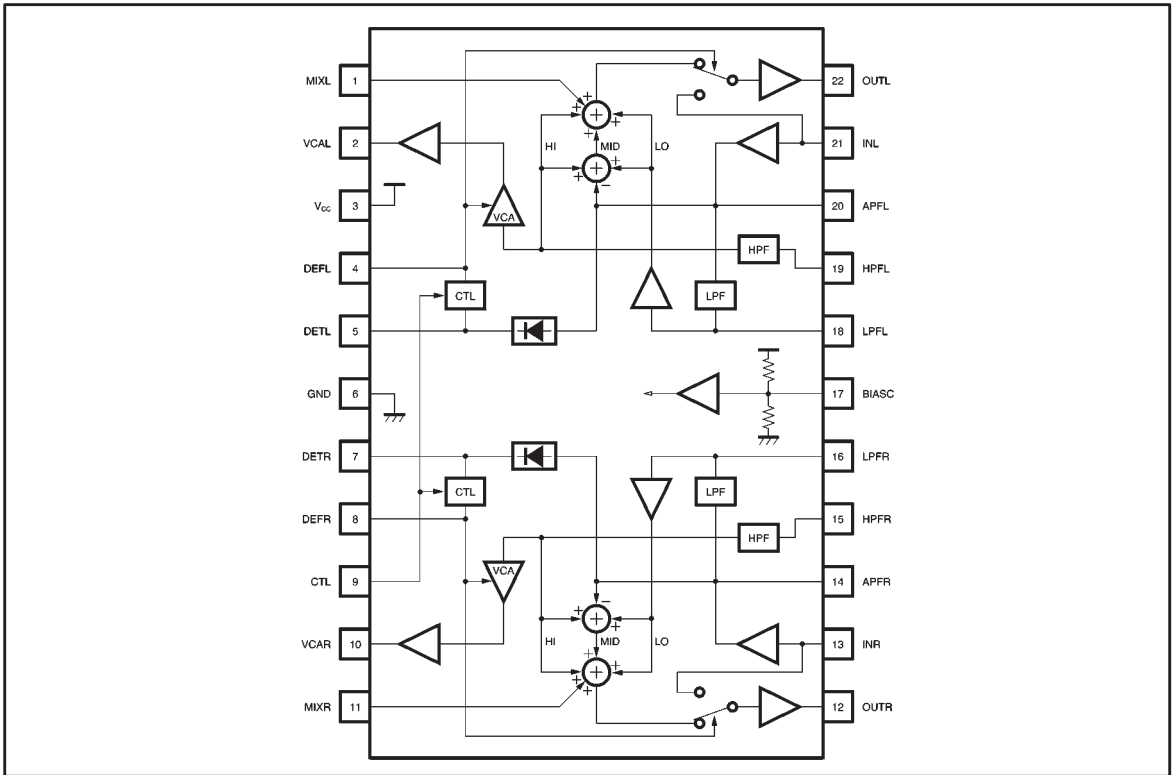

- Electrical characteristics(unless otherwise noted, $T_a = 25^\circ\text{C}$, $V_{CC} = 9\text{V}$, $f_{IN} = 1\text{kHz}$, $V_{IN} = 200\text{mV}_{rms}$,
 $R_g = 600\Omega$, $R_L = 100\text{k}\Omega$ and $V_{CTL} = 4.5\text{V}$)

Parameter	Symbol	Min.	Typ.	Max.	Unit	Conditions
Circuit current	I_{CC}	4.2	6.2	9.3	mA	$V_{IN}=0\text{V}_{rms}$
Voltage gain 1	G_{V1}	-2.0	0	2.0	dB	$V_{CTL}=9\text{V}$
Voltage gain 2	G_{V2}	-2.5	-0.5	1.5	dB	
Voltage gain 3	G_{V3}	-1.0	1.0	3.0	dB	$f_{IN}=10\text{kHz}$
Voltage gain 4	G_{V4}	9.0	11.0	13.0	dB	$f_{IN}=10\text{kHz}$, $V_{CTL}=0\text{V}$
Voltage gain 5	G_{V5}	—	4.0	—	dB	$f_{IN}=50\text{Hz}$
Channel balance	CB	-2.0	0	2.0	dB	$f_{IN}=10\text{kHz}$, $V_{CTL}=0\text{V}$
Maximum output voltage	V_{OM}	2.0	2.3	—	V_{rms}	THD=1%
Output noise voltage 1	V_{NO1}	—	2	10	μV_{rms}	$R_g=0\Omega$, DIN AUDIO, $V_{CTL}=9\text{V}$
Output noise voltage 2	V_{NO2}	—	16	70	μV_{rms}	$R_g=0\Omega$, DIN AUDIO
Total harmonic distortion 1	THD ₁	—	0.005	0.05	%	400Hz~30kHz BPF, $V_{CTL}=9\text{V}$
Total harmonic distortion 2	THD ₂	—	0.04	0.4	%	400Hz~30kHz BPF
Channel separation	CS	—	-67	-60	dB	$V_{IN}=1\text{V}_{rms}$
Ripple rejection ratio	RR	60	68	—	dB	$R_g=0\Omega$, $f_R=100\text{Hz}$, $V_R=100\text{mV}_{rms}$

*Note : When $V_{CTL} = 9\text{V}$, the IC is in bypass mode (through operations).

When $V_{CTL} = 4.5\text{V}$, the IC is in processor mode (enhance operations) with minimum definition level.

When $V_{CTL} = 0\text{V}$, the IC is in processor mode (enhance operations) with maximum definition level.

● Measurement circuit

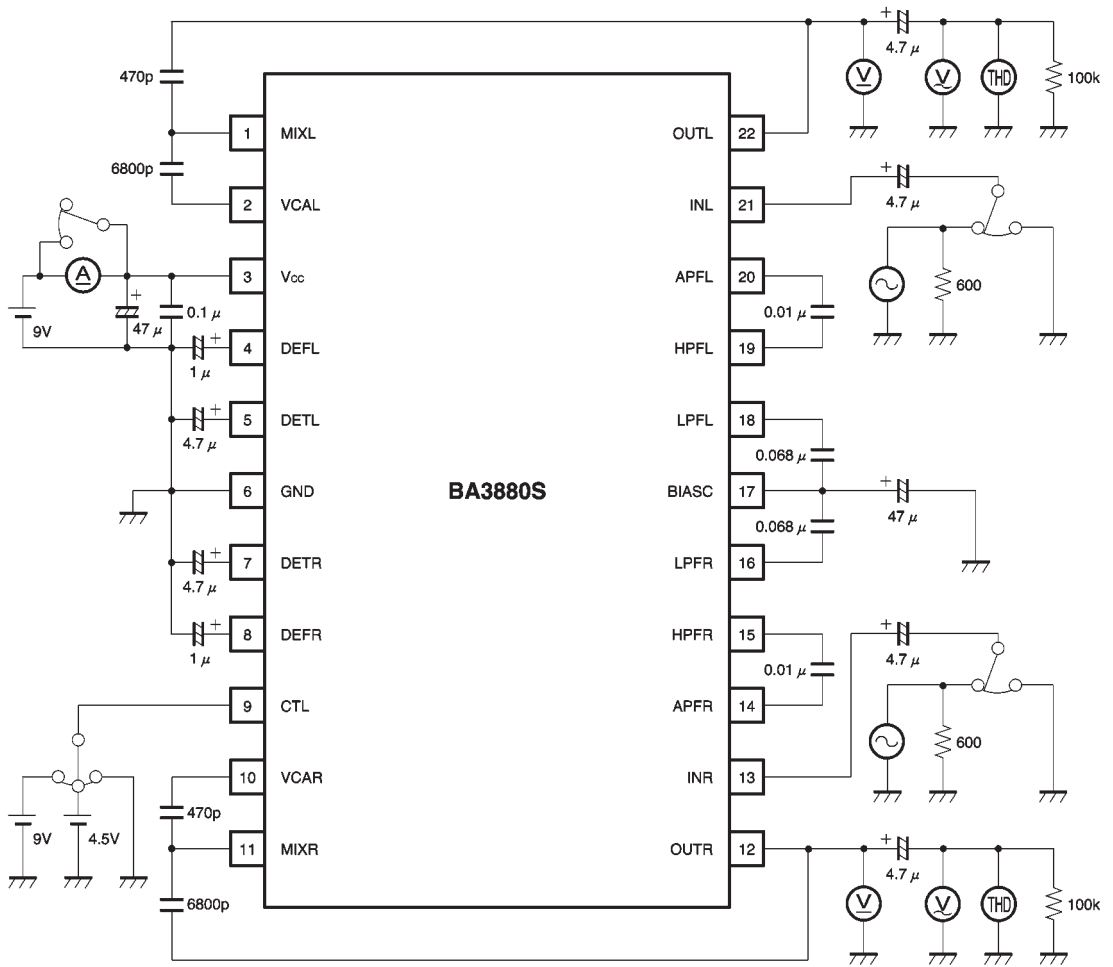

(Units) R : Ω
C : F

Fig. 1

● Circuit operation

The BA3880S high-definition sound processor system IC treats the amplifier and speakers as a total audio system, and performs signal processing at the amplifier input stage to accurately reproduce the rise sections of audio signals that determine the characteristics of sound, and ensure that the replayed audio is as close to the original sound and as natural sounding as possible.

Problems relating to playback of sound on audio systems.

With naturally-generated sound, high-frequency harmonic components generally occur first, followed by the fundamental frequency components. This also applies to the attack section of the sound that characterizes many musical instruments. It is the amplitude component that gives form to the frequency component and envelope at the rising point of sound, and this expresses the characteristics of the sound. Therefore, when replaying audio on audio playback systems, it is extremely important that

the rise section of the signal be expressed accurately with respect to the original sound.

However, there is inevitable mismatching between the speakers and amplifiers in current audio systems. Solid-state power amplifiers use negative feedback techniques and operate off a fixed voltage supply, but as speakers are a current element, mismatching in the system inevitably occurs. In addition, the speaker impedance characteristics are strongly influenced by the electrical reactance of the voice coil, and the mechanical reactance of the cone assembly. As a result of this, distortion is generated in the rising sections of audio signals, causing phase shift in the reproduced sound. In addition, impedance increases in the treble region which reduces the speaker amplitude and reduces the harmonic component, and as a result there is a tendency to masking of large mid-frequency signal components that follow, and this makes it difficult to reproduce the rising sections of the sound.

● Operating principle

To solve the problems described above, the BA3880S performs the audio signal processing described below.

Phase shift compensation

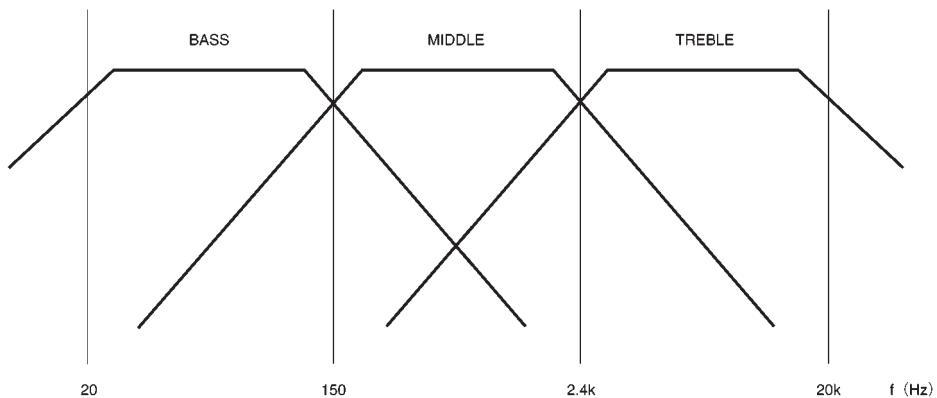

The input signal is separated into three regions: bass (20 Hz to 150 Hz), middle (150 Hz to 2.4kHz) and treble (2.4kHz to 20kHz). These regions are then joined again with the middle and treble regions phase shifted -180° and -360° respectively with respect to the bass signal. This phase shift adjusts the delay time characteristic for each band and minimizes the distortion of the rising section of the audio signal.

Amplitude compensation (harmonic compensation)

To maintain appropriate auditory balance for the treble region that is made up of harmonic components, a high-speed detector and high-performance VCA circuit are used for amplitude control of the treble component. The amount of compensation is determined from a calculation performed based on the DC level input to the CTL pin, and the DC level detected from the input signal. The internal control signal obtained from this calculation compensates the amplitude of the treble component input to the VCA. This amplitude compensation recovers the harmonic component, and improves the reproduction clarity (definition level) of instruments and vocals.

Bass boost

To maintain good balance with the dynamically changing treble component, the bass component is boosted. The bass boost is fixed at 4dB (typ.) internally, and cannot be adjusted.

Mode switch

The DC voltage on the CTL pin can be used to switch the IC between processing mode and bypass mode. When processing mode is selected, the audio signal is enhanced using the compensation circuits described above before being output. When bypass mode is selected, the signal bypasses all of the compensation circuits, and only passes through a buffer amplifier before output.

External components

The frequency characteristic in processing mode with maximum definition level is given below.

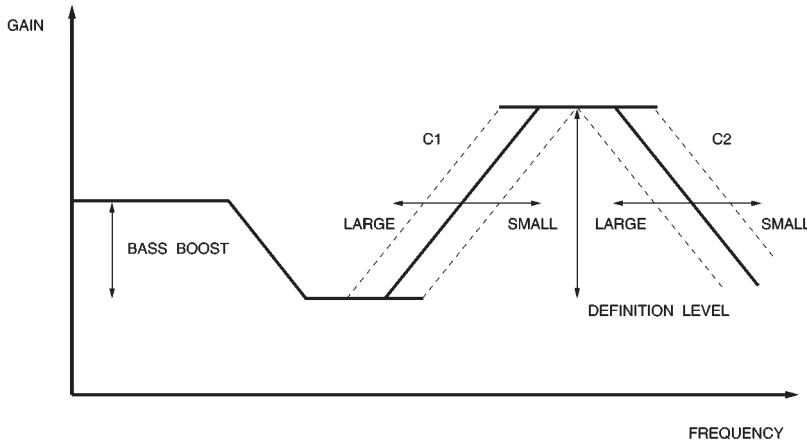

- C1: External capacitor connected between the VCA and MIX pins (6800pF in the application circuit).
- C2: External capacitor connected between the OUT and MIX pins (470pF in the application circuit).

As indicated in the diagram, capacitors C1 and C2 determine the treble component cutoff frequency. By varying the values of these components, the frequency characteristic can be changed as indicated by the dotted line in the diagram. This varies the balance of the harmonic component, and is an important factor in determining the tone quality.

Control table

Item	Threshold level	Mode setting	Definition level
V _{CTL}	V _{CC}	Recommended setting range for bypass mode 0.7 × V _{CC}	Min. (1dB Typ.)
	0.6 × V _{CC}		
	0V (GND)	Recommended setting range for processor mode 0.5 × V _{CC}	Max. (11dB Typ.)

● Application example

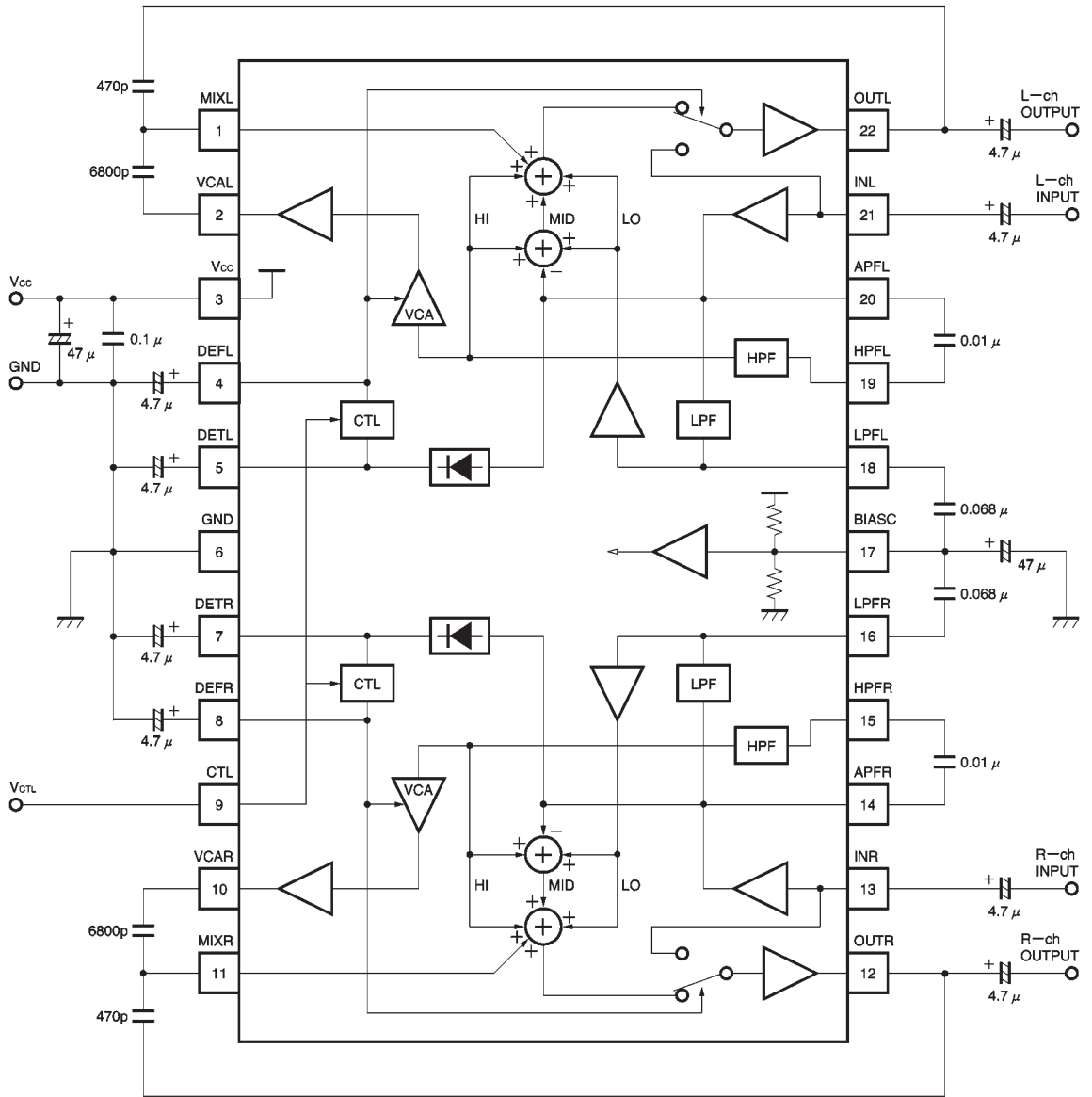

(Units) R : Ω
C : F

Fig. 2

● Operation notes

(1) Control pin (CTL)

The level of the DC voltage applied to the control pin should be in the range 0V to V_{CC} . Appropriate switching may not be possible in the region of the threshold voltage. Allow sufficient margin when setting this voltage.

(2) Recommended operating range

Provided the IC is operated within the operating temperature range and within the recommended operating conditions, the general circuit functions are guaranteed to operate correctly, and there will not be significant changes in the electrical characteristics.

(3) Application example

Provided the circuit constants in the application example

are used, the application circuit should function correctly. However, we recommend that you confirm the characteristics of the circuit in actual use, and take note of the cautionary items described above. If you change the circuit constants, check both the static and transient characteristics of the circuit, and allow sufficient margin to accommodate variations in both the IC and the external components.

(4) License

This IC is manufactured under license from BBE Sound Inc. (U.S.A.). A license agreement with BBE Sound Inc. is required to use this component.

● Electrical characteristics curves

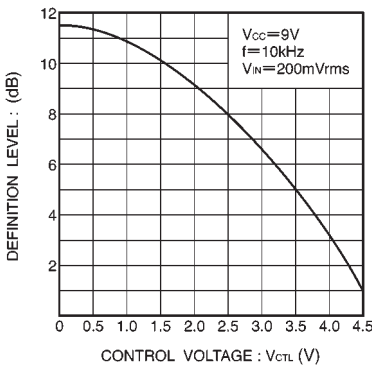

Fig. 3 Definition level vs. control voltage

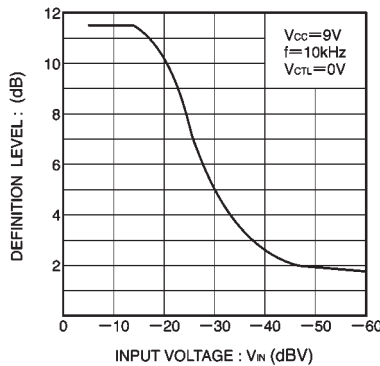
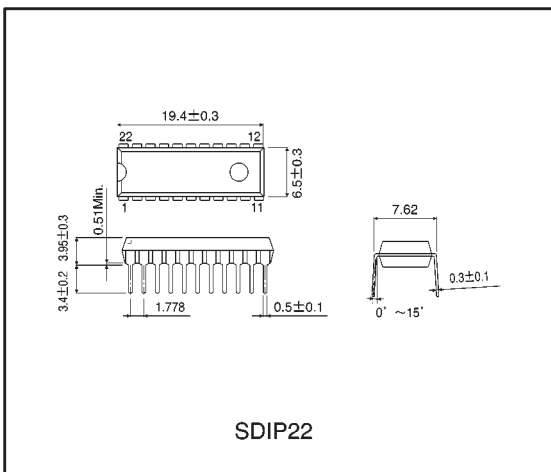

Fig. 4 Definition level vs. input voltage

● External dimensions (Units: mm)



Notes

- No technical content pages of this document may be reproduced in any form or transmitted by any means without prior permission of ROHM CO.,LTD.
- The contents described herein are subject to change without notice. The specifications for the product described in this document are for reference only. Upon actual use, therefore, please request that specifications to be separately delivered.
- Application circuit diagrams and circuit constants contained herein are shown as examples of standard use and operation. Please pay careful attention to the peripheral conditions when designing circuits and deciding upon circuit constants in the set.
- Any data, including, but not limited to application circuit diagrams information, described herein are intended only as illustrations of such devices and not as the specifications for such devices. ROHM CO.,LTD. disclaims any warranty that any use of such devices shall be free from infringement of any third party's intellectual property rights or other proprietary rights, and further, assumes no liability of whatsoever nature in the event of any such infringement, or arising from or connected with or related to the use of such devices.
- Upon the sale of any such devices, other than for buyer's right to use such devices itself, resell or otherwise dispose of the same, no express or implied right or license to practice or commercially exploit any intellectual property rights or other proprietary rights owned or controlled by
- ROHM CO., LTD. is granted to any such buyer.
- Products listed in this document use silicon as a basic material.
Products listed in this document are no antiradiation design.

The products listed in this document are designed to be used with ordinary electronic equipment or devices (such as audio visual equipment, office-automation equipment, communications devices, electrical appliances and electronic toys).

Should you intend to use these products with equipment or devices which require an extremely high level of reliability and the malfunction of which would directly endanger human life (such as medical instruments, transportation equipment, aerospace machinery, nuclear-reactor controllers, fuel controllers and other safety devices), please be sure to consult with our sales representative in advance.

About Export Control Order in Japan

Products described herein are the objects of controlled goods in Annex 1 (Item 16) of Export Trade Control Order in Japan.

In case of export from Japan, please confirm if it applies to "objective" criteria or an "informed" (by MITI clause) on the basis of "catch all controls for Non-Proliferation of Weapons of Mass Destruction.