

Li-SO₂ primary battery system

BA 5800 A/U

Assembled from 2 LO 26 SX cells connected in series.



Key features

- A non-replaceable fuse is incorporated in the negative leg.
- A normally closed thermal fuse (TCO) is incorporated in the battery. It is non-replaceable and non-resettable.
- A diode is incorporated to prevent charging or flow of current into the battery.
- A device consisting of a manually activated switch and resistor designed to discharge the battery to 0 V is built into the battery.
- Made in the USA

Typical applications

- AN/PSN-11 GPS
- AN/PSN-10 (V) GPS
- Chemical Agent Monitor

Electrical Characteristics

Typical OCV (V)	6.0
Nominal voltage (at 500mA) (V)	5.3
Cut-off (V)	4.0
Typical Capacity (Ah) +21 °C / + 70 °F (at 250 mA discharge current)	7.5
Operating temperature	-40° C to 71° C -40° F to 160° F
Storage	Recommended max Possible
	+35°C/ +95°F -40° C to 71° C / -40° F to 160° F

Physical Characteristics

Typical Weight (g/oz)	220 / 7.76
Weight of Li metal content (g/oz)	4.8 / 0.17
Max. OD (mm/ in)	35.51/ 1.398
Max. Height (mm/ in)	128.5 / 5.059
Battery Case	Plastic

References

Reference specifications	MIL PRF 49471B (CR) or Saft Standard Specifications
NSN Reference	6135-01-440-7774



saft

BA 5800 A/U dimensions

*All measurements in inches

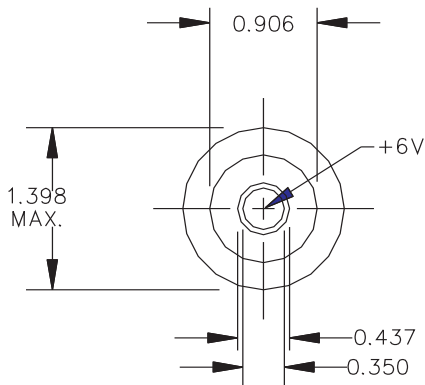
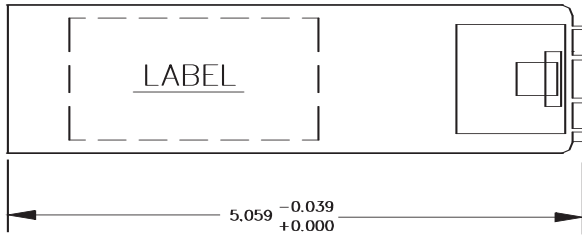

Electrical schematic

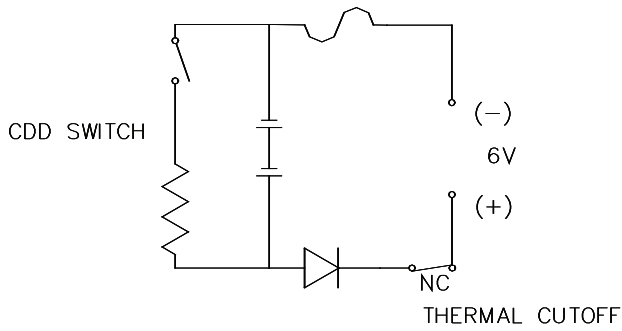

Capacity vs rate at various temperatures

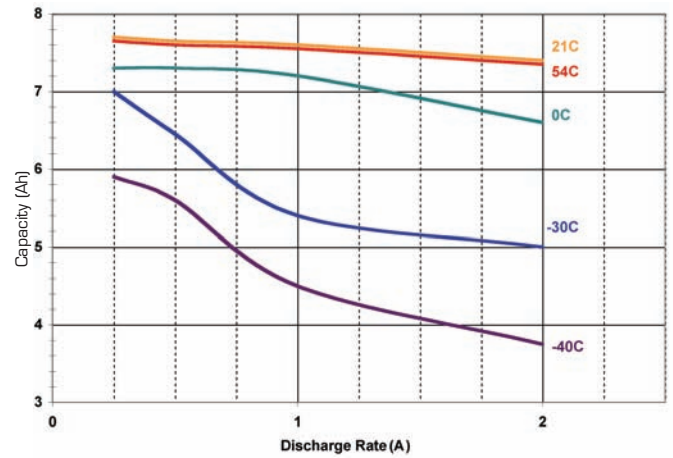

2 A discharge typical curves at various temperatures

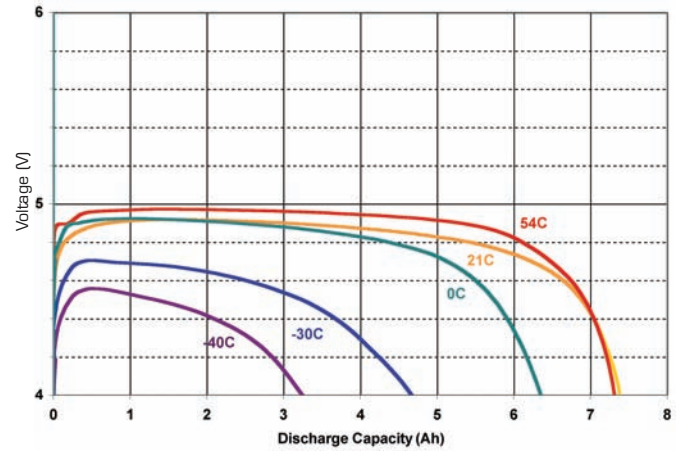

Typical discharge curves at various rates at +21°C/+70°F

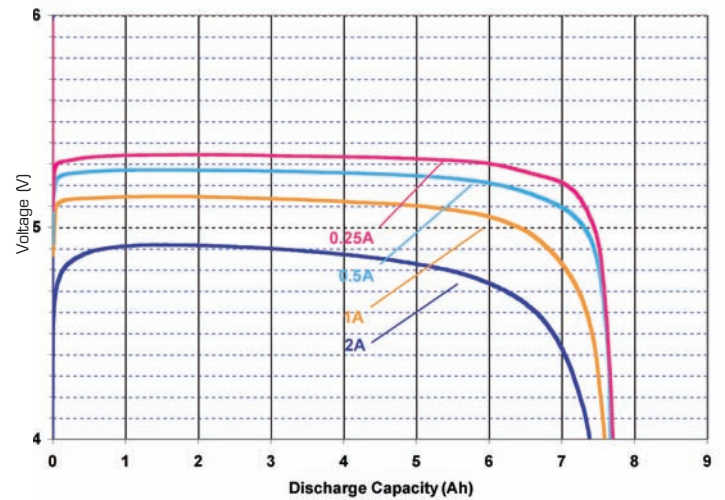

Saft Specialty Battery Group

12, rue Sadi Carnot
93170 Bagnole - France
Tel: +33 (0)1 49 93 19 18
Fax: +33 (0)1 49 93 19 69

313 Crescent Street
Valdese NC 28690 - USA
Tel: +1 (828) 874 4111
Fax: +1 (828) 874 2431

www.saftbatteries.com

Doc N° 31071-2-0306

Data in this document is subject to change without notice and becomes contractual only after written confirmation.

