

# BA6149LS

## Regulator, switching, 6 outputs

The BA6149LS is an IC that consists of six switching regulator circuits

### Dimensions (Units : mm)

BA6149LS (SZIP24)

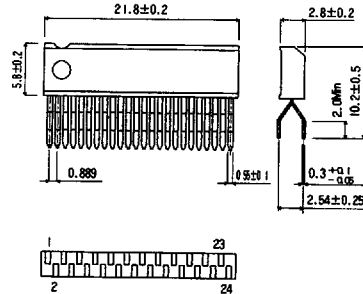

### Features

- available in an SZIP24 package
- control circuits for all regulator circuits are contained in the IC
- high efficiency pulse width modulation system is used
- triangular wave generator produces a very clean stable output
- six output voltages
- output voltages can be switched on and off (except 5 V output)

### Block diagram

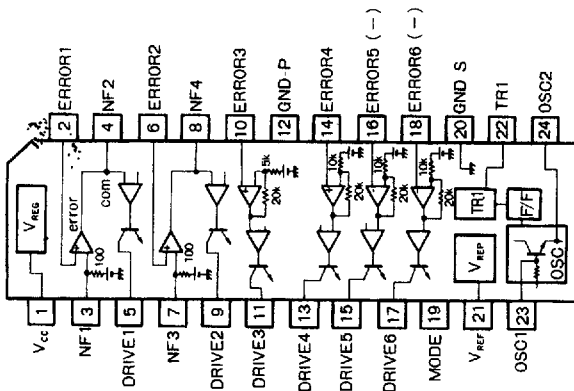

**Absolute maximum ratings ( $T_a = 25^\circ\text{C}$ )**

Parameter	Symbol	Limits	Unit	Conditions
Power supply voltage	$V_{CC}$	20	V	
Power dissipation	$P_d$	500	mW	Reduce power by 5 mW/°C for each degree above 25°C.
Drive current	$I_d$	30	mA	
Operational temperature	$T_{opr}$	-10 ~ +70	°C	
Storage temperature	$T_{stg}$	-25 ~ +125	°C	

**Electrical characteristics ( $T_a = 25^\circ\text{C}$ ,  $V_{CC} = 12\text{ V}$ ) (Sheet 1 of 2)**

Parameter	Symbol	Min	Typical	Max	Unit	Conditions
Power supply voltage	$V_{CC}$	8		18	V	
Circuit current	$I_{CC}$		7	11	mA	
Reference voltage	$V_{ref}$	2.38	2.53	2.68	V	
Triangular wave oscillation frequency	$f_T$	100.88	101.88	102.88	kHz	$f_0 = 815\text{ kHz}$
5 V system output voltage	$V_{O5}$	4.7	5.0	5.3	V	$I_L = 227\text{ mA}$
9 V system output voltage	$V_{O9}$	8.60	9.15	9.70	V	$I_L = 100\text{ mA}$
M1 system output voltage	$V_{CY}$	4.5	5	5.5	V	$I_L = 100\text{ mA}$
M2 system output voltage	$V_{CA}$	3.0	3.5	4.0	V	$I_L = 50\text{ mA}$
M3 system output voltage	$V_{SR}$	3.0	3.5	4.0	V	$I_L = 55\text{ mA}$
M4 system output voltage	$V_{TR}$	3.0	3.5	4.0	V	$I_L = 200\text{ mA}$
M1 input regulation	$V_{r1}$	40	80	160	mV	$I_L = 100\text{ mA}$ , $10 \leq V_{CC} \leq 16$
M2 input regulation	$V_{r2}$	30	60	120	mV	$I_L = 50\text{ mA}$ , $10 \leq V_{CC} \leq 16$
M3 input regulation	$V_{r3}$	30	60	120	mV	$I_L = 55\text{ mA}$ , $10 \leq V_{CC} \leq 16$
M4 input regulation	$V_{r4}$	30	60	120	mV	$I_L = 200\text{ mA}$ , $10 \leq V_{CC} \leq 16$
Low level power-saving mode	$V_L$	0		1.5	V	
High level power-saving mode	$V_H$	3.5		6	V	All output voltage < 0.5 V except for $V_{O5}$
9 V system error amplifier open loop gain	$G_{O9}$	70			dB	
5 V system error amplifier open loop gain	$V_{O5}$	70			dB	
9 V system ripple	$R_{P9}$		2	5	mV <sub>pk-pk</sub>	$I_L = 100\text{ mA}$
5 V system ripple	$R_{P5}$		2	5	mV <sub>pk-pk</sub>	$I_L = 227\text{ mA}$
M system ripple	$R_{PM}$		30	50	mV <sub>pk-pk</sub>	$I_L = 100\text{ mA}$

Electrical characteristics ( $T_a = 25^\circ\text{C}$ ,  $V_{CC} = 12\text{ V}$ ) (Sheet 2 of 2)

Parameter	Symbol	Min	Typical	Max	Unit	Conditions
9 V system error amplifier closed loop gain	$G_{V9}$	35	38	41	dB	$R_N = 10\text{ k}\Omega$ , $f = 100\text{ kHz}$
5 V system error amplifier closed loop gain	$G_{V5}$	34.5	37.5	40.5	dB	$R_N = 10\text{ k}\Omega$ , $f = 100\text{ kHz}$
9 V system error amplifier phase characteristics	$\phi_9$		55	70	deg	$f = 100\text{ kHz}$
5 V system error amplifier phase characteristics	$\phi_5$		55	70	deg	$f = 100\text{ kHz}$

## Precautions for use

## Oscillation frequency

The maximum oscillation frequency ( $f_{OMax}$ ) is about 850 kHz. The actual triangular frequency ( $f_T$ ) is  $f_O/8$ .

Make sure to set the resistance  $R_T$  such that in the triangular wave,  $t_a \geq 67\%$ , as shown in the figure below.

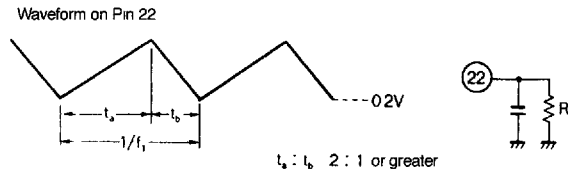

## DC gain

The 5 V and 9 V system error amplifier DC gain is determined by the feedback resistor ( $R_1$ ).

Make sure to use a resistor such that  $10\text{ k}\Omega \leq R_1 \leq 100\text{ k}\Omega$ .

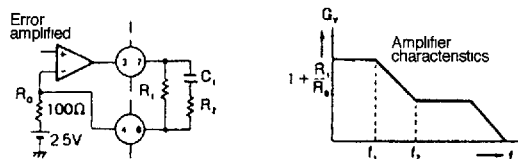

## Error amplifier

The motor system error amplifier DC gain is set internally as follows:

$$G_{OM1} \cong 14\text{ dB}, G_{OM2} \cong 10\text{ dB}, G_{OM3} = G_{OM4} \cong 10\text{ dB},$$

For the M3 and M4 systems, the input/output phase characteristics run in reverse.

# BA6149LS Voltage regulator—switching

## Figure 1 Test circuit

