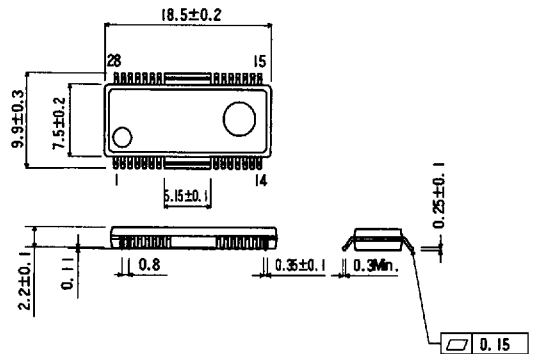

The BA6396FP is a 4-channel BTL driver for the motors or actuators on a CD player.

Dimensions (Units : mm)**BA6396FP (HSOP28)****Features**

- available in a HSOP28 package
- supply voltage range (6 ~ 9V)
- gain of driver output can be changed by changing a single external resistor
- includes general purpose operational amplifier
- internal 5 V regulator
- built-in thermal shutdown circuit
- internal mute circuit provided. Channel 1 can be muted by changing logic input, mute on when bias pin HIGH
- built-in thermal shutdown circuit

**Applications**

- CD player
- CD-ROM

Block diagram

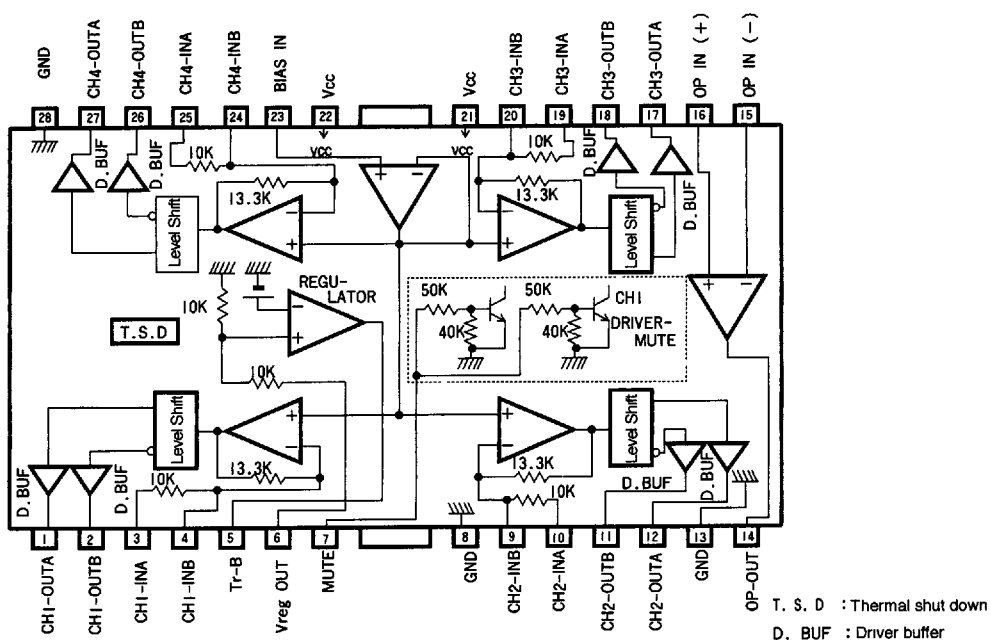

Table 1 Pin description (Sheet 1 of 2)

Pin no.	Symbol	Description
1	CH1OUT A	Driver CH1 negative output
2	CH1OUT B	Driver CH1 positive output
3	CH1 IN A	Driver CH1 input
4	CH1 IN B	Driver CH1 input, gain adjustment pin
5	Tr B	Connect to external transistor base
6	V _{REG} OUT	Constant voltage output, connects to external transistor collector
7	MUTE	Driver mute control input
8	GND	Ground
9	CH2 IN B	Driver CH2 input, gain adjustment pin
10	CH2 IN A	Driver CH2 input
11	CH2OUT B	Driver CH2 positive output
12	CH2OUT A	Driver CH2 negative output
13	GND	Substrate ground
14	OP OUT	Operational amplifier output

Table 1 Pin description (Sheet 2 of 2)

Pin no.	Symbol	Description
15	OP IN(-)	Operational amplifier input, negative
16	OP IN(+)	Operational amplifier input, positive
17	CH3OUT A	Driver CH3 negative output
18	CH3OUT B	Driver CH3 positive output
19	CH3 IN A	Driver CH3 input
20	CH3 IN B	Driver CH3 input, gain adjustment pin
21	V _{CC}	
22	V _{CC}	
23	BIAS IN	Bias amplifier input
24	CH4 IN B	Driver CH4 input, gain adjustment pin
25	CH4 IN A	Driver CH4 input
26	CH4OUT B	Driver CH4 positive output
27	CH4OUT A	Driver CH4 negative output
28	GND	Substrate ground

Absolute maximum ratings (T_a = 25°C)

Parameter	Symbol	Limits	Unit	Conditions
Power supply voltage	V _{CC}	18	V	
Power dissipation	P _d	1.7	W	Reduce power by 13.6 mW for each degree above 25°C. Mounted on 50 × 50 × 1.0 mm phenol paper PCB.
Operating temperature	T _{opr}	-35 ~ +85	°C	
Storage temperature	T _{stg}	-55 ~ +150	°C	

Recommended operating conditions (T_a = 25°C)

Parameter	Symbol	Min	Typical	Max	Unit	Conditions
Power supply voltage	V _{CC}	6	8	9	V	Driver section can operate as low as 5.5 V

Electrical characteristics (unless otherwise noted, $T_a = 25^\circ\text{C}$, $V_{CC} = 8\text{ V}$, $R_L = 8\ \Omega$, $f = 1\text{ kHz}$)

Parameter	Symbol	Min	Typical	Max	Unit	Conditions
Quiescent current	I_{CC}	6.0	10.0	14.0	mA	No load
Output voltage, offset	V_{OO}	-40		40	mV	
Output voltage, HIGH	V_{OHD}	5.2	5.6		V	
Output voltage, LOW	V_{OLD}		1.3	1.55	V	
Gain (close circuit)	G_{VC}	7.0	8.0	9.0	dB	$V_{IN} = 0.1\text{ V}_{rms}$
Ripple rejection	RR		60		dB	$V_{IN} = 0.1\text{ m V}_{rms}$, $f = 100\text{ Hz}$
Slew rate	SR		2.0		V/ μs	$V_{OUT} = 0.3\text{ V}_{pk-pk}$, square wave, $f = 100\text{ kHz}$
Mute-on voltage	V_{MON}	2.2			V	
Mute-off voltage	V_{MOFF}			0.4	V	
5 V regulator						
Output voltage	V_{REG}	4.75	5.00	5.25	V	$I_L = 100\text{ mA}$
Output load variation	ΔV_{RL}	-50	0	10	mV	$I_L = 0 \sim 200\text{ mA}$
Power supply voltage variation	ΔV_{VCC}	-10	0	25	mV	$I_L = 100\text{ mA}$, ($V_{CC} = 6 \sim 9\text{ V}$)
Operational amplifier						
Offset voltage	V_{OFOP}	-5	0	5	mV	
Input bias current	I_{BOP}			300	nA	
High-level output voltage	V_{OHOP}	6.0			V	
Low-level output voltage	V_{OLOP}			1.8	V	
Output drive current (sink)	I_{SINK}	10	50		mA	$50\ \Omega$ at V_{CC}
Output drive current (source)	I_{SOURCE}	10	40		mA	$50\ \Omega$ at ground
Voltage gain (open circuit)	G_{VO}		78		dB	$V_{IN} = -75\text{ dBV}$
Slew rate	SR_{OP}		1		V/ μs	100 kHz square wave, $V_{OUT} = 4\text{ V}_{pk-pk}$
Ripple rejection	RR_{OP}		65		dB	$V_{IN} = -20\text{ dBV}$, $f = 100\text{ Hz}$
Common mode rejection ratio	CMRR	70	84		dB	$V_{IN} = -20\text{ dBV}$

Figure 1 Application example

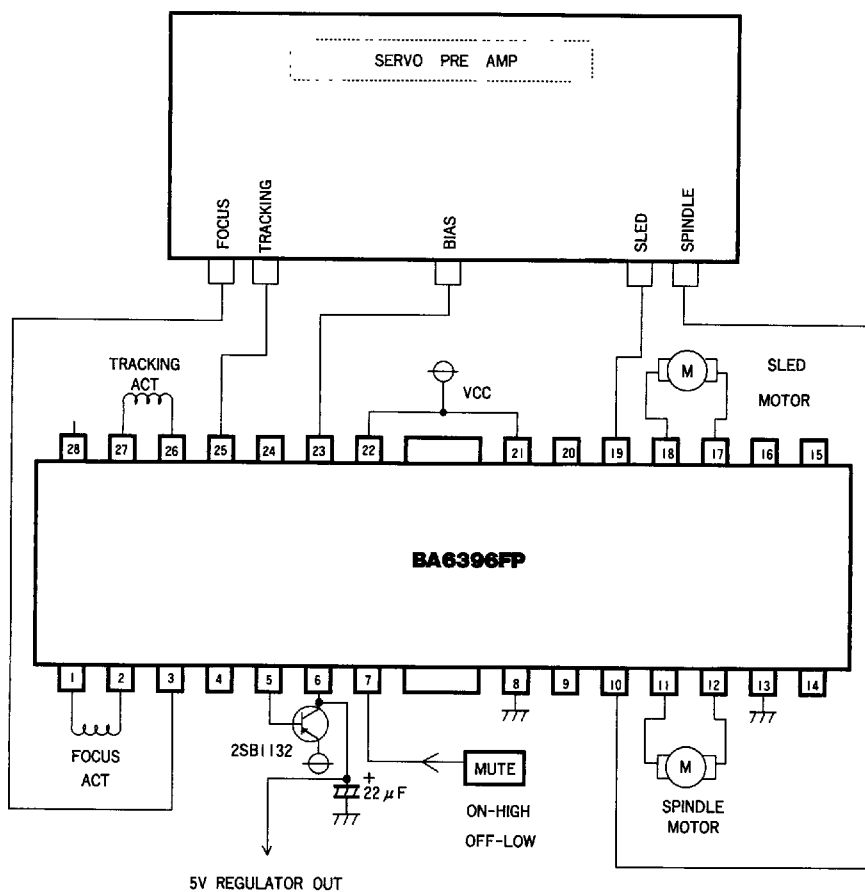
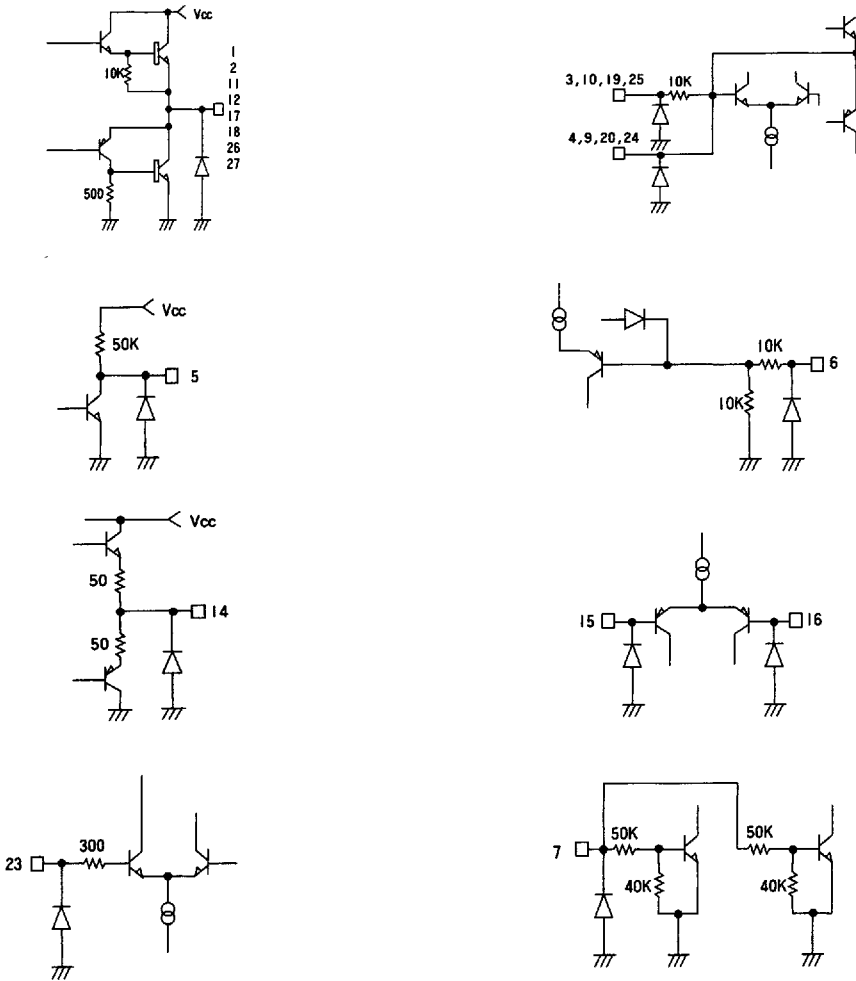

Figure 2 Input and output equivalent circuits



Circuit operation

Drivers

The error signal of the focus tracking from the servo pre-amplifier and the control signal from the motor are the input to the driver.

The input is normally a signal centered around 2.5 V. This voltage is converted to a current by the pre-stage amplifier. (See Figure 3.) The current flows through the internal reference voltage section by way of the resistor. As a result, the output of the pre-stage amplifier is a signal centered on the internal reference voltage.

Note that when performing the voltage to current conversion, a positive phase and a negative phase are created. The BTL output is acquired through the drive buffer.

Figure 3 Driver equivalent circuit

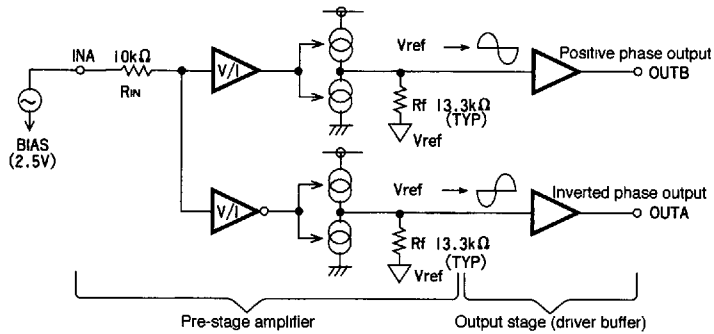

Voltage regulator

The voltage regulator is a typical series regulator which creates a reference voltage internally. A PNP low -saturated- type transistor is connected externally.

Figure 4 Voltage regulator equivalent circuit

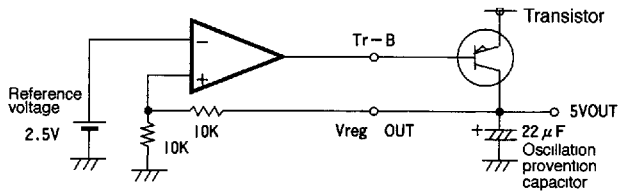

Operational amplifier

This is a standard 4558 type.

Precautions for use

- A thermal shut down circuit is built into the BA6396FP. When the temperature of the chip reaches 175°C (typically), the output current is muted.
- If the mute pin (pin 7) voltage rises above 2.2 V, the output current of CH1 (between pin 1 and pin 2) will be muted. Under normal operating conditions, make sure to open pin 7 or pull it down below 0.4 V.
- If the bias pin (pin 23) drops below 1.4 V, the output is muted. Make sure that under normal operating conditions, this pin is at 1.6 V or above.
- If the power supply voltage drops below 4.5 V, the drivers are turned OFF. When the voltage exceeds 4.7 V, the drivers return to their previous state.

- The channel 4 output is muted in the event of a thermal shut down, a mute on, a bias pin voltage drop, or a power supply voltage drop. Other sections are not muted.
- When muted, the internal bias voltage of the output pin becomes roughly $(V_{CC} - V_F)/2$.
- The built-in input resistance has a positive temperature coefficient of 2000 ppm/°C. When changing the gain using an external resistance, the gain will change as the temperature of the resistor changes. When using the built-in input resistance, there are virtually no gain variations due to temperature.
- Make sure to connect a 0.1 mF capacitor to the dc supplied power main input to filter out voltage ripples.
- Heat dissipation fins are attached to the GND on the inside of the package. Make sure to connect these to the external GND.
- The capacitor connected between the regulator output (pin 6) and the GND also serves to stop oscillation of the IC circuit. Consequently, make sure to use one with good temperature characteristics.

Electrical characteristic curves

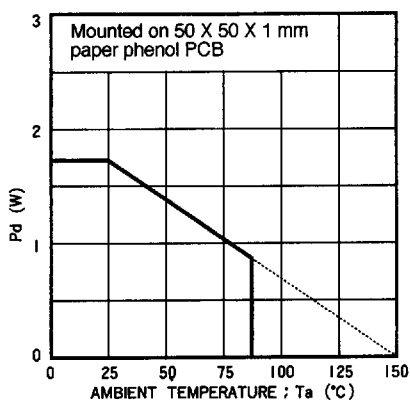

Figure 5

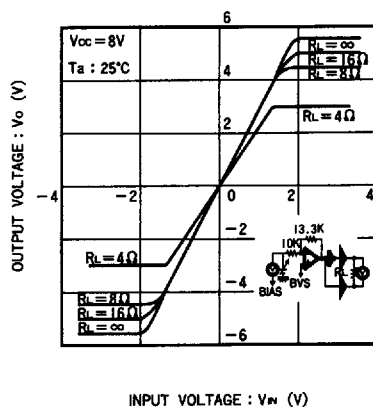

Figure 6

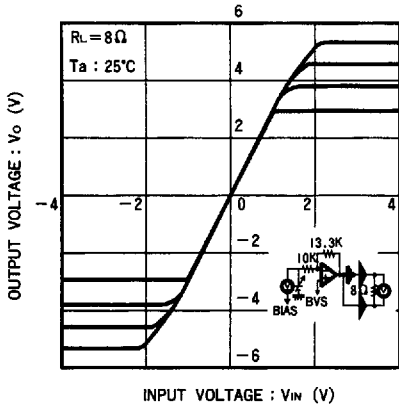

Figure 7

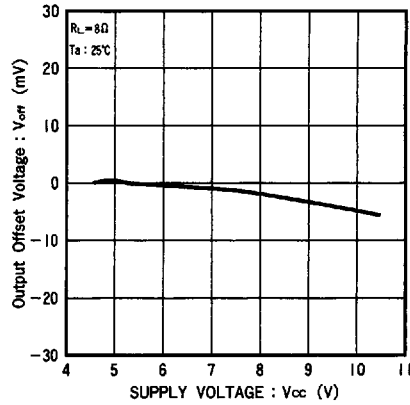

Figure 8

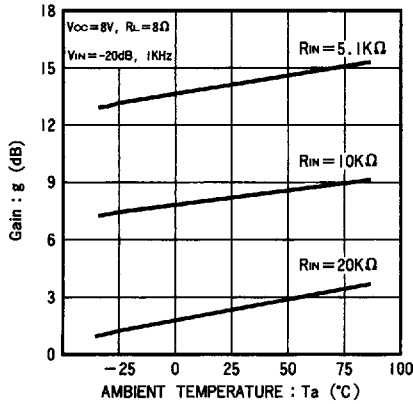

Figure 9

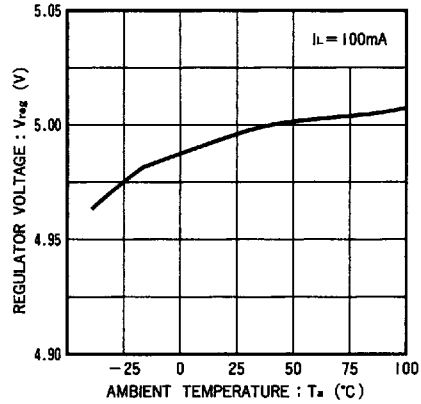

Figure 10

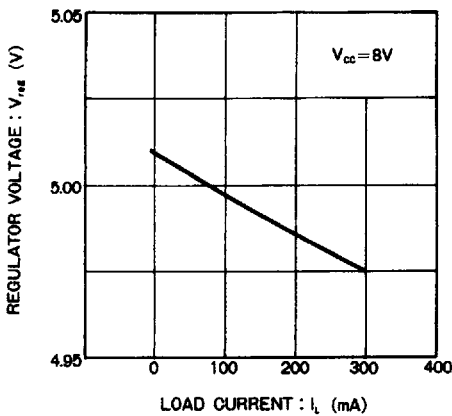

Figure 11

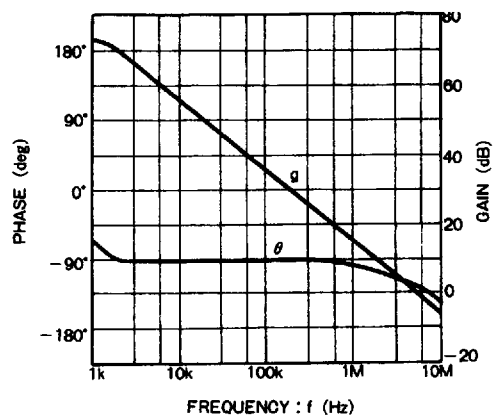

Figure 12