

# 2-phase motor driver for VCR cylinder motors

## BA6827FS

The BA6827FS is a direct-drive motor driver suitable for 2-phase, full-wave linear motors. It contains Hall amplifier control circuits, drivers, FG and PG signal amplifiers, and hysteresis amplifiers.

●Applications  
VCR cylinder motors

●Features

- 1) Linear drive system provides low switching noise.
- 2) Output current can be controlled with current input and voltage input pins.
- 3) Two amplifiers and two hysteresis amplifiers are built in.
- 4) Constant voltage pin for Hall device power supply.
- 5) High ratio of output current over control current. (4000 typically)
- 6) Available in a compact surface-mount package.

●Block diagram

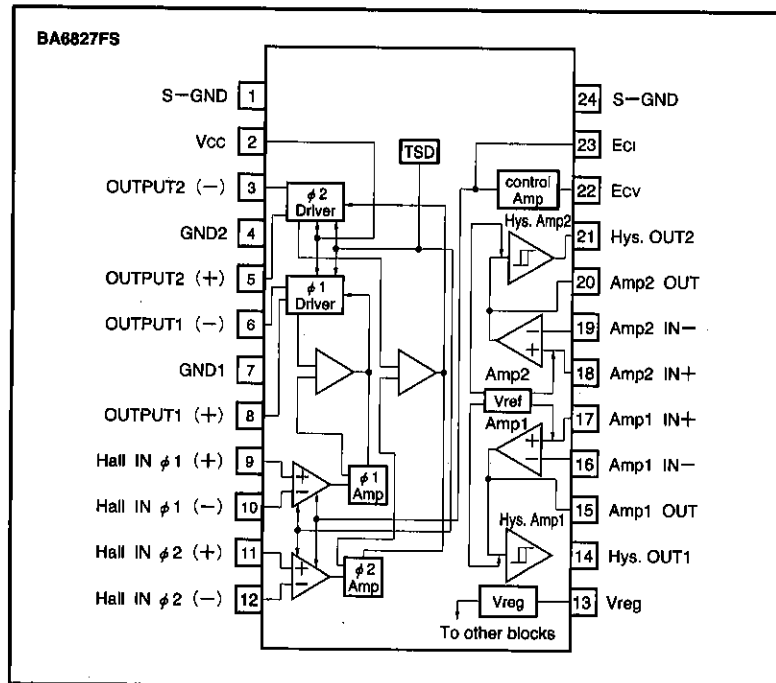

## ● Absolute maximum ratings (Ta=25°C)

Parameter	Symbol	Limits	Unit
Power supply voltage	V <sub>CC</sub>	24	V
Power dissipation	P <sub>d</sub>	1000*1	mW
Operating temperature	T <sub>opr</sub>	-25~75	°C
Storage temperature	T <sub>stg</sub>	-55~150	°C
Output current	I <sub>OMax</sub>	1200*2	mA
Input current	I <sub>CI</sub> Max	5	mA

\*1 Mounted on a glass epoxy PCB (90 X 50 X 1.6 mm).

Reduce power by 8 mW for each degree above 25°C.

\*2 Should not exceed P<sub>d</sub>- or ASO-value (for the current of one phase).

## ● Recommended operating conditions

Parameter	Symbol	Limits	Unit
Operating power supply voltage	V <sub>CC</sub>	8.0~20.0	V

● Electrical characteristics (Unless otherwise noted, Ta=25°C, V<sub>CC</sub>=12V)

Parameter	Symbol	Min.	Typ.	Max.	Unit	Conditions
Circuit current	I <sub>CC</sub>	—	8.5	13.0	mA	
Constant output voltage	V <sub>reg</sub>	4.6	5.0	5.4	V	
~MDA~						
Hall device minimum input level	V <sub>INH</sub>	50	—	—	mV <sub>P-P</sub>	
Hall device input bias current	I <sub>BH</sub>	—	0.25	2.0	μA	I <sub>cont</sub> =100 μA
HIGH level output saturation voltage	V <sub>OH</sub>	10.45	10.79	—	V	I <sub>out</sub> =800mA
LOW level output saturation voltage	V <sub>OL</sub>	—	1.33	2.16	V	I <sub>out</sub> =800mA
~ECV (voltage regulation) ~						
Torque control input voltage	E <sub>CV</sub>	0	—	V <sub>reg</sub>	V	
Torque control voltage offset	E <sub>CV</sub> OFFS	-150	0	150	mV	For 0.48 X V <sub>reg</sub>
Torque control input current	I <sub>ECVIN</sub>	—	1.0	6	μA	E <sub>CV</sub> =2.5V
Output idle current	I <sub>ECVidle</sub>	—	0	5	mA	E <sub>CV</sub> =2.0V
I/O gain	G <sub>ECV</sub>	0.42	0.55	0.68	A/V	Measured at E <sub>CV</sub> = 2.8 V, 3.3 V; ΔV <sub>IN</sub> = 100 mV
~ECI (current control) ~						
Ratio of pin-23 current and output current	I <sub>OUT</sub> / I <sub>cont</sub>	3000	4000	5000	—	ΔV <sub>IN</sub> = 100 mV; measured at I <sub>cont</sub> = 30 μA, 50 μA
Output current differential	ΔI <sub>out</sub>	-30	0	+30	mA	I <sub>cont</sub> = 30 μA
~Amp1, Amp2~						
-Input current	I <sub>INA</sub>	—	0.2	2.0	μA	V <sub>IN</sub> = 2.5V
Open loop gain	G <sub>A</sub>	65	70	—	dB	f <sub>IN</sub> = 500Hz
DC bias voltage variation	ΔV <sub>BA</sub>	-10	0	10	%	Variation from 1/2 V <sub>reg</sub>
HIGH level output voltage	V <sub>OH</sub> A	V <sub>reg</sub> -1.48	V <sub>reg</sub> -1.08	—	V	I <sub>OH</sub> A = 0.5mA
LOW level output voltage	V <sub>OL</sub> A	—	1.05	1.45	V	I <sub>OL</sub> A = 0.5mA
Input voltage of amplifiers 1 and 2	V <sub>AB</sub>	1.2	—	4.0	V	
~Hys. Amp1, 2~						
Hysteresis width	V <sub>hys</sub>	±142	±180	±218	mV	
LOW level output voltage	V <sub>OL</sub> hys	—	0.12	0.32	V	I <sub>OL</sub> hysA = 2mA
Output pull-up resistance	V <sub>thys</sub>	7.0	10.0	13.0	kΩ	

©Not designed for radiation resistance

## ● Pin description

Pin No.	Pin name	Function
1	S-GND	Signal ground pin
2	V <sub>CC</sub>	Power supply pin
3	OUTPUT2(-)	Output pin
4	GND2	OUTPUT2 GND
5	OUTPUT2(+)	Output pin
6	OUTPUT1(-)	Output pin
7	GND1	OUTPUT1 GND
8	OUTPUT1(+)	Output pin
9	Hall IN $\phi_1$ (+)	Hall signal input pin
10	Hall IN $\phi_1$ (-)	Hall signal input pin
11	Hall IN $\phi_2$ (+)	Hall signal input pin
12	Hall IN $\phi_2$ (-)	Hall signal input pin
13	V <sub>reg</sub>	Constant voltage output pin
14	Hys.out <sub>1</sub>	Hysteresis amplifier 1 output pin
15	Amp1 <sub>out</sub>	Amplifier 1 output pin; hysteresis amplifier 1 input pin
16	Amp1 <sub>in-</sub>	Amplifier 1 Input pin, inverted
17	Amp1 <sub>in+</sub>	Amplifier 1 Input pin, non-inverted
18	Amp2 <sub>in+</sub>	Amplifier 2 Input pin, non-inverted
19	Amp2 <sub>in-</sub>	Amplifier 2 Input pin, inverted
20	Amp2 <sub>out</sub>	Amplifier 2 output pin; hysteresis amplifier 2 input pin
21	Hys.out <sub>2</sub>	Hysteresis amplifier 2 output pin
22	E <sub>cv</sub>	Output current control pin (voltage control)
23	E <sub>ci</sub>	Output current control pin (current control)
24	S-GND	Signal ground pin

www.DataSheet4U.com

● Input/output circuits

(1)  $E_{cv}$  (22 pin)

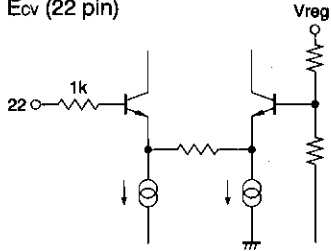

(Resistances, in  $\Omega$ , are typical values)

Fig.1

(2) Driver output (8, 6, 5, 3 pin)

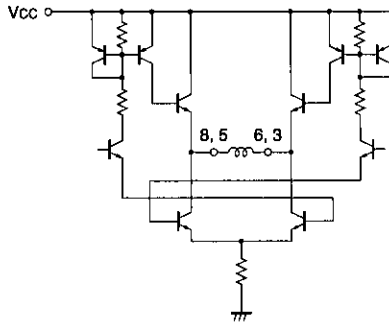

(Resistances, in  $\Omega$ , are typical values)

Fig.2

(3) Hall input (9, 10, 11, 12 pin) and  $E_{ci}$  input

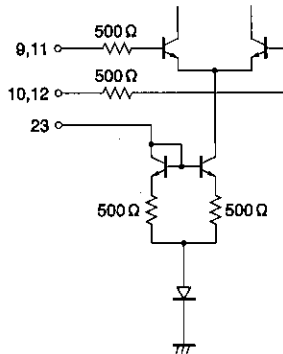

(Resistances, in  $\Omega$ , are typical values)

Fig.3

(4) I/O of amplifiers 1 and 2

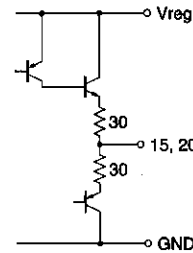
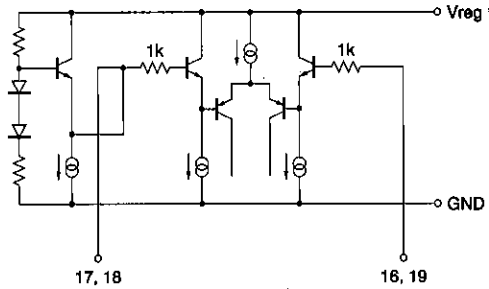

(Resistances, in  $\Omega$ , are typical values)

Fig.4

(5) I/O of hysteresis amplifier

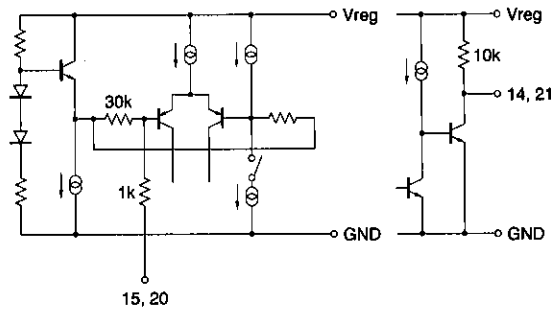

(Resistances, in  $\Omega$ , are typical values)

Fig.5

\* Note that resistance values of the I/O circuits can vary  $\pm 30\%$ .

● Circuit operation

(1) The signal from the Hall device is amplified by the Hall amplifier and then supplied to the driver circuit. The driver gain, which is constant, is regulated by changing the Hall amplifier gain with the  $E_{ci}$  input current or the  $E_{cv}$  input voltage ( $E_{ci}$  and  $E_{cv}$  are output current control pins). The motor rotational speed is sensed by the FG, and the output from which is F/V-converted and supplied to the  $E_{ci}$  pin or F/V-converted and supplied to the  $E_{cv}$  pin as a feedback signal, so that a constant rotational speed is maintained as follows (Fig. 6) :

- 1) The motor speed decreases.
- 2) The speed control IC outputs a feedback signal.
- 3) The Hall amplifier gain increases.
- 4) The output current increases.
- 5) The motor speed increases.

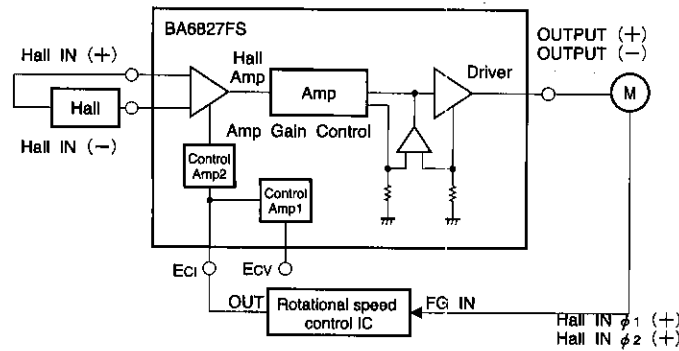

Fig.6

(2) When the voltage on Hall IN  $\phi_1$  (+) is higher than the voltage on Hall IN  $\phi_1$  (-), an output current flows from OUT1 (+) to OUT1 (-). When the voltage on Hall IN  $\phi_1$  (-) is higher, on the other hand, an output current flows from OUT1 (-) to OUT1 (+).

Similarly, when the voltage on Hall IN  $\phi_2$  (+) is higher than the voltage on Hall IN  $\phi_2$  (-), an output current flows from OUT2 (+) to OUT2 (-). When the voltage on Hall IN  $\phi_2$  (-) is higher, on the other hand, an output current flows from OUT2 (-) to OUT2 (+).

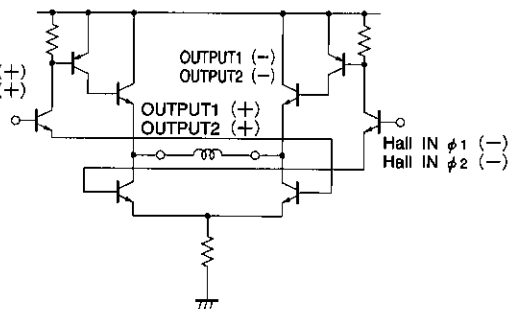

Fig.7

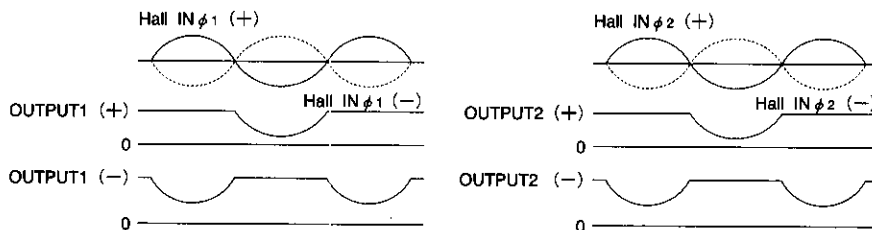

Fig.8

(3) Output waveforms are shown in Fig. 9. Because of the amplifier offset, the output is left OPEN when the output signal switches from positive to negative. The output waveform is determined by the external circuit because the IC impedance increases during this transition period. Since inductive loads are usually provided, a capacitor should be connected to suppress the backlash voltage.

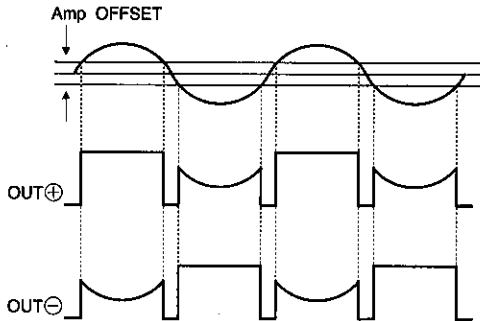

Fig.9

● Operation notes

1. Ecv input (22 pin)

The Ecv input is plotted against the output current in Fig. 10.

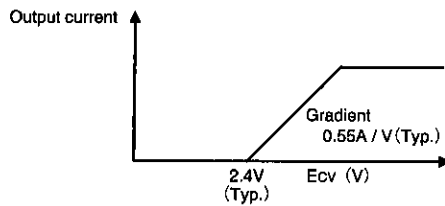

Fig.10

2. Hall input

Hall input signals of 50mV (peak to peak) or greater should be applied between pins 9 and 10 and between pins 11 and 12. The DC input range is 2V to (Vreg - 1.5V). There will be no problem if the input is centered around Vreg/2.

Because the Hall input impedance is 1MΩ or greater, any type of Hall device can be connected. No current flows when the transistor is off because pins 9 and 10 as well as pins 11 and 12 are differential inputs.

Because the IC is a linear driver, any DC offset in the Hall device will be amplified and appear in the output. Use Hall devices having a minimum offset. Hall devices can be connected in either series or parallel.

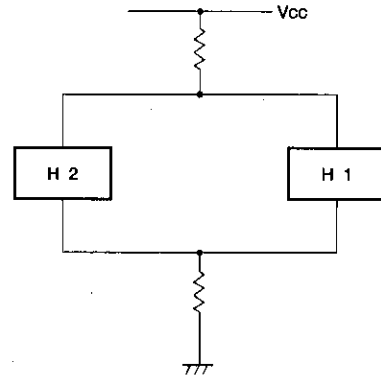

Parallel connection

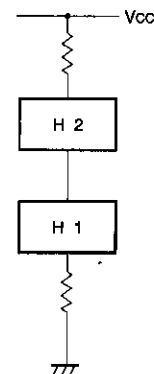

Series connection

Fig.11

● Operation notes

3.  $E_{ci}$  input

The  $E_{ci}$  input circuit has  $2V_F$  and a  $500\ \Omega$  resistor connected in series. Current is limited only by the  $500\ \Omega$  resistor.

4. Amplifiers 1 and 2

An input range of  $0.6V$  to  $(V_{CC} - 1.2V)$  is recommended. Unpredictable outputs may occur when the input is outside this range.

5. Hysteresis amplifier

An input range of  $0.6V$  to  $(V_{CC} - 1.2V)$  is recommended. Unpredictable outputs may occur when the input is outside this range.

6. Thermal shutdown circuit

The circuit puts the driver outputs (pins 3, 5, 6, and 8) to the open state at the temperature of  $175^\circ C$  (typical). There is a temperature difference of about  $20^\circ C$  between the temperatures at which the circuit is activated and deactivated.

7. Signal ground pin

Pins 1 and 24 are signal ground pins. Be noted that unpredictable outputs may occur if your application causes a large current between pins 1 and 24 through the bonding wire chip.

● Application example

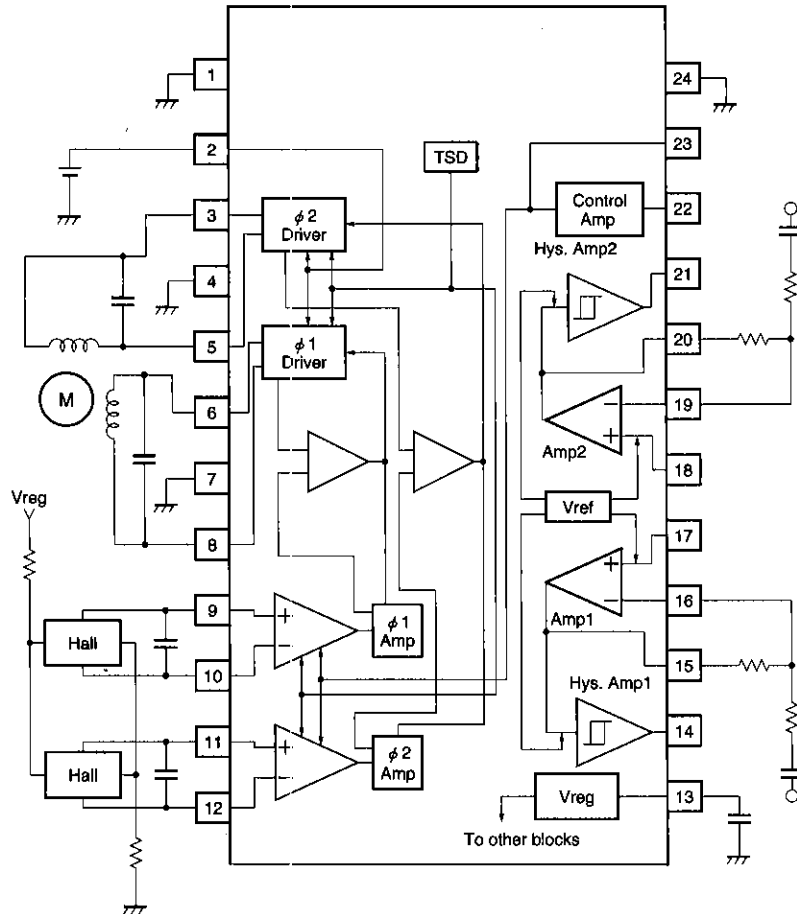

Fig.12

www.DataSheet4U.com

● Electrical characteristic curves

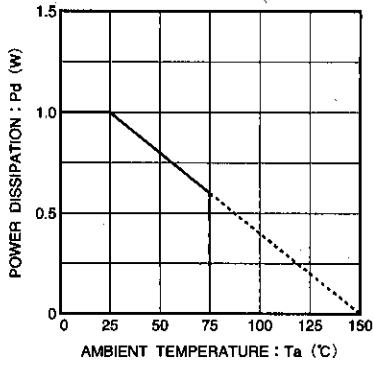

Fig.13 Temperature dependence of power dissipation curve

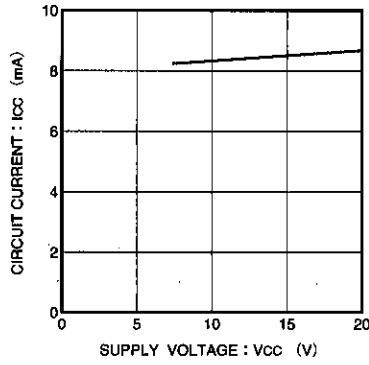

Fig.14 Circuit current vs. supply voltage

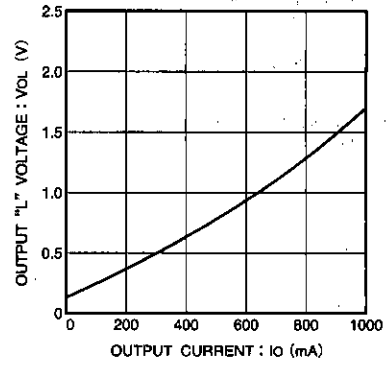

Fig.15 LOW level output voltage vs. output current

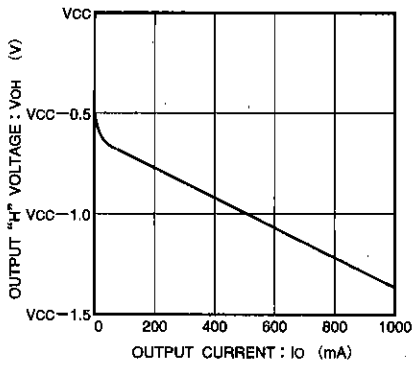
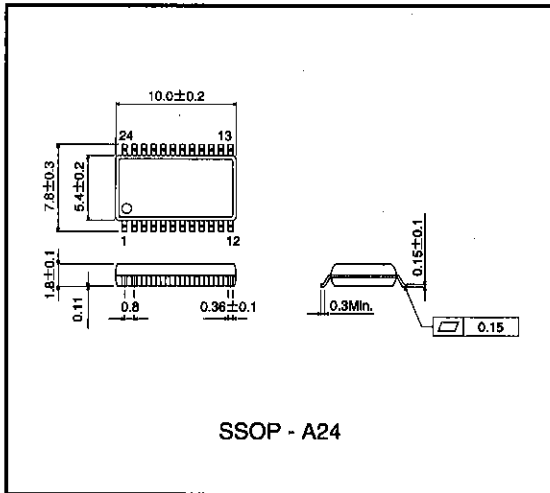

Fig.16 HIGH level output voltage vs. output current

● External dimensions (Units: mm)



Two-Phase Full-Wave Motor Drivers for Cylinder Motors

Motor Drivers for VCRs