

Small Signal Schottky diode

BAR40S2

Features

- Guard ring protected
- Low forward voltage drop
- Very small plastic SMD package
- Pb-free lead plating and halogen-free package

Applications

- Ultra high-speed switching
- Voltage clamping
- Protection circuits
- Blocking diodes

Symbol

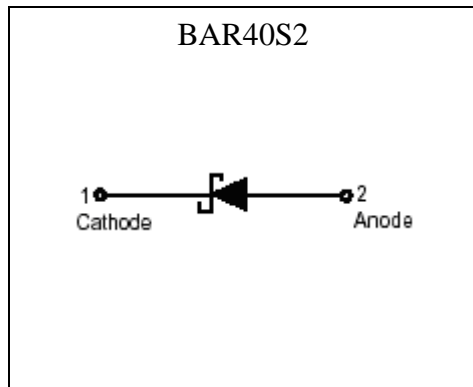

Outline

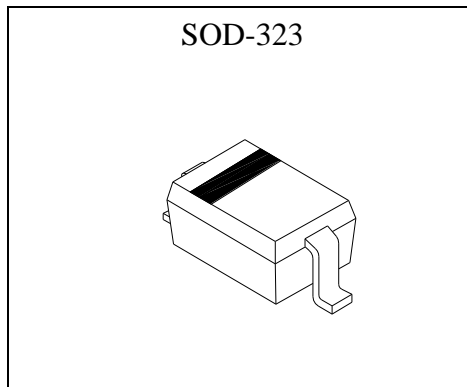

Ordering Information

Device	Package	Shipping
BAR40S2-0-T1-G	SOD-323 (Pb-free lead plating and halogen-free package)	3000 pcs / tape & reel

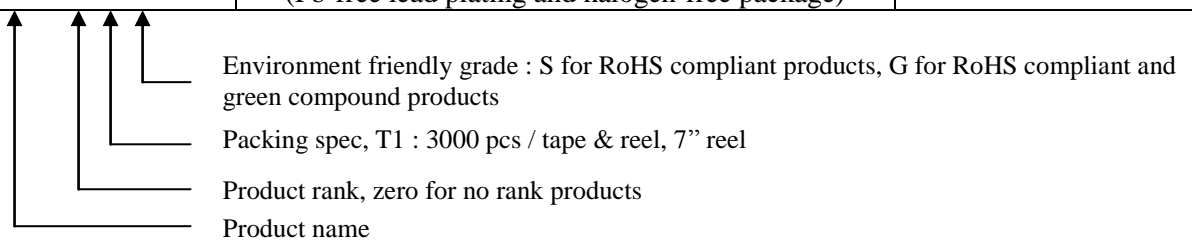



Absolute Maximum Ratings

Symbol	Parameter	Conditions	Min	Max	Unit
V _R	continuous reverse voltage		-	40	V
I _F	continuous forward current		-	200	mA
I _{FRM}	repetitive peak forward current	tp≤1s, δ≤0.5	-	300	mA
I _{FSM}	non-repetitive peak forward current	tp<1ms	-	1000	mA
P _{tot}	total power dissipation	T _{amb} ≤25°C	-	200	mW
T _{stg}	storage temperature		-65	+150	°C
T _j	operating junction temperature		-65	+150	°C
T _{amb}	operating ambient temperature		-65	+125	°C

Characteristics (Ta=25°C, unless otherwise specified)

Parameter	Symbol	Condition	Min.	Max.	Unit
Reverse Breakdown Voltage	V _{BR}	I _R =100μA	40	-	V
Forward Voltage (Note 1)	V _F (1)	I _F =0.1mA	-	240	mV
	V _F (2)	I _F =1mA	-	320	mV
	V _F (3)	I _F =10mA	-	400	mV
	V _F (4)	I _F =30mA	-	500	mV
	V _F (5)	I _F =100mA	-	800	mV
Reverse Leakage Current (Note 2)	I _R	V _R =25V	-	2	μA
Diode Capacitance	C _D	V _R =1V, f=1MHz	-	10	pF
Reverse Recovery Time	trr	when switched from I _F = 10mA to I _R =10mA; R _L =100Ω; measured at I _R =1mA	-	5	ns

Notes: 1.pulse test, tp=380μs, duty cycle<2%.
2.pulse test, tp=300μs, duty cycle<2%.

Thermal Characteristics

Symbol	Parameter	Conditions	Value	Unit
R _{th j-a}	thermal resistance from junction to ambient	note 1	635	K/W

Note 1 : Device mounted on a FR-4 PCB

Typical Characteristics

Forward Current vs Forward Voltage

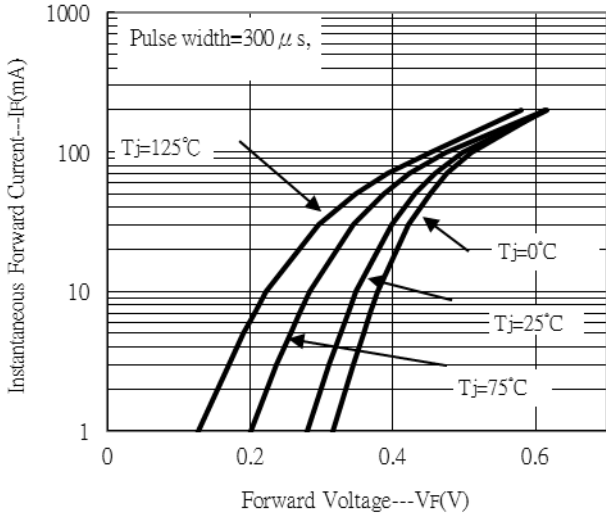

Reverse Leakage Current vs Reverse Voltage

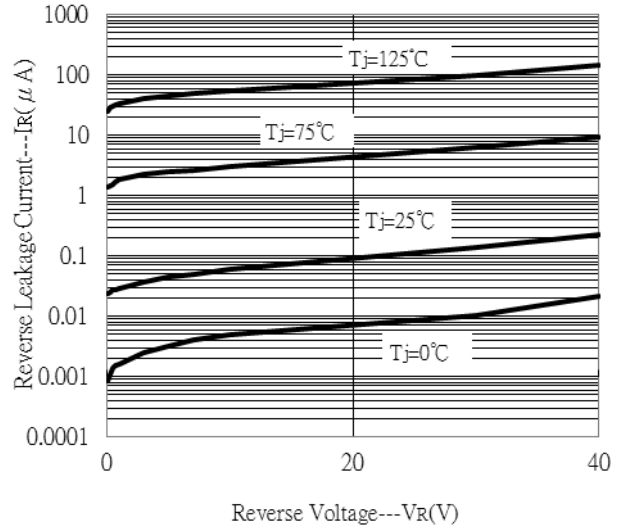

Junction Capacitance vs Reverse Voltage

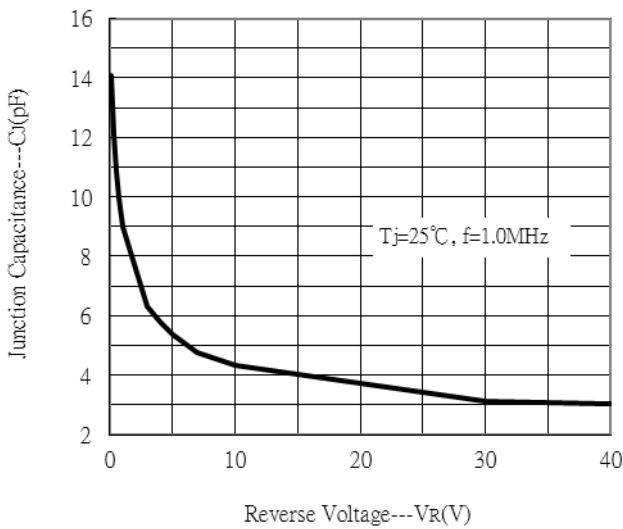

Recommended Footprint

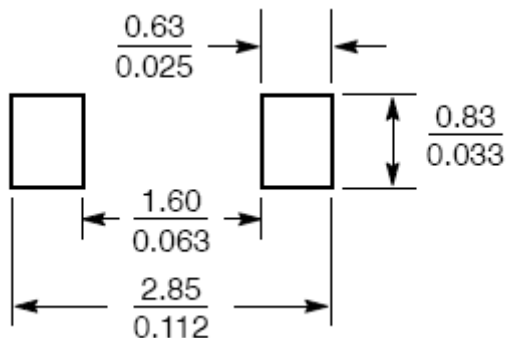

mm
 inch

Reel Dimension

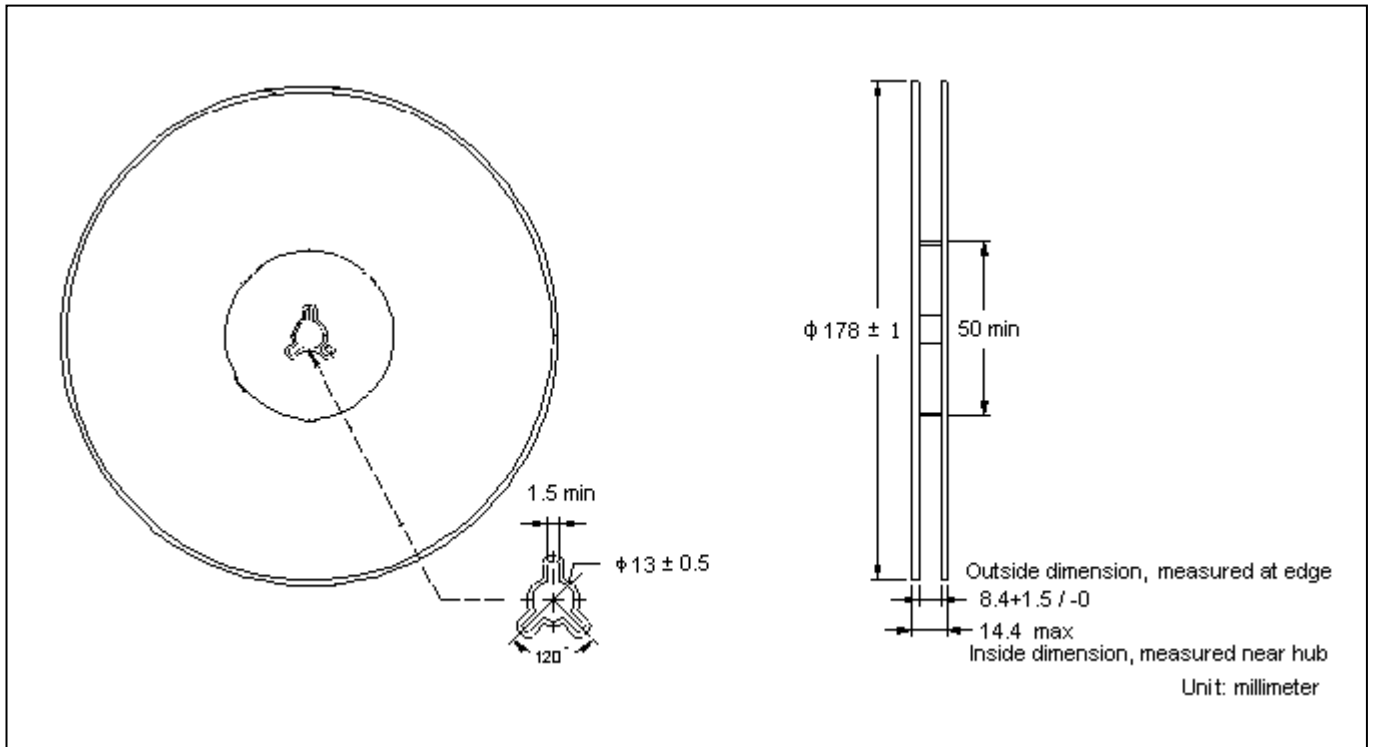

Carrier Tape Dimension

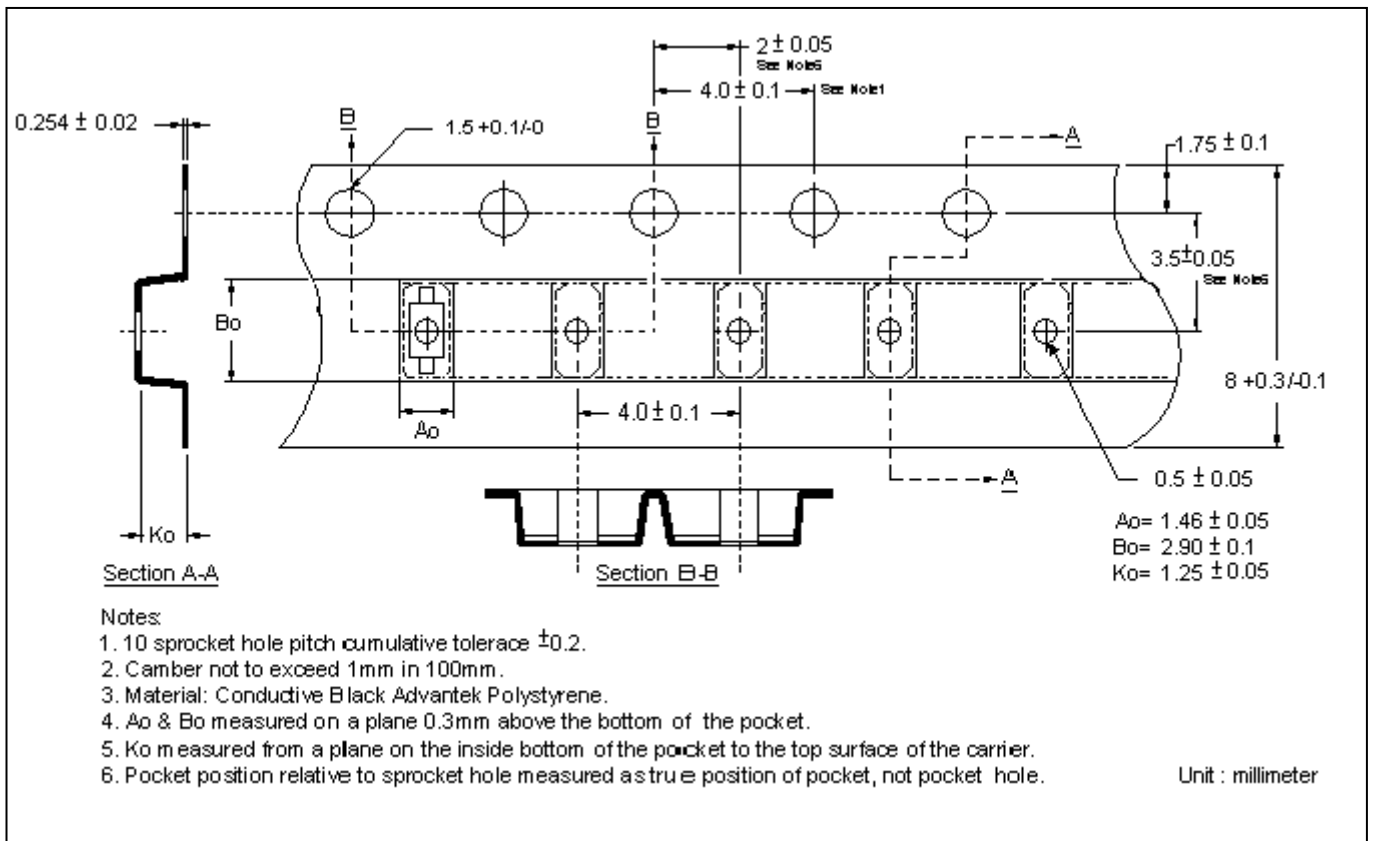

Notes:

1. 10 sprocket hole pitch cumulative tolerance ± 0.2 .
2. Camber not to exceed 1mm in 100mm.
3. Material: Conductive Black Advantek Polystyrene.
4. A_0 & B_0 measured on a plane 0.3mm above the bottom of the pocket.
5. K_0 measured from a plane on the inside bottom of the pocket to the top surface of the carrier.
6. Pocket position relative to sprocket hole measured as true position of pocket, not pocket hole.

Recommended wave soldering condition

Product	Peak Temperature	Soldering Time
Pb-free devices	260 +0/-5 °C	5 +1/-1 seconds

Recommended temperature profile for IR reflow

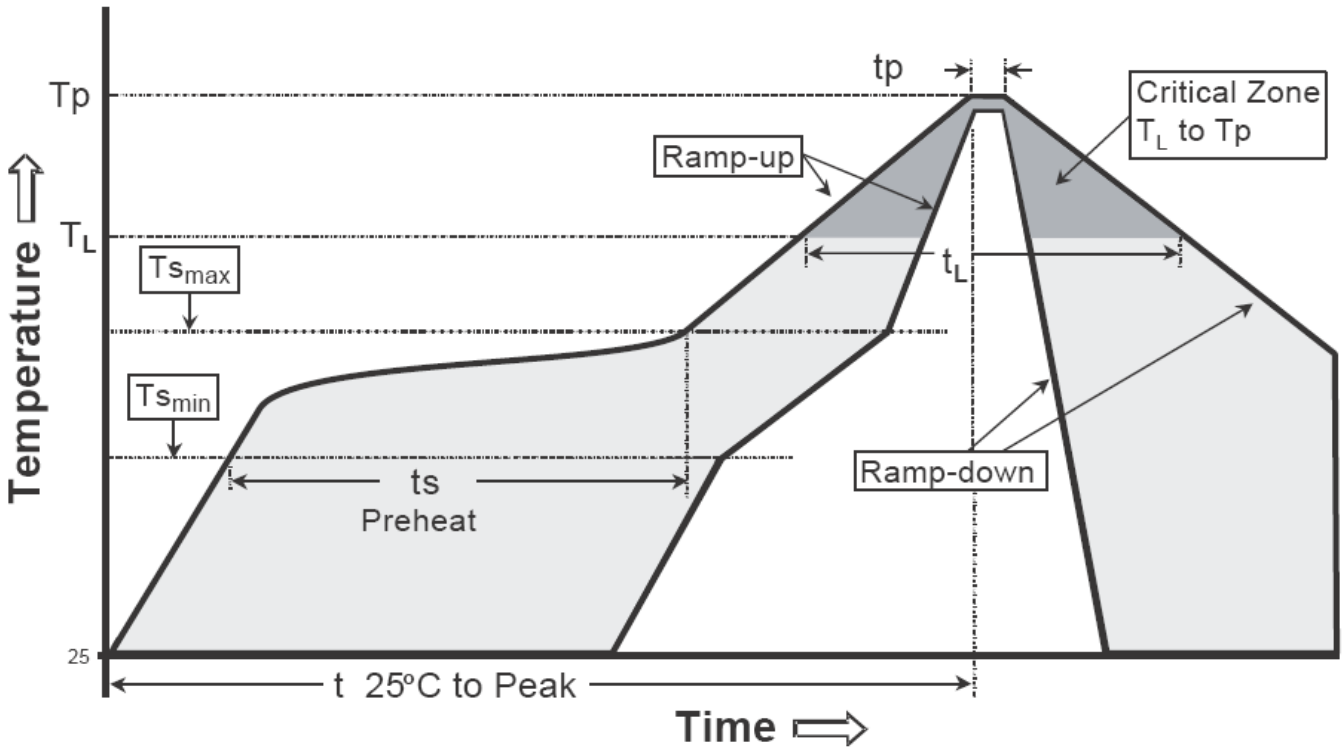

Profile feature	Sn-Pb eutectic Assembly	Pb-free Assembly
Average ramp-up rate (Tsmax to Tp)	3°C/second max.	3°C/second max.
Preheat		
-Temperature Min(Ts min)	100°C	150°C
-Temperature Max(Ts max)	150°C	200°C
-Time(ts min to ts max)	60-120 seconds	60-180 seconds
Time maintained above:		
-Temperature (TL)	183°C	217°C
- Time (tL)	60-150 seconds	60-150 seconds
Peak Temperature(Tp)	240 +0/-5 °C	260 +0/-5 °C
Time within 5°C of actual peak temperature(tp)	10-30 seconds	20-40 seconds
Ramp down rate	6°C/second max.	6°C/second max.
Time 25 °C to peak temperature	6 minutes max.	8 minutes max.

Note : All temperatures refer to topside of the package, measured on the package body surface.

SOD-323 Dimension

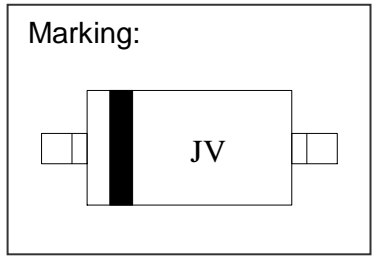
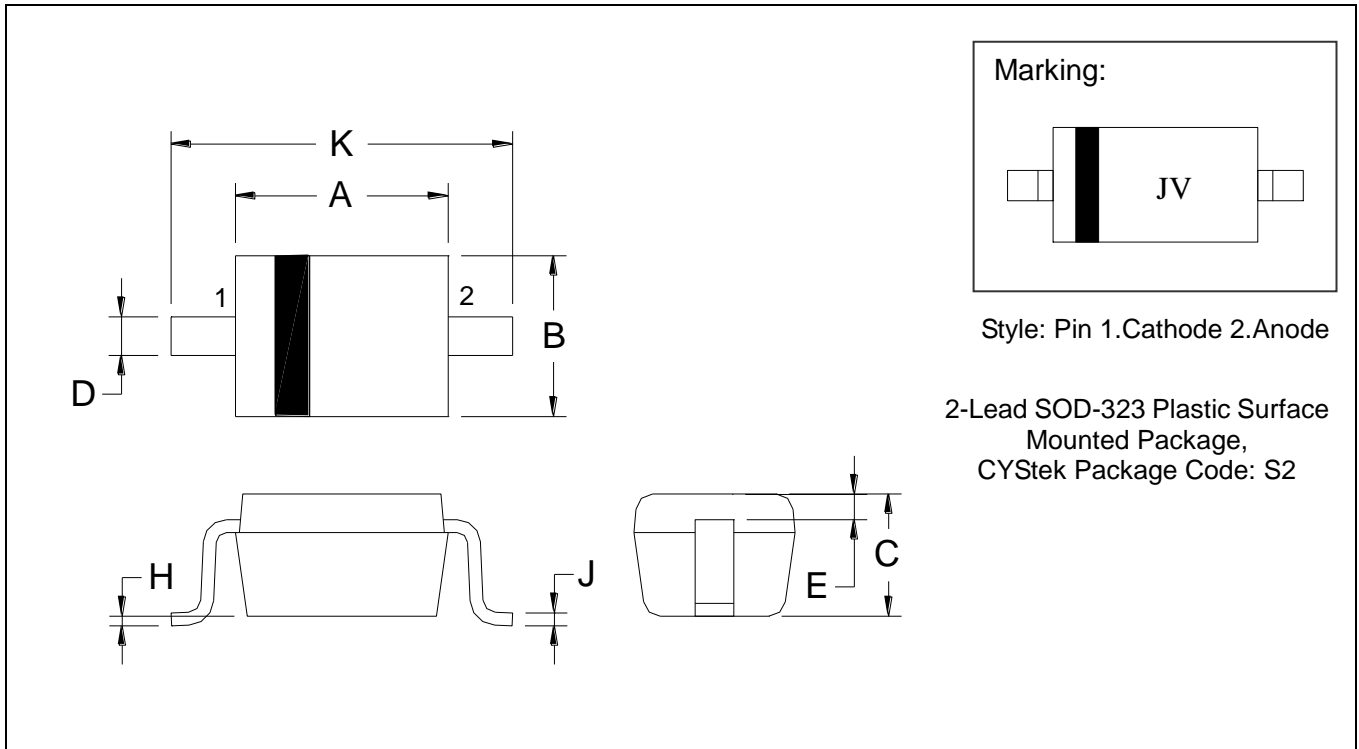

Style: Pin 1.Cathode 2.Anode

2-Lead SOD-323 Plastic Surface Mounted Package, CYStek Package Code: S2

*: Typical

DIM	Inches		Millimeters		DIM	Inches		Millimeters	
	Min.	Max.	Min.	Max.		Min.	Max.	Min.	Max.
A	0.0630	0.0709	1.60	1.80	E	0.0060 REF		0.15 REF	
B	0.0453	0.0531	1.15	1.35	H	0.0000	0.0040	0.00	0.10
C	0.0315	0.0394	0.80	1.00	J	0.0035	0.0070	0.089	0.177
D	0.0098	0.0157	0.25	0.40	K	0.0906	0.1063	2.30	2.70

- Notes: 1.Controlling dimension : millimeters.
 2.Lead thickness specified per L/F drawing with solder plating.
 3.If there is any question with packing specification or packing method, please contact your local CYStek sales office.

Material:

- Lead: Pure tin plated.
- Mold Compound: Epoxy resin family, flammability solid burning class: UL94V-0.

Important Notice:

- All rights are reserved. Reproduction in whole or in part is prohibited without the prior written approval of CYStek.
- CYStek reserves the right to make changes to its products without notice.
- CYStek **semiconductor products are not warranted to be suitable for use in Life-Support Applications, or systems.**
- CYStek assumes no liability for any consequence of customer product design, infringement of patents, or application assistance.