

BAS28
**SURFACE MOUNT SILICON
DUAL, ISOLATED HIGH SPEED
SWITCHING DIODES**



www.centrasemi.com

DESCRIPTION:

The CENTRAL SEMICONDUCTOR BAS28 consists of two electrically isolated ultra-high speed silicon switching diodes manufactured by the epitaxial planar process and packaged in an epoxy molded SOT-143 surface mount case. This device is designed for high speed switching applications.

MARKING CODE: A61 or JTW

MAXIMUM RATINGS: ($T_A=25^\circ\text{C}$)

Continuous Reverse Voltage
Peak Repetitive Reverse Voltage
Continuous Forward Current
Peak Repetitive Forward Current
Peak Forward Surge Current, $t_p=1.0\mu\text{s}$
Peak Forward Surge Current, $t_p=1.0\text{ms}$
Peak Forward Surge Current, $t_p=1.0\text{s}$
Power Dissipation
Operating and Storage Junction Temperature
Thermal Resistance

SYMBOL

V_R 75
 V_{RRM} 85
 I_F 250
 I_{FRM} 500
 I_{FSM} 4.0
 I_{FSM} 2.0
 I_{FSM} 1.0
 P_D 350
 T_J, T_{stg} -65 to +150
 θ_{JA} 357

UNITS

V
V
mA
mA
A
A
A
mW
 $^\circ\text{C}$
 $^\circ\text{C/W}$

ELECTRICAL CHARACTERISTICS PER DIODE: ($T_A=25^\circ\text{C}$ unless otherwise noted)

SYMBOL	TEST CONDITIONS	MIN	MAX	UNITS
I_R	$V_R=25\text{V}, T_A=150^\circ\text{C}$		30	μA
I_R	$V_R=75\text{V}$		1.0	μA
I_R	$V_R=75\text{V}, T_A=150^\circ\text{C}$		50	μA
V_F	$I_F=1.0\text{mA}$		715	mV
V_F	$I_F=10\text{mA}$		855	mV
V_F	$I_F=50\text{mA}$		1.00	V
V_F	$I_F=150\text{mA}$		1.25	V
C_J	$V_R=0, f=1.0\text{MHz}$		2.0	pF
t_{rr}	$I_F=I_R=10\text{mA}, I_{rr}=1.0\text{mA}, R_L=100\Omega$		6.0	ns
Q_s	$I_F=10\text{mA}, V_R=5.0\text{V}, R_L=500\Omega$		45	pC
V_{FR}	$I_F=10\text{mA}, t_f=20\text{ns}$		1.75	V

BAS28
SURFACE MOUNT SILICON
DUAL, ISOLATED HIGH SPEED
SWITCHING DIODES



SOT-143 CASE - MECHANICAL OUTLINE

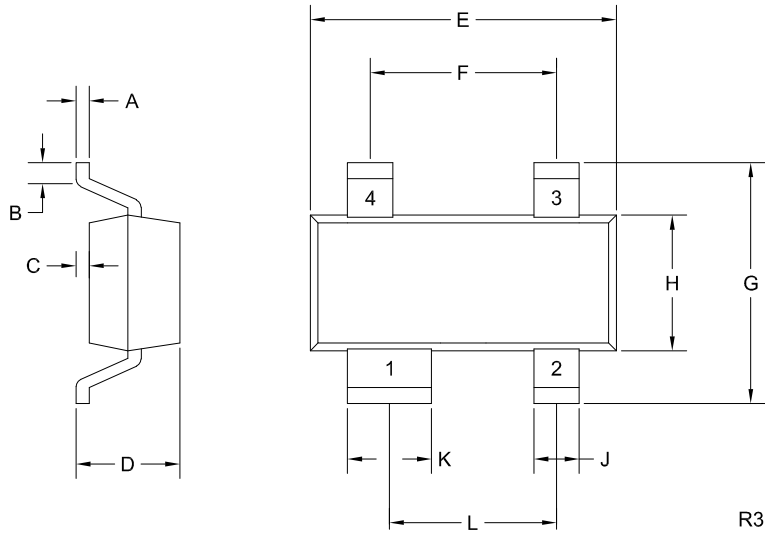

PIN CONFIGURATION

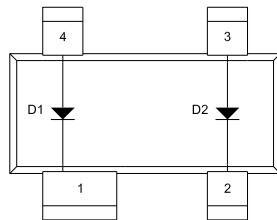

LEAD CODE:

- 1) Cathode D1
- 2) Cathode D2
- 3) Anode D2
- 4) Anode D1

SYMBOL	INCHES		MILLIMETERS	
	MIN	MAX	MIN	MAX
A	0.003	0.008	0.08	0.20
B	0.006	-	0.15	-
C	0.000	0.005	0.01	0.13
D	0.035	0.045	0.89	1.14
E	0.110	0.120	2.79	3.04
F	0.075		1.90	
G	0.083	0.102	2.10	2.60
H	0.047	0.055	1.19	1.40
J	0.012	0.020	0.30	0.50
K	0.030	0.037	0.76	0.93
L	0.067		1.70	

SOT-143 (REV: R3)

MARKING CODE: A61 or JTW

R8 (19-September 2018)

OUTSTANDING SUPPORT AND SUPERIOR SERVICES



PRODUCT SUPPORT

Central's operations team provides the highest level of support to insure product is delivered on-time.

- Supply management (Customer portals)
- Inventory bonding
- Consolidated shipping options
- Custom bar coding for shipments
- Custom product packing

DESIGNER SUPPORT/SERVICES

Central's applications engineering team is ready to discuss your design challenges. Just ask.

- Free quick ship samples (2nd day air)
- Online technical data and parametric search
- SPICE models
- Custom electrical curves
- Environmental regulation compliance
- Customer specific screening
- Up-screening capabilities
- Special wafer diffusions
- PbSn plating options
- Package details
- Application notes
- Application and design sample kits
- Custom product and package development

REQUESTING PRODUCT PLATING

1. If requesting Tin/Lead plated devices, add the suffix " TIN/LEAD" to the part number when ordering (example: 2N2222A TIN/LEAD).
2. If requesting Lead (Pb) Free plated devices, add the suffix " PBFREE" to the part number when ordering (example: 2N2222A PBFREE).

CONTACT US

Corporate Headquarters & Customer Support Team

Central Semiconductor Corp.
145 Adams Avenue
Hauppauge, NY 11788 USA
Main Tel: (631) 435-1110
Main Fax: (631) 435-1824
Support Team Fax: (631) 435-3388
www.centrasemi.com

Worldwide Field Representatives:
www.centrasemi.com/wwreps

Worldwide Distributors:
www.centrasemi.com/wwdistributors

For the latest version of Central Semiconductor's **LIMITATIONS AND DAMAGES DISCLAIMER**, which is part of Central's Standard Terms and Conditions of sale, visit: www.centrasemi.com/terms