

High –speed double diode

BAS299N3

Features

- Small plastic SMD package
- High switching speed: max. 4ns
- Continuous reverse voltage: max. 100V
- Repetitive peak reverse voltage: max. 110V
- Repetitive peak forward current: max. 900mA.
- Pb-free package

Equivalent Circuit

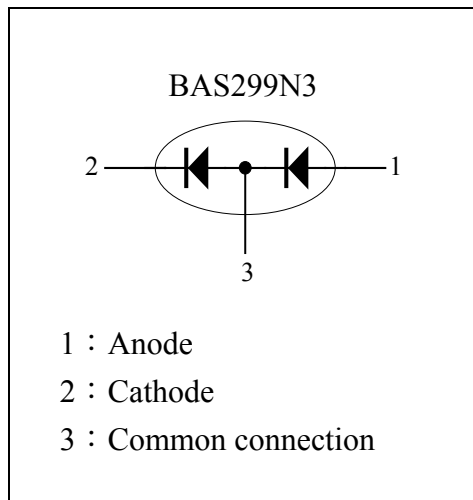

Outline

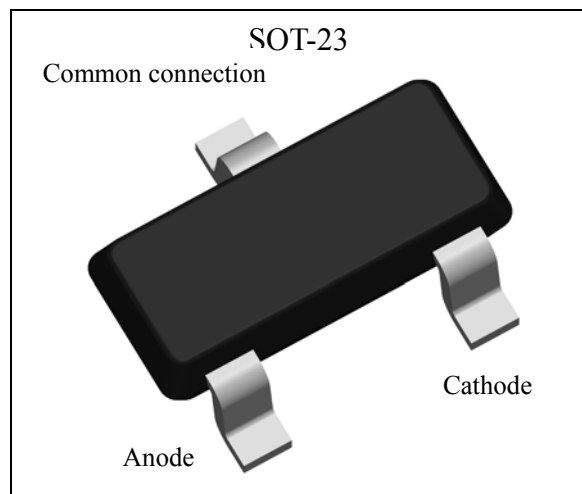

Ordering Information

Device	Package	Shipping
BAS299N3-0-T1-G	SOT-23 (Pb-free lead plating and halogen-free package)	3000 pcs / Tape & Reel

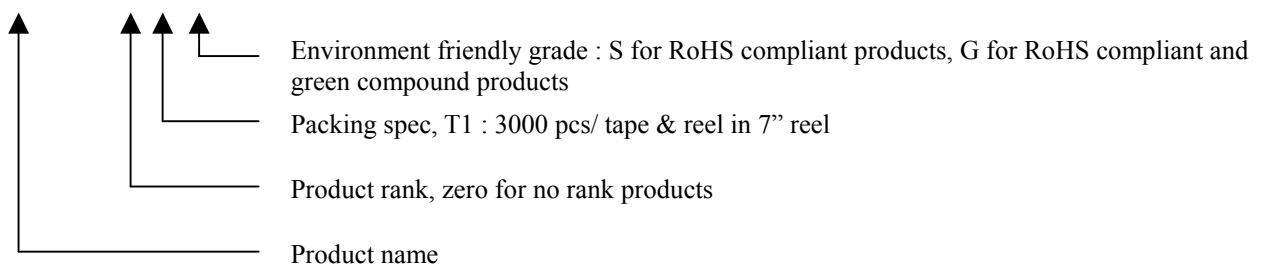

**Absolute Maximum Ratings @ $T_A=25^{\circ}\text{C}$**

Parameters	Symbol	Min	Max	Unit
Repetitive peak reverse voltage	V_{RRM}	-	110	V
Continuous reverse voltage	V_R	-	100	V
Continuous forward current(single diode loaded)	I_F	-	430	mA
Continuous forward current(double diode loaded)		-	250	
Repetitive peak forward current	I_{FRM}		900	mA
Non-repetitive peak forward current @square wave, $T_j=125^{\circ}\text{C}$ prior to surge	I_{FSM}	$t=1\mu\text{s}$	8	A
		$t=1\text{ms}$	2	A
		$t=1\text{s}$	1	A
Total power dissipation(Note 1)	P_{tot}		250	mW
Junction Temperature	T_j	-	150	$^{\circ}\text{C}$
Storage Temperature	T_{stg}	-65	+150	$^{\circ}\text{C}$

Note 1: Device mounted on an FR-4 PCB.

Electrical Characteristics @ $T_j=25^{\circ}\text{C}$ unless otherwise specified

Parameters	Symbol	Conditions	Min	Typ.	Max	Unit
Forward voltage	V_F	$I_F=1\text{mA}$	-	-	715	mV
		$I_F=10\text{mA}$	-	-	855	mV
		$I_F=50\text{mA}$	-	-	1	V
		$I_F=150\text{mA}$	-	-	1.2	V
		$I_F=300\text{mA}$	-	-	1.25	V
Reverse current	I_R	$V_R=25\text{V}$	-	-	30	nA
		$V_R=100\text{V}$	-	-	1	μA
		$V_R=25\text{V}, T_j=150^{\circ}\text{C}$	-	-	30	μA
		$V_R=100\text{V}, T_j=150^{\circ}\text{C}$	-	-	50	μA
Diode capacitance	C_d	$V_R=0\text{V}, f=1\text{MHz}$	-	-	3	pF
Reverse recovery time	t_{rr}	when switched from $I_F=10\text{mA}$ to $I_R=10\text{mA}, R_L=100\Omega$, measured at $I_R=1\text{mA}$	-	-	4	ns
Forward recovery voltage	V_{fr}	when switched from $I_F=10\text{mA}$ $t_r=20\text{ns}$	-	-	1.75	V

Thermal Characteristics

Symbol	Parameter	Conditions	Value	Unit
$R_{th,j-tp}$	thermal resistance from junction to tie-point		360	$^{\circ}\text{C}/\text{W}$
$R_{th,j-a}$	thermal resistance from junction to ambient	Note 1	500	$^{\circ}\text{C}/\text{W}$

Note 1: Device mounted on an FR-4 PCB.

Typical Characteristics

Power Derating Curve

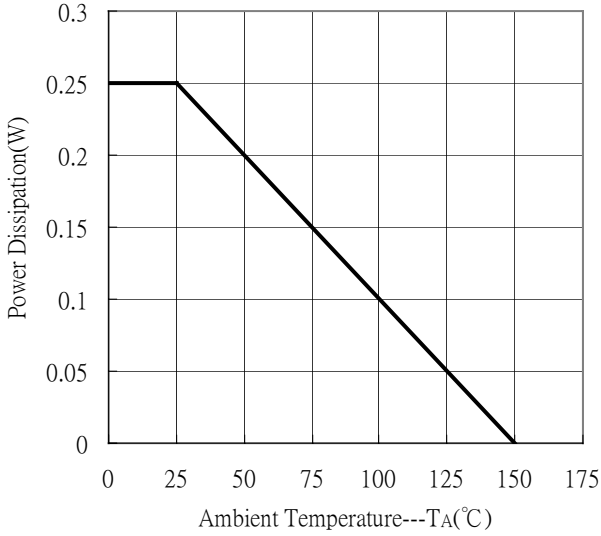

Forward Current vs Forward Voltage

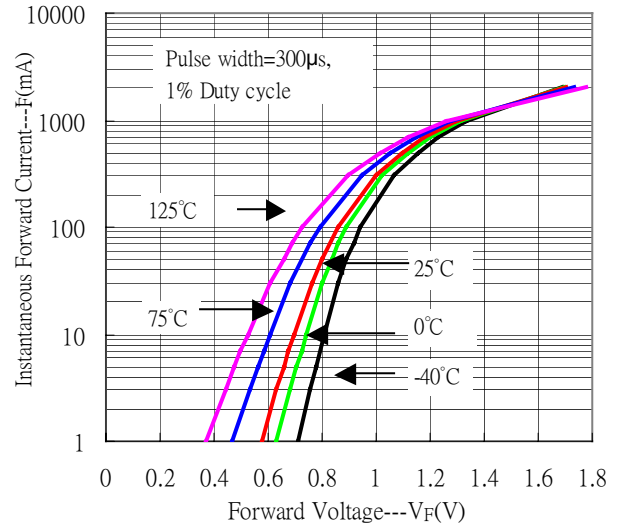

Reverse Leakage Current vs Reverse Voltage

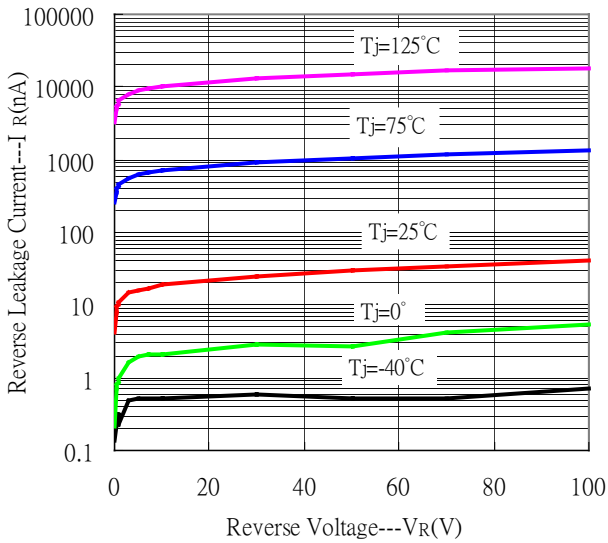

Junction Capacitance vs Reverse Voltage

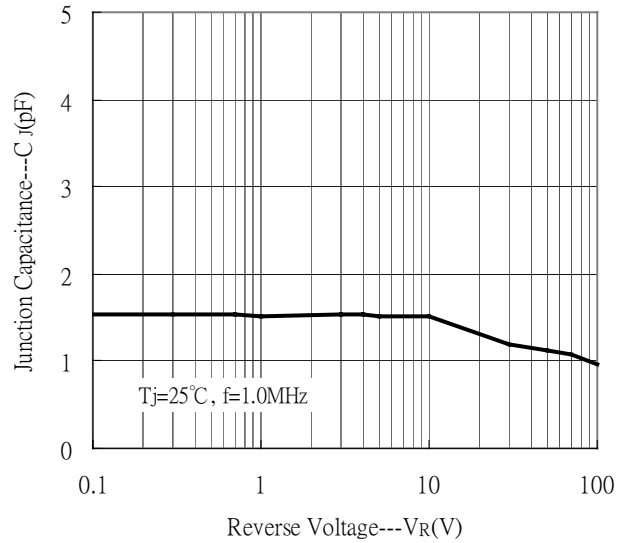

Recommended Soldering Footprint

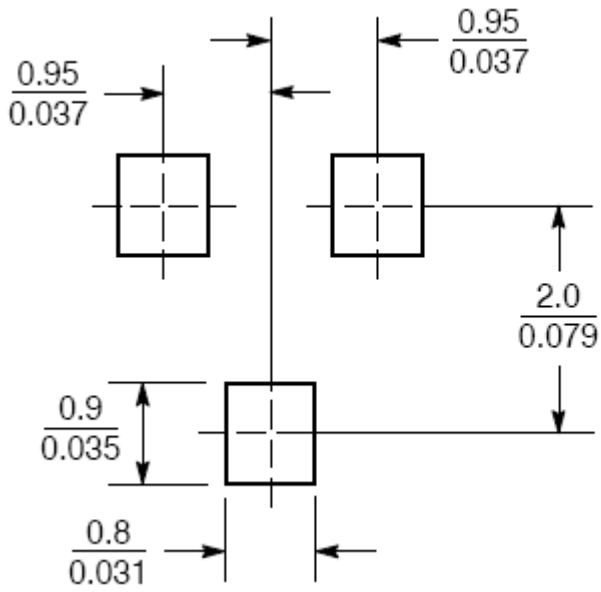

Unit : $\frac{\text{mm}}{\text{inches}}$

Reel Dimension

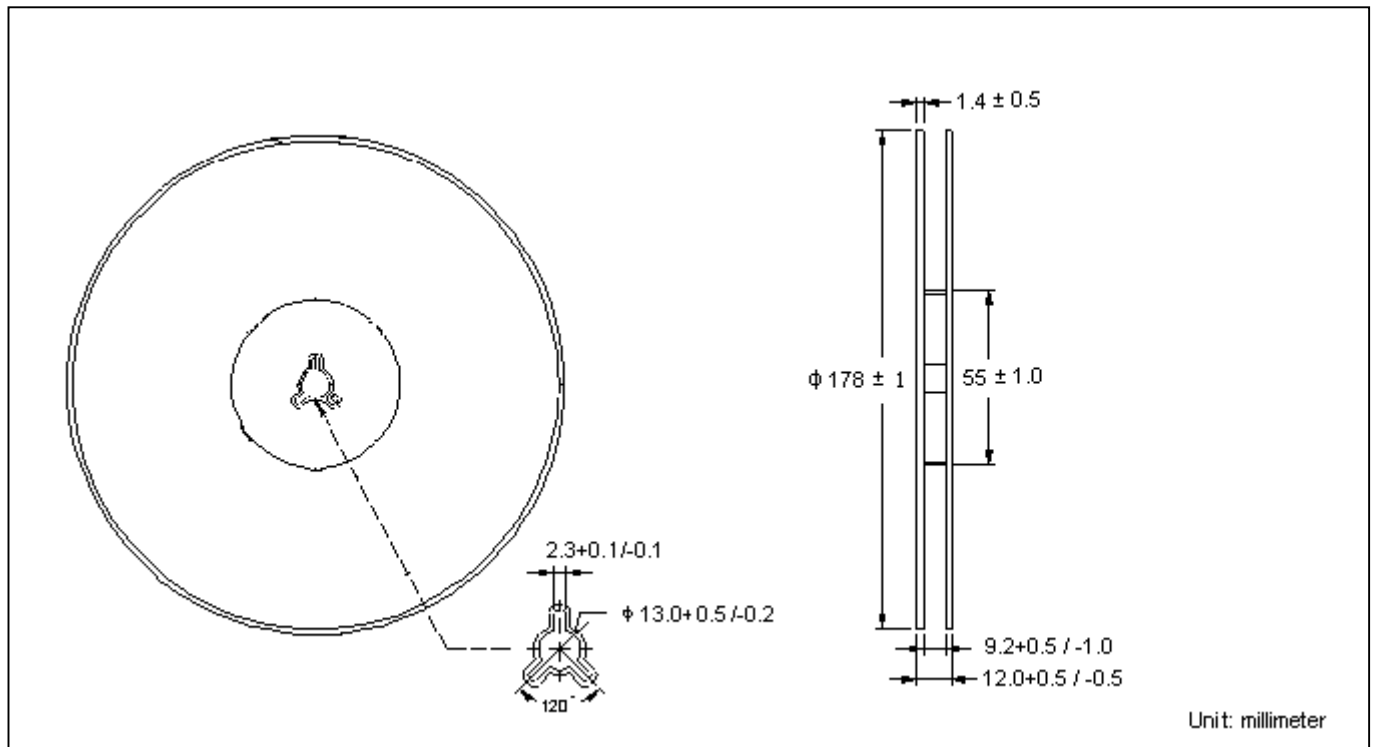

Carrier Tape Dimension

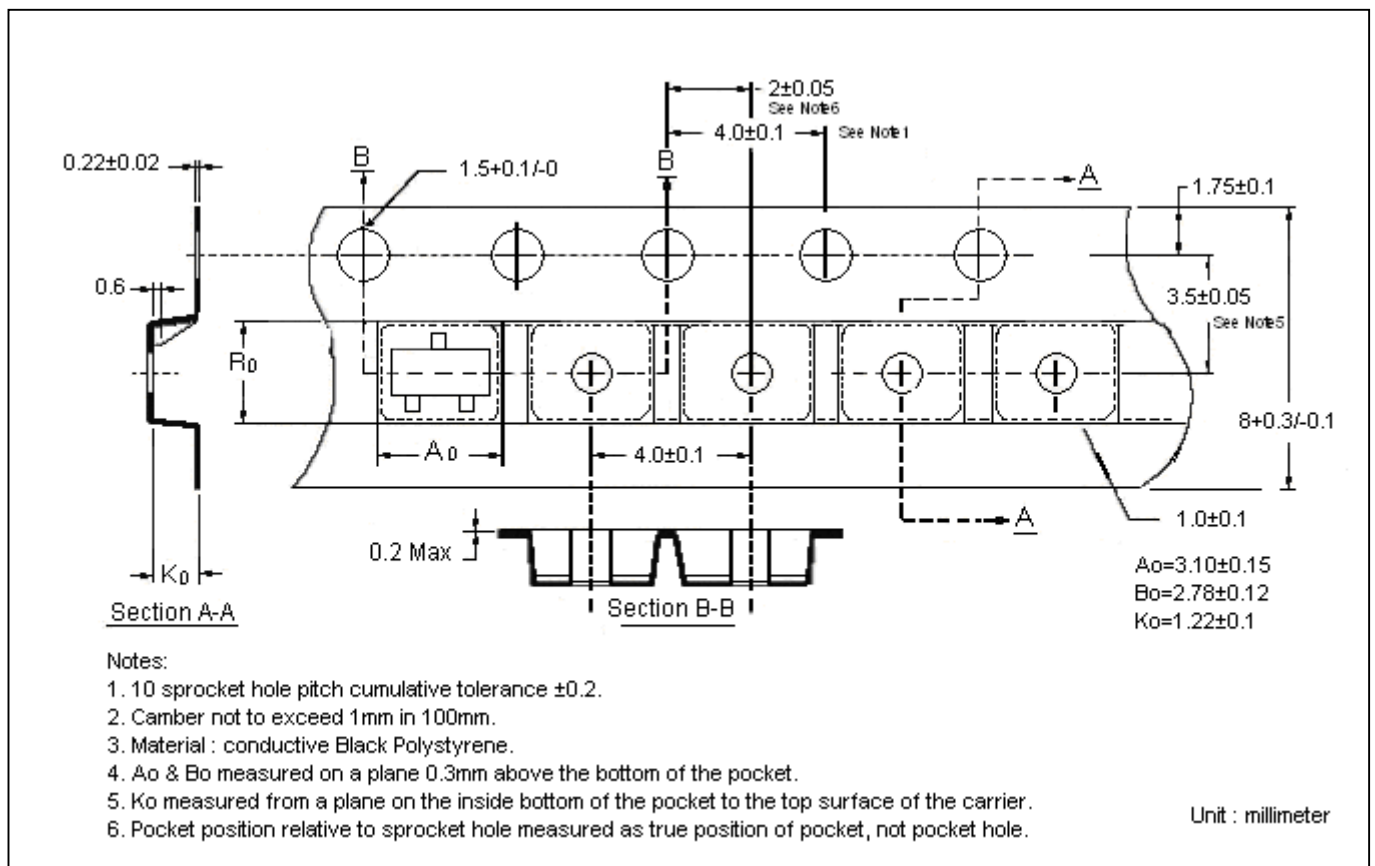

Recommended wave soldering condition

Product	Peak Temperature	Soldering Time
Pb-free devices	260 +0/-5 °C	5 +1/-1 seconds

Recommended temperature profile for IR reflow

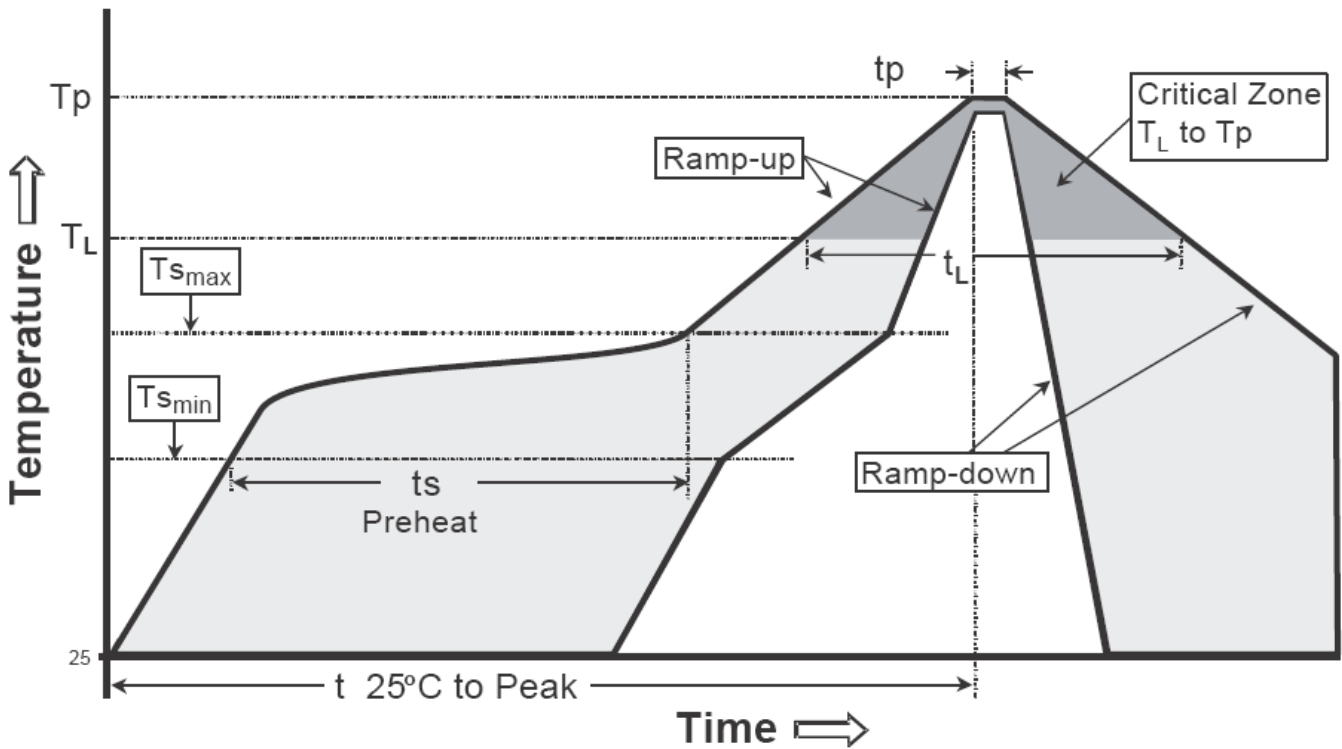

Profile feature	Sn-Pb eutectic Assembly	Pb-free Assembly
Average ramp-up rate (Tsmax to Tp)	3°C/second max.	3°C/second max.
Preheat		
-Temperature Min(Ts min)	100°C	150°C
-Temperature Max(Ts max)	150°C	200°C
-Time(ts min to ts max)	60-120 seconds	60-180 seconds
Time maintained above:		
-Temperature (Tl)	183°C	217°C
- Time (tl)	60-150 seconds	60-150 seconds
Peak Temperature(Tp)	240 +0/-5 °C	260 +0/-5 °C
Time within 5°C of actual peak temperature(tp)	10-30 seconds	20-40 seconds
Ramp down rate	6°C/second max.	6°C/second max.
Time 25 °C to peak temperature	6 minutes max.	8 minutes max.

Note :1. All temperatures refer to topside of the package, measured on the package body surface.
 2.For devices mounted on FR-4 PCB of 1.6mm or equivalent grade PCB. If other grade PCB is used, care should be taken to match the coefficients of thermal expansion between components and PCB. If they are not matched well, the solder joints may crack or the bodies of the parts may crack or shatter as the assembly cools.

SOT-23 Dimension

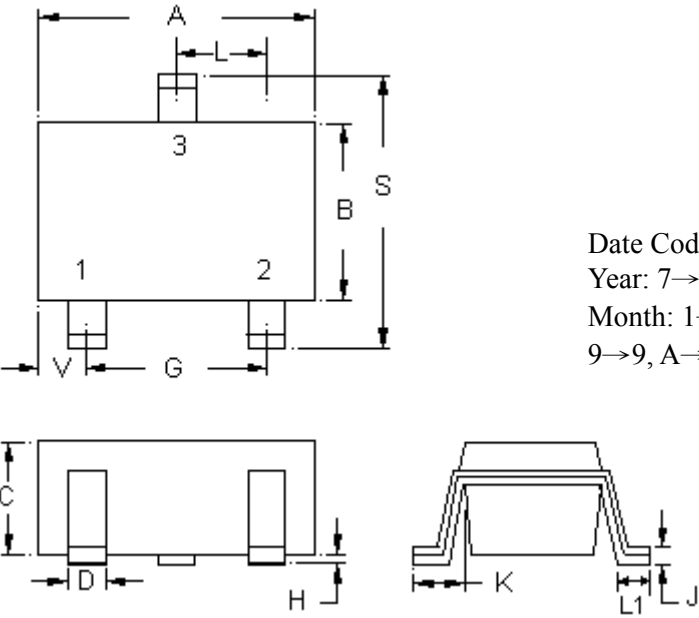

Product Code

Date Code: Year+Month
 Year: 7→2017, 8→2018
 Month: 1→1, 2→2, . . .
 9→9, A→10, B→11, C→12

Marking:

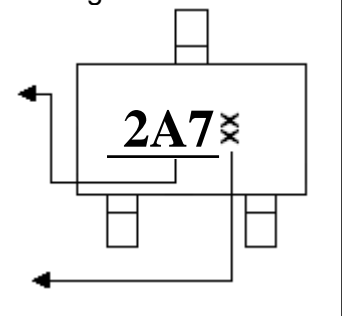

3-Lead SOT-23 Plastic
 Surface Mounted Package
 CYStek Package Code: N3

Style: Pin 1.Anode 2.Cathode
 3.Common connection

*:Typical

DIM	Inches		Millimeters		DIM	Inches		Millimeters	
	Min.	Max.	Min.	Max.		Min.	Max.	Min.	Max.
A	0.1102	0.1204	2.80	3.04	J	0.0032	0.0079	0.08	0.20
B	0.0472	0.0669	1.20	1.70	K	0.0118	0.0266	0.30	0.67
C	0.0335	0.0512	0.89	1.30	L	0.0335	0.0453	0.85	1.15
D	0.0118	0.0197	0.30	0.50	S	0.0830	0.1161	2.10	2.95
G	0.0669	0.0910	1.70	2.30	V	0.0098	0.0256	0.25	0.65
H	0.0000	0.0040	0.00	0.10	L1	0.0118	0.0197	0.30	0.50

Notes : 1.Controlling dimension : millimeters.
 2.Maximum lead thickness includes lead finish thickness, and minimum lead thickness is the minimum thickness of base material.
 3.If there is any question with packing specification or packing method, please contact your local CYStek sales office.

Material :

- Lead : Pure tin plated.
- Mold Compound : Epoxy resin family, flammability solid burning class:UL94V-0.

Important Notice:

- All rights are reserved. Reproduction in whole or in part is prohibited without the prior written approval of CYStek.
- CYStek reserves the right to make changes to its products without notice.
- CYStek **semiconductor products are not warranted to be suitable for use in Life-Support Applications, or systems.**
- CYStek assumes no liability for any consequence of customer product design, infringement of patents, or application assistance.