

BAT54/BAT54A/BAT54C/BAT54S Schottky Diode

Features

- Low forward voltage
- Low turn-on voltage
- Fast switching

Applications

- High speed switching
- Voltage clamping
- Protection circuits



SOT-23

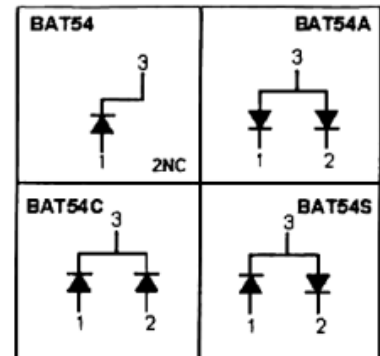

Absolute Maximum Ratings $(T_A = 25^\circ\text{C}$ unless otherwise noted)

Parameter	Symbol	Value	Unit
Peak Repetitive Peak reverse voltage	V_{RRM}	30	V
Working Peak Reverse Voltage	V_{RWM}		
DC Reverse Voltage	V_R		
Forward Continuous Current	I_F	200	mA
Repetitive Peak Forward Current	I_{FRM}	300	mA
Forward surge current @ $t < 1.0\text{s}$	I_{FSM}	600	mA
Power Dissipation	P_D	200	mW
Thermal resistance, junction to ambient air	$R_{\theta JA}$	500	$^\circ\text{C}/\text{W}$
Operating and Storage temperature	T_J, T_{STG}	-65 to +150	$^\circ\text{C}$

Electrical Characteristics $(T_A = 25^\circ\text{C}$ unless otherwise noted)

Parameter	Symbol	Min.	Max.	Unit	Conditions
Reverse Breakdown Voltage	$V_{(BR)}$	30	-	V	$I_R = 100\mu\text{A}$
Forward voltage	V_{F1}	-	0.24	V	$I_F = 0.1\text{mA}$
		-	0.32	V	$I_F = 1\text{mA}$
		-	0.40	V	$I_F = 10\text{mA}$
		-	0.50	V	$I_F = 30\text{mA}$
		-	1	V	$I_F = 100\text{mA}$
Reverse current	I_R	-	2	μA	$V_R = 25\text{V}$
Diode Capacitance	C_D	-	10	pF	$V_R = 1\text{V}, f = 1\text{MHz}$
Reverse Recovery Time	t_{rr}	-	5	ns	$I_F = I_R = 10\text{mA}$ $I_{rr} = 0.1 \times I_R, R_L = 100\Omega$

Ratings and Characteristics Curves ($T_A = 25^\circ\text{C}$ unless otherwise noted)

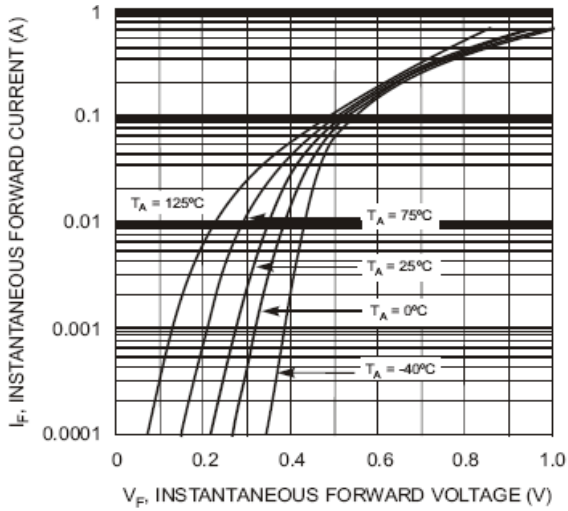

Fig. 1 Forward Characteristics

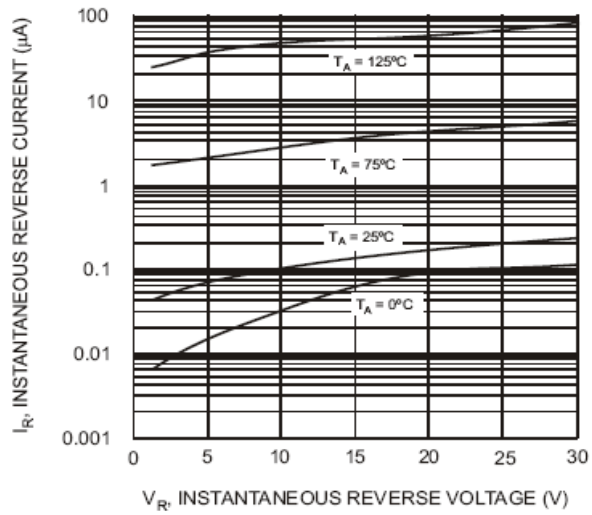

Fig. 2 Typical Reverse Characteristics

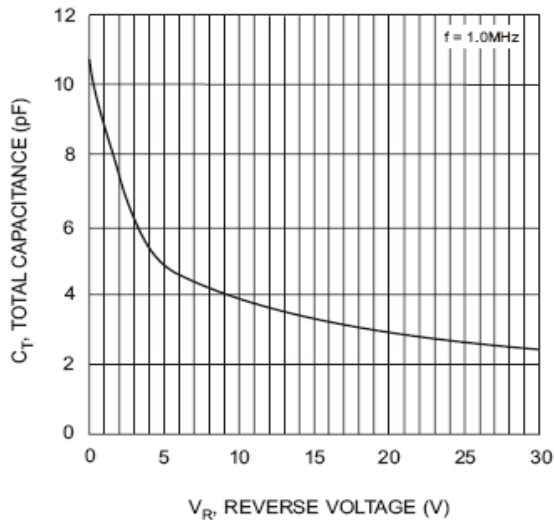

Fig. 3 Typical Capacitance vs. Reverse Voltage

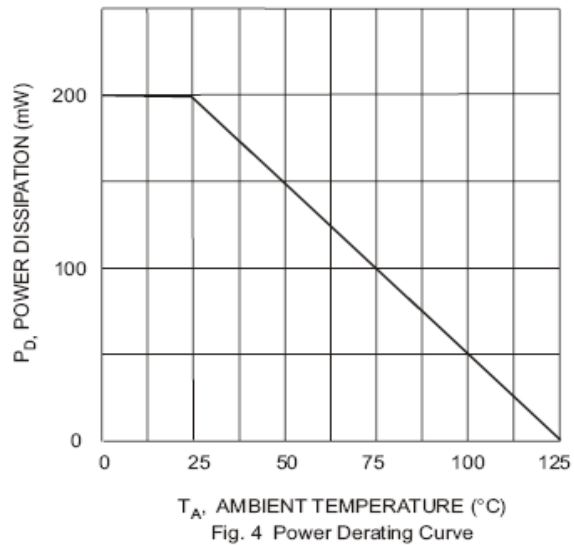
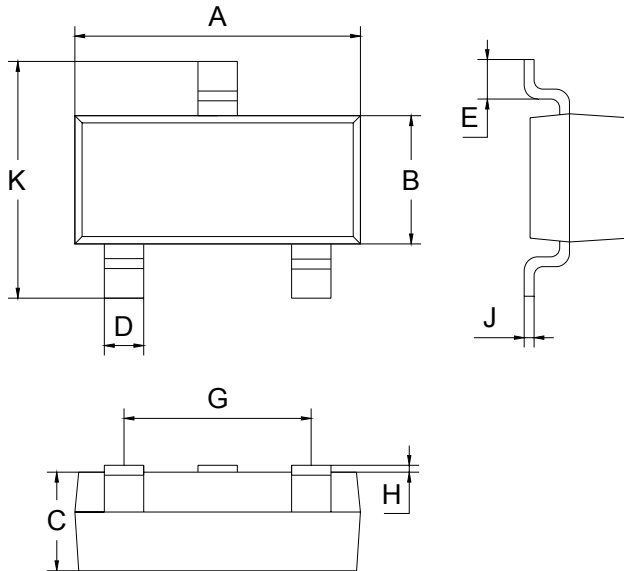

Fig. 4 Power Derating Curve

BAT54/BAT54A/BAT54C/BAT54S Schottky Diode

Package Outline Dimensions (SOT-23 in millimeters)



SOT-23		
Dim	Min	Max
A	2.70	3.10
B	1.10	1.50
C	1.0 Typical	
D	0.4 Typical	
E	0.35	0.48
G	1.80	2.00
H	0.02	0.1
J	0.1 Typical	
K	2.20	2.60
All Dimensions in mm		

Suggested Pad Layout Unit : mm

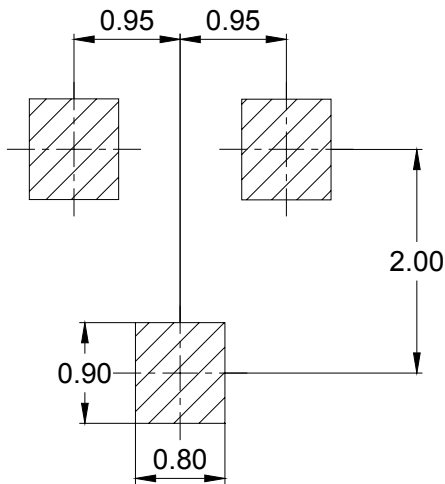

Marking Information

P/N	BAT54	BAT54A	BAT54C	BAT54S
Marking	KL1	KL2	KL3	KL4