

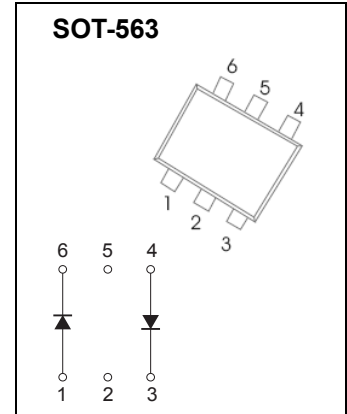

## SOT-563 Plastic-Encapsulate Diodes

### BAT54V

SCHOTTKY BARRIER DIODE



### FEATURES

Surface mount schottky barrier diode arrays

### Marking: KAV

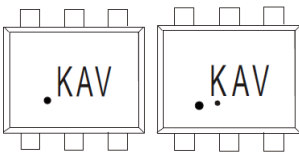

Solid dot = Green molding compound device, if none, the normal device.

Solid dot = Pin1 indicate.

### Maximum Ratings @Ta=25°C

Parameter	Symbol	Limit	Unit
Peak Repetitive Peak Reverse Voltage	$V_{RRM}$	30	V
Working Peak Reverse Voltage	$V_{RWM}$		
DC Blocking Voltage	$V_R$		
Average Rectified Output Current	$I_O$	200	mA
Non-repetitive Peak Forward Surge Current @ t=8.3ms	$I_{FSM}$	600	mA
Repetitive Peak Forward Current @ t≤1s, δ≤0.5	$I_{FRM}$	300	mA
Power Dissipation	$P_D$	150	mW
Thermal Resistance Junction to Ambient	$R_{θJA}$	667	°C/W
Junction Temperature	$T_J$	125	°C
Storage Temperature	$T_{STG}$	-65-125	°C

### ELECTRICAL CHARACTERISTICS (Ta=25°C unless otherwise specified)

Parameter	Symbol	Test conditions	Min	Max	Unit
Reverse breakdown voltage	$V_{(BR)}$	$I_R=100\mu A$	30		V
Reverse voltage leakage current	$I_R$	$V_R=25V$		2	uA
Forward voltage	$V_F$	$I_F=1mA$		320	mV
		$I_F=10mA$		400	
		$I_F=30mA$		500	
		$I_F=100mA$		1000	
Total capacitance	$C_T$	$V_R=1V, f=1MHz$		10	pF
Reverse recovery time	$t_{rr}$	$I_F=10mA, I_R=10mA\sim 1mA$ $R_L=100\Omega$		5	ns

# Typical Characteristics

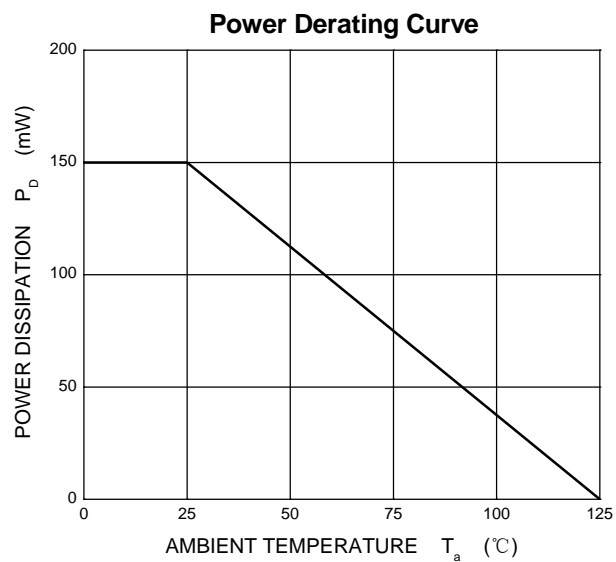
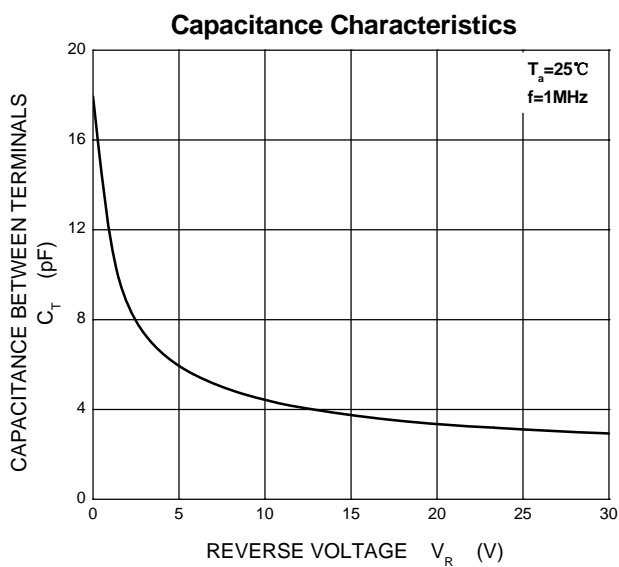
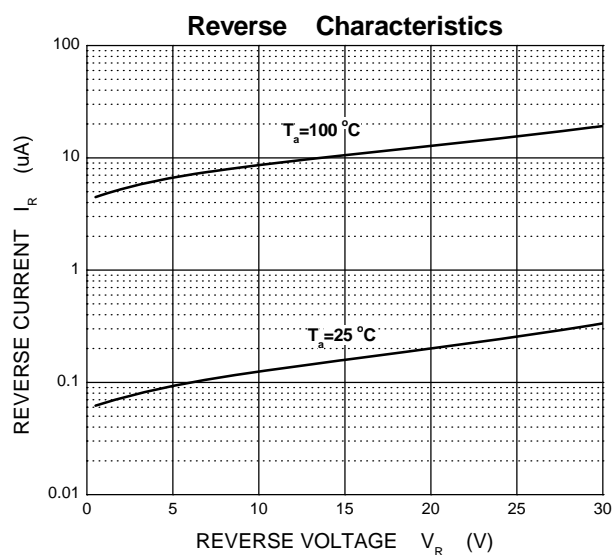
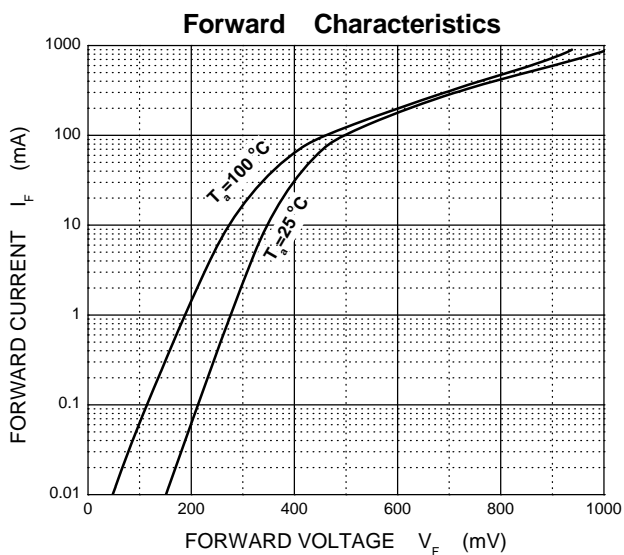

## SOT-563 Package Outline Dimensions

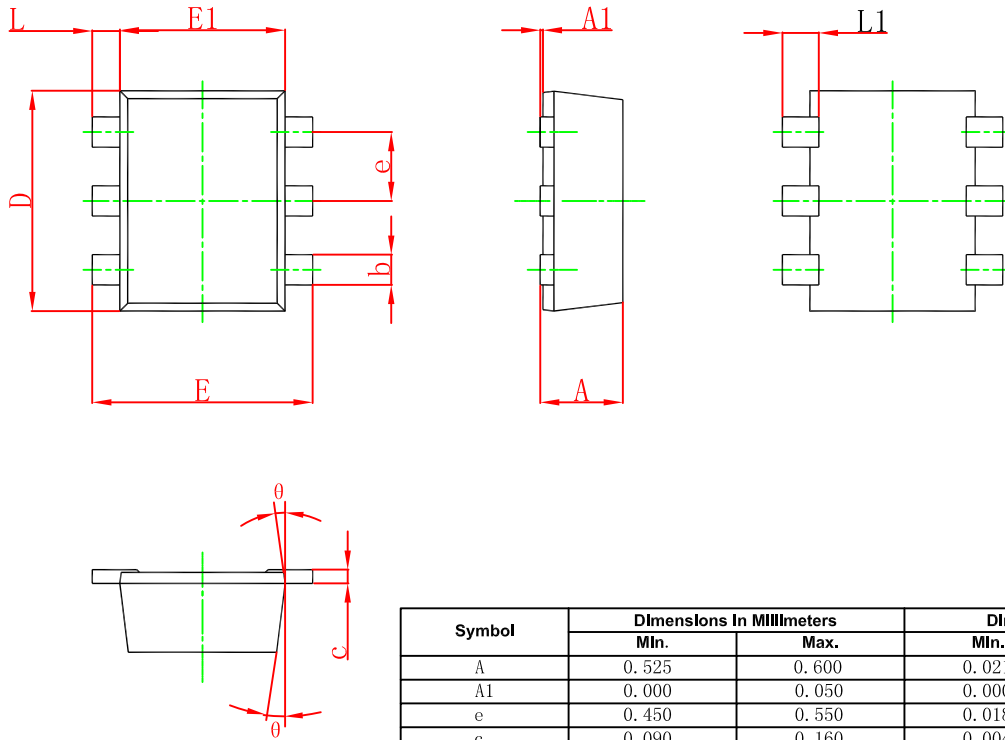

Symbol	Dimensions In Millimeters		Dimensions In Inches	
	Min.	Max.	Min.	Max.
A	0.525	0.600	0.021	0.024
A1	0.000	0.050	0.000	0.002
e	0.450	0.550	0.018	0.022
c	0.090	0.160	0.004	0.006
D	1.500	1.700	0.059	0.067
b	0.170	0.270	0.007	0.011
E1	1.100	1.300	0.043	0.051
E	1.500	1.700	0.059	0.067
L	0.100	0.300	0.004	0.012
L1	0.200	0.400	0.008	0.016
$\theta$	7 °REF.		7 °REF.	

## SOT-563 Suggested Pad Layout

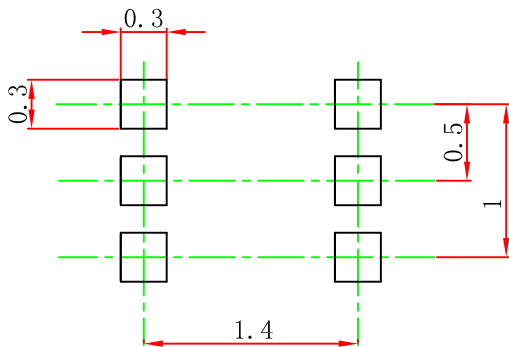

Note:

1. Controlling dimension: in millimeters.
2. General tolerance:  $\pm 0.05\text{mm}$ .
3. The pad layout is for reference purposes only.

### NOTICE

JCET reserve the right to make modifications, enhancements, improvements, corrections or other changes without further notice to any product herein. JCET does not assume any liability arising out of the application or use of any product described herein.

# SOT-563 Tape and Reel

## SOT-563 Embossed Carrier Tape

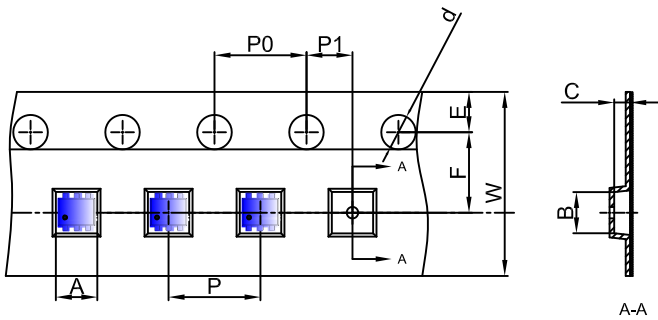

### Packaging Description:

SOT-563 parts are shipped in tape. The carrier tape is made from a dissipative (carbon filled) polycarbonate resin. The cover tape is a multilayer film (Heat Activated Adhesive in nature) primarily composed of polyester film, adhesive layer, sealant, and anti-static sprayed agent. These reeled parts in standard option are shipped with 3,000 units per 7" or 17.8cm diameter reel. The reels are clear in color and is made of polystyrene plastic (anti-static coated).

Dimensions are in millimeter										
Pkg type	A	B	C	d	E	F	P0	P	P1	W
SOT-563	1.78	1.78	0.69	Ø1.50	1.75	3.50	4.00	4.00	2.00	8.00

## SOT-563 Tape Leader and Trailer

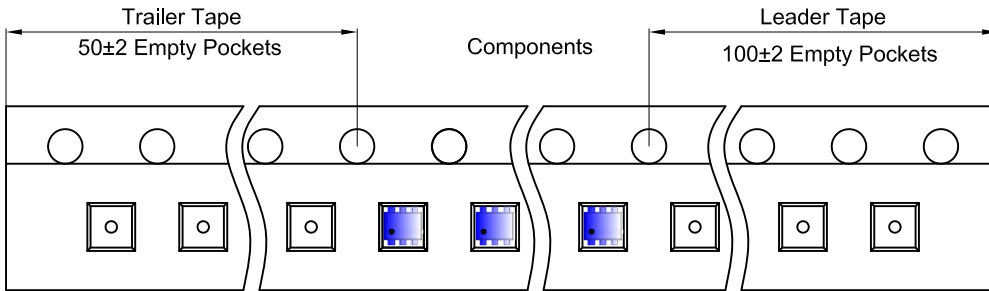

## SOT-563 Reel

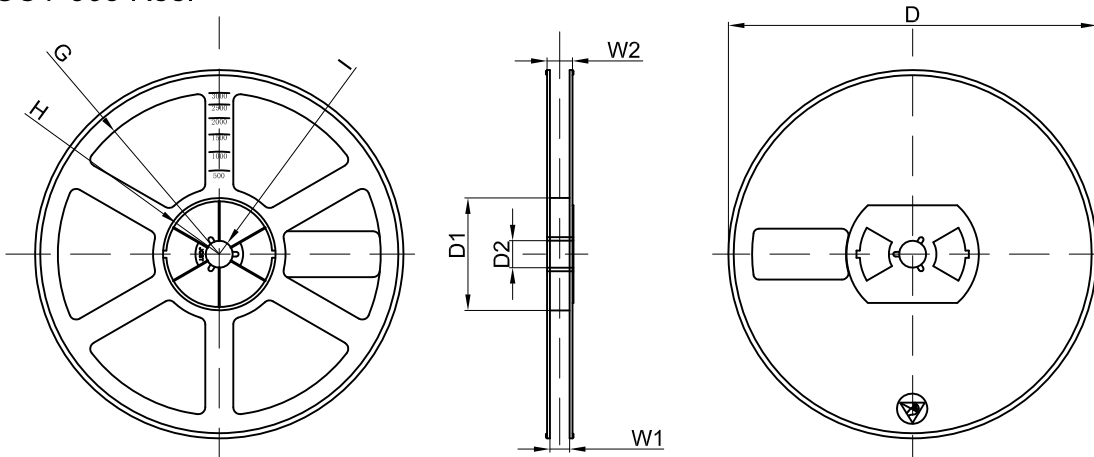

Dimensions are in millimeter								
Reel Option	D	D1	D2	G	H	I	W1	W2
7" Dia	Ø178.00	54.40	13.00	R78.00	R25.60	R6.50	9.50	12.30

REEL	Reel Size	Box	Box Size(mm)	Carton	Carton Size(mm)	G.W.(kg)
3000 pcs	7 inch	45,000 pcs	203×203×195	180,000 pcs	438×438×220	