

PRIMARY CHARACTERISTICS	
P_D	150mV
V_{RRM}	30V
I_F	300mA
$V_F@I_F=100mA$	1.0V
$T_{J Max}$	125°C

SOT-563 PACKAGE

Marking: KAV

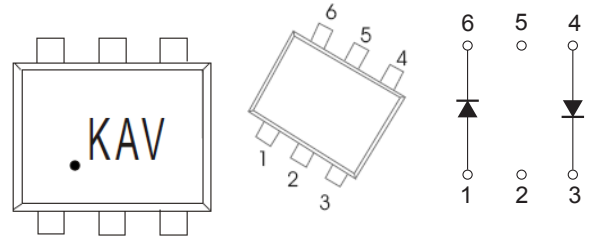

FEATURES

- Surface mount schottky barrier diode arrays
- Moisture Sensitivity Level 1

MECHANICAL DATA

- Case : Molded plastic,SOT-563
- Polarity : Shown above
- Terminals :Plated terminals, solderable per MIL-STD-750,Method 2026
- Epoxy : UL94-V0 rated flame retardant

Maximum Ratings @Ta=25°C

Parameter	Symbol	Limit	Unit
Peak Repetitive Peak Reverse Voltage Working Peak Reverse Voltage DC Blocking Voltage	V_{RRM} V_{RWM} V_R	30	V
Average Rectified Output Current	I_O	200	mA
Non-repetitive Peak Forward Surge Current @ t=8.3ms	I_{FSM}	600	mA
Repetitive Peak Forward Current @ t≤1s, δ ≤0.5	I_{FRM}	300	mA
Power Dissipation	P_D	150	mW
Thermal Resistance Junction to Ambient	$R_{θJA}$	667	°C/W
Junction Temperature	T_J	125	°C
Storage Temperature	T_{STG}	-65-125	°C

ELECTRICAL CHARACTERISTICS (Ta=25°C unless otherwise specified)

Parameter	Symbol	Test conditions	Min	Max	Unit
Reverse breakdown voltage	$V_{(BR)}$	$I_R=100\mu A$	30		V
Reverse voltage leakage current	I_R	$V_R=25V$		2	μA
Forward voltage	V_F	$I_F=1mA$ $I_F=10mA$ $I_F=30mA$ $I_F=100mA$		320 400 500 1000	mV
Total capacitance	C_T	$V_R=1V, f=1MHz$		10	pF
Reverse recovery time	t_{rr}	$I_F=10mA, I_R=10mA\sim 1mA$ $R_L=100\Omega$		5	ns

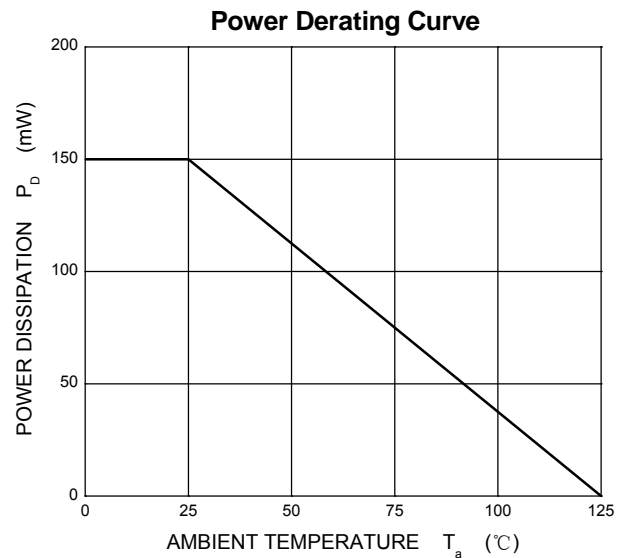
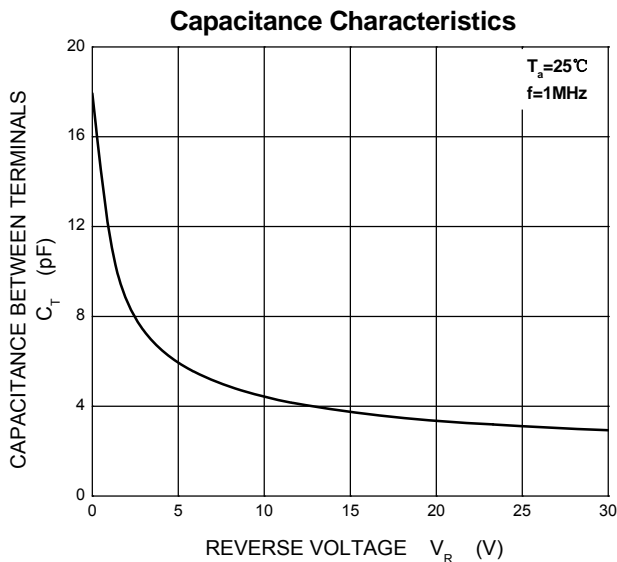
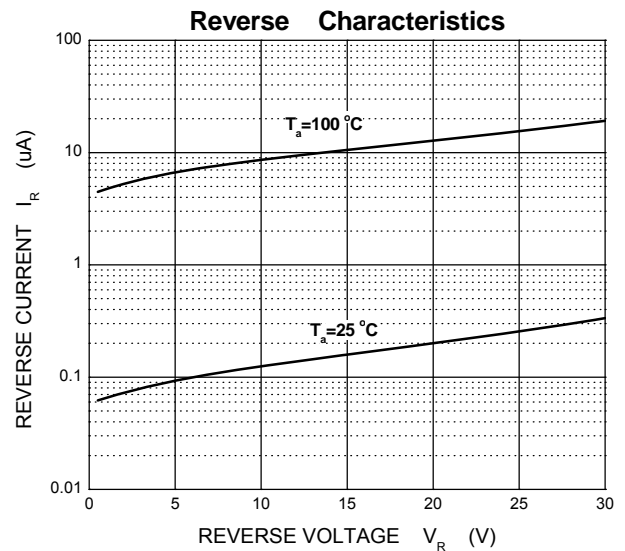
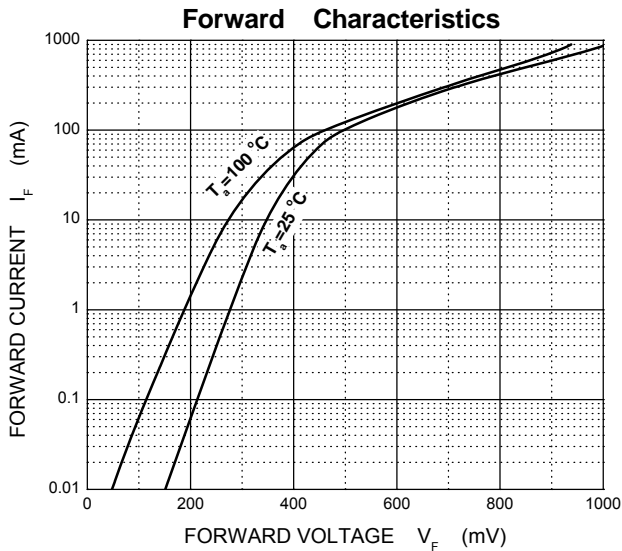
Typical Characteristics

Outline Drawing

SOT-563

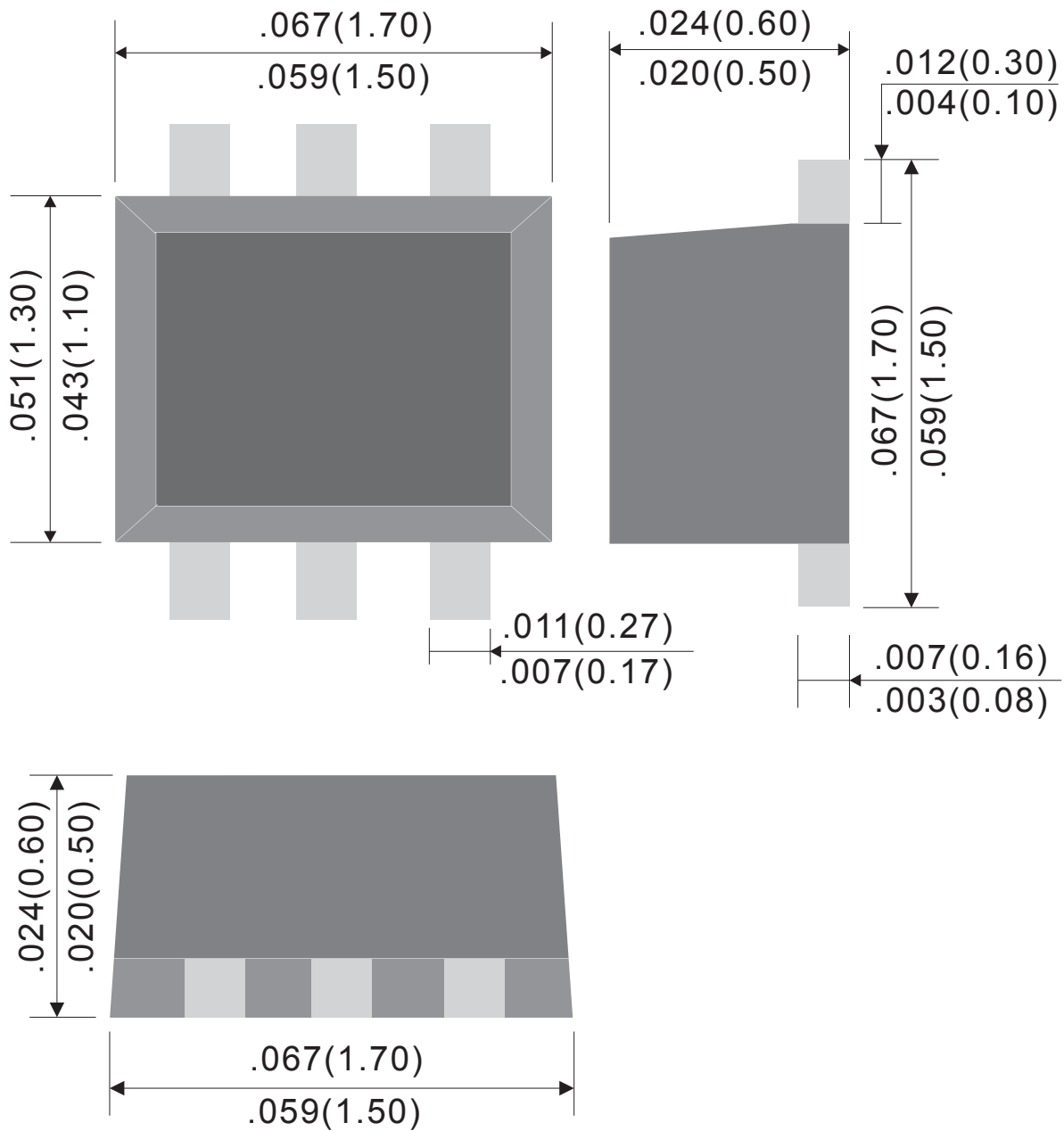

Dimensions in inches and (millimeters)

Rev.A

SOT-563 Embossed Carrier Tape

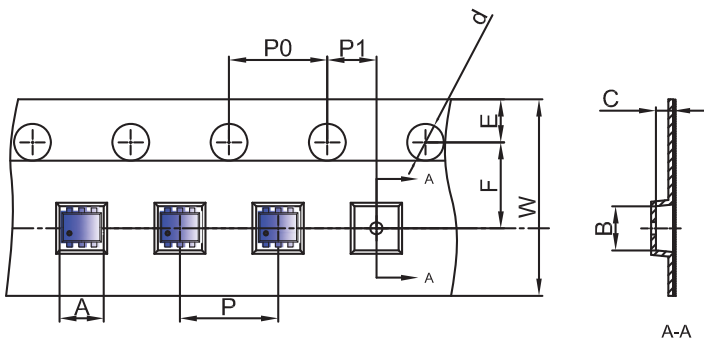

Packaging Description:

SOT-563 parts are shipped in tape. The carrier tape is made from a dissipative (carbon filled) polycarbonate resin. The cover tape is a multilayer film (Heat Activated Adhesive in nature) primarily composed of polyester film, adhesive layer, sealant, and anti-static sprayed agent. These reeled parts in standard option are shipped with 3,000 units per 7" or 17.8cm diameter reel. The reels are clear in color and is made of polystyrene plastic (anti-static coated).

Dimensions are in millimeter										
Pkg type	A	B	C	d	E	F	P0	P	P1	W
SOT-563	1.78	1.78	0.69	Ø1.50	1.75	3.50	4.00	4.00	2.00	8.00
(Tolerance)	+/-0.1	+/-0.1	+/-0.1	+/-0.1	+/-0.1	+/-0.1	+/-0.1	+/-0.1	+/-0.1	+/-0.1

SOT-563 Tape Leader and Trailer

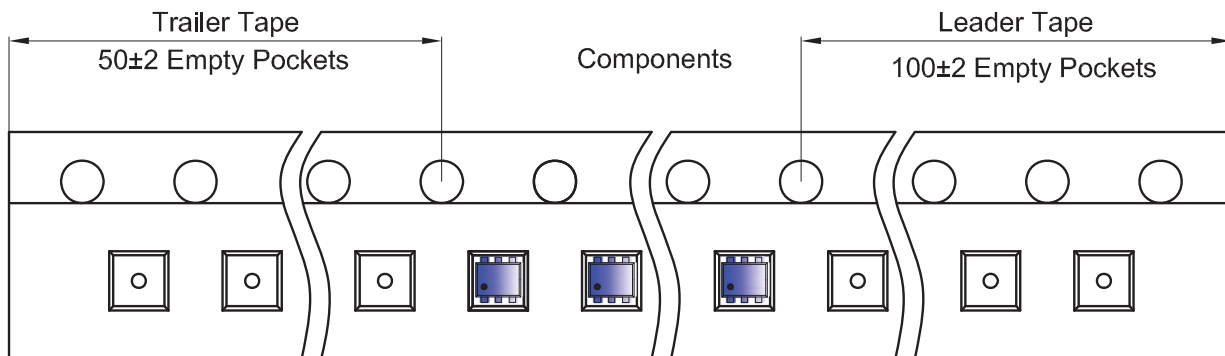

SOT-563 Reel

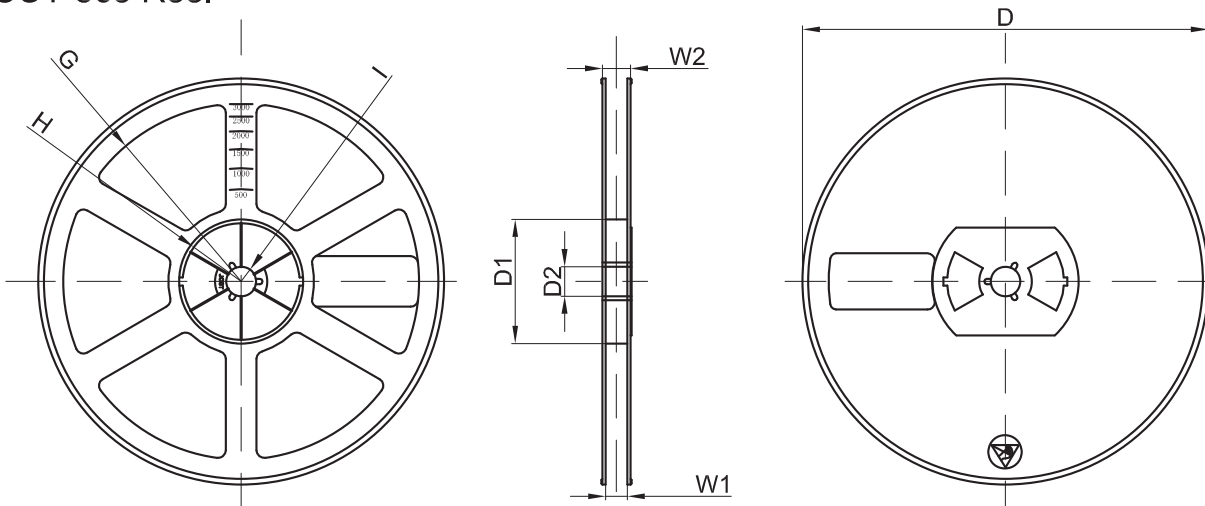

Dimensions are in millimeter								
Reel Option	D	D1	D2	G	H	I	W1	W2
7" Dia	Ø178.00	54.40	13.00	R78.00	R25.60	R6.50	9.50	12.30
Tolerance	+/-2	+/-1	+/-1	+/-1	+/-1	+/-1	+/-1	+/-1

REEL	Reel Size	Box	Box Size(mm)	Carton	Carton Size(mm)	G.W.(kg)
3000 pcs	7 inch	45,000 pcs	203×203×195	180,000 pcs	438×438×220	

Ordering Information:

Device PN	Packing
BAT54V -T ⁽¹⁾ G ⁽²⁾ -WS	Tape&Reel: 3 Kpcs/Reel

Note: (1) Packing code, Tape & Reel Packing

(2) RoHS product for packing code suffix "G" ; Halogen free product for packing code suffix "H"

*****Disclaimer*****

WILLAS reserves the right to make changes without notice to any product specification herein, to make corrections, modifications, enhancements or other changes. WILLAS or anyone on its behalf assumes no responsibility or liability for any errors or inaccuracies. Data sheet specifications and its information contained are intended to provide a product description only. "Typical" parameters which may be included on WILLAS data sheets and/ or specifications can and do vary in different applications and actual performance may vary over time. WILLAS does not assume any liability arising out of the application or use of any product or circuit.

WILLAS products are not designed, intended or authorized for use in medical, life-saving implant or other applications intended for life-sustaining or other related applications where a failure or malfunction of component or circuitry may directly or indirectly cause injury or threaten a life without expressed written approval of WILLAS. Customers using or selling WILLAS components for use in such applications do so at their own risk and shall agree to fully indemnify WILLAS Inc and its subsidiaries harmless against all claims, damages and expenditures.