

Schottky Barrier Diode

BAT54X

FEATURES

- Extremely fast switching speed.
- Low forward voltage—0.35v(Typ).

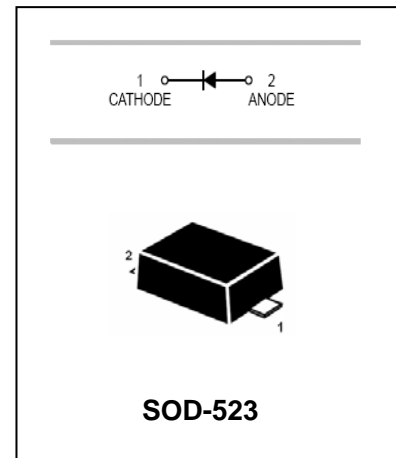

APPLICATIONS

- High speed switching application.

ORDERING INFORMATION

Type No.	Marking	Package Code
BAT54X	JV	SOD-523

MAXIMUM RATING @ Ta=25°C unless otherwise specified

Parameter	Symbol	Limits	Unit
DC Reverse voltage	V_R	30	V
Continuous forward current	I_F	200	mA
Peak forward surge current	I_{FSM}	600	mA
Total power dissipation	P_{tot}	200	mW
Total resistance junction to ambient	$R_{\theta JA}$	635	°C/W
Junction temperature	T_j	150	°C
Storage temperature	T_{stg}	-55 to +150	°C

ELECTRICAL CHARACTERISTICS @ Ta=25°C unless otherwise specified

Parameter	Symbol	Min.	Typ.	Max.	Unit	Conditions
Reverse breakdown voltage	$V_{(BR)R}$	30			V	$I_R=100\mu A$
Forward voltage	V_F		0.22 0.41 0.52 0.29 0.35	0.24 0.5 0.8 0.32 0.40	V	$I_F=0.1mA$ $I_F=30mA$ $I_F=100mA$ $I_F=1.0mA$ $I_F=10mA$
Reverse current	I_R		0.5	2.0	μA	$V_R=25V$
Diode capacitance	C_d		7.6	10	pF	$V_R=1V, f=1MHz$
Reverse recovery time	t_{rr}			5	ns	$I_F=I_R=10mA$

Schottky Barrier Diode

BAT54X

TYPICAL CHARACTERISTICS @ $T_a=25^\circ\text{C}$ unless otherwise specified

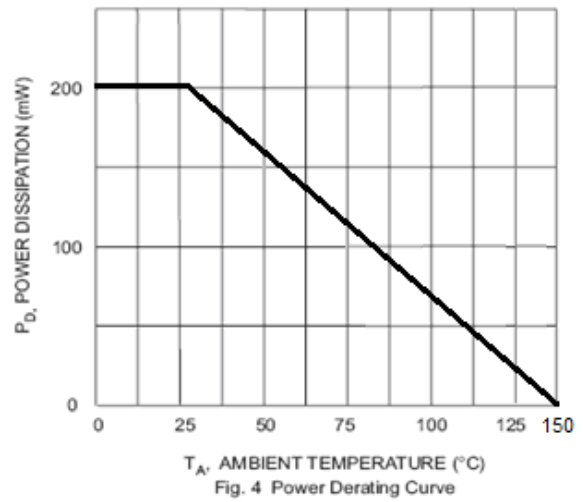
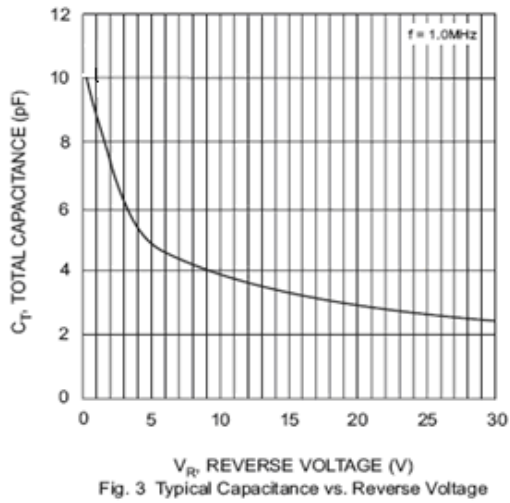
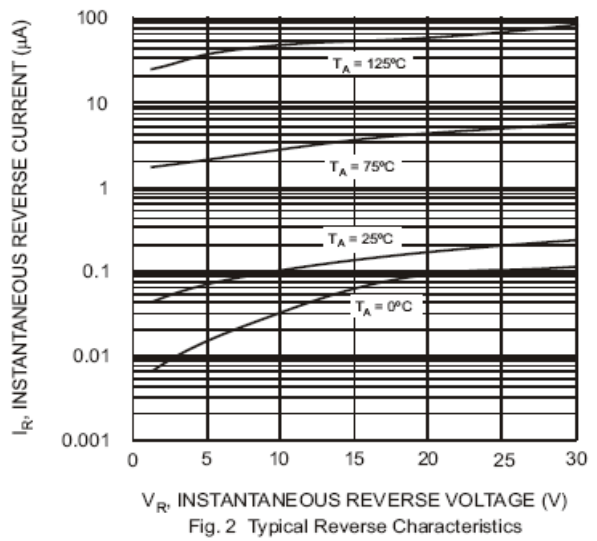
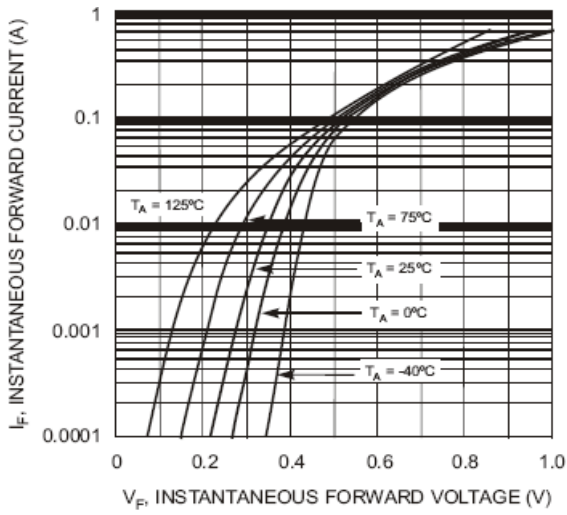

Schottky Barrier Diode

BAT54X

PACKAGE OUTLINE

Plastic surface mounted package

SOD-523

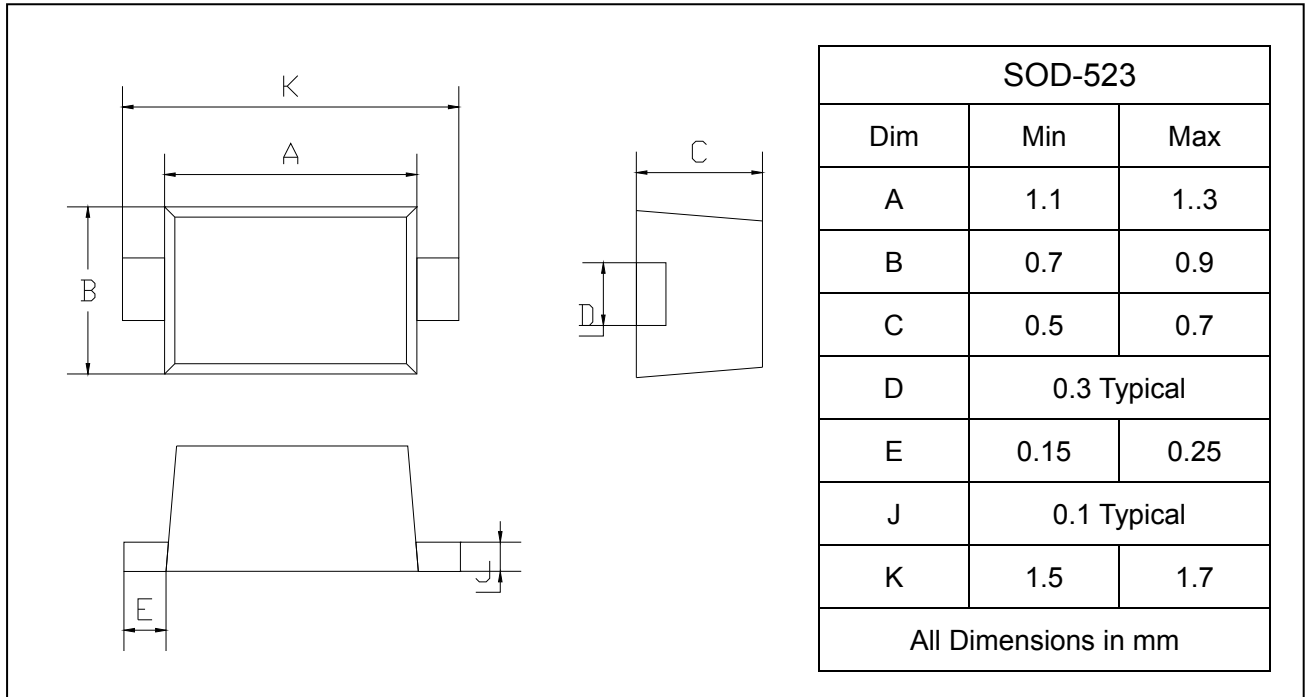

SOLDERING FOOTPRINT

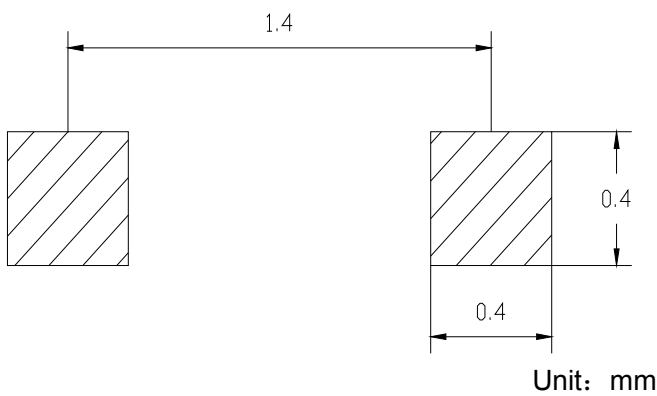

PACKAGE INFORMATION

Device	Package	Shipping
BAT54X	SOD-523	3000/Tape&Reel