



# 1N4148WS, 1N4448WS, BAV16WS

SURFACE MOUNT SWITCHING DIODES

**Voltage Range 100 Volts**  
**Power 200mWatts**

## Features

- \* Fast switching speed.
- \* Surface mount package Ideally Suited for Automatic insertion
- \* Electrically Identical to Standard JEDEC
- \* High Conductance
- \* Pb free product are available : 99% Sn above can meet Rohs environment substance directive request

## Mechanical Data

Case: SOD-323, Plastic  
Terminals: Solderable per MIL-STD-202G, Method 208  
Approx. Weight: 4.1mg

SOD-323

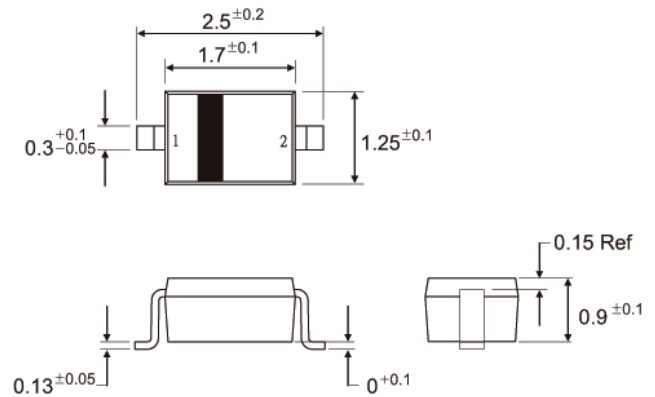

Dimensions in millimeters

## Maximum Ratings and Electrical Characteristics

Ratings at 25°C ambient temperature unless otherwise specified. For capacitive load, derate current by 20%.

PARAMETER	SYMBOL	1N4148WS	1N4448WS	BAV16WS	UNITS
Marking Code		A2	A3	A6	
Reverse Voltage	$V_R$	75			V
Peak Reverse Voltage	$V_{RM}$	100			V
RMS Voltage	$V_{RMS}$	50			V
Maximum DC Blocking Voltage	$V_{DC}$	75			V
Maximum Average Forward Current at $T_a=25^\circ C$	$I_{AV}$	200			mA
Peak Forward Surge Current, 1.0us	$I_{FSM}$	2	4	2	A
Power Dissipation Derate Above 25°C	$P_{TOT}$	200			mW
Maximum Forward Voltage	$V_F$	0.715 @ 0.001A 0.855 @ 0.01A 1.0 / 0.05A 1.25 @ 0.15A	0.72 @ 0.005A 1.0 @ 0.1A	0.855 @ 0.01A	V
Maximum DC Reverse Current at Rated DC Blocking Voltage	$I_R$	0.025 @ 20V 2.5 @ 75V	2.5 @ 75V	1.0 @ 75V	uA
Junction Capacitance( Notes1)	$C_J$	1.5	4.0	20	pF
Maximum Reverse Recovery (Notes2)	$T_{RR}$	4	4	6	ns
Maximum Thermal Resistance	$R_{\theta JA}$	640			°C / W
Operating Junction and Storage Temperature Range	$T_J, T_{STG}$	-55 TO +150			°C

### NOTES:

- 1.CJ at  $V_R=0$ ,  $f=1\text{MHZ}$
- 2.From  $I_F=10\text{mA}$  to  $I_R=1\text{mA}$ ,  $V_R=6\text{Volts}$ ,  $R_L=100\Omega$

[Http://www.upm.com.tw](http://www.upm.com.tw)

E-mail:[upm.tw@msa.hinet.net](mailto:upm.tw@msa.hinet.net)



# 1N4148WS, 1N4448WS, BAV16WS

SURFACE MOUNT SWITCHING DIODES

Voltage Range 100 Volts  
Power 200mWatts

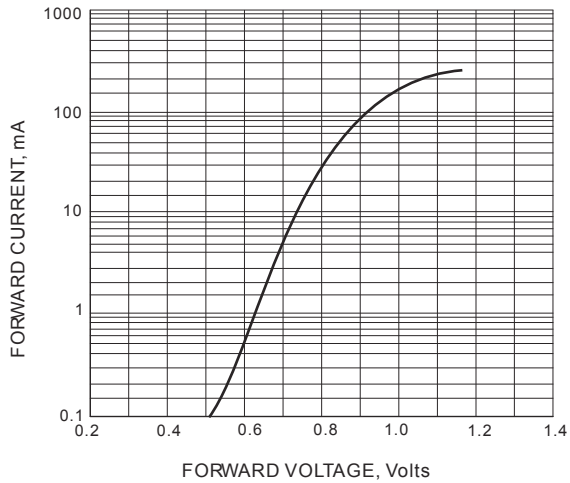

Fig.1 Typical Forward Characteristic

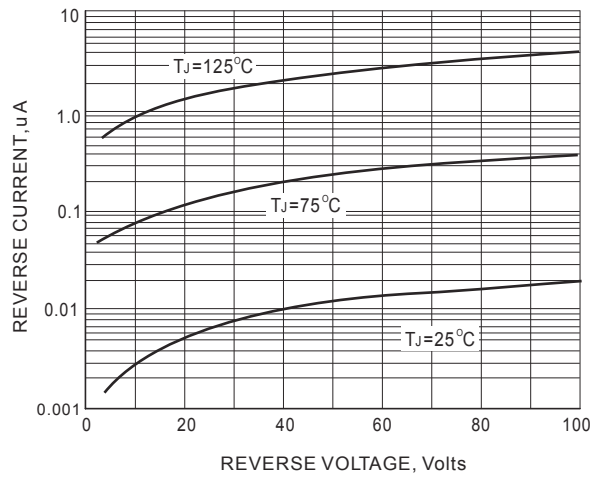

Fig.2 Typical Reverse Characteristics

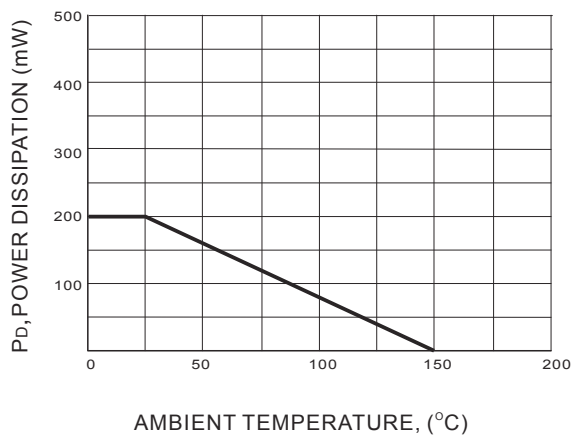

Fig.3 Power Derating Curve