

BC817W ... BC818W SMD General Purpose NPN Transistors SMD Universal-NPN-Transistoren	I_C = 500 mA h_{FE} ~ 180/290/520 T_{jmax} = 150°C	V_{CES} = 30...50 V P_{tot} = 200 mW
---	---	---

Version 2017-02-06

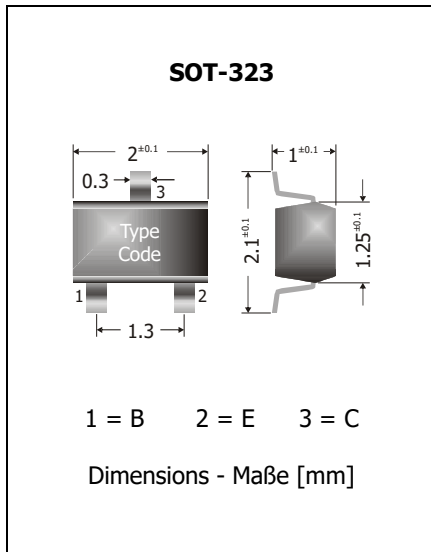

Typical Applications
 Signal processing,
 Switching, Amplification
 Commercial grade ¹⁾

Features
 General Purpose
 Three current gain groups
 Compliant to RoHS, REACH,
 Conflict Minerals ¹⁾

Mechanical Data ¹⁾

Taped and reeled	3000 / 7 ⁿ
Weight approx.	0.01 g
Case material	UL 94V-0
Solder & assembly conditions	260°C/10s
	MSL = 1



Typische Anwendungen
 Signalverarbeitung,
 Schalten, Verstärken
 Standardausführung ¹⁾

Besonderheiten
 Universell anwendbar
 Drei Stromverstärkungsklassen
 Konform zu RoHS, REACH,
 Konfliktmineralien ¹⁾

Mechanische Daten ¹⁾

Gegurtet auf Rolle
Gewicht ca.
Gehäusematerial
Löt- und Einbaubedingungen

Type Code		Recommended complementary PNP transistors Empfohlene komplementäre PNP-Transistoren
BC817-16W = 6A or 6CR BC817-25W = 6B or 6CS BC817-40W = 6C or 6CT	BC818-16W = 6E or 6CR BC818-25W = 6F or 6CS BC818-40W = 6G or 6CT	BC807W, BC808W

Maximum ratings ²⁾

Grenzwerte ²⁾

			BC817W	BC818W
Collector-Emitter-volt. – Kollektor-Emitter-Spannung	E-B short	V _{CES}	50 V	30 V
Collector-Emitter-volt. – Kollektor-Emitter-Spannung	B open	V _{CEO}	45 V	25 V
Emitter-Base-voltage – Emitter-Basis-Spannung	C open	V _{EBO}	5 V	
Power dissipation – Verlustleistung		P _{tot}	200 mW ³⁾	
Collector current – Kollektorstrom (dc)		I _C	500 mA	
Junction temperature – Sperrschichttemperatur		T _j	-55...+150°C	
Storage temperature – Lagerungstemperatur		T _s	-55...+150°C	

1 Please note the [detailed information on our website](#) or at the beginning of the data book
 Bitte beachten Sie die [detaillierten Hinweise auf unserer Internetseite](#) bzw. am Anfang des Datenbuches
 2 T_A = 25°C and per diode, unless otherwise specified – T_A = 25°C und pro Diode, wenn nicht anders angegeben
 3 Mounted on P.C. board with 3 mm² copper pad at each terminal
 Montage auf Leiterplatte mit 3 mm² Kupferbelag (Lötpad) an jedem Anschluss

Characteristics ²⁾
Kennwerte ²⁾

		$T_j = 25^\circ\text{C}$	Min.	Typ.	Max.
DC current gain – Kollektor-Basis-Stromverhältnis ¹⁾					
$V_{CE} = 1\text{ V}, I_C = 100\text{ mA}$	Group -16	h_{FE}	100	–	250
	Group -25		160	–	400
	Group -40		250	–	600
$V_{CE} = 1\text{ V}, I_C = 500\text{ mA}$		h_{FE}	40	–	–
Collector-Emitter saturation voltage – Kollektor-Emitter-Sättigungsspg. ⁴⁾					
$I_C = 500\text{ mA}, I_B = 50\text{ mA}$		V_{CEsat}	–	–	0.7 V
Base-Emitter-voltage – Basis-Emitter-Spannung ¹⁾					
$V_{CE} = 1\text{ V}, I_C = 500\text{ mA}$		V_{BE}	–	–	1.2 V
Collector-Base cutoff current – Kollektor-Basis-Reststrom					
$V_{CB} = 20\text{ V}, (E\text{ open})$		I_{CBO}	–	–	100 nA
Emitter-Base cutoff current – Emitter-Basis-Reststrom					
$V_{EB} = 5\text{ V}, (C\text{ open})$		I_{EBO}	–	–	100 nA
Gain-Bandwidth Product – Transitfrequenz					
$V_{CE} = 5\text{ V}, I_C = 10\text{ mA}, f = 100\text{ MHz}$		f_T	100 MHz	–	–
Collector-Base Capacitance – Kollektor-Basis-Kapazität					
$V_{CB} = 10\text{ V}, I_E = i_e = 0, f = 1\text{ MHz}$		C_{CBO}	–	–	5 pF
Thermal resistance junction to ambient Wärmewiderstand Sperrschicht – Umgebung		R_{thA}	< 625 K/W ²⁾		

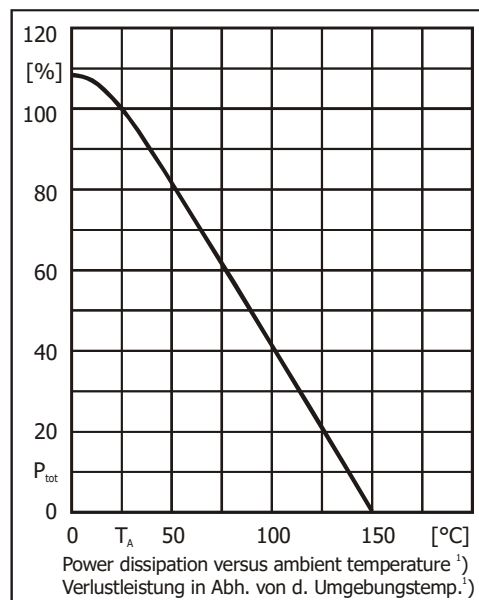

Disclaimer: See data book page 2 or [website](#)
Haftungsausschluss: Siehe Datenbuch Seite 2 oder [Internet](#)

1 Tested with pulses $t_p = 300\ \mu\text{s}$, duty cycle $\leq 2\%$ – Gemessen mit Impulsen $t_p = 300\ \mu\text{s}$, Schaltverhältnis $\leq 2\%$
 2 Mounted on P.C. board with 3 mm^2 copper pad at each terminal
 Montage auf Leiterplatte mit 3 mm^2 Kupferbelag (Lötpad) an jedem Anschluss