

NPN general purpose Transistor

BC847AT/BT/CT

FEATURES

- Ideally suited for automatic insertion.
- For switching and AF amplifier application.



APPLICATIONS

- General purpose switching and amplification.

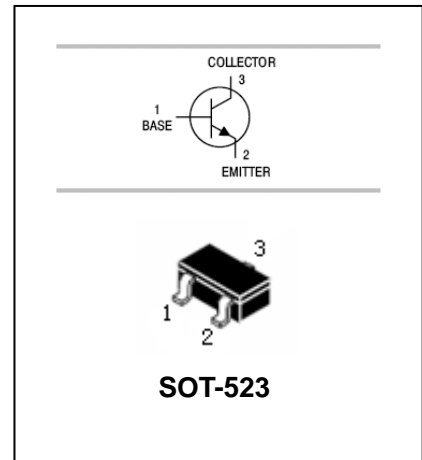

ORDERING INFORMATION

Type No.	Marking	Package Code
BC847AT/BT/CT	1E/1F/1G	SOT-523

MAXIMUM RATING @ Ta=25°C unless otherwise specified

Symbol	Parameter	Value	Units
V _{CBO}	Collector-Base Voltage	50	V
V _{CEO}	Collector-Emitter Voltage	45	V
V _{EBO}	Emitter-Base Voltage	6	V
I _C	Collector Current -Continuous	0.1	A
P _C	Collector Dissipation	150	mW
T _J , T _{stg}	Junction and Storage Temperature	-55 to +150	°C

NPN general purpose Transistor

BC847AT/BT/CT

ELECTRICAL CHARACTERISTICS @ Ta=25°C unless otherwise specified

Parameter	Symbol	Test conditions	MIN	TYP	MAX	UNIT
Collector-base breakdown voltage	$V_{(BR)CBO}$	$I_C=10\mu A, I_E=0$	50			V
Collector-emitter breakdown voltage	$V_{(BR)CEO}$	$I_C=10mA, I_B=0$	45			V
Emitter-base breakdown voltage	$V_{(BR)EBO}$	$I_E=1\mu A, I_C=0$	6			V
Collector cut-off current	I_{CBO}	$V_{CB}=30V, I_E=0$			0.1	μA
DC current gain	BC847AT BC847BT BC847CT h_{FE}	$V_{CE}=5V, I_C=2mA$	110 200 420		220 450 800	
Collector-emitter saturation voltage	$V_{CE(sat)}$	$I_C=10mA, I_B=0.5mA$ $I_C=100mA, I_B=5mA$			0.25 0.6	V
Base-emitter saturation voltage	$V_{BE(sat)}$	$I_C=10mA, I_B=0.5mA$ $I_C=100mA, I_B=5mA$		0.7 0.9		V
Transition frequency	f_T	$V_{CE}=5V,$ $I_C=10mA, f=100KHz$	100			MHz
Collector output capacitance	C_{ob}	$V_{CE}=5V, f=1KHz$			4.5	Pf
Noise figure	NF	$V_{CE}=5V, f=1KHz$ $R_S=2K\Omega, BW=200Hz$			10 4	dB

TYPICAL CHARACTERISTICS @ Ta=25°C unless otherwise specified

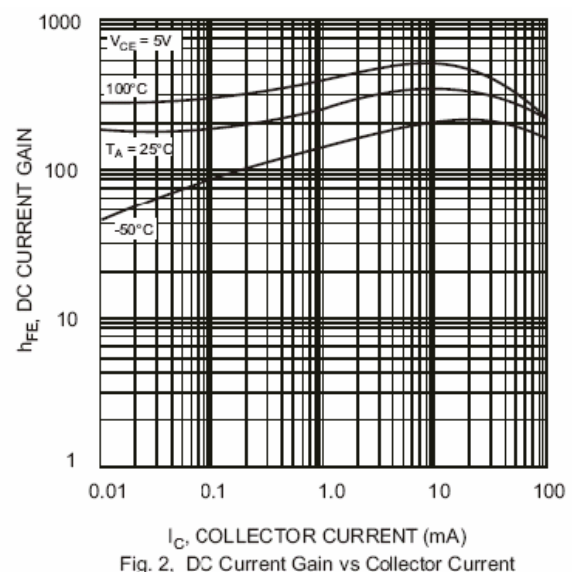
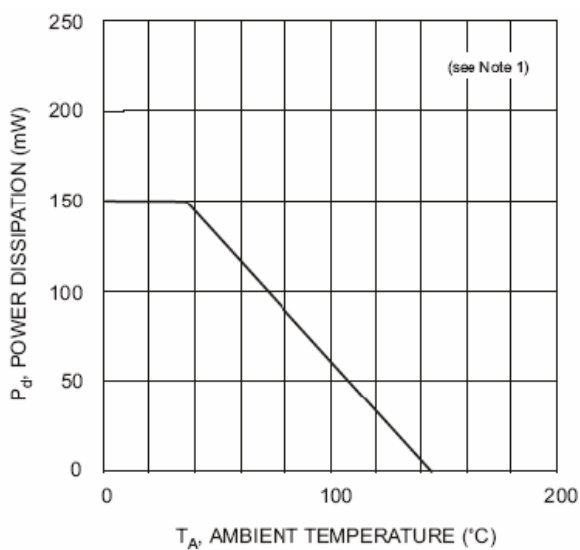

NPN general purpose Transistor

BC847AT/BT/CT

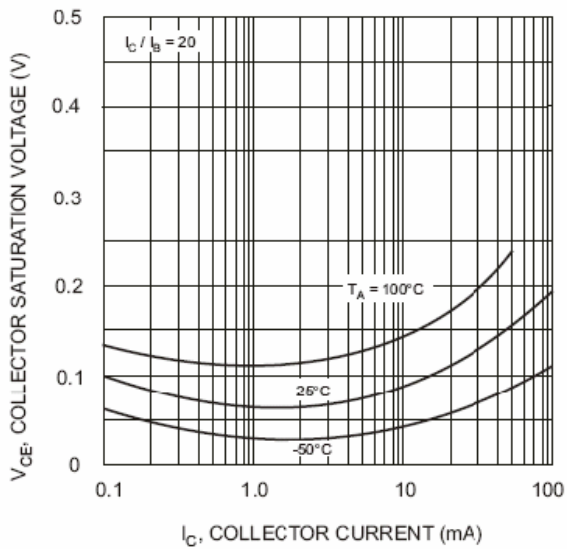

Fig. 3. Collector Saturation Voltage vs Collector Current

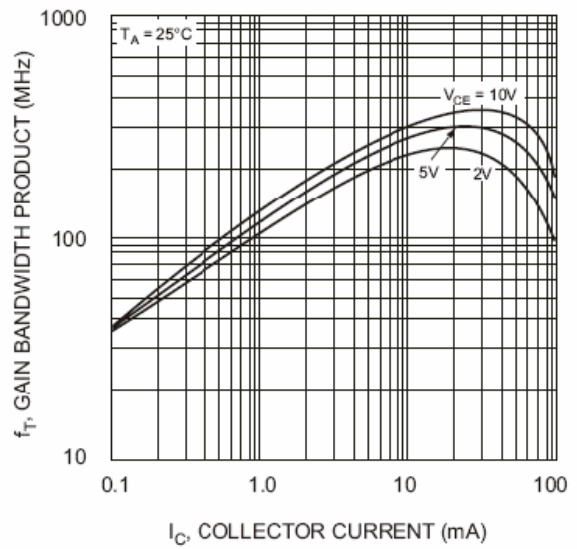
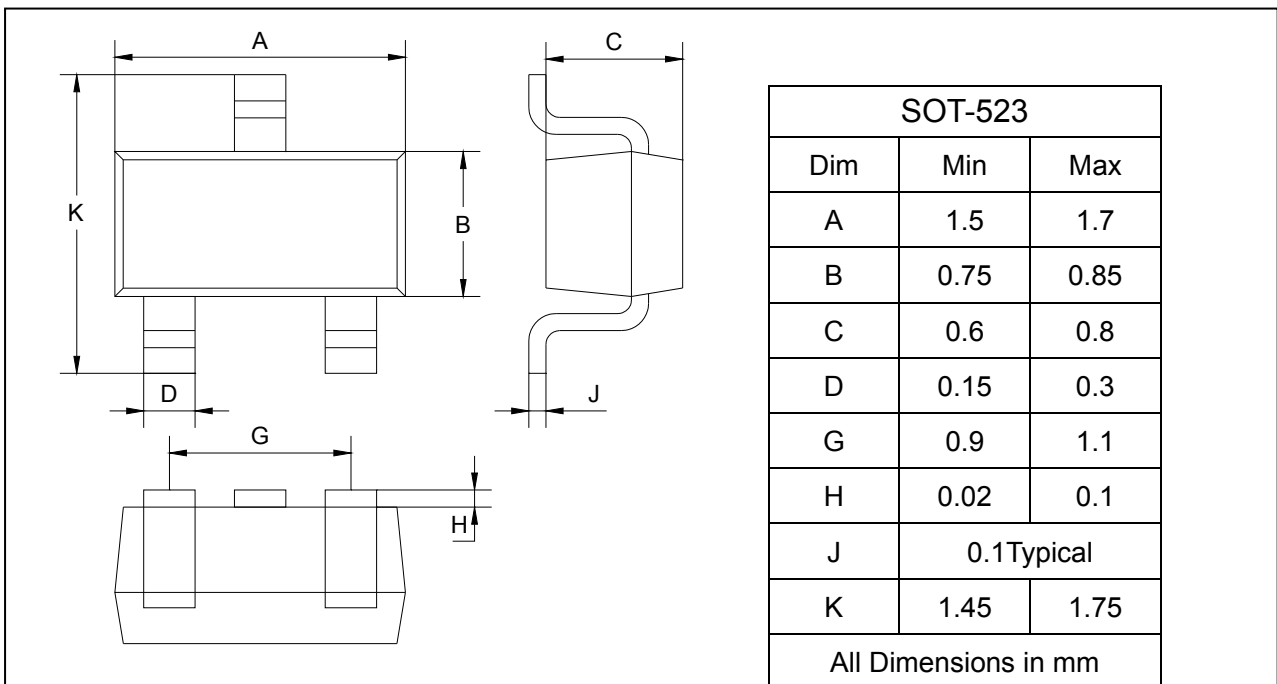

Fig. 4. Gain Bandwidth Product vs Collector Current

PACKAGE OUTLINE

Plastic surface mounted package

SOT-523



NPN general purpose Transistor

BC847AT/BT/CT

SOLDERING FOOTPRINT

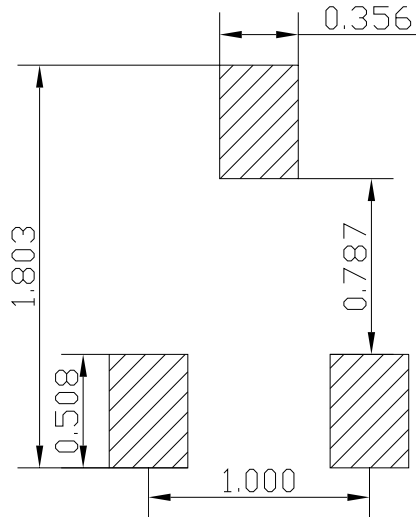

Unit : mm

PACKAGE INFORMATION

Device	Package	Shipping
BC847AT/BT/CT	SOT-523	3000/Tape&Reel