

## Features

- Dual PNP transistors in one single package
- No mutual interference between the transistors

## Absolute Maximum Ratings $(T_A = 25^\circ\text{C}$ unless otherwise noted)

Parameter	Symbol	Value	Unit
Collector- Base Voltage	$V_{CB0}$	-80	V
Collector-Emitter Voltage	$V_{CE0}$	-65	V
Emitter-Base Voltage	$V_{EB0}$	-5	V
Collector Current -Continuous	$I_C$	-0.1	A
Collector Power Dissipation	$P_C$	0.2	W
Thermal Resistance from Junction to Ambient	$R_{SJA}$	625	$^\circ\text{C}/\text{W}$
Junction Temperature	$T_J$	-55 to +150	$^\circ\text{C}$
Storage Temperature	$T_{STG}$	-55 to +150	$^\circ\text{C}$

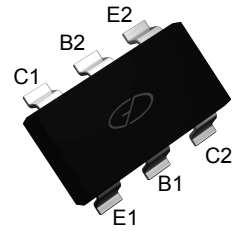

**SOT-363**

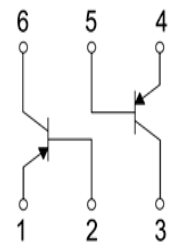

**Schematic Diagram**

## Electrical Characteristics $(T_A = 25^\circ\text{C}$ unless otherwise noted)

Parameter	Symbol	Test Conditions	Min	Typ	Max	Unit
Collector-Base Breakdown Voltage	$V_{(BR)CBO}$	$I_C = -10\mu\text{A}, I_E = 0$	-80	-	-	V
Collector-Emitter Breakdown Voltage	$V_{(BR)CEO}$	$I_C = -10\text{mA}, I_B = 0$	-65	-	-	V
Emitter-Base Breakdown Voltage	$V_{(BR)EBO}$	$I_E = -10\mu\text{A}, I_C = 0$	-5	-	-	V
Collector Cut-off Current	$I_{CBO}$	$V_{CB} = -30\text{V}, I_E = 0$	-	-	-15	nA
Emitter Cut-off Current	$I_{EBO}$	$V_{EB} = -5\text{V}, I_C = 0$	-	-	-100	nA
DC Current Gain	$h_{FE}$	$V_{CE} = -5\text{V}, I_C = -2\text{mA}$	110	-	-	
Collector-emitter Saturation Voltage	$V_{CE(sat)}$	$I_C = -10\text{mA}, I_B = -0.5\text{mA}$	-	-	-0.1	V
		$I_C = -100\text{mA}, I_B = -5\text{mA}^1$	-	-	-0.3	V
Base-emitter Saturation Voltage	$V_{BE(sat)}$	$I_C = -10\text{mA}, I_B = -0.5\text{mA}$	-	0.7	-	V
Output Capacitance	$C_{obo}$	$V_{CB} = -10\text{V}, f = 1\text{MHz}, I_E = 0$	-	-	2.5	pF
Current Gain-Bandwidth	$f_T$	$V_{CE} = -5\text{V}, I_C = -10\text{mA}, f = 100\text{MHz}$	100	-	-	MHz

Note: 1 pulse test: PW $\leq$ 350 $\mu$ S,  $\gamma$ K2%.

**Typical Characteristics Curves**

( $T_A = 25^\circ\text{C}$  unless otherwise noted)

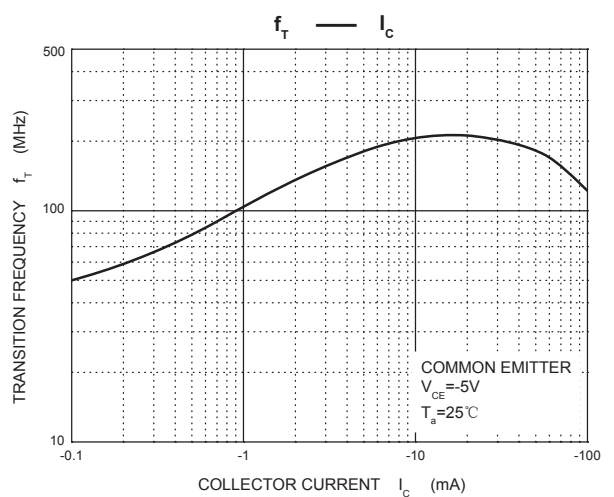
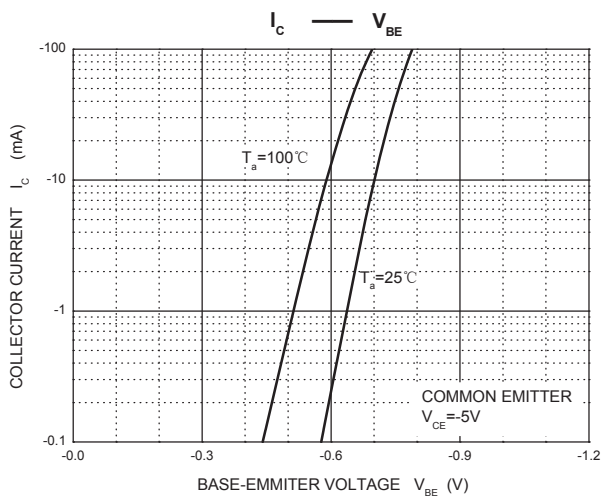
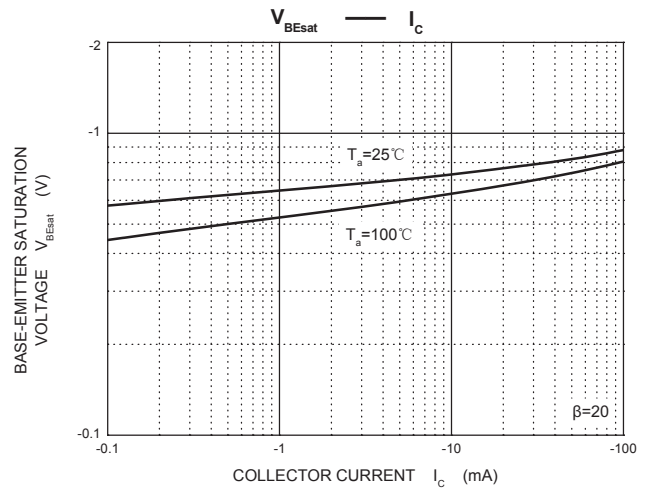
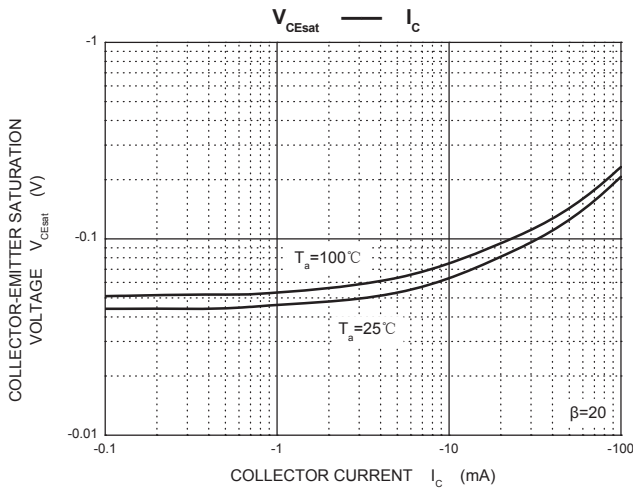
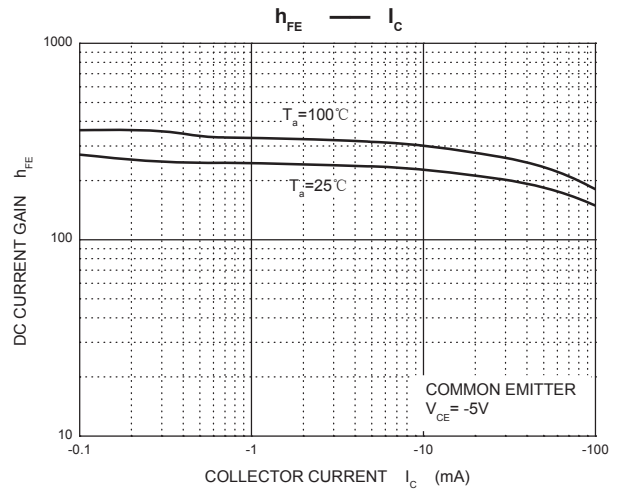
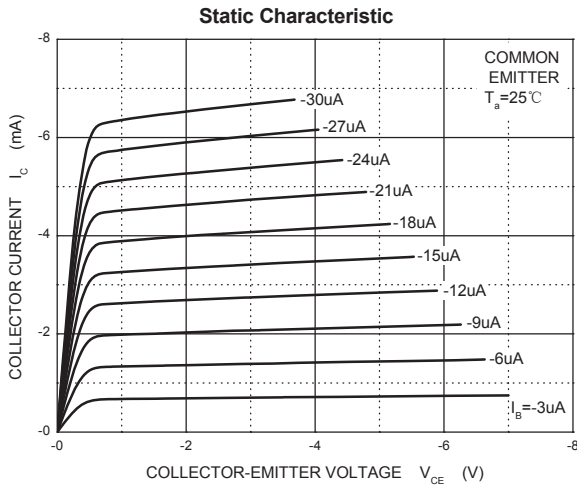

**Typical Characteristics Curves**

( $T_A = 25^\circ\text{C}$  unless otherwise noted)

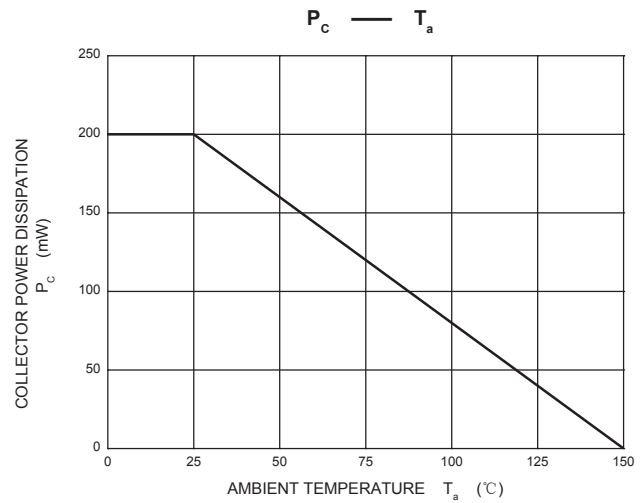
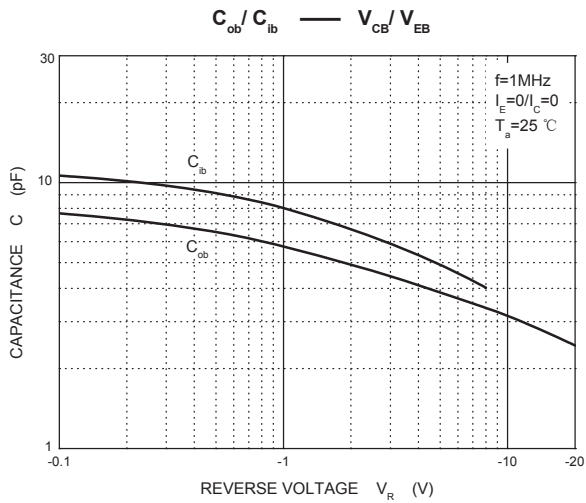

**Package Outline Dimensions**

**SOT-363**

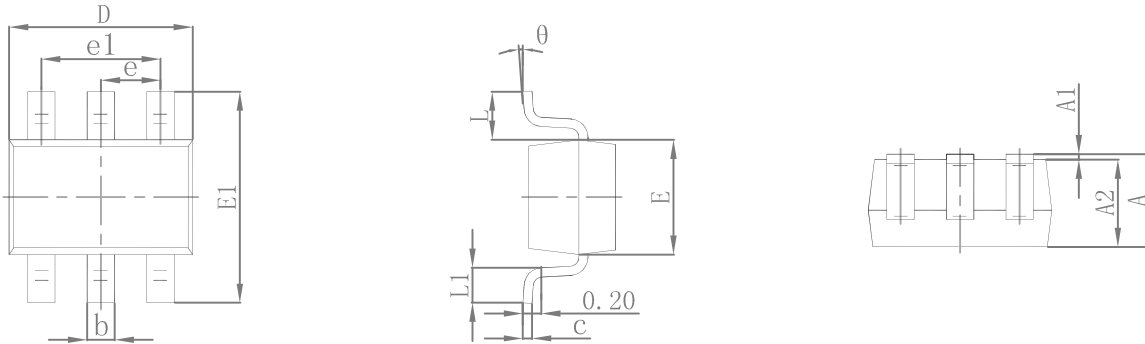

Symbol	Dimensions In Millimeters		Dimensions In Inches	
	Min	Max	Min	Max
A	0.900	1.100	0.035	0.043
A1	0.000	0.100	0.000	0.004
A2	0.900	1.000	0.035	0.039
b	0.150	0.350	0.006	0.014
c	0.100	0.150	0.004	0.006
D	2.000	2.200	0.079	0.087
E	1.150	1.350	0.045	0.053
E1	2.150	2.400	0.085	0.094
e	0.650 TYP		0.026 TYP	
e1	1.200	1.400	0.047	0.055
L	0.525 REF		0.021 REF	
L1	0.260	0.460	0.010	0.018
theta	0°	8°	0°	8°

**Suggested Pad Layout**

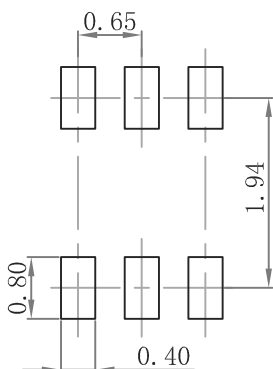

**Note:**

1. Controlling dimension: in millimeters.
2. General tolerance:  $\pm 0.05\text{mm}$ .
3. The pad layout is for reference purposes only.