

SOT89 Plastic-Encapsulate Transistors

BC868 TRANSISTOR (NPN)

FEATURES

- High current
- Low voltage

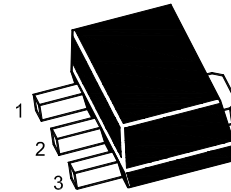

1.Base 2.Collector 3.Emitter
SOT-89 Plastic Package

MAXIMUM RATINGS (T_a=25°C unless otherwise noted)

Symbol	Parameter	Value	Unit
V _{CB0}	Collector-Base Voltage	32	V
V _{CE0}	Collector-Emitter Voltage	20	V
V _{EB0}	Emitter-Base Voltage	5	V
I _c	Collector Current -Continuous	1	A
P _c	Collector Power Dissipation	500	mW
T _J	Junction Temperature	150	°C
T _{stg}	Storage Temperature	-55~150	°C

ELECTRICAL CHARACTERISTICS (T_a=25°C unless otherwise specified)

Parameter	Symbol	Test conditions	Min	Typ	Max	Unit
Collector-base breakdown voltage	V _{(BR)CBO}	I _C =100μA, I _E =0	32			V
Collector-emitter breakdown voltage	V _{(BR)CEO}	I _C =1mA, I _B =0	20			V
Emitter-base breakdown voltage	V _{(BR)EBO}	I _E =100μA, I _C =0	5			V
Collector cut-off current	I _{CBO}	V _{CB} =25V, I _E =0			0.1	μA
Emitter cut-off current	I _{EBO}	V _{EB} =5V, I _C =0			0.1	μA
DC current gain	h _{FE(1)}	V _{CE} =1V, I _C =500mA	85		375	
	h _{FE(2)}	V _{CE} =1V, I _C =1A	60			
	h _{FE(3)}	V _{CE} =10V, I _C =5mA	50			
Collector-emitter saturation voltage	V _{CE(sat)}	I _C =1A, I _B =100mA			0.5	V
Base-emitter voltage	V _{BE1}	V _{CE} =10V, I _C =5mA		0.62		V
	V _{BE2}	V _{CE} =1V, I _C =1A			1	V
Transition frequency	f _T	V _{CE} =5V, I _C =10mA, f=100MHz	40			MHz

CLASSIFICATION OF h_{FE(1)}

Rank	BC868-10	BC868-16	BC868-25
Range	85-160	100-250	160-375
Marking	CBC	CCC	CDC

BC868

SOT-89 PACKAGE OUTLINE

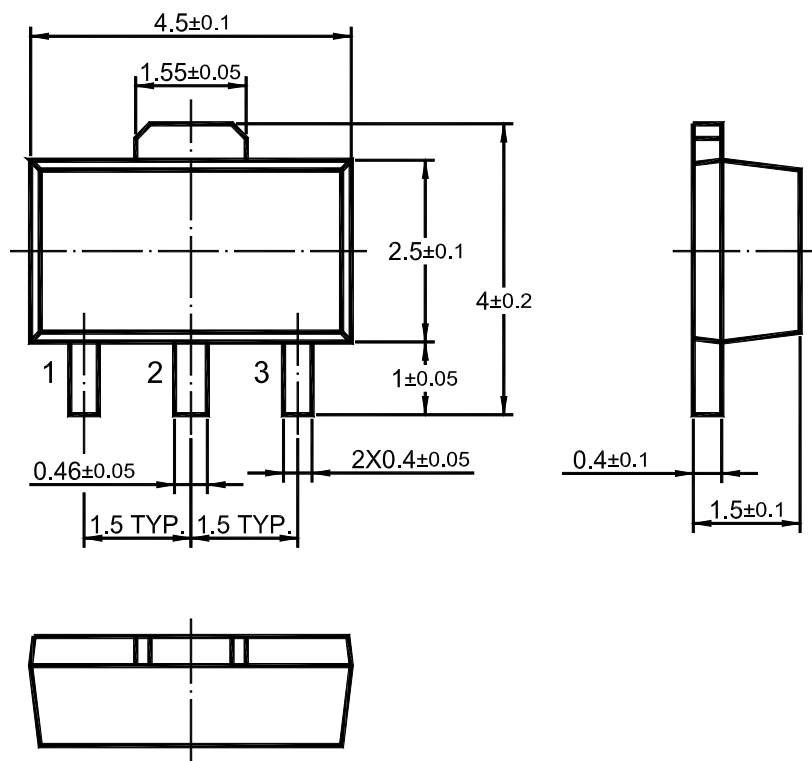

Dimensions in mm