

Single Chip IEEE 802.11 a/b/g/n MAC/Baseband/Radio with Integrated Bluetooth 4.0 + HS and FM Receiver

GENERAL DESCRIPTION

The Broadcom® BCM4334X single-chip device provides the highest level of integration for a mobile or handheld wireless system, with integrated IEEE 802.11 a/b/g and single-stream IEEE 802.11n MAC/baseband/radio, Bluetooth 4.0 + HS, and FM radio receiver. It is designed to be used with external 2.4 GHz and 5 GHz front-end modules, which include power amplifiers, low-noise amplifiers, and T/R switches.

Using advanced design techniques and process technology to reduce active and idle power, the BCM4334X is designed to address the needs of highly mobile devices that require minimal power consumption and compact size. It includes a power management unit which simplifies the system power topology and allows for operation directly from a mobile platform battery while maximizing battery life.

FEATURES

The BCM4334X implements the highly sophisticated Enhanced Collaborative Coexistence algorithms and hardware mechanisms, allowing for an extremely collaborative Bluetooth coexistence scheme along with coexistence support for external radios (such as cellular and LTE, GPS, WiMAX, and Ultra-Wideband) and a single shared 2.4 GHz antenna for Bluetooth and WLAN. As a result, enhanced overall quality for simultaneous voice, video, and data transmission on a handheld system is achieved.

For the WLAN section, two alternative host interface options are included: an SDIO v2.0 interface (including gSPI) and a High-Speed Inter-Chip (HSIC) interface (a USB 2.0 derivative for short-distance on-board connections). An independent, high-speed UART is provided for the Bluetooth host interface.

Figure 1: Functional Block Diagram

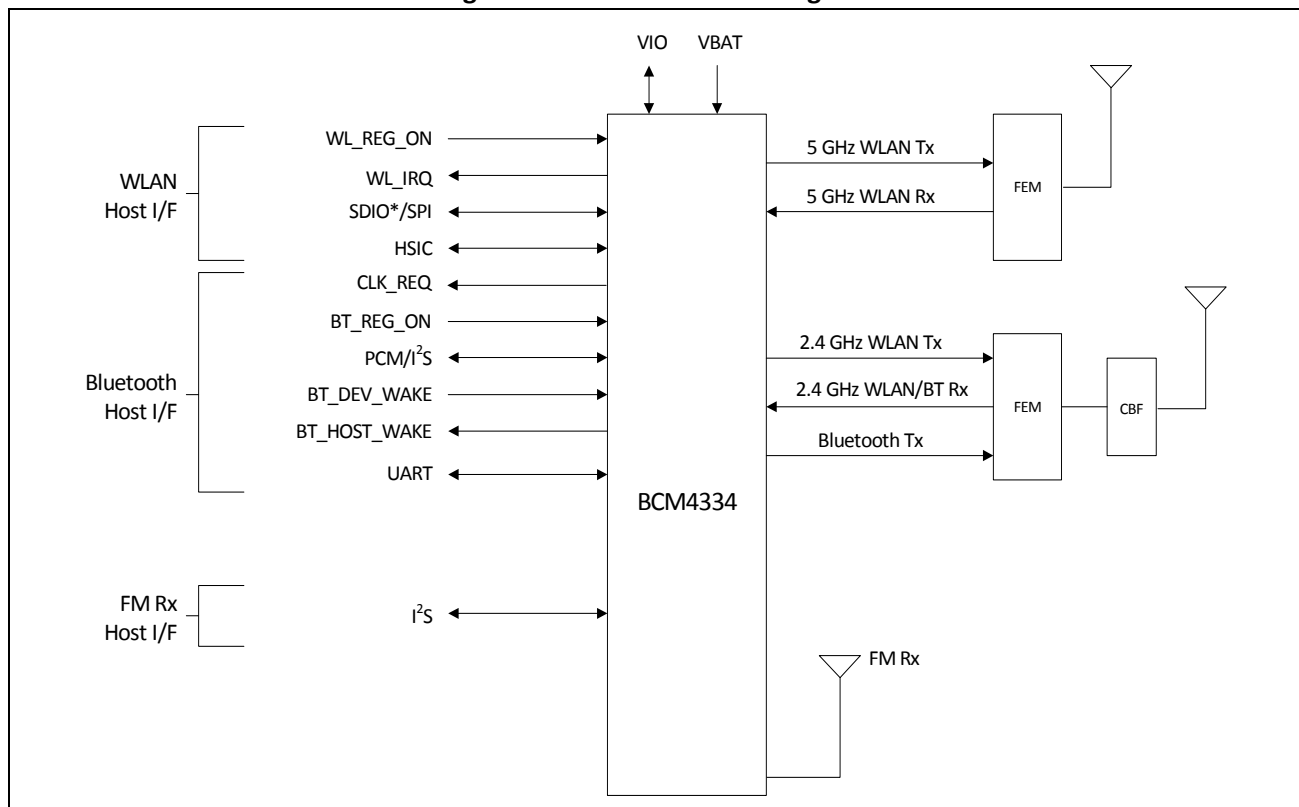

Not Recommended for New Designs

FEATURES**IEEE 802.11x Key Features**

- Single-band 2.4 GHz IEEE 802.11 b/g/n or dual-band 2.4 GHz and 5 GHz IEEE 802.11 a/b/g/n
- Single-stream IEEE 802.11n support for 20 MHz and 40 MHz channels provides PHY layer rates up to 150 Mbps for typical upper-layer throughput in excess of 90 Mbps.
- Supports the IEEE 802.11n STBC (space-time block coding) and LDPC (low-density parity check) options for improved range and power efficiency.
- Up to 11 RF control signals are available to support external PAs and LNAs.
- Supports a single 2.4 GHz antenna shared between WLAN and Bluetooth.
- Shared Bluetooth and WLAN receive signal path eliminates the need for an external power splitter while maintaining excellent sensitivity for both Bluetooth and WLAN.
- Internal fractional nPLL allows support for a wide range of reference clock frequencies
- Supports IEEE 802.15.2 external coexistence interface to optimize bandwidth utilization with other co-located wireless technologies such as GPS, WiMAX, or UWB
- Supports standard SDIO v2.0 and gSPI (48 MHz) host interfaces.
- Alternative host interface supports HSIC v1.0 (short-distance USB device)
- Integrated ARM® Cortex-M3™ processor and on-chip memory for complete WLAN subsystem functionality, minimizing the need to wake up the applications processor for standard WLAN functions. This allows for further minimization of power consumption, while maintaining the ability to field upgrade with future features. On-chip memory includes 512 KB SRAM and 640 KB ROM.
- OneDriver™ software architecture for easy migration from existing embedded WLAN and Bluetooth devices as well as future devices.

FEATURES**Bluetooth and FM Key Features**

- Complies with Bluetooth Core Specification Version 4.0 + HS with provisions for supporting future specifications.
- Bluetooth Class 1 or Class 2 transmitter operation
- Supports extended Synchronous Connections (eSCO), for enhanced voice quality by allowing for retransmission of dropped packets.
- Adaptive Frequency Hopping (AFH) for reducing radio frequency interference
- Interface support — Host Controller Interface (HCI) using a high-speed UART interface and PCM for audio data
- The FM unit supports HCI for communication.
- Low power consumption improves battery life of handheld devices.
- FM receiver: 65 MHz to 108 MHz FM bands; supports the European Radio Data Systems (RDS) and the North American Radio Broadcast Data System (RBDS) standards
- Supports multiple simultaneous Advanced Audio Distribution Profiles (A2DP) for stereo sound.
- Automatic frequency detection for standard crystal and TCXO values

General Features

- Supports battery voltage range from 2.3V to 4.8V supplies with internal switching regulator.
- Programmable dynamic power management
- 3072-bit One-Time Programmable (OTP) memory for storing board parameters
- 8 GPIOs on the WLBGA package, 16 GPIOs on the WLCSP package
- Package options:
 - 109 ball WLBGA (4.08 mm × 4.48 mm, 0.4 mm pitch)
 - 208 bump WLCSP (4.08 mm × 4.48 mm, 0.2 mm pitch)
- Security:
 - WPA™ and WPA2™ (Personal) support for powerful encryption and authentication
 - AES and TKIP in hardware for faster data encryption and IEEE 802.11i compatibility
 - Reference WLAN subsystem provides Cisco® Compatible Extensions (CCX, CCX 2.0, CCX 3.0, CCX 4.0, CCX 5.0)
 - Reference WLAN subsystem provides Wi-Fi Protected Setup (WPS)
- Worldwide regulatory support: Global products supported with worldwide homologated design

Revision History

Revision	Date	Change Description
002-14947 Rev *I	09/20/16	Parts in this datasheets are not recommended for new designs
4334-DS107-R	02/27/13	Updated: <ul style="list-style-type: none"> Table 26: "Absolute Maximum Ratings," on page 122. Table 37: "WLAN 2.4 GHz Transmitter Performance Specifications," on page 144.
4334-DS106-R	09/27/12	Updated: <ul style="list-style-type: none"> SDIO interface support changed to v2.0. Corrected the structure of GPIO signal names (for example, BT_GPIO1 changed to BT_GPIO_1; GPIO_0 changed to WL_GPIO_0; etc.). Table 2: "Crystal Oscillator and External Clock – Requirements and Performance," on page 35. Figure 18: "I2S Transmitter Timing," on page 65. Figure 19: "I2S Receiver Timing," on page 65. "SDIO v2.0" on page 74. Figure 32: "WLAN Boot-Up Sequence," on page 84. Figure 34: "WLAN MAC Architecture," on page 87: removed WAPI. Table 20: "WLBGA and WLCSP Signal Descriptions," on page 104. Table 21: "WLAN GPIO Functions and Strapping Options (Advance Information)," on page 114. Table 25: "I/O States," on page 120, Table 28: "ESD Specifications," on page 125, Table 29: "Recommended Operating Conditions and DC Characteristics," on page 126, Table 30: "Bluetooth Receiver RF Specifications," on page 130, Table 34: "FM Receiver Specifications," on page 136, Table 37: "WLAN 2.4 GHz Transmitter Performance Specifications," on page 146, Table 38: "WLAN 5 GHz Receiver Performance Specifications," on page 147, Table 39: "WLAN 5 GHz Transmitter Performance Specifications," on page 150, Table 41: "Core Buck Switching Regulator (CBLUCK) Specifications," on page 152, and Table 47: "Typical WLAN Power Consumption," on page 159: Updated footnote b. "Bluetooth, BLE, and FM Current Consumption" on page 161. Figure 46: "WLAN = OFF, Bluetooth = OFF," on page 169. Figure 48: "WLAN = OFF, Bluetooth = ON," on page 170. Removed: <ul style="list-style-type: none"> "Multiplexed Bluetooth and FM over PCM" on page 51.
4334-DS105-R	02/21/12	Updated: <ul style="list-style-type: none"> Table 2: "Crystal Oscillator and External Clock – Requirements and Performance," on page 35 Added footnote f: The crystal should be capable of handling a 200uW drive level from the BCM4334. Figure 39: "208-WLCSP Bump Map (Bottom View)," on page 97. Minor corrections to pin names. Removed: <ul style="list-style-type: none"> AAC+ decoder designation in document.

Not Recommended for New Designs

Revision	Date	Change Description
4334-DS104-R	1/18/12	<p>Updated:</p> <ul style="list-style-type: none"> • The device suffix throughout the document to B series from B0. • The cover page General Description, Features, and Figure 1: “Functional Block Diagram,” on page 1. • Battery voltage range from 2.3V to 5.5V to 2.3V to 4.8V throughout. • Figure 2: “BCM4334 Block Diagram,” on page 19 by changing USB 3.0 Device block to USB 2.0 Device. • “Features” on page 20 and “Standards Compliance” on page 21. • “Mobile Phone Usage Model” on page 22. • “Power Supply Topology” on page 24. • Figure 4: “Typical Power Topology,” on page 25. • Table 2: “Crystal Oscillator and External Clock – Requirements and Performance,” on page 31. • “External 32.768 kHz Low-Power Oscillator” on page 33. • Second paragraph of Section 4: “Bluetooth + FM Subsystem Overview,” on page 34. • “PCM Interface Timing” on page 51. • “FM Radio” on page 62. • “GPIO Interface” and “External Coexistence Interface” on page 69. • “SDIO v3.0” on page 70. • “PHY Features” on page 85. • Introduction of Section 13: “WLAN Radio Subsystem” and “Calibration” on page 87. • Figure 39: “109-WLBGA Ball Map (Bottom View),” on page 89. • Table 19: “WLCSP 208 – Bump Coordinates,” on page 91, Table 20: “WLBGA and WLCSP Signal Descriptions,” on page 98, Table 21: “WLAN GPIO Functions and Strapping Options (Advance Information),” on page 106, Table 25: “I/O States,” on page 112, Table 26: “Absolute Maximum Ratings,” on page 115, and Table 29: “Recommended Operating Conditions and DC Characteristics,” on page 117. • Section 16: “Bluetooth RF Specifications,” on page 119. • Table 34: “FM Receiver Specifications,” on page 125. • “Bluetooth, BLE, and FM Current Consumption” on page 150. • Table 36: “WLAN 2.4 GHz Receiver Performance Specifications,” on page 132, Table 37: “WLAN 2.4 GHz Transmitter Performance Specifications,” on page 135, and Table 38: “WLAN 5 GHz Receiver Performance Specifications,” on page 136.

Not Recommended for New Designs

Revision	Date	Change Description
4334-DS104-R	1/18/12	<p>Updated (continued):</p> <ul style="list-style-type: none"> • Table 39: “WLAN 5 GHz Transmitter Performance Specifications,” on page 139. • Table 41: “Core Buck Switching Regulator (CBUCK) Specifications,” on page 141. • Section 19: “Internal Regulator Electrical Specifications,” on page 141. • Table 43: “LDO2P5 Specifications,” on page 144. • Table 45: “CLDO Specifications,” on page 146. • Table 46: “LNLDO Specifications,” on page 147. • Table 47: “Typical WLAN Power Consumption,” on page 148. • “Sequencing of Reset and Regulator Control Signals” on page 157. • Figure 51: “WLBGA Keep-Out Areas for PCB Layout — Bottom View,” on page 162 • Figure 53: “WLCSP Keep-Out Areas for PCB Layout — Bottom View with Bumps Facing Up,” on page 164. <p>Added:</p> <ul style="list-style-type: none"> • “SPI Interface and Transport Selection” on page 48. • Figure 26: “SDIO Pull-Up Requirements,” on page 71. <p>Removed:</p> <ul style="list-style-type: none"> • Table 21: WLAN GPIO Functions and Strapping Options.
4334-DS103-R	9/20/11	<p>Updated:</p> <ul style="list-style-type: none"> • “Ordering Information” on page 156.

Revision	Date	Change Description
4334-DS102-R	6/20/11	<p>Updated:</p> <ul style="list-style-type: none"> • “General Features” on page 2 • “Crystal Interface and Clock Generation” on page 26Section 14: Pinout and Signal Descriptions. NOTE: Changes include a new bump map for the 208-bump WLCSP package that applies to the 4334B0 onwards (not to the A0 version): • Figure 38: “109-WLBGA Ball Map (Bottom View),” on page 87 • Figure 39: “208-WLCSP Bump Map (Bottom View),” on page 88 • Table 17: “WLCSP 208 – Bump Coordinates,” on page 89 • Table 18: “WLBGA and WLCSP Signal Descriptions,” on page 95 • Table 19: “WLAN GPIO Functions and Strapping Options (Advance Information),” on page 102 • Table 20: “OTP Select,” on page 105 • Section 15: DC Characteristics: Table 25: “Absolute Maximum Ratings,” on page 111 • Section 16: Bluetooth RF Specifications: • Table 29: “Bluetooth Receiver RF Specifications,” on page 116 • Table 30: “Bluetooth Transmitter RF Specifications,” on page 119 • Table 31: “Local Oscillator Performance,” on page 120 • Section 21: Interface Timing and AC Characteristics: Table 48: “gSPI Timing Parameters,” on page 145 • Section 24: Mechanical Information: • Figure 49: “109-Ball WLBGA Package Mechanical Information,” on page 152 • Figure 51: “208-Bump WLCSP Package Mechanical Information,” on page 154 • Section 25: “Ordering Information,” on page 156

Revision	Date	Change Description
4334-DS101-R	01/26/11	<p>Updated:</p> <ul style="list-style-type: none"> • Figure 1: “Functional Block Diagram,” on page 1 • Figure 3: “Mobile Phone Block System Diagram,” on page 22 • “Crystal Interface and Clock Generation” on page 28 • Figure 6: “Recommended Circuit to Use with an External Dedicated TCXO,” on page 29 • Figure 7: “Recommended Circuit to Use with an External Shared TCXO,” on page 29 • Figure 8: “Startup Signaling Sequence,” on page 41 • “Bluetooth 4.0 Features” on page 38 • Table 17: “WLCSP 204-Bump Coordinates,” on page 90 • Figure 38: “109-WLBGA Ball Map (Bottom View),” on page 88 • Table 18: “WLBGA and WLCSP Signal Descriptions,” on page 96 • Table 28: “Recommended Operating Conditions and DC Characteristics,” on page 114 • Table 30: “Bluetooth Transmitter RF Specifications,” on page 119 • Table 31: “Local Oscillator Performance,” on page 120 • Table 43: “WLAN Power Consumption (Ivbat + Ivio),” on page 140 • Figure 47: “WLAN = ON, Bluetooth = OFF,” on page 150 • Table 50: “Package Thermal Characteristics,” on page 151 <p>Added:</p> <ul style="list-style-type: none"> • “Bluetooth Low Energy” on page 38 • Figure 50: “WLBGA Keep-out Areas for PCB Layout — Top View,” on page 153
4334-DS100-R	12/07/10	Initial release

Not Recommended for New Designs

Table of Contents

About This Document..... 18

 Purpose and Audience 18

 Acronyms and Abbreviations 18

 Document Conventions 18

 References 19

Technical Support..... 19

Section 1: BCM4334 Overview..... **20**

Overview 20

Features 21

Standards Compliance..... 22

Mobile Phone Usage Model..... 23

Section 2: Power Supplies and Power Management **25**

Power Supply Topology..... 25

 BCM4334 PMU Features..... 25

WLAN Power Management..... 28

PMU Sequencing 29

Power-off Shutdown 30

Power-Up/Power-Down/Reset Circuits..... 30

Section 3: Frequency References **31**

Crystal Interface and Clock Generation 31

TCXO 32

Frequency Selection 34

External 32.768 kHz Low-Power Oscillator 35

Section 4: Bluetooth + FM Subsystem Overview **36**

Features 36

Bluetooth Radio..... 38

 Transmit 38

 Digital Modulator 38

 Digital Demodulator and Bit Synchronizer..... 38

 Power Amplifier 38

 Receiver 39

 Digital Demodulator and Bit Synchronizer..... 39

 Receiver Signal Strength Indicator 39

Not Recommended for New Designs

Local Oscillator Generation..... 39

Calibration..... 39

Section 5: Bluetooth Baseband Core..... 40

Bluetooth 4.0 Features..... 40

Bluetooth Low Energy 40

Link Control Layer 41

Test Mode Support..... 41

Bluetooth Power Management Unit 42

 RF Power Management 42

 Host Controller Power Management..... 42

 BBC Power Management 44

 FM Power Management 44

 Wideband Speech 44

 Packet Loss Concealment 45

 Audio Rate-Matching Algorithms 45

 Codec Encoding..... 45

 Multiple Simultaneous A2DP Audio Stream 46

 FM Over Bluetooth 46

 Burst Buffer Operation 46

Adaptive Frequency Hopping..... 46

Advanced Bluetooth/WLAN Coexistence 47

Fast Connection (Interlaced Page and Inquiry Scans) 47

Section 6: Music and Audio 48

 MP3 Encoder..... 48

 MP3 Decoder 48

 AAC Decoder..... 48

Section 7: Microprocessor and Memory Unit for Bluetooth..... 49

 RAM, ROM, and Patch Memory..... 49

 Reset 49

Section 8: Bluetooth Peripheral Transport Unit 50

SPI Interface and Transport Selection 50

PCM Interface 51

 Slot Mapping..... 51

 Frame Synchronization 51

 Data Formatting..... 51

Not Recommended for New Designs

Wideband Speech Support 52

Burst PCM Mode 52

PCM Interface Timing 53

 Short Frame Sync, Master Mode 53

 Short Frame Sync, Slave Mode 54

 Long Frame Sync, Master Mode 55

 Long Frame Sync, Slave Mode 56

 Short Frame Sync, Burst Mode 57

 Long Frame Sync, Burst Mode 58

UART Interface 59

I²S Interface 61

 I²S Timing 61

Section 9: FM Receiver Subsystem 64

FM Radio 64

Digital FM Audio Interfaces 64

FM Over Bluetooth 64

eSCO 64

Wide Band Speech Link 65

A2DP 65

Autotune and Search Algorithms 65

Audio Features 66

On-Chip MP3 Encoding 68

RDS/RBDS 69

Section 10: WLAN Global Functions 70

WLAN CPU and Memory Subsystem 70

One-Time Programmable Memory 70

GPIO Interface 71

(4334/Apple/MCS)External Coexistence Interface 71

UART Interface 71

JTAG Interface 71

Section 11: WLAN Host Interfaces 72

SDIO v2.0 72

 SDIO Pin Descriptions 72

Generic SPI Mode 75

 SPI Protocol 76

Not Recommended for New Designs

Command Structure	77
Write	77
Write/Read	77
Read	77
Status	78
gSPI Host-Device Handshake	80
Boot-Up Sequence	80
HSIC Interface	83
Section 12: Wireless LAN MAC and PHY	84
MAC Features	84
MAC Description	84
PSM	85
WEP	86
TXE	86
RXE	86
IFS	87
TSF	87
NAV	87
MAC-PHY Interface	87
WLAN PHY Description	88
PHY Features	88
Section 13: WLAN Radio Subsystem	90
Receiver Path	90
Transmit Path	90
Calibration	90
Section 14: Pinout and Signal Descriptions	92
Signal Assignments	92
Signal Descriptions	102
WLAN GPIO Signals and Strapping Options	112
Multiplexed Bluetooth GPIO Signals	116
I/O States	118
Section 15: DC Characteristics	122
Absolute Maximum Ratings	122
Environmental Ratings	123
Electrostatic Discharge Specifications	123

Not Recommended for New Designs

Recommended Operating Conditions and DC Characteristics	124
Section 16: Bluetooth RF Specifications	126
Section 17: FM Receiver Specifications	134
Section 18: WLAN RF Specifications.....	139
Introduction	139
2.4 GHz Band General RF Specifications	140
WLAN 2.4 GHz Receiver Performance Specifications	141
WLAN 2.4 GHz Transmitter Performance Specifications.....	144
WLAN 5 GHz Receiver Performance Specifications	145
WLAN 5 GHz Transmitter Performance Specifications.....	148
General Spurious Emissions Specifications.....	149
Section 19: Internal Regulator Electrical Specifications.....	151
Core Buck Switching Regulator	151
3.3V LDO (LDO3P3)	153
2.5V LDO (LDO2P5)	154
HSICDVDD LDO	155
CLDO	156
LNLDO	157
Section 20: System Power Consumption.....	158
WLAN Current Consumption.....	158
Bluetooth, BLE, and FM Current Consumption	160
Section 21: Interface Timing and AC Characteristics	161
SDIO/gSPI Timing.....	161
SDIO Default Mode Timing	161
SDIO High-Speed Mode Timing.....	163
gSPI Signal Timing	164
HSIC Interface Specifications.....	165
JTAG Timing	166
Section 22: Power-Up Sequence and Timing.....	167
Bluetooth Random Bit Generator	167
Sequencing of Reset and Regulator Control Signals.....	167
Description of Control Signals.....	168
Control Signal Timing Diagrams	168

Section 23: Package Information	171
Package Thermal Characteristics	171
Junction Temperature Estimation and Ψ_{JT} Versus Θ_{JC}	171
Environmental Characteristics	171
Section 24: Mechanical Information	172
Section 25: Ordering Information	176

Not Recommended for New Designs

List of Figures

Figure 1: Functional Block Diagram	1
Figure 2: BCM4334 Block Diagram	20
Figure 3: Mobile Phone System Block Diagram.....	24
Figure 4: Typical Power Topology.....	27
Figure 5: Recommended Oscillator Configuration	31
Figure 6: Recommended Circuit to Use with an External Dedicated TCXO.....	32
Figure 7: Recommended Circuit to Use with an External Shared TCXO.....	32
Figure 8: Startup Signaling Sequence	43
Figure 9: CVSD Decoder Output Waveform Without PLC	45
Figure 10: CVSD Decoder Output Waveform After Applying PLC	45
Figure 11: PCM Timing Diagram (Short Frame Sync, Master Mode).....	53
Figure 12: PCM Timing Diagram (Short Frame Sync, Slave Mode).....	54
Figure 13: PCM Timing Diagram (Long Frame Sync, Master Mode).....	55
Figure 14: PCM Timing Diagram (Long Frame Sync, Slave Mode).....	56
Figure 15: PCM Burst Mode Timing (Receive Only, Short Frame Sync)	57
Figure 16: PCM Burst Mode Timing (Receive Only, Long Frame Sync)	58
Figure 17: UART Timing	60
Figure 18: I ² S Transmitter Timing.....	63
Figure 19: I ² S Receiver Timing.....	63
Figure 20: Example Blend/Switch Usage	66
Figure 21: Example Blend/Switch Separation	67
Figure 22: Example Soft Mute Characteristic	68
Figure 23: Signal Connections to SDIO Host (SD 4-Bit Mode)	73
Figure 24: Signal Connections to SDIO Host (SD 1-Bit Mode)	74
Figure 25: SDIO Pull-Up Requirements.....	74
Figure 26: Signal Connections to SDIO Host (gSPI Mode)	75
Figure 27: gSPI Write Protocol	76
Figure 28: gSPI Read Protocol	76
Figure 29: gSPI Command Structure.....	77
Figure 30: gSPI Signal Timing Without Status (32-bit big endian shown).....	78
Figure 31: gSPI Signal Timing with Status (Response Delay = 0) (32-bit big endian shown)	79
Figure 32: WLAN Boot-Up Sequence.....	82
Figure 33: HSIC Device Block Diagram.....	83
Figure 34: WLAN MAC Architecture	85
Figure 35: WLAN PHY Block Diagram	89

Figure 36: STBC Implementation in the Receive Path	89
Figure 37: Radio Functional Block Diagram	91
Figure 38: 109-WLBGA Ball Map (Bottom View)	92
Figure 39: 208-WLCSP Bump Map (Bottom View)	94
Figure 40: RF Port Location for Bluetooth Testing	127
Figure 41: Port Locations	140
Figure 42: SDIO Bus Timing (Default Mode)	161
Figure 43: SDIO Bus Timing (High-Speed Mode)	163
Figure 44: gSPI Timing	164
Figure 45: WLAN = ON, Bluetooth = ON	168
Figure 46: WLAN = OFF, Bluetooth = OFF	169
Figure 47: WLAN = ON, Bluetooth = OFF	169
Figure 48: WLAN = OFF, Bluetooth = ON	170
Figure 49: 109-Ball WLBGA Package Mechanical Information	172
Figure 50: WLBGA Keep-Out Areas for PCB Layout — Bottom View	173
Figure 51: 208-Bump WLCSP Package Mechanical Information	174
Figure 52: WLCSP Keep-Out Areas for PCB Layout — Bottom View with Bumps Facing Up	175

List of Tables

Table 1: Power-Up/Power-Down/Reset Control Signals	30
Table 2: Crystal Oscillator and External Clock – Requirements and Performance	33
Table 3: External 32.768 kHz Sleep Clock Specifications	35
Table 4: Power Control Pin Description	42
Table 5: SPI and UART Signal Multiplexing	50
Table 6: PCM Interface Timing Specifications (Short Frame Sync, Master Mode)	53
Table 7: PCM Interface Timing Specifications (Short Frame Sync, Slave Mode)	54
Table 8: PCM Interface Timing Specifications (Long Frame Sync, Master Mode)	55
Table 9: PCM Interface Timing Specifications (Long Frame Sync, Slave Mode)	56
Table 10: PCM Burst Mode (Receive Only, Short Frame Sync)	57
Table 11: PCM Burst Mode (Receive Only, Long Frame Sync)	58
Table 12: Example of Common Baud Rates	59
Table 13: UART Timing Specifications	60
Table 14: Timing for I ² S Transmitters and Receivers	62
Table 15: External Coexistence Interface	71
Table 16: SDIO Pin Description	72
Table 17: gSPI Status Field Details	79
Table 18: gSPI Registers	80
Table 19: WLCSP 208–Bump Coordinates	95
Table 20: WLBGA and WLCSP Signal Descriptions	102
Table 21: WLAN GPIO Functions and Strapping Options (Advance Information)	112
Table 22: OTP Select	115
Table 23: GPIO Multiplexing Matrix	116
Table 24: Multiplexed GPIO Signals	117
Table 25: I/O States	118
Table 26: Absolute Maximum Ratings	122
Table 27: Environmental Ratings	123
Table 28: ESD Specifications	123
Table 29: Recommended Operating Conditions and DC Characteristics	124
Table 30: Bluetooth Receiver RF Specifications	128
Table 31: Bluetooth Transmitter RF Specifications	132

Table 32: Local Oscillator Performance.....	133
Table 33: BLE RF Specifications	133
Table 34: FM Receiver Specifications	134
Table 35: 2.4 GHz Band General RF Specifications.....	140
Table 36: WLAN 2.4 GHz Receiver Performance Specifications	141
Table 37: WLAN 2.4 GHz Transmitter Performance Specifications.....	144
Table 38: WLAN 5 GHz Receiver Performance Specifications	145
Table 39: WLAN 5 GHz Transmitter Performance Specifications.....	148
Table 40: General Spurious Emissions Specifications.....	149
Table 41: General Spurious Emissions Specifications.....	150
Table 42: Core Buck Switching Regulator (CBUCK) Specifications	151
Table 43: LDO3P3 Specifications	153
Table 44: LDO2P5 Specifications	154
Table 45: HISCDVDD LDO Specifications	155
Table 46: CLDO Specifications	156
Table 47: LNLDO Specifications	157
Table 48: Typical WLAN Power Consumption	158
Table 49: Bluetooth and FM Current Consumption	160
Table 50: SDIO Bus Timing Parameters (Default Mode).....	161
Table 51: SDIO Bus Timing Parameters (High-Speed Mode).....	163
Table 52: gSPI Timing Parameters.....	164
Table 53: HSIC Timing Parameters	165
Table 54: JTAG Timing Characteristics.....	166
Table 55: Bluetooth Random Bit Generator Start-Up Time	167
Table 56: Package Thermal Characteristics	171

Not Recommended for New Designs

About This Document

Purpose and Audience

This document provides details of the functional, operational, and electrical characteristics of the Broadcom® BCM4334X. It is intended for hardware design, application, and OEM engineers.

Acronyms and Abbreviations

In most cases, acronyms and abbreviations are defined on first use.

For a comprehensive list of acronyms and other terms used in Broadcom documents, go to:
<http://www.broadcom.com/press/glossary.php>.

Document Conventions

The following conventions may be used in this document:

<i>Convention</i>	<i>Description</i>
Bold	User input and actions: for example, type exit , click OK , press ALT+C
Monospace	Code: #include <iostream> HTML: <td rowspan = 3> Command line commands and parameters: w1 [-1] <command>
< >	Placeholders for <i>required</i> elements: enter your <username> or w1 <command>
[]	Indicates <i>optional</i> command-line parameters: w1 [-1] Indicates bit and byte ranges (inclusive): [0:3] or [7:0]

References

The references in this section may be used in conjunction with this document.



Note: Broadcom provides customer access to technical documentation and software through its Customer Support Portal (CSP) and Downloads & Support site (see [Technical Support](#)).

For Broadcom documents, replace the “x” in the document number with the largest number available in the repository to ensure that you have the most current version of the document.

<i>Document (or Item) Name</i>	<i>Number</i>	<i>Source</i>
[1] PCB Layout Guidelines and Component Selection for Optimized PMU Performance	4334-AN20x-R	Broadcom CSP

Technical Support

Broadcom provides customer access to a wide range of information, including technical documentation, schematic diagrams, product bill of materials, PCB layout information, and software updates through its customer support portal (<https://support.broadcom.com>). For a CSP account, contact your Sales or Engineering support representative.

In addition, Broadcom provides other product support through its Downloads & Support site (<http://www.broadcom.com/support/>).

Not Recommended for New Designs

Section 1: BCM4334 Overview

Overview

The Broadcom® BCM4334 single-chip device provides the highest level of integration for a mobile or handheld wireless system, with integrated IEEE 802.1 a/b/g/n MAC/baseband/radio, Bluetooth 4.0 + EDR (enhanced data rate), and FM receiver. It provides a small form-factor solution with minimal external components to drive down cost for mass volumes and allows for handheld device flexibility in size, form, and function. Comprehensive power management circuitry and software ensure the system can meet the needs of highly mobile devices that require minimal power consumption and reliable operation.

Figure 2 shows the interconnect of all the major physical blocks in the BCM4334 and their associated external interfaces, which are described in greater detail in the following sections.

Figure 2: BCM4334 Block Diagram

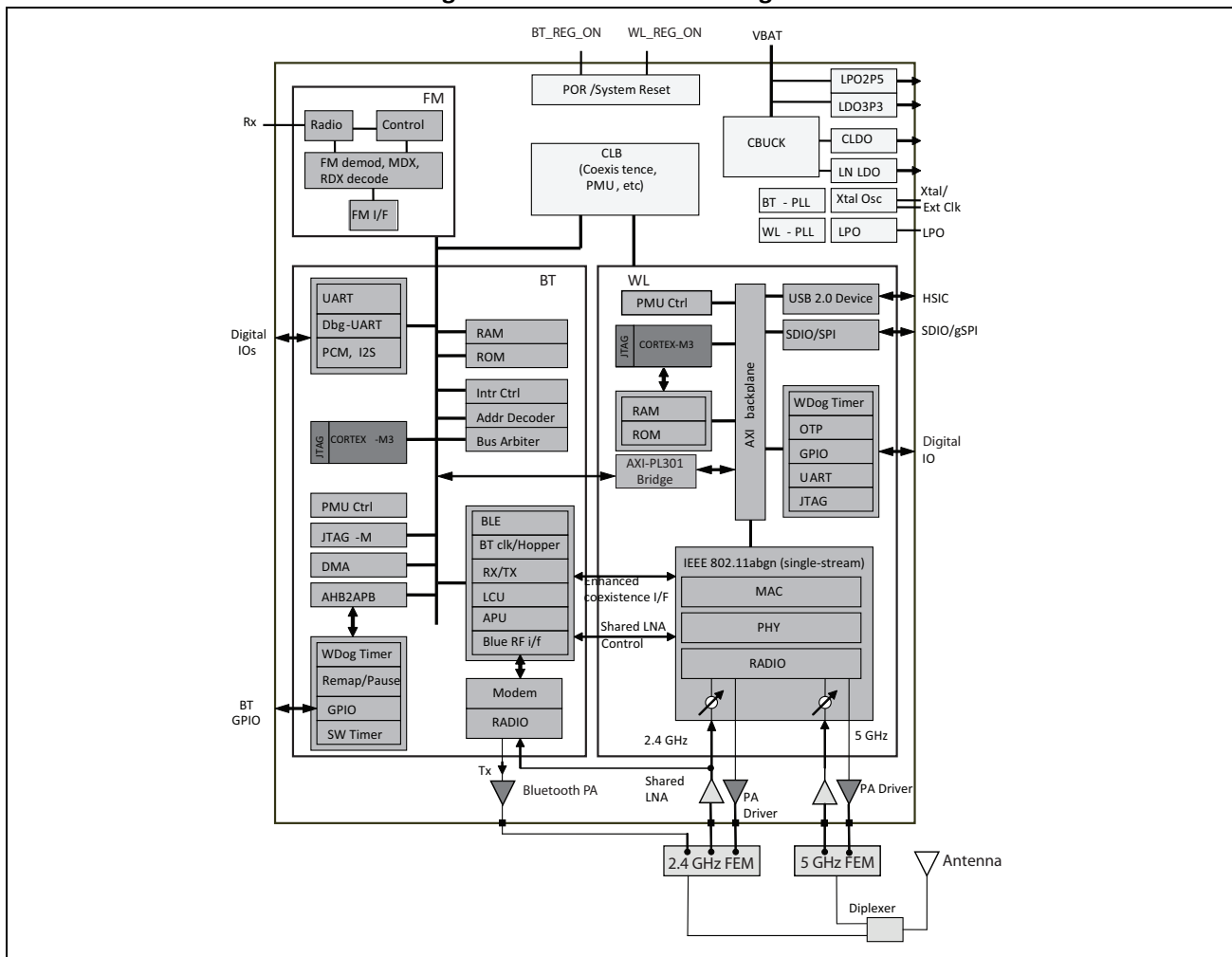

Not Recommended for New Designs

Features

The BCM4334 supports the following features:

- IEEE 802.11a/b/g/n dual-band radio— non-simultaneous dual-band operation
- Bluetooth v4.0 + EDR with integrated Class 1 PA
- Concurrent Bluetooth, FM (RX) RDS/RBDS, and WLAN operation
- On-chip WLAN driver execution capable of supporting IEEE 802.11 functionality
- Single- and dual-antenna support
 - Single antenna with shared LNA
 - Simultaneous BT/WLAN receive with single antenna
- WLAN host interface options:
 - SDIO v2.0
 - gSPI— up to 48 MHz clock rate
 - HSIC (USB device interface for short distance on-board applications)
- BT host digital interface (can be used concurrently with above interfaces):
 - UART (up to 4 Mbps)
- ECI— enhanced coexistence support, ability to coordinate BT SCO transmissions around WLAN receives
- I²S/PCM for FM/BT audio, HCI for FM block control
- HCI high-speed UART (H4, H4+, H5) transport support
- Wideband speech support (16 bits linear data, MSB first, left justified at 4K samples/s for transparent air coding, both through I²S and PCM interface)
- Bluetooth SmartAudio® technology improves voice and music quality to headsets
- Bluetooth low power inquiry and page scan
- Bluetooth Low Energy (BLE) support
- Bluetooth Packet Loss Concealment (PLC)
- Bluetooth Wide Band Speech (WBS)
- FM advanced internal antenna support
- FM auto search/tuning functions
- FM multiple audio routing options: I²S, PCM, eSCO, A2DP
- FM mono-stereo blend and switch, and soft mute support
- FM audio pause detect support
- Audio rate-matching algorithms
- Multiple simultaneous A2DP audio stream
- FM over Bluetooth operation and on-chip stereo headset emulation (SBC, MP3, and AAC)
- MP3, AAC on-chip decoder for low power music playback

Not Recommended for New Designs

Standards Compliance

The BCM4334 supports the following standards:

- Bluetooth 2.1 + EDR
- Bluetooth 3.0 + HS
- Bluetooth 4.0 (Bluetooth Low Energy)
- 65 MHz to 108 MHz FM bands (US, Europe, and Japan)
- IEEE 802.11n — Handheld Device Class (Section 11)
- IEEE 802.11a
- IEEE 802.11b
- IEEE 802.11g
- IEEE 802.11d
- IEEE 802.11h
- IEEE 802.11i

The BCM4334 will support the following future drafts/standards:

- IEEE 802.11r — Fast Roaming (between APs)
- IEEE 802.11k — Resource Management
- IEEE 802.11w — Secure Management Frames
- IEEE 802.11 Extensions:
 - IEEE 802.11e QoS Enhancements (as per the WMM® specification is already supported)
 - IEEE 802.11h 5 GHz Extensions
 - IEEE 802.11i MAC Enhancements
 - IEEE 802.11r Fast Roaming Support
 - IEEE 802.11k Radio Resource Measurement

The BCM4334 supports the following security features and proprietary protocols:

- Security:
 - WEP
 - WPA™ Personal
 - WPA2™ Personal
 - WMM
 - WMM-PS (U-APSD)
 - WMM-SA
 - WAPI
 - AES (Hardware Accelerator)
 - TKIP (HW Accelerator)
 - CKIP (SW Support)

Not Recommended for New Designs

- Proprietary Protocols:
 - CCXv2
 - CCXv3
 - CCXv4
 - CCXv5
 - WFAEC
- IEEE 802.15.2 Coexistence Compliance — on silicon solution compliant with IEEE 3 wire requirements

Mobile Phone Usage Model

The BCM4334 incorporates a number of unique features to simplify integration into mobile phone platforms. Its flexible PCM and UART interfaces enable it to transparently connect with the existing circuits. In addition, the TCXO and LPO inputs allow the use of existing handset features to further minimize the size, power, and cost of the complete system.

- The PCM interface provides multiple modes of operation to support both master and slave as well as hybrid interfacing to single or multiple external codec devices.
- The UART interface supports hardware flow control with tight integration to power control sideband signaling to support the lowest power operation.
- The TCXO interface accommodates any of the typical reference frequencies used by cell phones.
- FM digital interfaces can use either I²S or PCM.
- The highly linear design of the radio transceiver ensures that the device has the lowest spurious emissions output regardless of the state of operation. It has been fully characterized in the global cellular bands.
- The transceiver design has excellent blocking (eliminating desensitization of the Bluetooth receiver) and intermodulation performance (distortion of the transmitted signal caused by the mixing of the cellular and Bluetooth transmissions) in the presence of any cellular transmission (GSM®, GPRS, CDMA, WCDMA, or iDEN). Minimal external filtering is required for integration inside the handset.

Not Recommended for New Designs

The BCM4334 is designed to provide direct interface with new and existing handset designs as shown in Figure 3.

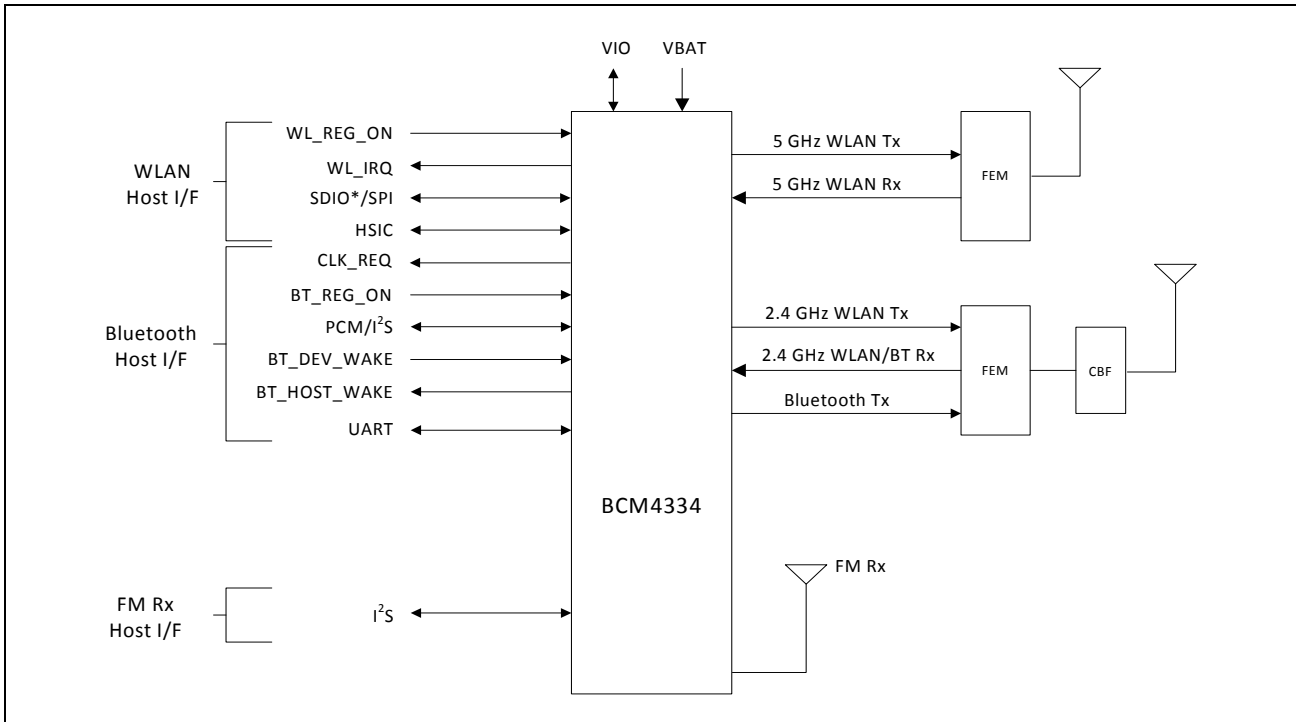

Figure 3: Mobile Phone System Block Diagram

Not Recommended for New Designs

Section 2: Power Supplies and Power Management

Power Supply Topology

One Buck regulator, multiple LDO regulators, and a Power Management Unit (PMU) are integrated into the BCM4334. All regulators are programmable via the PMU. These blocks simplify power supply design for Bluetooth, WLAN, and FM functions in embedded designs.

A single VBAT (2.3V to 4.8V) and VIO supply (1.8V to 3.3V) can be used, with all additional voltages being provided by the regulators in the BCM4334.

Two control signals, BT_REG_ON and WL_REG_ON, are used to power-up the regulators and take the respective section out of reset. The CBUCK CLDO and LNLDO power up when any of the reset signals are deasserted. All regulators are powered down only when both BT_REG_ON and WL_REG_ON are deasserted. The CLDO and LNLDO may be turned off/on based on the dynamic demands of the digital baseband.

The BCM4334 allows for an extremely low power-consumption mode by completely shutting down the CBUCK, CLDO, and LNDLO regulators. When in this state, LPLDO1 and LPLDO2 (which are low-power linear regulators that are supplied by the system VIO supply) provide the BCM4334 with all the voltages it requires, further reducing leakage currents.

BCM4334 PMU Features

- VBAT to 1.35Vout (372 mA maximum) Core-Buck (CBUCK) switching regulator
- VBAT to 3.3Vout (50 mA maximum) LDO3P3 (external-capacitor)
- VBAT to 2.5Vout (70 mA maximum) LDO2P5 (external-capacitor)
- 1.35V to 1.2Vout (100 mA maximum) LNLDO (external-capacitor)
- 1.35V to 1.2Vout (150 mA maximum) CLDO (external-capacitor)
- 1.35V to 1.2Vout (80 mA maximum) HSICDVDD LDO (external-capacitor)
- Additional internal LDOs (not externally accessible)

Figure 4 on page 26 shows the regulators and a typical power topology.

Not Recommended for New Designs

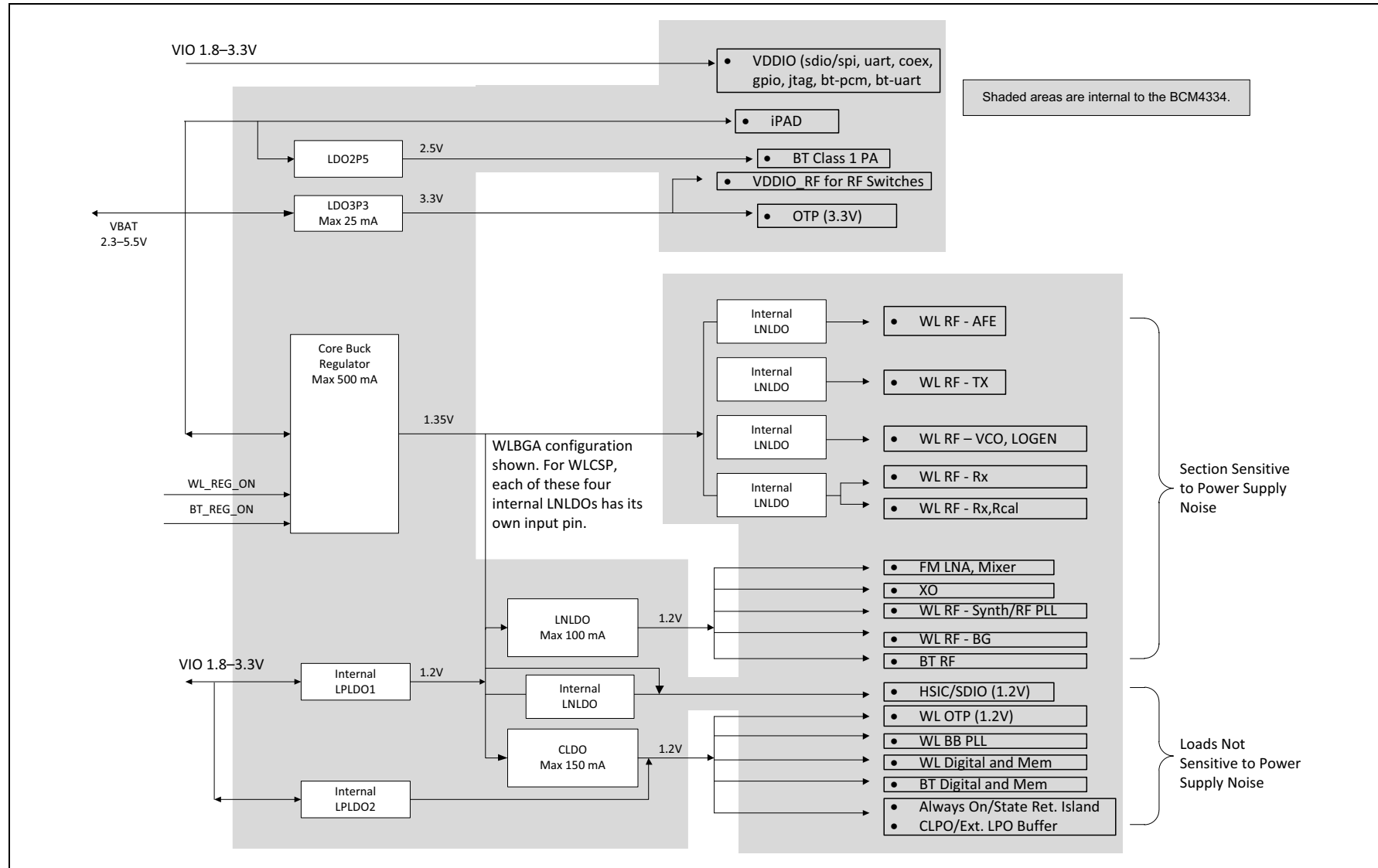

Figure 4: Typical Power Topology

Not Recommended for New Designs

WLAN Power Management

The BCM4334 has been designed with the stringent power consumption requirements of mobile devices in mind. All areas of the chip design are optimized to minimize power consumption. Silicon processes and cell libraries were chosen to reduce leakage current and supply voltages. Additionally, the BCM4334 integrated RAM is a high V_t memory with dynamic clock control. The dominant supply current consumed by the RAM is leakage current only. Additionally, the BCM4334 includes an advanced WLAN power management unit (PMU) sequencer. The PMU sequencer provides significant power savings by putting the BCM4334 into various power management states appropriate to the current environment and activities that are being performed. The power management unit enables and disables internal regulators, switches, and other blocks based on a computation of the required resources and a table that describes the relationship between resources and the time needed to enable and disable them. Power up sequences are fully programmable. Configurable, free-running counters (running at 32.768 kHz LPO clock) in the PMU sequencer are used to turn on/turn off individual regulators and power switches. Clock speeds are dynamically changed (or gated altogether) for the current mode. Slower clock speeds are used wherever possible.

The BCM4334 WLAN power states are described as follows:

- Active mode — All WLAN blocks in the BCM4334 are powered up and fully functional with active carrier sensing and frame transmission and receiving. All required regulators are enabled and put in the most efficient mode based on the load current. Clock speeds are dynamically adjusted by the PMU sequencer.
- Doze mode — The radio, analog domains, and most of the linear regulators are powered down. The rest of the BCM4334 remains powered up in an IDLE state. All main clocks (PLL, crystal oscillator or TCXO) are shut down to reduce active power to the minimum. The 32.768 kHz LPO clock is available only for the PMU sequencer. This condition is necessary to allow the PMU sequencer to wake up the chip and transition to Active mode. In Doze mode, the primary power consumed is due to leakage current.
- Deep-sleep mode — Most of the chip including both analog and digital domains and most of the regulators are powered off. Logic states in the digital core are saved and preserved into a retention memory in the always-ON domain before the digital core is powered off. Upon a wake-up event triggered by the PMU timers, an external interrupt or a host resume through the HSIC or SDIO bus, logic states in the digital core are restored to their pre-deep-sleep settings to avoid lengthy HW reinitialization.
- Power-down mode — The BCM4334 is effectively powered off by shutting down all internal regulators. The chip is brought out of this mode by external logic re-enabling the internal regulators.

PMU Sequencing

The PMU sequencer is responsible for minimizing system power consumption. It enables and disables various system resources based on a computation of the required resources and a table that describes the relationship between resources and the time needed to enable and disable them.

Resource requests may come from several sources: clock requests from cores, the minimum resources defined in the ResourceMin register, and the resources requested by any active resource request timers. The PMU sequencer maps clock requests into a set of resources required to produce the requested clocks.

Each resource is in one of four states: enabled, disabled, transition_on, and transition_off and has a timer that contains 0 when the resource is enabled or disabled and a non-zero value in the transition states. The timer is loaded with the time_on or time_off value of the resource when the PMU determines that the resource must be enabled or disabled. That timer decrements on each 32.768 kHz PMU clock. When it reaches 0, the state changes from transition_off to disabled or transition_on to enabled. If the time_on value is 0, the resource can go immediately from disabled to enabled. Similarly, a time_off value of 0 indicates that the resource can go immediately from enabled to disabled. The terms enable sequence and disable sequence refer to either the immediate transition or the timer load-decrement sequence.

During each clock cycle, the PMU sequencer performs the following actions:

1. Computes the required resource set based on requests and the resource dependency table.
2. Decrements all timers whose values are non zero. If a timer reaches 0, the PMU clears the ResourcePending bit for the resource and inverts the ResourceState bit.
3. Compares the request with the current resource status and determines which resources must be enabled or disabled.
4. Initiates a disable sequence for each resource that is enabled, no longer being requested, and has no powered up dependents.
5. Initiates an enable sequence for each resource that is disabled, is being requested, and has all of its dependencies enabled.

Power-off Shutdown

The BCM4334 provides a low-power shutdown feature that allows the device to be turned off while the host, and any other devices in the system, remain operational. When the BCM4334 is not needed in the system, VDDIO_RF and VDDC are shut down while VDDIO remains powered. This allows the BCM4334 to be effectively off while keeping the I/O pins powered so that they do not draw extra current from any other devices connected to the I/O.

During a low-power shut-down state, provided VDDIO remains applied to the BCM4334, all outputs are tristated, and most inputs signals are disabled. Input voltages must remain within the limits defined for normal operation. This is done to prevent current paths or create loading on any digital signals in the system, and enables the BCM4334 to be fully integrated in an embedded device and take full advantage of the lowest power-savings modes.

Two signals on the BCM4334, the frequency reference input (WRF_XTAL_CAB_OP) and the LPO_IN input, are designed to be high-impedance inputs that do not load down the driving signal even if the chip does not have VDDIO power applied to it.

When the BCM4334 is powered on from this state, it is the same as a normal power-up and the device does not retain any information about its state from before it was powered down.

Power-Up/Power-Down/Reset Circuits

The BCM4334 has two signals (see [Table 1](#)) that enable or disable the Bluetooth and WLAN circuits and the internal regulator blocks, allowing the host to control power consumption. For timing diagrams of these signals and the required power-up sequences, see [Section 22: “Power-Up Sequence and Timing,”](#) on page 159.

Table 1: Power-Up/Power-Down/Reset Control Signals

Signal	Description
WL_REG_ON	This signal is used by the PMU (with BT_REG_ON) to power up the WLAN section. It is also OR-gated with the BT_REG_ON input to control the internal BCM4334 regulators. When this pin is high, the regulators are enabled and the WLAN section is out of reset. When this pin is low, the WLAN section is in reset. If BT_REG_ON and WL_REG_ON are both low, the regulators are disabled. This pin has an internal 200 k Ω pull-down resistor that is enabled by default. It can be disabled through programming.
BT_REG_ON	This signal is used by the PMU (with WL_REG_ON) to decide whether or not to power down the internal BCM4334 regulators. If BT_REG_ON and WL_REG_ON are low, the regulators will be disabled. This pin has an internal 200 k Ω pull-down resistor that is enabled by default. It can be disabled through programming.

Section 3: Frequency References

An external crystal is used for generating all radio frequencies and normal operation clocking. As an alternative, an external frequency reference driven by a temperature-compensated crystal oscillator (TCXO) signal may be used. In addition, a low-power oscillator (LPO) is provided for lower power mode timing.



Note: The crystal and TCXO implementations have different power supplies (WRF_XTAL_VDD1P2 for crystal, WRF_TCXO_VDD for TCXO).

Crystal Interface and Clock Generation

The BCM4334 can use an external crystal to provide a frequency reference. The recommended configuration for the crystal oscillator including all external components is shown in Figure 5. Consult the reference schematics for the latest configuration.

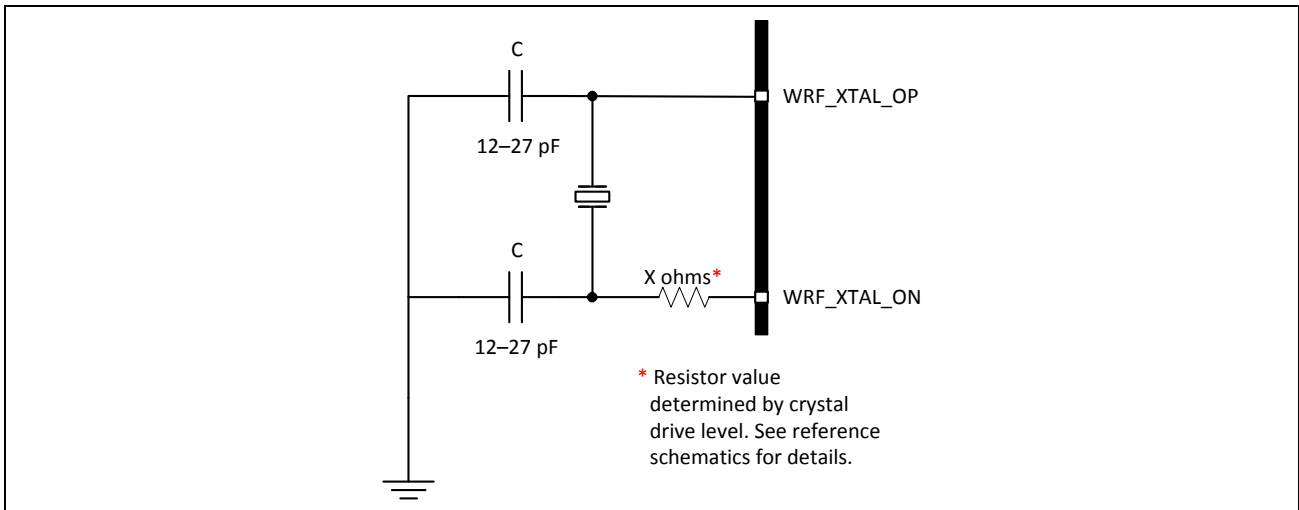

Figure 5: Recommended Oscillator Configuration

A fractional-N synthesizer in the BCM4334 generates the radio frequencies, clocks, and data/packet timing, enabling it to operate using a wide selection of frequency references.

For SDIO and HSIC applications the default frequency reference is a 37.4 MHz crystal or TCXO. The signal characteristics for the crystal interface are listed in Table 2 on page 32.



Note: Although the fractional-N synthesizer can support alternative reference frequencies, frequencies other than the default require support to be added in the driver, plus additional extensive system testing. Contact Broadcom for further details.

Not Recommended for New Designs

TCXO

As an alternative to a crystal, an external precision TCXO can be used as the frequency reference, provided that it meets the Phase Noise requirements listed in [Table 2](#). When the clock is provided by an external TCXO, there are two possible connection methods, as shown in [Figure 6](#) and [Figure 7](#):

1. If the TCXO is dedicated to driving the BCM4334, it should be connected to the WRF_XTAL_OP pin through an external 1000 pF coupling capacitor, as shown in [Figure 6](#). The internal clock buffer connected to this pin will be turned OFF when the BCM4334 goes into sleep mode. When the clock buffer turns ON and OFF there will be a small impedance variation. Power must be supplied to the WRF_XTAL_VDD1P2 pin.
2. For 2.4 GHz operation only, an alternative is to DC-couple the TCXO to the WRF_TCXO_CK pin, as shown in [Figure 7](#). Use this method when the same TCXO is shared with other devices and a change in the input impedance is not acceptable because it may cause a frequency shift that cannot be tolerated by the other device sharing the TCXO. This pin is connected to a clock buffer powered from WRF_TCXO_VDD. If the power supply to this buffer is always on (even in sleep mode), the clock buffer is always on, thereby ensuring a constant input impedance in all states of the device. The maximum current drawn from WRF_TCXO_VDD is approximately 500 μ A.

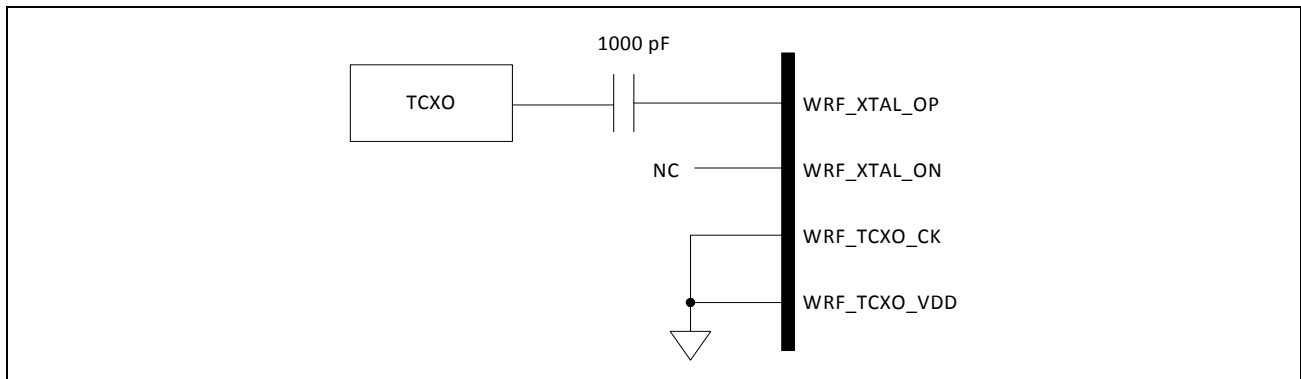

Figure 6: Recommended Circuit to Use with an External Dedicated TCXO

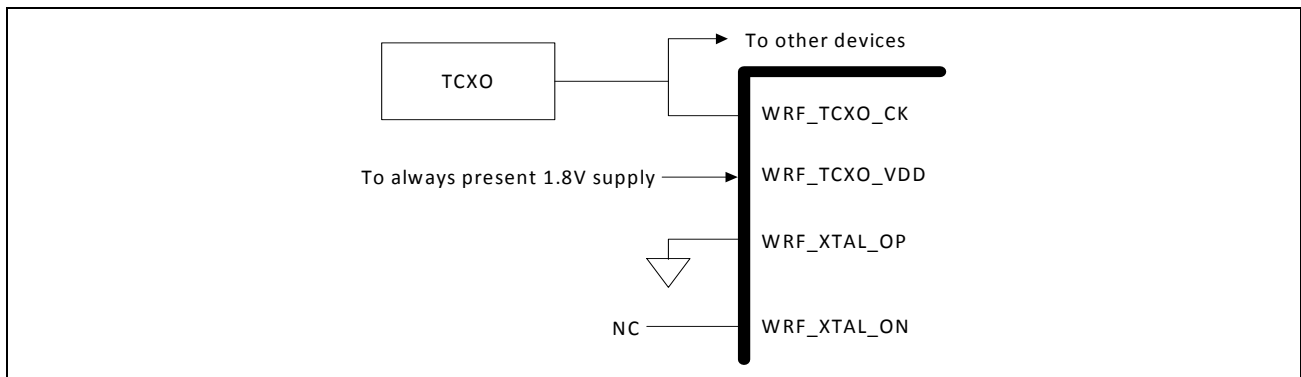

Figure 7: Recommended Circuit to Use with an External Shared TCXO

Not Recommended for New Designs

Table 2: Crystal Oscillator and External Clock – Requirements and Performance

Parameter	Conditions/Notes	Crystal ^a			External Frequency Reference ^{b c}			Units
		Min	Typ	Max	Min	Typ	Max	
Frequency	–	Between 12 MHz and 52 MHz ^{d,e}						
Crystal load capacitance	–	–	12	–	–	–	–	pF
ESR	–	–	–	60	–	–	–	Ω
Drive level	External crystal requirement	200 ^f	–	–	–	–	–	μW
Input impedance (WRF_XTAL_OP)	Resistive	30	100	–	30	100	–	kΩ
	Capacitive	–	–	7.5	–	–	7.5	pF
Input impedance (WRF_TCXO_IN)	Resistive	–	–	–	30k	100	–	Ω
	Capacitive	–	–	–	–	–	4	pF
WRF_XTAL_OP Input low level	DC-coupled digital signal	–	–	–	0	–	0.2	V
WRF_XTAL_OP Input high level	DC-coupled digital signal	–	–	–	1.0	–	1.26	V
WRF_XTAL_OP input voltage	AC-coupled analog signal (see Figure 6)	–	–	–	400	–	1200	mV _{p-p}
WRF_TCXO_IN Input voltage	DC-coupled analog signal (see Figure 7)	–	–	–	400	–	1980	mV _{p-p}
Frequency tolerance over the lifetime of the equipment, including temperature	Without trimming	–20	–	20	–20	–	20	ppm
Duty cycle	37.4 MHz clock	–	–	–	40	50	60	%
Phase Noise (802.11b/g)	37.4 MHz clock at 10 kHz offset	–	–	–	–	–	–131	dBc/Hz
	37.4 MHz clock at 100 kHz or greater offset	–	–	–	–	–	–138	dBc/Hz
Phase Noise (802.11a)	37.4 MHz clock at 10 kHz offset	–	–	–	–	–	–139	dBc/Hz
	37.4 MHz clock at 100 kHz or greater offset	–	–	–	–	–	–146	dBc/Hz
Phase Noise (802.11n, 2.4 GHz)	37.4 MHz clock at 10 kHz offset	–	–	–	–	–	–136	dBc/Hz
	37.4 MHz clock at 100 kHz or greater offset	–	–	–	–	–	–143	dBc/Hz
Phase Noise (802.11n, 5 GHz)	37.4 MHz clock at 10 kHz offset	–	–	–	–	–	–144	dBc/Hz
	37.4 MHz clock at 100 kHz or greater offset	–	–	–	–	–	–151	dBc/Hz

a. (Crystal) Use WRF_XTAL_OP and WRF_XTAL_ON, internal power to pin WRF_XTAL_VDD1P2.

b. (TCXO) See “TCXO” on page 31 for alternative connection methods.

c. For a clock reference other than 37.4 MHz, $20 \times \log_{10}(f/37.4)$ dB should be added to the limits, where f = the reference clock frequency in MHz.

Not Recommended for New Designs

- d. BT_TM6 should be tied low for a 52 MHz clock reference. For other frequencies, BT_TM6 should be tied high. Note that 52 MHz is not an auto-detected frequency using the LPO clock.
- e. The frequency step size is approximately 80 Hz resolution.
- f. The crystal should be capable of handling a 200uW drive level from the BCM4334.

Frequency Selection

Any frequency within the ranges specified for the crystal and TCXO reference may be used. These include not only the standard handset reference frequencies of 12, 13, 14.4, 16.2, 16.8, 19.2, 19.44, 19.68, 19.8, 20, 26, 37.4, and 52 MHz, but also other frequencies in this range, with approximately 80 Hz resolution. The BCM4334 must have the reference frequency set correctly in order for any of the UART or PCM interfaces to function correctly, since all bit timing is derived from the reference frequency.



Note: The fractional-N synthesizer can support many reference frequencies. However, frequencies other than the default require support to be added in the driver plus additional, extensive system testing. Contact Broadcom for further details.

The reference frequency for the BCM4334 may be set in the following ways:

- Set the *xtalfreq=xxxxx* parameter in the *nvrn.txt* file (used to load the driver) to correctly match the crystal frequency.
- Auto-detect any of the standard handset reference frequencies using an external LPO clock.

For applications such as handsets and portable smart communication devices, where the reference frequency is one of the standard frequencies commonly used, the BCM4334 automatically detects the reference frequency and programs itself to the correct reference frequency. In order for auto frequency detection to work correctly, the BCM4334 must have a valid and stable 32.768 kHz LPO clock that meets the requirements listed in [Table 3 on page 34](#) and is present during power-on reset.

External 32.768 kHz Low-Power Oscillator

The BCM4334 uses a secondary low frequency clock for low-power-mode timing. Either the internal low-precision LPO or an external 32.768 kHz precision oscillator is required. The internal LPO frequency range is approximately 33 kHz \pm 30% over process, voltage, and temperature, which is adequate for some applications. However, a trade-off caused by this wide LPO tolerance is a small current consumption increase during WLAN power save mode that is incurred by the need to wake up earlier to avoid missing beacons. Whenever possible, the preferred approach for WLAN is to use a precision external 32.768 kHz clock that meets the requirements listed in [Table 3](#).



Note: BTFM operations require the use of an external LPO that meets the requirements listed in [Table 3](#).

Table 3: External 32.768 kHz Sleep Clock Specifications

Parameter	LPO Clock	Units
Nominal input frequency	32.768	kHz
Frequency accuracy	\pm 200	ppm
Duty cycle	30–70	%
Input signal amplitude	200–1800	mV, p-p
Signal type	Square-wave or sine-wave	–
Input impedance ^a	>100	k Ω
	<5	pF
Clock jitter (during initial start-up)	<10,000	ppm

a. When power is applied or switched off.

Not Recommended for New Designs

Section 4: Bluetooth + FM Subsystem Overview

The Broadcom BCM4334 is a Bluetooth 4.0 + EDR-compliant, baseband processor/2.4 GHz transceiver with an integrated FM/RDS/RBDS receiver. It features the highest level of integration and eliminates all critical external components, thus minimizing the footprint, power consumption, and system cost of a Bluetooth plus FM radio solution.

The BCM4334 is the optimal solution for any Bluetooth voice and/or data application that also requires an FM radio receiver. The Bluetooth subsystem presents a standard Host Controller Interface (HCI) via a high speed UART and PCM for audio. The FM subsystem supports the HCI control interface as well as I²S and PCM interfaces. The BCM4334 incorporates all Bluetooth 4.0 features including Secure Simple Pairing, Sniff Subrating, and Encryption Pause and Resume.

The BCM4334 Bluetooth radio transceiver provides enhanced radio performance to meet the most stringent mobile phone temperature applications and the tightest integration into mobile handsets and portable devices. It is fully compatible with any of the standard TCXO frequencies and provides full radio compatibility to operate simultaneously with GPS, WLAN, and cellular radios.

The Bluetooth transmitter also features a Class 1 power amplifier with Class 2 capability.

Features

Major Bluetooth features of the BCM4334 include:

- Supports key features of upcoming Bluetooth standards
- Fully supports Bluetooth Core Specification version 4.0 + (Enhanced Data Rate) EDR features:
 - Adaptive Frequency Hopping (AFH)
 - Quality of Service (QoS)
 - Extended Synchronous Connections (eSCO) — Voice Connections
 - Fast Connect (interlaced page and inquiry scans)
 - Secure Simple Pairing (SSP)
 - Sniff Subrating (SSR)
 - Encryption Pause Resume (EPR)
 - Extended Inquiry Response (EIR)
 - Link Supervision Timeout (LST)
- UART baud rates up to 4 Mbps
- Supports all Bluetooth 4.0 + HS packet types
- Supports maximum Bluetooth data rates over HCI UART
- Multipoint operation with up to seven active slaves
 - Maximum of seven simultaneous active ACL links
 - Maximum of three simultaneous active SCO and eSCO connections with scatternet support

- Trigger Broadcom fast connect (TBFC)
- Narrowband and wideband packet loss concealment
- Scatternet operation with up to four active piconets with background scan and support for scatter mode
- High-speed HCI UART transport support with low-power out-of-band BT_DEV_WAKE and BT_HOST_WAKE signaling (see “Host Controller Power Management” on page 41)
- Channel quality driven data rate and packet type selection
- Standard Bluetooth test modes
- Extended radio and production test mode features
- Full support for power savings modes
 - Bluetooth clock request
 - Bluetooth standard sniff
 - Deep-sleep modes and software regulator shutdown
- TCXO input and auto-detection of all standard handset clock frequencies. Also supports a low-power crystal, which can be used during power save mode for better timing accuracy.

Major FM Radio features include:

- 65 MHz to 108 MHz FM bands supported (US, Europe, and Japan)
- FM subsystem control using the Bluetooth HCI interface
- FM subsystem operates from reference clock inputs.
- Improved audio interface capabilities with full-featured bidirectional PCM and I²S
- I²S can be master or slave.

FM Receiver-Specific Features Include:

- Excellent FM radio performance with 1 μ V sensitivity for 26 dB (S+N)/N
- Signal-dependent stereo/mono blending
- Signal dependent soft mute
- Auto search and tuning modes
- Audio silence detection
- RSSI, IF frequency, status indicators
- RDS and RBDS demodulator and decoder with filter and buffering functions
- Automatic frequency jump

Bluetooth Radio

The BCM4334 has an integrated radio transceiver that has been optimized for use in 2.4 GHz Bluetooth wireless systems. It has been designed to provide low-power, low-cost, robust communications for applications operating in the globally available 2.4 GHz unlicensed ISM band. It is fully compliant with the Bluetooth Radio Specification and EDR specification and meets or exceeds the requirements to provide the highest communication link quality of service.

Transmit

The BCM4334 features a fully integrated zero-IF transmitter. The baseband transmit data is GFSK-modulated in the modem block and upconverted to the 2.4 GHz ISM band in the transmitter path. The transmitter path consists of signal filtering, I/Q upconversion, output power amplifier, and RF filtering. The transmitter path also incorporates $\pi/4$ -DQPSK for 2 Mbps and 8-DPSK for 3 Mbps to support EDR. The transmitter section is compatible to the Bluetooth Low Energy specification. The transmitter PA bias can also be adjusted to provide Bluetooth class 1 or class 2 operation.

Digital Modulator

The digital modulator performs the data modulation and filtering required for the GFSK, $\pi/4$ -DQPSK, and 8-DPSK signal. The fully digital modulator minimizes any frequency drift or anomalies in the modulation characteristics of the transmitted signal and is much more stable than direct VCO modulation schemes.

Digital Demodulator and Bit Synchronizer

The digital demodulator and bit synchronizer take the low-IF received signal and perform an optimal frequency tracking and bit-synchronization algorithm.

Power Amplifier

The fully integrated PA supports Class 1 or Class 2 output using a highly linearized, temperature-compensated design. This provides greater flexibility in front-end matching and filtering. Due to the linear nature of the PA combined with some integrated filtering, external filtering is required to meet the Bluetooth and regulatory harmonic and spurious requirements. For integrated mobile handset applications in which Bluetooth is integrated next to the cellular radio, external filtering can be applied to achieve near thermal noise levels for spurious and radiated noise emissions. The transmitter features a sophisticated on-chip transmit signal strength indicator (TSSI) block to keep the absolute output power variation within a tight range across process, voltage, and temperature.

Not Recommended for New Designs

Receiver

The receiver path uses a low-IF scheme to downconvert the received signal for demodulation in the digital demodulator and bit synchronizer. The receiver path provides a high degree of linearity, an extended dynamic range, and high-order on-chip channel filtering to ensure reliable operation in the noisy 2.4 GHz ISM band. The front-end topology with built-in out-of-band attenuation enables the BCM4334 to be used in most applications with minimal off-chip filtering. For integrated handset operation, in which the Bluetooth function is integrated close to the cellular transmitter, external filtering is required to eliminate the desensitization of the receiver by the cellular transmit signal.

Digital Demodulator and Bit Synchronizer

The digital demodulator and bit synchronizer take the low-IF received signal and perform an optimal frequency tracking and bit synchronization algorithm.

Receiver Signal Strength Indicator

The radio portion of the BCM4334 provides a Receiver Signal Strength Indicator (RSSI) signal to the baseband, so that the controller can take part in a Bluetooth power-controlled link by providing a metric of its own receiver signal strength to determine whether the transmitter should increase or decrease its output power.

Local Oscillator Generation

Local Oscillator (LO) generation provides fast frequency hopping (1600 hops/second) across the 79 maximum available channels. The LO generation subblock employs an architecture for high immunity to LO pulling during PA operation. The BCM4334 uses an internal RF and IF loop filter.

Calibration

The BCM4334 radio transceiver features an automated calibration scheme that is fully self contained in the radio. No user interaction is required during normal operation or during manufacturing to provide the optimal performance. Calibration optimizes the performance of all the major blocks within the radio to within 2% of optimal conditions, including gain and phase characteristics of filters, matching between key components, and key gain blocks. This takes into account process variation and temperature variation. Calibration occurs transparently during normal operation during the settling time of the hops and calibrates for temperature variations as the device cools and heats during normal operation in its environment.

Section 5: Bluetooth Baseband Core

The Bluetooth Baseband Core (BBC) implements all of the time critical functions required for high-performance Bluetooth operation. The BBC manages the buffering, segmentation, and routing of data for all connections. It also buffers data that passes through it, handles data flow control, schedules SCO/ACL TX/RX transactions, monitors Bluetooth slot usage, optimally segments and packages data into baseband packets, manages connection status indicators, and composes and decodes HCI packets. In addition to these functions, it independently handles HCI event types, and HCI command types.

The following transmit and receive functions are also implemented in the BBC hardware to increase reliability and security of the TX/RX data before sending over the air:

- Symbol timing recovery, data deframing, forward error correction (FEC), header error control (HEC), cyclic redundancy check (CRC), data decryption, and data dewatering in the receiver.
- Data framing, FEC generation, HEC generation, CRC generation, key generation, data encryption, and data whitening in the transmitter.

Bluetooth 4.0 Features

The BBC supports all Bluetooth 4.0 features, with the following benefits:

- Dual-mode bluetooth Low Energy (BT and BLE operation)
- Extended Inquiry Response (EIR): Shortens the time to retrieve the device name, specific profile, and operating mode.
- Encryption Pause Resume (EPR): Enables the use of Bluetooth technology in a much more secure environment.
- Sniff Subrating (SSR): Optimizes power consumption for low duty cycle asymmetric data flow, which subsequently extends battery life.
- Secure Simple Pairing (SSP): Reduces the number of steps for connecting two devices, with minimal or no user interaction required.
- Link Supervision Time Out (LSTO): Additional commands added to HCI and Link Management Protocol (LMP) for improved link time-out supervision.
- QoS enhancements: Changes to data traffic control, which results in better link performance. Audio, human interface device (HID), bulk traffic, SCO, and enhanced SCO (eSCO) are improved with the erroneous data (ED) and packet boundary flag (PBF) enhancements.

Bluetooth Low Energy

The BCM4334 is forward compatible with the impending Bluetooth Low Energy operating mode, which provides a dramatic reduction in the power consumption of the Bluetooth radio and baseband. The primary application for this mode is to provide support for low data rate devices, such as sensors and remote controls.

Link Control Layer

The link control layer is part of the Bluetooth link control functions that are implemented in dedicated logic in the link control unit (LCU). This layer consists of the command controller that takes commands from the software, and other controllers that are activated or configured by the command controller, to perform the link control tasks. Each task performs a different state in the Bluetooth Link Controller.

- Major states:
 - Standby
 - Connection
- Substates:
 - Page
 - Page Scan
 - Inquiry
 - Inquiry Scan
 - Sniff

Test Mode Support

The BCM4334 fully supports Bluetooth Test mode as described in Part I:1 of the *Specification of the Bluetooth System Version 3.0*. This includes the transmitter tests, normal and delayed loopback tests, and reduced hopping sequence.

In addition to the standard Bluetooth Test Mode, the BCM4334 also supports enhanced testing features to simplify RF debugging and qualification and type-approval testing. These features include:

- Fixed frequency carrier wave (unmodulated) transmission
 - Simplifies some type-approval measurements (Japan)
 - Aids in transmitter performance analysis
- Fixed frequency constant receiver mode
 - Receiver output directed to I/O pin
 - Allows for direct BER measurements using standard RF test equipment
 - Facilitates spurious emissions testing for receive mode
- Fixed frequency constant transmission
 - Eight-bit fixed pattern or PRBS-9
 - Enables modulated signal measurements with standard RF test equipment

Not Recommended for New Designs

Bluetooth Power Management Unit

The Bluetooth Power Management Unit (PMU) provides power management features that can be invoked by either software through power management registers or packet handling in the baseband core. The power management functions provided by the BCM4334 are:

- [RF Power Management](#)
- [Host Controller Power Management](#)
- [BBC Power Management](#)
- [FM Power Management](#)

RF Power Management

The BBC generates power-down control signals for the transmit path, receive path, PLL, and power amplifier to the 2.4 GHz transceiver. The transceiver then processes the power-down functions accordingly.

Host Controller Power Management

When running in UART mode, the BCM4334 may be configured so that dedicated signals are used for power management hand-shaking between the BCM4334 and the host. The basic power saving functions supported by those hand-shaking signals include the standard Bluetooth defined power savings modes and standby modes of operation.

[Table 4](#) describes the power-control hand-shake signals used with the UART interface.

Table 4: Power Control Pin Description

Signal	Mapped to Pin	Type	Description
BT_DEV_WAKE	BT_GPIO_0	I	<p>Bluetooth device wake-up: Signal from the host to the BCM4334 indicating that the host requires attention.</p> <ul style="list-style-type: none"> • Asserted: The Bluetooth device must wake-up or remain awake. • Deasserted: The Bluetooth device may sleep when sleep criteria are met. <p>The polarity of this signal is software configurable and can be asserted high or low.</p>
BT_HOST_WAKE	BT_GPIO_1	O	<p>Host wake up. Signal from the BCM4334 to the host indicating that the BCM4334 requires attention.</p> <ul style="list-style-type: none"> • Asserted: host device must wake-up or remain awake. • Deasserted: host device may sleep when sleep criteria are met. <p>The polarity of this signal is software configurable and can be asserted high or low.</p>

Table 4: Power Control Pin Description (Cont.)

Signal	Mapped to Pin	Type	Description
CLK_REQ	BT_CLK_REQ_OUT WL_CLK_REQ_OUT	0	The BCM4334 asserts CLK_REQ when Bluetooth or WLAN wants the host to turn on the reference clock. The CLK_REQ polarity is active-high. Add an external 100 kΩ pull-down resistor to ensure the signal is deasserted when the BCM4334 powers up or resets when VDDIO is present.

Note: Pad function Control Register is set to 0 for these pins. See “Multiplexed Bluetooth GPIO Signals” on page 110 for more details.

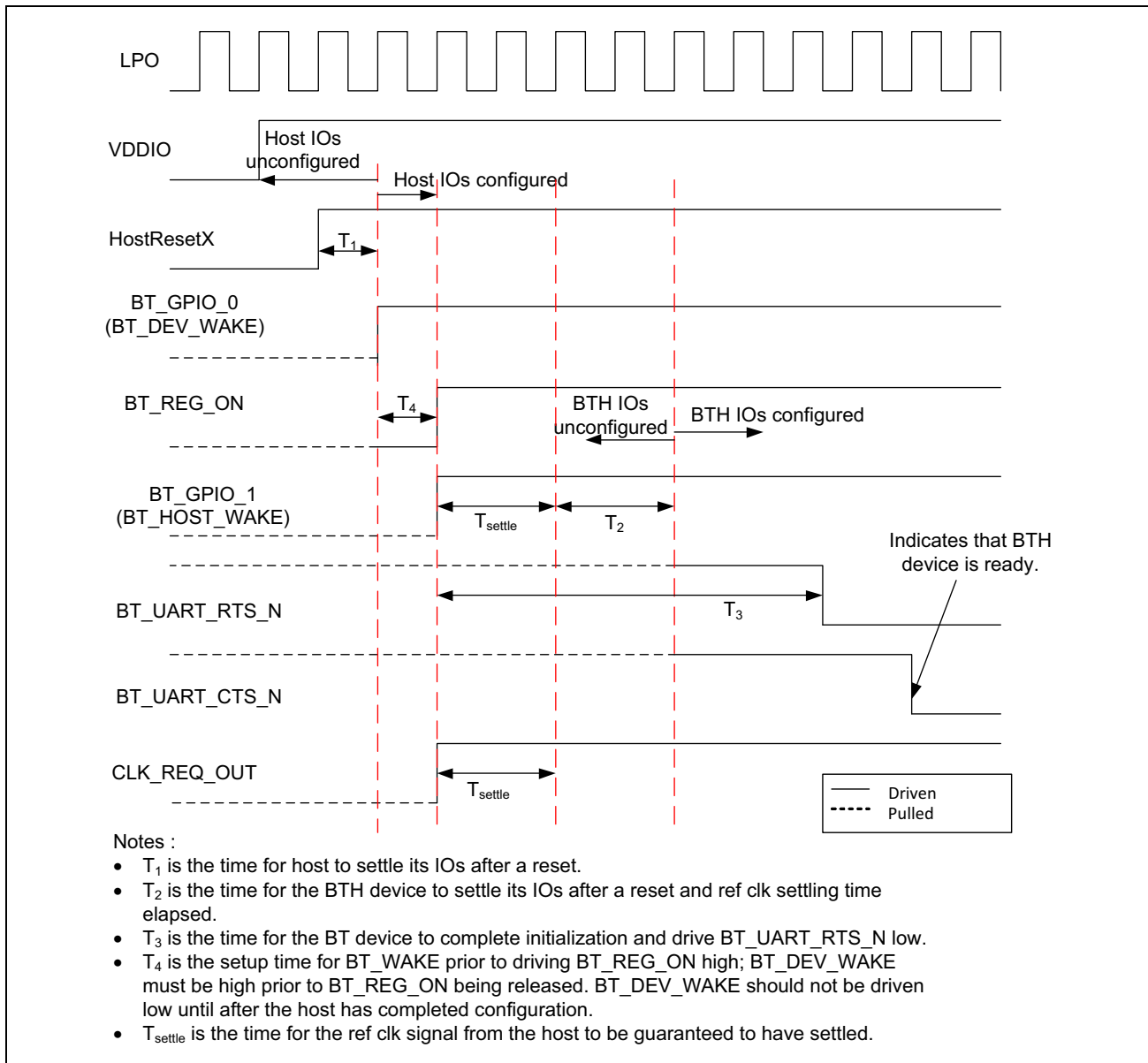

Figure 8: Startup Signaling Sequence

Not Recommended for New Designs

BBC Power Management

The following are low-power operations for the BBC:

- Physical layer packet-handling turns the RF on and off dynamically within transmit/receive packets.
- Bluetooth-specified low-power connection modes: sniff, hold, and park. While in these modes, the BCM4334 runs on the low-power oscillator and wakes up after a predefined time period.
- A low-power shutdown feature allows the device to be turned off while the host and any other devices in the system remain operational. When the BCM4334 is not needed in the system, the RF and core supplies are shut down while the I/O remains powered. This allows the BCM4334 to effectively be off while keeping the I/O pins powered so they do not draw extra current from any other devices connected to the I/O.

During the low-power shut-down state, provided VDDIO remains applied to the BCM4334, all outputs are tri-stated, and most input signals are disabled. Input voltages must remain within the limits defined for normal operation. This is done to prevent current paths or create loading on any digital signals in the system and enables the BCM4334 to be fully integrated in an embedded device to take full advantage of the lowest power-saving modes.

Two BCM4334 input signals are designed to be high-impedance inputs that do not load the driving signal even if the chip does not have VDDIO power supplied to it: the frequency reference input (WRF_TCXO_IN) and the 32.768 kHz input (LPO). When the BCM4334 is powered on from this state, it is the same as a normal power-up, and the device does not contain any information about its state from the time before it was powered down.

FM Power Management

The BCM4334 FM subsystem can operate independently of, or in tandem with, the Bluetooth RF and BBC subsystems. The FM subsystem power management scheme operates in conjunction with the Bluetooth RF and BBC subsystems. The FM block does not have a low power state, it is either on or off.

Wideband Speech

The BCM4334 provides support for wideband speech (WBS) using on-chip Smart Audio technology. The BCM4334 can perform subband-codec (SBC), as well as mSBC, encoding and decoding of linear 16 bits at 16 kHz (256 Kbps rate) transferred over the PCM bus.

Packet Loss Concealment

Packet Loss Concealment (PLC) improves apparent audio quality for systems with marginal link performance. Bluetooth messages are sent in packets. When a packet is lost, it creates a gap in the received audio bit-stream. Packet loss can be mitigated in several ways:

- Fill in zeros.
- Ramp down the output audio signal toward zero (this is the method used in current Bluetooth headsets).
- Repeat the last frame (or packet) of the received bit-stream and decode it as usual (frame repeat).

These techniques cause distortion and popping in the audio stream. The BCM4334 uses a proprietary waveform extension algorithm to provide dramatic improvement in the audio quality. [Figure 9](#) and [Figure 10](#) show audio waveforms with and without Packet Loss Concealment. Broadcom PLC/BEC algorithms also support wide band speech.

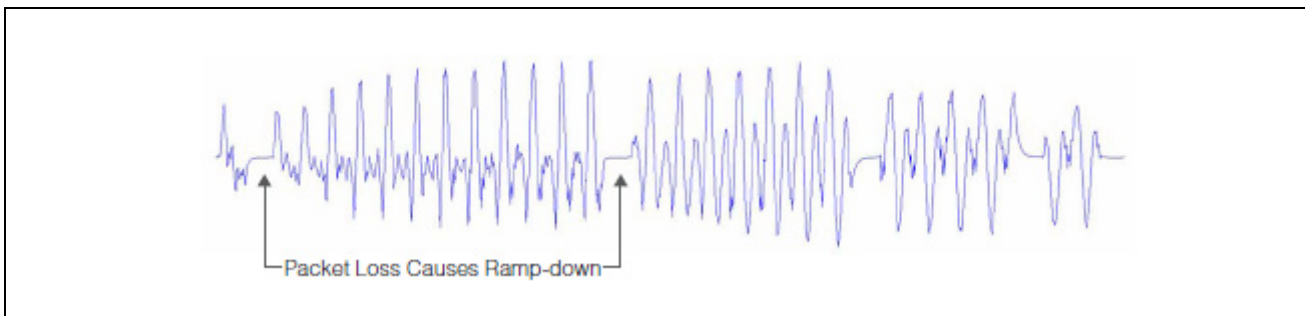

Figure 9: CVSD Decoder Output Waveform Without PLC

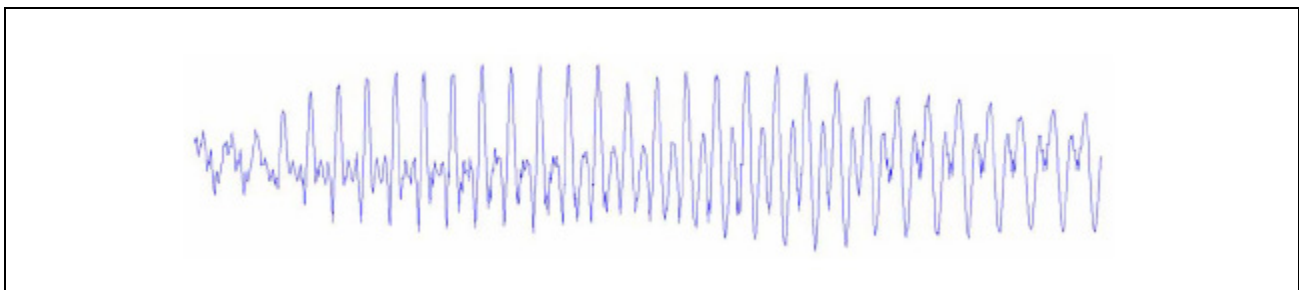

Figure 10: CVSD Decoder Output Waveform After Applying PLC

Audio Rate-Matching Algorithms

The BCM4334 has an enhanced rate-matching algorithm that uses interpolation algorithms to reduce audio stream jitter that may be present when the rate of audio data coming from the host is not the same as the Bluetooth or FM audio data rates.

Codec Encoding

The BCM4334 can support SBC and mSBC encoding and decoding for wideband speech.

Multiple Simultaneous A2DP Audio Stream

The BCM4334 has the ability to take a single audio stream and output it to multiple Bluetooth devices simultaneously. This allows a user to share his or her music (or any audio stream) with a friend.

FM Over Bluetooth

FM Over Bluetooth enables the BCM4334 to stream data from FM over Bluetooth without requiring the host to be awake. This can significantly extend battery life for usage cases where someone is listening to FM radio on a Bluetooth headset.

Burst Buffer Operation

The BCM4334 has a data buffer that can buffer data being sent over the HCI and audio transports, then send the data at an increased rate. This mode of operation allows the host to sleep for the maximum amount of time, dramatically reducing system current consumption.

Adaptive Frequency Hopping

The BCM4334 gathers link quality statistics on a channel by channel basis to facilitate channel assessment and channel map selection. The link quality is determined using both RF and baseband signal processing to provide a more accurate frequency-hop map.

Not Recommended for New Designs

Advanced Bluetooth/WLAN Coexistence

The BCM4334 includes advanced coexistence technologies that are only possible with a Bluetooth/WLAN integrated die solution. These coexistence technologies are targeted at small form-factor platforms, such as cell phones and media players, including applications such as VoWLAN + SCO and Video-over-WLAN + High Fidelity BT Stereo.

Support is provided for platforms that share a single antenna between Bluetooth and WLAN. Dual-antenna applications are also supported. The BCM4334 radio architecture allows for lossless simultaneous Bluetooth and WLAN reception for shared antenna applications. This is possible only via an integrated solution (shared LNA and joint AGC algorithm). It has superior performance versus implementations that need to arbitrate between Bluetooth and WLAN reception.

The BCM4334 integrated solution enables MAC-layer signaling (firmware) and a greater degree of sharing via an enhanced coexistence interface. Information is exchanged between the Bluetooth and WLAN cores without host processor involvement.

The BCM4334 also supports Transmit Power Control on the STA together with standard Bluetooth TPC to limit mutual interference and receiver desensitization. Preemption mechanisms are utilized to prevent AP transmissions from colliding with Bluetooth frames. Improved channel classification techniques have been implemented in Bluetooth for faster and more accurate detection and elimination of interferers (including non-WLAN 2.4 GHz interference).

The Bluetooth AFH classification is also enhanced by the WLAN core's channel information.

Fast Connection (Interlaced Page and Inquiry Scans)

The BCM4334 supports page scan and inquiry scan modes that significantly reduce the average inquiry response and connection times. These scanning modes are compatible with the Bluetooth version 2.1 page and inquiry procedures.

Not Recommended for New Designs

Section 6: Music and Audio

The BCM4334 provides superior total system current during music or audio playback and recording. To enable these functions, several features of the device are combined to provide superior system power consumption.

MP3 Encoder

- ISO/IEC 11172-3 compliant
- Supports 32 kHz sampling frequencies only
- Encodes mono and stereo signals

MP3 Decoder

The MP3 decoder supports mono and stereo audio recording with the following specifications:

- Supports MPEG-1 Layer 3 decoding
- Output is fully bit compliant with MPEG-1 standard specification
- Supports sampling frequencies from 32 kHz to 48 kHz
- Minimum bit-rate supported 32 kbps and maximum bit-rate supported 320 kbps for Layer 3

AAC Decoder

Compliant to ISO/IEC 14496-3: 2004 specifications:

- MPEG-2, MPEG-4 AAC LC decoding up to level 2
- SBR tool, up to level 3
- Low power SBR tool
- Full support up to level 3 for the HE AAC profile
- Implicit and explicit SBR signaling mechanisms
- Mono and stereo channel streams decoding sampling frequencies from 8 kHz to 96 kHz only
- ADTS frame decoding

Not Recommended for New Designs

Section 7: Microprocessor and Memory Unit for Bluetooth

The Bluetooth microprocessor core is based on the ARM® Cortex-M3™ 32-bit RISC processor with embedded ICE-RT debug and JTAG interface units. It runs software from the link control (LC) layer, up to the host controller interface (HCI).

The ARM core is paired with a memory unit that contains 680 KB of ROM memory for program storage and boot ROM, 173 KB of RAM for data scratchpad and patch RAM code. The internal ROM allows for flexibility during power-on reset to enable the same device to be used in various configurations. At power-up, the lower-layer protocol stack is executed from the internal ROM memory.

External patches may be applied to the ROM-based firmware to provide flexibility for bug fixes or features additions. These patches may be downloaded from the host to the BCM4334 through the UART transports. The mechanism for downloading via UART is identical to the proven interface of the BCM4329 and BCM4330 devices.

RAM, ROM, and Patch Memory

The BCM4334 Bluetooth core has 173 KB of internal RAM which is mapped between general purpose scratch pad memory and patch memory and 680 KB of ROM used for the lower-layer protocol stack, test mode software, and boot ROM. The patch memory capability enables the addition of code changes for purposes of feature additions and bug fixes to the ROM memory.

Reset

The BCM4334 has an integrated power-on reset circuit that resets all circuits to a known power-on state. The BT power-on reset (POR) circuit is out of reset after BT_REG_ON goes High. If BT_REG_ON is low, then the POR circuit is held in reset.

Not Recommended for New Designs

Section 8: Bluetooth Peripheral Transport Unit

SPI Interface and Transport Selection

The BCM4334 supports a slave SPI HCI transport with an input clock of up to 16 MHz, although higher clock rates may be possible. The physical interface between the SPI master and the BCM4334 contains four SPI signals (SPI_CSB, SPI_CLK, SPI_MOSI, and SPI_MISO) and one interrupt signal (SPI_INT). The BCM4334 can be configured to accept active-low or active-high polarity on the SPI_CSB chip select signal. It can also be configured to drive an active-low or active-high SPI_INT interrupt signal.

The following additional details apply to the SPI interface:

- Bit ordering on the SPI_MOSI and SPI_MISO data lines can be configured as either little endian or big endian.
- Proprietary sleep mode, half-duplex handshaking is implemented between the SPI master and the BCM4334.
- SPI_INT is required to negotiate the start of a transaction.
- The SPI interface does not require flow control in the middle of a payload.
- The FIFO is large enough to handle the largest packet size.
- Only the SPI master can stop the flow of bytes on the data lines because it controls SPI_CSB and SPI_CLK.
- Flow control should be implemented in higher layer protocols.

The SPI signals are multiplexed onto the UART signals as shown in [Table 5](#). See “[UART Interface](#)” on page 58 for more information on the UART interface.

Table 5: SPI and UART Signal Multiplexing

<i>SPI Signal</i>	<i>UART Signal</i>
SPI_CLK	UART_CTS_N
SPI_CSB	UART_RTS_N
SPI_MISO	UART_RXD
SPI_MOSI	UART_TXD
SPI_INT	BT_HOST_WAKE

The Bluetooth HCI transport interface (which will be either SPI or UART) is selected during power-up per the state of the BT_HOST_WAKE (BT_GPIO_1) signal (listed in [Table 5](#) as a UART signal). Transport interface selection is as follows:

- If the BT_HOST_WAKE signal is low during power-up, then the SPI transport interface will be selected.
- If the BT_HOST_WAKE signal is not low during power-up, then the UART transport interface will be selected.



Note: BT_HOST_WAKE is pulled up in the device. Attach it to an external pull-down to select the SPI as the transport interface.

PCM Interface

The BCM4334 supports two independent PCM interfaces that share the pins with the I²S interfaces. The PCM Interface on the BCM4334 can connect to linear PCM Codec devices in master or slave mode. In master mode, the BCM4334 generates the PCM_CLK and PCM_SYNC signals, and in slave mode, these signals are provided by another master on the PCM interface and are inputs to the BCM4334.

The configuration of the PCM interface may be adjusted by the host through the use of vendor-specific HCI commands.

Slot Mapping

The BCM4334 supports up to three simultaneous full-duplex SCO or eSCO channels through the PCM interface. These three channels are time-multiplexed onto the single PCM interface by using a time-slotting scheme where the 8 kHz or 16 kHz audio sample interval is divided into as many as 16 slots. The number of slots is dependent on the selected interface rate of 128 kHz, 512 kHz, or 1024 kHz. The corresponding number of slots for these interface rate is 1, 2, 4, 8, and 16, respectively. Transmit and receive PCM data from an SCO channel is always mapped to the same slot. The PCM data output driver tri-states its output on unused slots to allow other devices to share the same PCM interface signals. The data output driver tri-states its output after the falling edge of the PCM clock during the last bit of the slot.

Frame Synchronization

The BCM4334 supports both short- and long-frame synchronization in both master and slave modes. In short-frame synchronization mode, the frame synchronization signal is an active-high pulse at the audio frame rate that is a single-bit period in width and is synchronized to the rising edge of the bit clock. The PCM slave looks for a high on the falling edge of the bit clock and expects the first bit of the first slot to start at the next rising edge of the clock. In long-frame synchronization mode, the frame synchronization signal is again an active-high pulse at the audio frame rate; however, the duration is three bit periods and the pulse starts coincident with the first bit of the first slot.

Data Formatting

The BCM4334 may be configured to generate and accept several different data formats. For conventional narrowband speech mode, the BCM4334 uses 13 of the 16 bits in each PCM frame. The location and order of these 13 bits can be configured to support various data formats on the PCM interface. The remaining three bits are ignored on the input and may be filled with 0s, 1s, a sign bit, or a programmed value on the output. The default format is 13-bit 2's complement data, left justified, and clocked MSB first.

Not Recommended for New Designs

Wideband Speech Support

When the host encodes Wideband Speech (WBS) packets in transparent mode, the encoded packets are transferred over the PCM bus for an eSCO voice connection. In this mode, the PCM bus is typically configured in master mode for a 4 kHz sync rate with 16-bit samples, resulting in a 64 kbps bit rate. The BCM4334 also supports slave transparent mode using a proprietary rate-matching scheme. In SBC-code mode, linear 16-bit data at 16 kHz (256 kbps rate) is transferred over the PCM bus.

Burst PCM Mode

In this mode of operation, the PCM bus runs at a significantly higher rate of operation to allow the host to duty cycle its operation and save current. In this mode of operation, the PCM bus can operate at a rate of up to 24 MHz. This mode of operation is initiated with an HCI command from the host.

Not Recommended for New Designs

PCM Interface Timing

Short Frame Sync, Master Mode

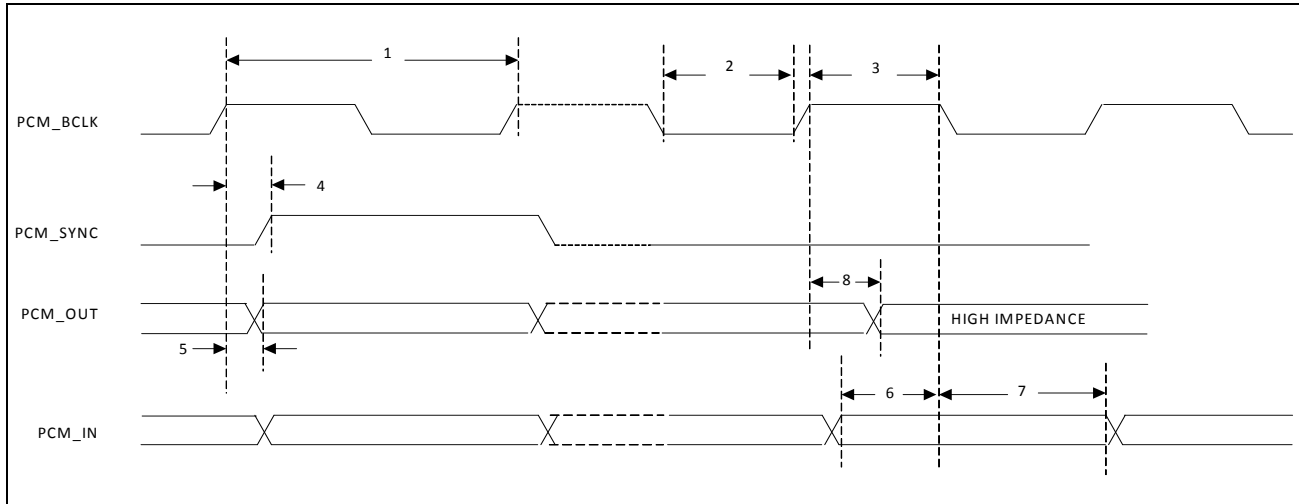

Figure 11: PCM Timing Diagram (Short Frame Sync, Master Mode)

Table 6: PCM Interface Timing Specifications (Short Frame Sync, Master Mode)

Ref No.	Characteristics	Minimum	Typical	Maximum	Unit
1	PCM bit clock frequency	–	–	12	MHz
2	PCM bit clock low	41	–	–	ns
3	PCM bit clock high	41	–	–	ns
4	PCM_SYNC delay	0	–	25	ns
5	PCM_OUT delay	0	–	25	ns
6	PCM_IN setup	8	–	–	ns
7	PCM_IN hold	8	–	–	ns
8	Delay from rising edge of PCM_BCLK during last bit period to PCM_OUT becoming high impedance	0	–	25	ns

Not Recommended for New Designs

Short Frame Sync, Slave Mode

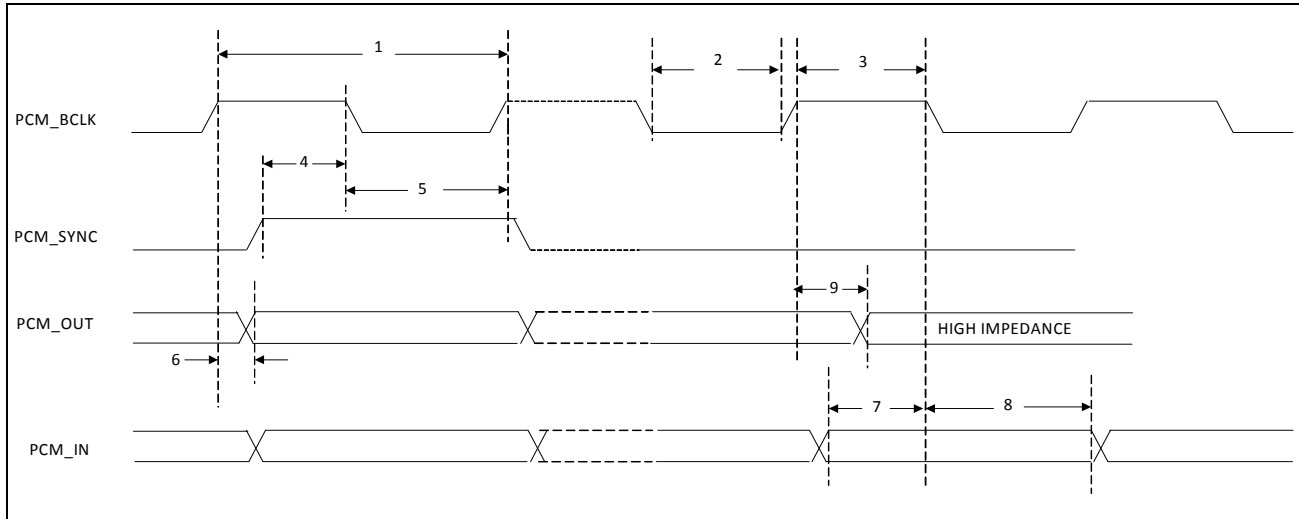

Figure 12: PCM Timing Diagram (Short Frame Sync, Slave Mode)

Table 7: PCM Interface Timing Specifications (Short Frame Sync, Slave Mode)

Ref No.	Characteristics	Minimum	Typical	Maximum	Unit
1	PCM bit clock frequency	–	–	12	MHz
2	PCM bit clock low	41	–	–	ns
3	PCM bit clock high	41	–	–	ns
4	PCM_SYNC setup	8	–	–	ns
5	PCM_SYNC hold	8	–	–	ns
6	PCM_OUT delay	0	–	25	ns
7	PCM_IN setup	8	–	–	ns
8	PCM_IN hold	8	–	–	ns
9	Delay from rising edge of PCM_BCLK during last bit period to PCM_OUT becoming high impedance	0	–	25	ns

Not Recommended for New Designs

Long Frame Sync, Master Mode

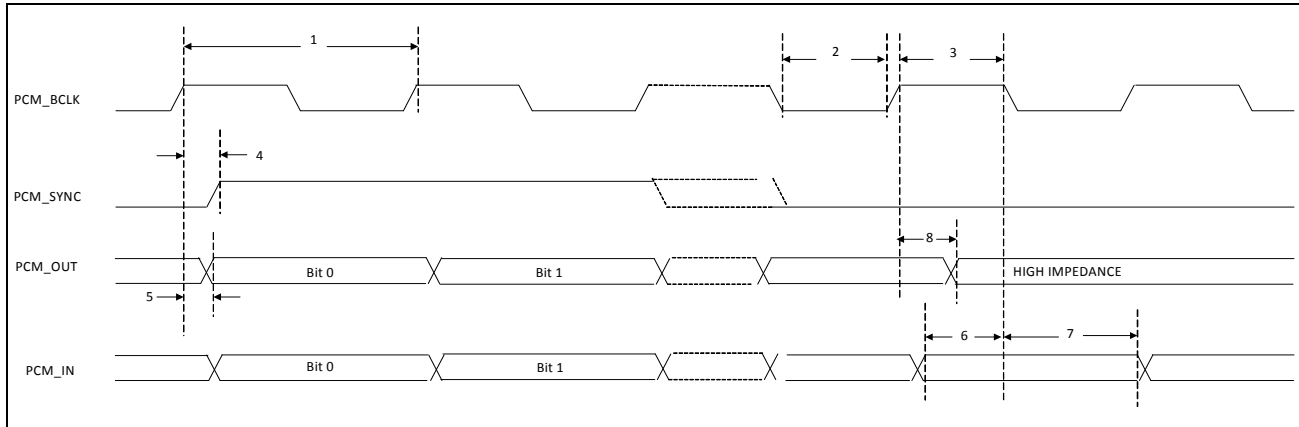

Figure 13: PCM Timing Diagram (Long Frame Sync, Master Mode)

Table 8: PCM Interface Timing Specifications (Long Frame Sync, Master Mode)

Ref No.	Characteristics	Minimum	Typical	Maximum	Unit
1	PCM bit clock frequency	–	–	12	MHz
2	PCM bit clock low	41	–	–	ns
3	PCM bit clock high	41	–	–	ns
4	PCM_SYNC delay	0	–	25	ns
5	PCM_OUT delay	0	–	25	ns
6	PCM_IN setup	8	–	–	ns
7	PCM_IN hold	8	–	–	ns
8	Delay from rising edge of PCM_BCLK during last bit period to PCM_OUT becoming high impedance	0	–	25	ns

Not Recommended for New Designs

Long Frame Sync, Slave Mode

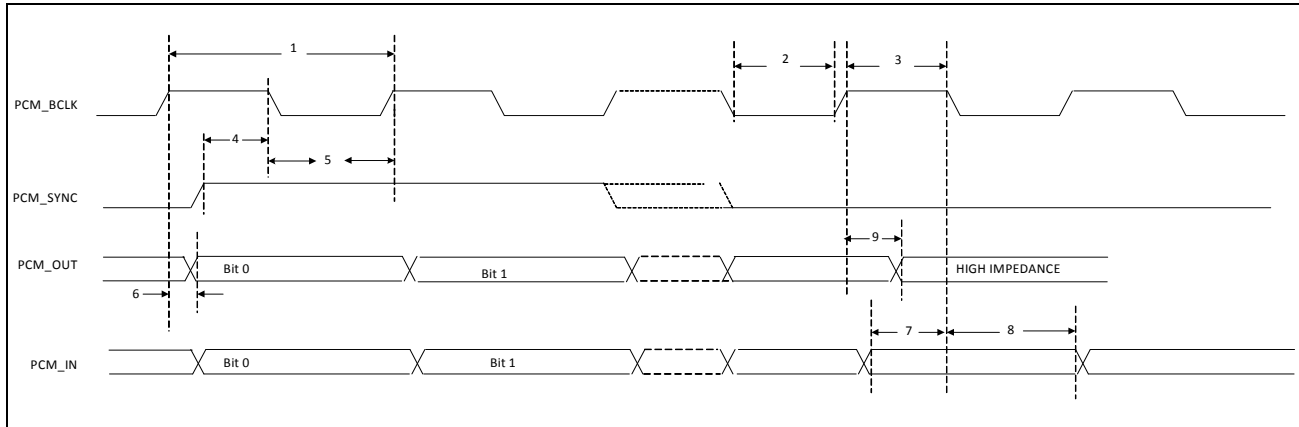

Figure 14: PCM Timing Diagram (Long Frame Sync, Slave Mode)

Table 9: PCM Interface Timing Specifications (Long Frame Sync, Slave Mode)

Ref No.	Characteristics	Minimum	Typical	Maximum	Unit
1	PCM bit clock frequency	–	–	12	MHz
2	PCM bit clock low	41	–	–	ns
3	PCM bit clock high	41	–	–	ns
4	PCM_SYNC setup	8	–	–	ns
5	PCM_SYNC hold	8	–	–	ns
6	PCM_OUT delay	0	–	25	ns
7	PCM_IN setup	8	–	–	ns
8	PCM_IN hold	8	–	–	ns
9	Delay from rising edge of PCM_BCLK during last bit period to PCM_OUT becoming high impedance	0	–	25	ns

Not Recommended for New Designs

Short Frame Sync, Burst Mode

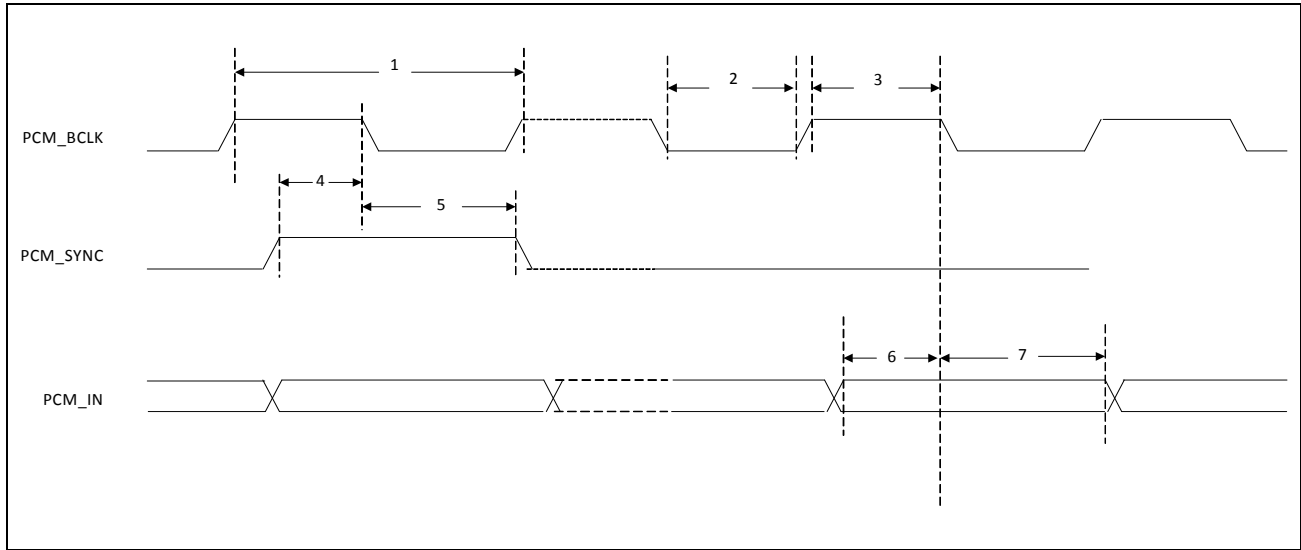

Figure 15: PCM Burst Mode Timing (Receive Only, Short Frame Sync)

Table 10: PCM Burst Mode (Receive Only, Short Frame Sync)

Ref No.	Characteristics	Minimum	Typical	Maximum	Unit
1	PCM bit clock frequency	–	–	24	MHz
2	PCM bit clock low	20.8	–	–	ns
3	PCM bit clock high	20.8	–	–	ns
4	PCM_SYNC setup	8	–	–	ns
5	PCM_SYNC hold	8	–	–	ns
6	PCM_IN setup	8	–	–	ns
7	PCM_IN hold	8	–	–	ns

Not Recommended for New Designs

Long Frame Sync, Burst Mode

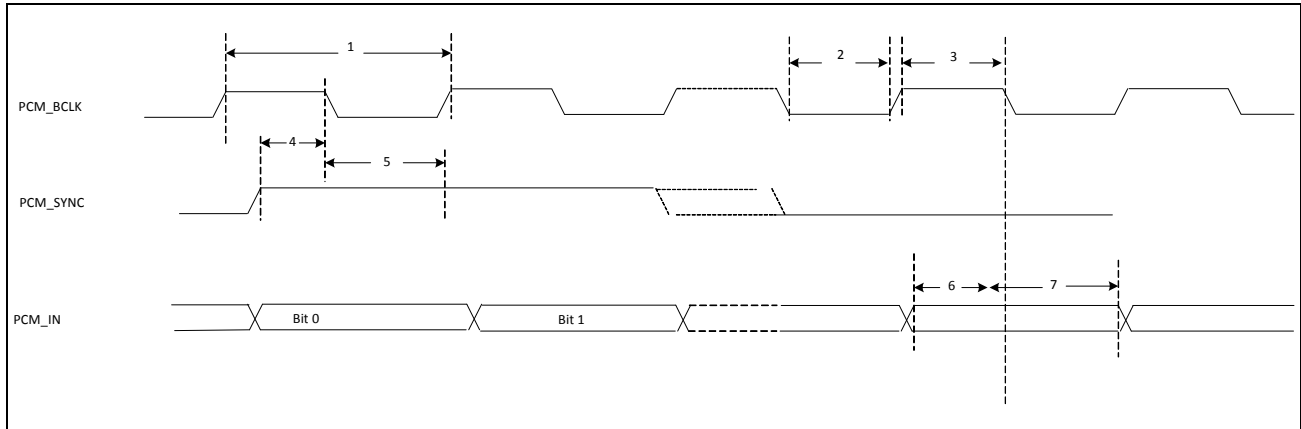

Figure 16: PCM Burst Mode Timing (Receive Only, Long Frame Sync)

Table 11: PCM Burst Mode (Receive Only, Long Frame Sync)

Ref No.	Characteristics	Minimum	Typical	Maximum	Unit
1	PCM bit clock frequency	–	–	24	MHz
2	PCM bit clock low	20.8	–	–	ns
3	PCM bit clock high	20.8	–	–	ns
4	PCM_SYNC setup	8	–	–	ns
5	PCM_SYNC hold	8	–	–	ns
6	PCM_IN setup	8	–	–	ns
7	PCM_IN hold	8	–	–	ns

Not Recommended for New Designs

UART Interface

The BCM4334 shares a single UART for Bluetooth and FM. The UART is a standard 4-wire interface (RX, TX, RTS, and CTS) with adjustable baud rates from 9600 bps to 4.0 Mbps. The interface features an automatic baud rate detection capability that returns a baud rate selection. Alternatively, the baud rate may be selected through a vendor-specific UART HCI command.

UART has a 1040-byte receive FIFO and a 1040-byte transmit FIFO to support EDR. Access to the FIFOs is conducted through the AHB interface through either DMA or the CPU. The UART supports the Bluetooth 4.0 UART HCI specification: H4, a custom Extended H4, and H5. The default baud rate is 115.2 Kbaud.

The UART supports the 3-wire H5 UART transport, as described in the Bluetooth specification (“Three-wire UART Transport Layer”). Compared to H4, the H5 UART transport reduces the number of signal lines required by eliminating the CTS and RTS signals.

The BCM4334 UART can perform XON/XOFF flow control and includes hardware support for the Serial Line Input Protocol (SLIP). It can also perform wake-on activity. For example, activity on the RX or CTS inputs can wake the chip from a sleep state.

Normally, the UART baud rate is set by a configuration record downloaded after device reset, or by automatic baud rate detection, and the host does not need to adjust the baud rate. Support for changing the baud rate during normal HCI UART operation is included through a vendor-specific command that allows the host to adjust the contents of the baud rate registers. The BCM4334 UARTs operate correctly with the host UART as long as the combined baud rate error of the two devices is within $\pm 2\%$.

Table 12: Example of Common Baud Rates

Desired Rate	Actual Rate	Error (%)
4000000	4000000	0.00
3692000	3692308	0.01
3000000	3000000	0.00
2000000	2000000	0.00
1500000	1500000	0.00
1444444	1454544	0.70
921600	923077	0.16
460800	461538	0.16
230400	230796	0.17
115200	115385	0.16
57600	57692	0.16
38400	38400	0.00
28800	28846	0.16
19200	19200	0.00
14400	14423	0.16
9600	9600	0.00

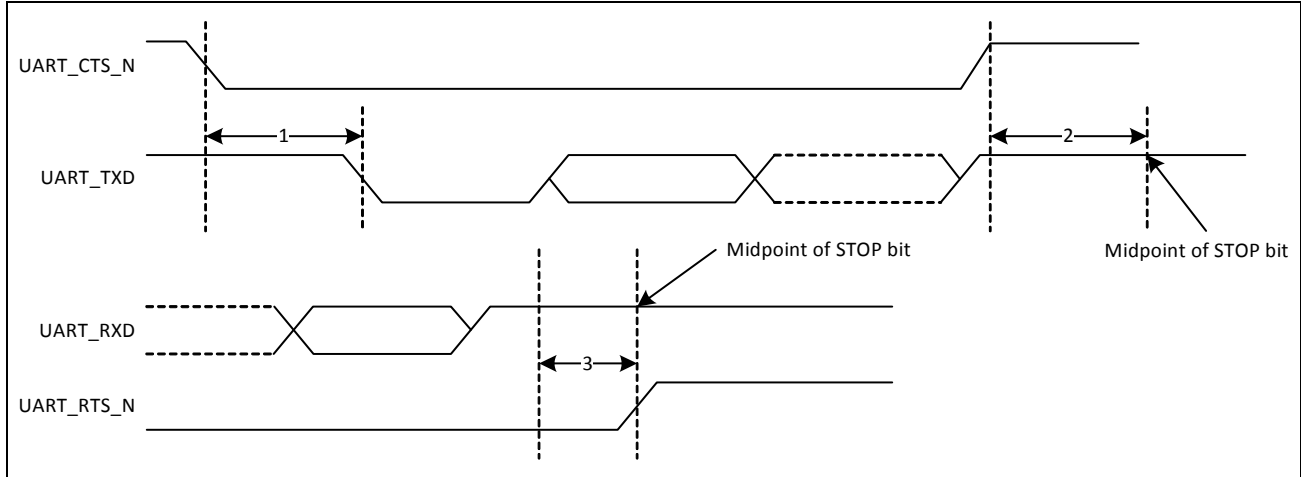

Figure 17: UART Timing

Table 13: UART Timing Specifications

Ref No.	Characteristics	Minimum	Typical	Maximum	Unit
1	Delay time, UART_CTS_N low to UART_TXD valid	–	–	1.5	Bit periods
2	Setup time, UART_CTS_N high before midpoint of stop bit	–	–	0.5	Bit periods
3	Delay time, midpoint of stop bit to UART_RTS_N high	–	–	0.5	Bit periods

Not Recommended for New Designs

I²S Interface

The BCM4334 supports two independent I²S digital audio ports: one for Bluetooth audio, and one for high-fidelity FM audio. The I²S interface for FM audio supports both master and slave modes. The I²S signals are:

- I²S clock: I²S SCK
- I²S Word Select: I²S WS
- I²S Data Out: I²S SDO
- I²S Data In: I²S SDI

I²S SCK and I²S WS become outputs in master mode and inputs in slave mode, while I²S SDO always stays as an output. The channel word length is 16 bits and the data is justified so that the MSB of the left-channel data is aligned with the MSB of the I²S bus, per the I²S specification. The MSB of each data word is transmitted one bit clock cycle after the I²S WS transition, synchronous with the falling edge of bit clock. Left-channel data is transmitted when I²S WS is low, and right-channel data is transmitted when I²S WS is high. Data bits sent by the BCM4334 are synchronized with the falling edge of I2S_SCK and should be sampled by the receiver on the rising edge of I2S_SSCK.

The clock rate in master mode is either of the following:

48 kHz x 32 bits per frame = 1.536 MHz

48 kHz x 50 bits per frame = 2.400 MHz

The master clock is generated from the input reference clock using a N/M clock divider.

In the slave mode, any clock rate is supported to a maximum of 3.072 MHz.

I²S Timing



Note: Timing values specified in [Table 14](#) are relative to high and low threshold levels.

Table 14: Timing for I²S Transmitters and Receivers

	<i>Transmitter</i>				<i>Receiver</i>				<i>Notes</i>
	<i>Lower Limit</i>		<i>Upper Limit</i>		<i>Lower Limit</i>		<i>Upper Limit</i>		
	<i>Min</i>	<i>Max</i>	<i>Min</i>	<i>Max</i>	<i>Min</i>	<i>Max</i>	<i>Min</i>	<i>Max</i>	
Clock Period T	T_{tr}	–	–	–	T_r	–	–	–	1
Master Mode: Clock generated by transmitter or receiver									
High t_{HC}	$0.35T_{tr}$	–	–	–	$0.35T_{tr}$	–	–	–	2
Low t_{LC}	$0.35T_{tr}$	–	–	–	$0.35T_{tr}$	–	–	–	2
Slave Mode: Clock accepted by transmitter or receiver									
High t_{HC}	–	$0.35T_{tr}$	–	–	–	$0.35T_{tr}$	–	–	3
Low t_{LC}	–	$0.35T_{tr}$	–	–	–	$0.35T_{tr}$	–	–	3
Rise time t_{RC}	–	–	$0.15T_{tr}$	–	–	–	–	–	4
Transmitter									
Delay t_{dtr}	–	–	–	$0.8T$	–	–	–	–	5
Hold time t_{htr}	0	–	–	–	–	–	–	–	4
Receiver									
Setup time t_{sr}	–	–	–	–	–	$0.2T_r$	–	–	6
Hold time t_{hr}	–	–	–	–	–	0	–	–	6

**Note:**

- The system clock period T must be greater than T_{tr} and T_r because both the transmitter and receiver have to be able to handle the data transfer rate.
- At all data rates in master mode, the transmitter or receiver generates a clock signal with a fixed mark/space ratio. For this reason, t_{HC} and t_{LC} are specified with respect to T.
- In slave mode, the transmitter and receiver need a clock signal with minimum high and low periods so that they can detect the signal. So long as the minimum periods are greater than $0.35T_r$, any clock that meets the requirements can be used.
- Because the delay (t_{dtr}) and the maximum transmitter speed (defined by T_{tr}) are related, a fast transmitter driven by a slow clock edge can result in t_{dtr} not exceeding t_{RC} which means t_{htr} becomes zero or negative. Therefore, the transmitter has to guarantee that t_{htr} is greater than or equal to zero, so long as the clock rise-time t_{RC} is not more than t_{RCmax} , where t_{RCmax} is not less than $0.15T_{tr}$.
- To allow data to be clocked out on a falling edge, the delay is specified with respect to the rising edge of the clock signal and T, always giving the receiver sufficient setup time.
- The data setup and hold time must not be less than the specified receiver setup and hold time.



Note: The time periods specified in Figure 18 and Figure 19 are defined by the transmitter speed. The receiver specifications must match transmitter performance.

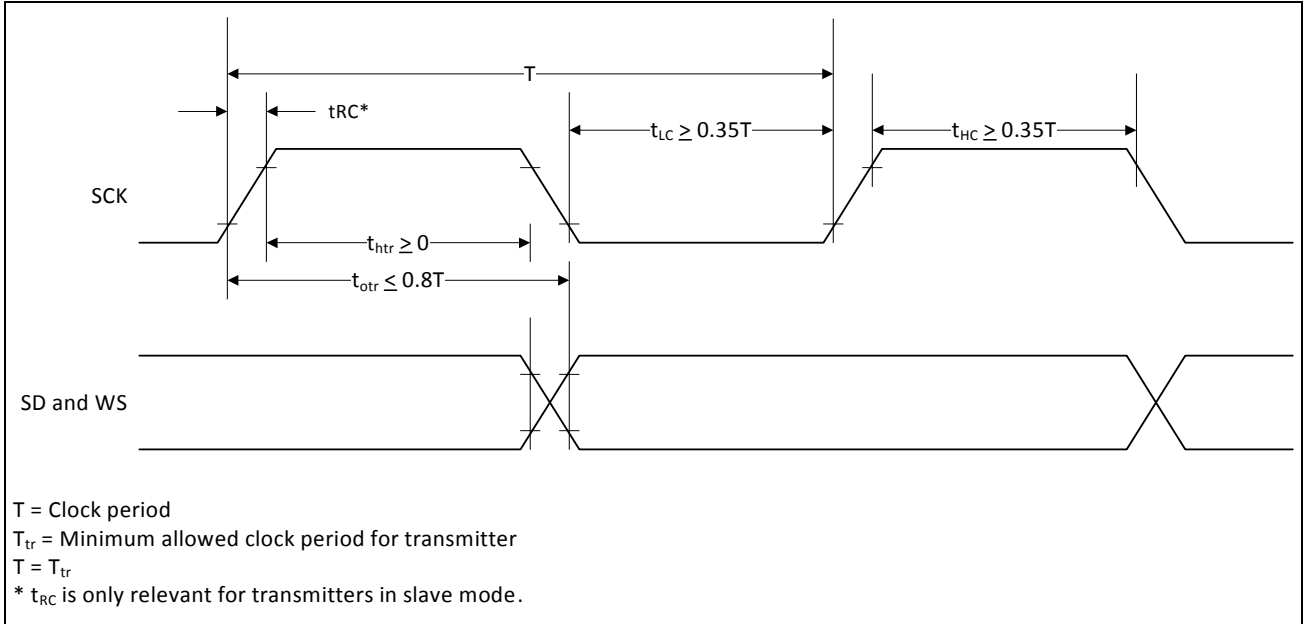

Figure 18: I²S Transmitter Timing

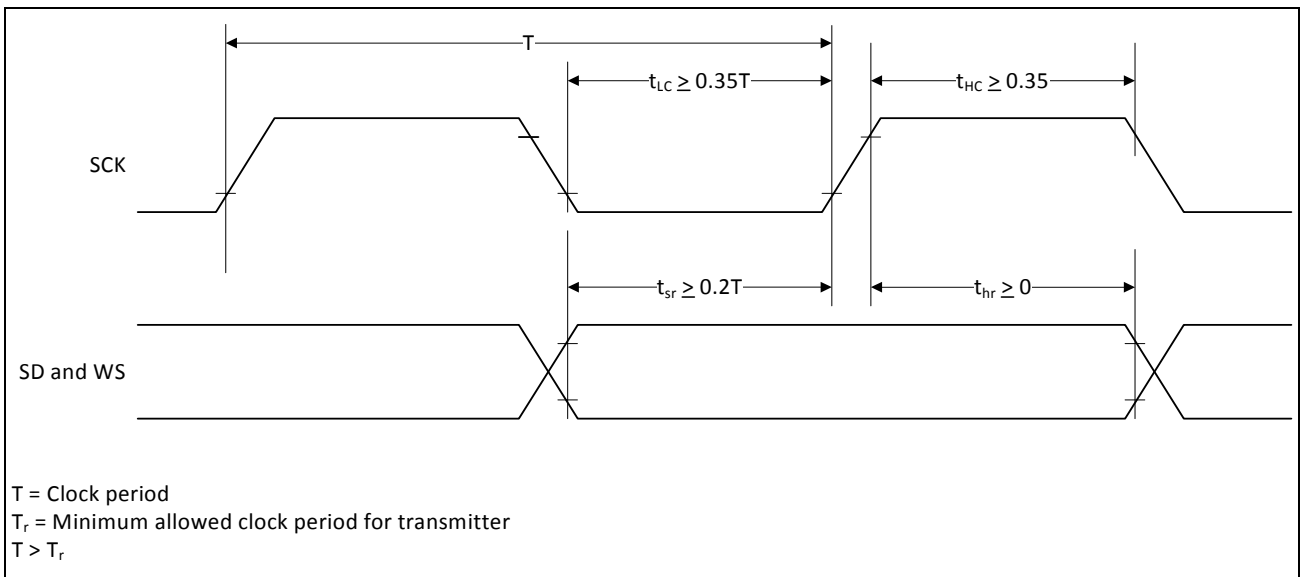

Figure 19: I²S Receiver Timing

Not Recommended for New Designs

Section 9: FM Receiver Subsystem

FM Radio

The BCM4334 includes a completely integrated FM radio receiver with RDS/RBDS covering all FM bands from 65 MHz to 108 MHz. The receiver is controlled through commands on the HCI. FM received audio is available in digital form through I²S or PCM. The FM radio operates from the external clock reference.

Digital FM Audio Interfaces

The FM audio can be transmitted via the shared PCM and I²S pins, and the sampling rate is programmable. The BCM4334 supports a three-wire PCM or I²S audio interface in either master or slave configuration. The master or slave configuration is selected using vendor specific commands over the HCI interface. In addition, multiple sampling rates are supported, derived from either the FM or Bluetooth clocks. In master mode, the clock rate is either of the following:

- 48 kHz x 32 bits per frame = 1.536 MHz
- 48 kHz x 50 bits per frame = 2.400 MHz

In slave mode, any clock rate is supported up to a maximum of 3.072 MHz.

FM Over Bluetooth

The BCM4334 can output received FM audio onto Bluetooth using one of following three links: eSCO, WBS, and A2DP. In all of the above modes, once the link has been set up, the host processor can enter sleep mode while the BCM4334 continues to stream FM audio to the remote Bluetooth device, allowing the system current consumption to be minimized.

eSCO

In this use case, the stereo FM audio is downsampled to 8 kHz and a mono or stereo stream is then sent through the Bluetooth eSCO link to a remote Bluetooth device, typically a headset. Two Bluetooth voice connections must be used to transport stereo.

Not Recommended for New Designs

Wide Band Speech Link

In this case, the stereo FM audio is downsampled to 16 kHz and a mono or stereo stream is then sent through the Bluetooth wideband speech link to a remote Bluetooth device, typically a headset. Two Bluetooth voice connections must be used to transport stereo.

A2DP

In this case, the stereo FM audio is encoded by the on-chip SBC encoder and transported as an A2DP link to a remote Bluetooth device. Sampling rates of 48 kHz, 44.1 kHz, and 32 kHz joint stereo are supported. An A2DP lite stack is implemented in the BCM4334 to support this use case, which eliminates the need to route the SBC-encoded audio back to the host to create the A2DP packets.

Autotune and Search Algorithms

The BCM4334 supports a number of FM search and tune functions that allows the host to implement many convenient user functions, which are accessed through the Broadcom FM stack.

- Tune to Play— Allows the FM receiver to be programmed to a specific frequency.
- Search for SNR > Threshold— Checks the power level of the available channel and the estimated SNR of the channel to help achieve precise control of the expected sound quality for the selected FM channel. Specifically, the host can adjust its SNR requirements to retrieve a signal with a specific sound quality, or adjust this to return the weakest channels.
- Alternate Frequency Jump— Allows the FM receiver to automatically jump to an alternate FM channel that carries the same information, but has a better SNR. For example, when traveling, a user may pass through a region where a number of channels carry the same station. When the user passes from one area to the next, the FM receiver can automatically switch to another channel with a stronger signal to spare the user from having to manually change the channel to continue listening to the same station.

Audio Features

A number of features are implemented in the BCM4334 to provide the best possible audio experience for the user.

- Mono/Stereo Blend or Switch — The BCM4334 provides automatic control of the stereo or mono settings based on the FM signal carrier-to-noise ratio (C/N). This feature is used to maintain the best possible audio SNR based on the FM channel condition. Two modes of operation are supported:
 - Blend — In this mode, fine control of stereo separation is used to achieve optimal audio quality over a wide range of input C/N. The amount of separation is fully programmable. In Figure 20, the separation is programmed to maintain a minimum 50 dB SNR across the blend range.
 - Switch — In this mode, the audio switches from full stereo to full mono at a predetermined level to maintain optimal audio quality. The stereo-to-mono switch point and the mono-to-stereo switch points are fully programmable to provide the desired amount of audio SNR. In Figure 21, the switch point is programmed to switch to mono to maintain a 40 dB SNR.

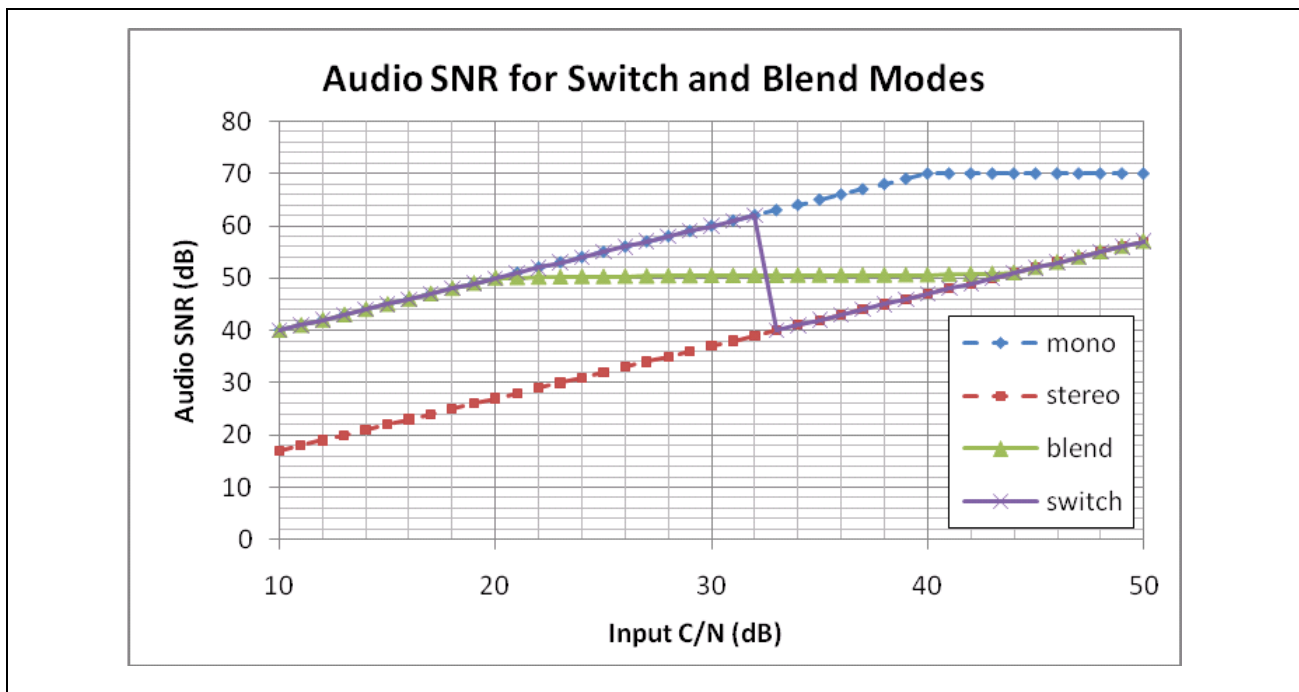

Figure 20: Example Blend/Switch Usage

Not Recommended for New Designs

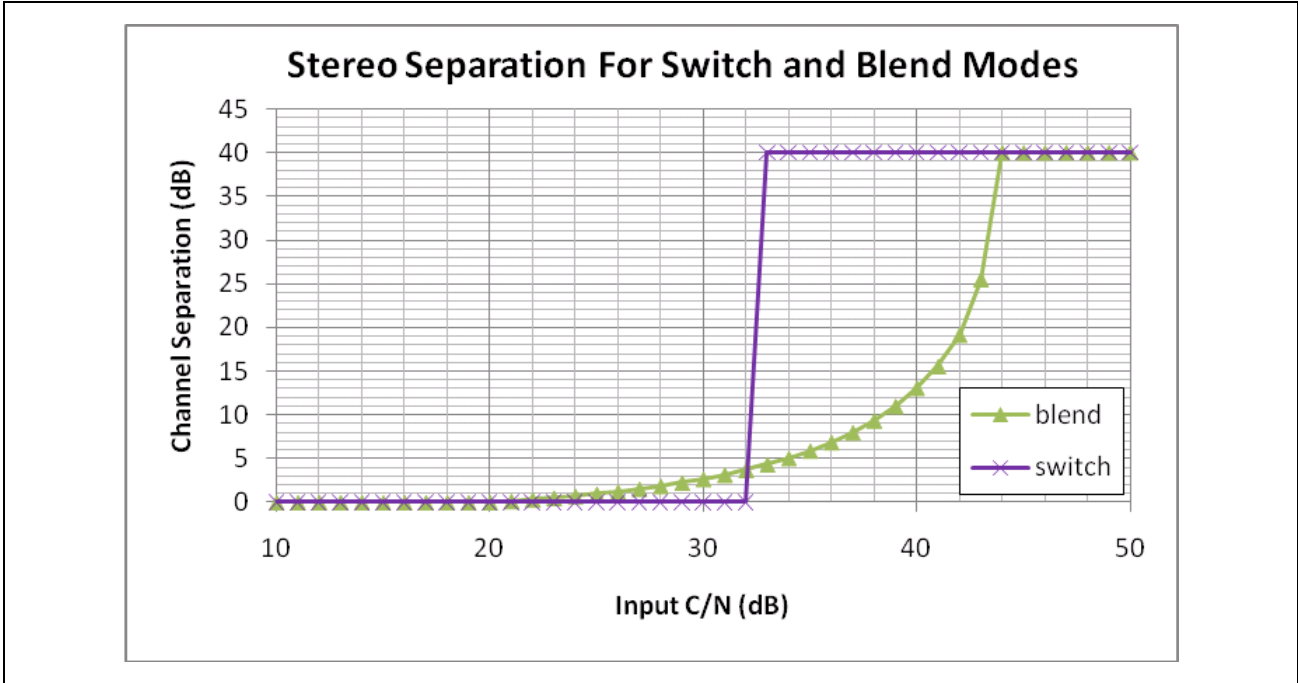

Figure 21: Example Blend/Switch Separation

- Soft Mute — Improves the user experience by dynamically muting the output audio proportionate to the FM signal C/N. This prevents the user from being assaulted with a blast of static. The mute characteristic is fully programmable to accommodate fine tuning of the output signal level. An example mute characteristic is shown in [Figure 22](#).

Not Recommended for New Designs

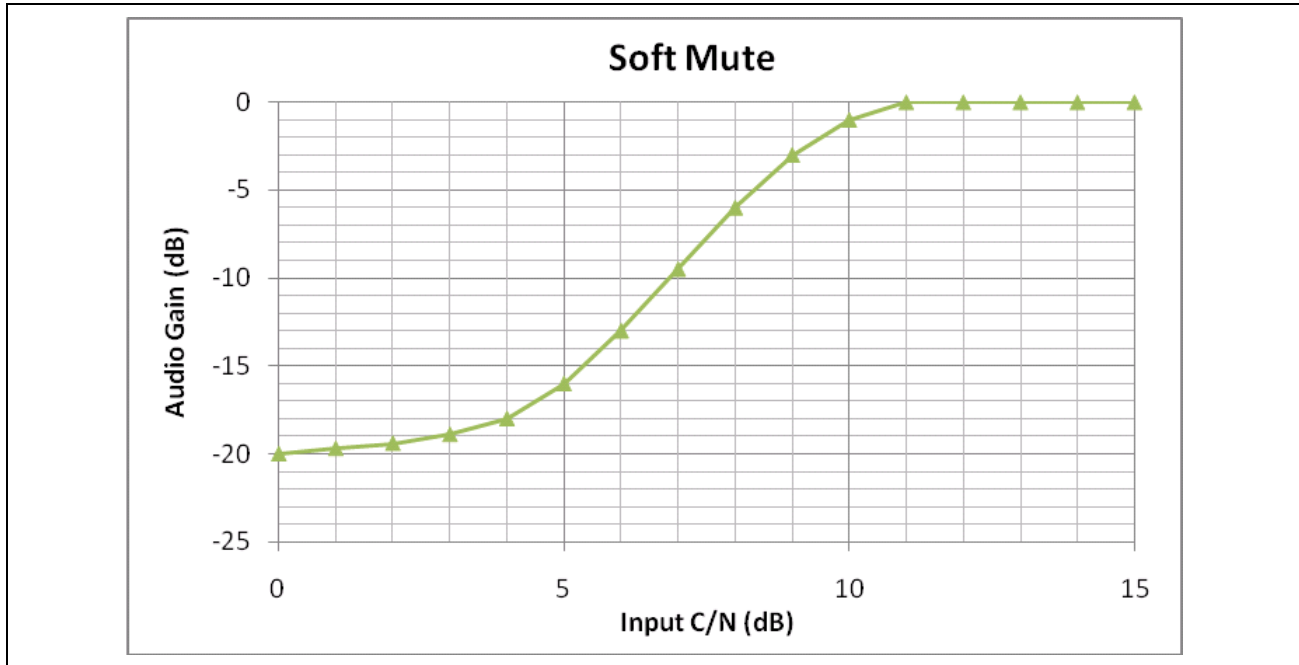

Figure 22: Example Soft Mute Characteristic

- High Cut — A programmable high-cut filter is provided to reduce the amount of high-frequency noise caused by static in the output audio signal. Like the soft mute circuit, it is fully programmable to allow for any amount of high cut based on the FM signal C/N.
- Audio Pause Detect — The FM receiver monitors the magnitude of the audio signal and notifies the host through an interrupt when the magnitude of the signal has fallen below the threshold set for a programmable period. This feature can be used to provide alternate frequency jumps during periods of silence to minimize disturbances to the listener. Filtering techniques are used within the audio pause detection block to provide more robust presence-to-silence detection and silence-to-presence detection.
- Automatic Antenna Tuning — The BCM4334 has an on-chip automatic antenna tuning network. When used with a single off-chip inductor, the on-chip circuitry automatically chooses an optimal on-chip matching component to obtain the highest signal strength for the desired frequency. The high-Q nature of this matching network simultaneously provides out-of-band blocking protection as well as a reduction of radiated spurious emissions from the FM antenna. It is designed to accommodate a wide range of external wire antennas.

On-Chip MP3 Encoding

In this mode of operation, the device can record the FM audio to MP3, then output the MP3 data over the HCI interface. The feature effectively offloads the MP3 recording processing load from the host and assists in FM time shift applications. This feature can also be used in conjunction with burst mode buffering to provide significant FM system record times.

Not Recommended for New Designs

RDS/RBDS

The BCM4334 integrates a RDS/RBDS modem and codec, the decoder includes programmable filtering and buffering functions, and the encoder includes the option to encode messages to PS or RT frame format with programmable scrolling in PS mode. The RDS/RBDS data can be read out in receive mode or delivered in transmit mode through either the HCI interface.

In addition, the RDS/RBDS functionality supports the following:

Receive

- Block decoding, error correction and synchronization
- Flywheel synchronization feature, allowing the host to set parameters for acquisition, maintenance, and loss of sync. (It is possible to set up the BCM4334 such that synch is achieved when a minimum of two good blocks (error free) are decoded in sequence. The number of good blocks required for sync is programmable.)
- Storage capability up to 126 blocks of RDS data
- Full or partial block B match detect and interrupt to host
- Audio pause detection with programmable parameters
- Program Identification (PI) code detection and interrupt to host
- Automatic frequency jump
- Block E filtering
- Soft mute
- Signal dependent mono/stereo blend
- Programmable pre-emphasis

Not Recommended for New Designs

Section 10: WLAN Global Functions

WLAN CPU and Memory Subsystem

The BCM4334 includes an integrated ARM Cortex-M3™ processor with internal RAM and ROM. The ARM Cortex-M3 processor is a low-power processor that features low gate count, low interrupt latency, and low-cost debug. It is intended for deeply embedded applications that require fast interrupt response features. The processor implements the ARM architecture v7-M with support for Thumb®-2 instruction set. ARM Cortex-M3 delivers 30% more performance gain over ARM7TDMI.

At 0.19 $\mu\text{W}/\text{MHz}$, the Cortex-M3 is the most power efficient general purpose microprocessor available, outperforming 8- and 16-bit devices on MIPS/ μW . It supports integrated sleep modes.

ARM Cortex-M3 uses multiple technologies to reduce cost through improved memory utilization, reduced pin overhead, and reduced silicon area. ARM Cortex-M3 supports independent buses for code and data access (Icode/Dcode and system buses). ARM Cortex-M3 supports extensive debug features including real time trace of program execution.

On-chip memory for the CPU includes 512 KB SRAM and 640 KB ROM.

One-Time Programmable Memory

Various hardware configuration parameters may be stored in an internal 3072-bit One-Time Programmable (OTP) memory, which is read by the system software after device reset. In addition, customer-specific parameters, including the system vendor ID and the MAC address can be stored, depending on the specific board design.

The initial state of all bits in an unprogrammed OTP device is 0. After any bit is programmed to a 1, it cannot be reprogrammed to 0. The entire OTP array can be programmed in a single write cycle using a utility provided with the Broadcom WLAN manufacturing test tools. Alternatively, multiple write cycles can be used to selectively program specific bytes, but only bits which are still in the 0 state can be altered during each programming cycle.

Prior to OTP programming, all values should be verified using the appropriate editable nvram.txt file, which is provided with the reference board design package.

Not Recommended for New Designs

GPIO Interface

On the WLCSP package, there are 16 general purpose I/O (GPIO) pins, and on the WLPGA package, there are 8 GPIO pins available on the WLAN section of the BCM4334 that can be used to connect to various external devices.

Upon power up and reset, these pins become tri-stated. Subsequently, they can be programmed to be either input or output pins through the GPIO control register.

External Coexistence Interface

An external handshake interface is available to enable signaling between the device and an external co-located wireless device, such as GPS, WiMAX, or UWB, to manage wireless medium sharing for optimum performance. The coexistence signals in [Table 15](#) can be enabled by software on the indicated GPIO pins.

Table 15: External Coexistence Interface

<i>Coexistence Signal</i>	<i>GPIO Name</i>	<i>Type</i>	<i>Comment</i>
ERCX_STATUS	WL_GPIO_2	Input	For synchronization with an external coexisting device.
ERCX_FREQ	WL_GPIO_3	Input	–
ERCX_RF_ACTIVE	WL_GPIO_4	Input	To be asserted by an external coexisting device when it becomes active.
ERCX_TXCONF	WL_GPIO_5	Output	Asserted by the WLAN to request priority.
ERCX_PRISEL	WL_GPIO_12	Output	–

UART Interface

One UART interface can be enabled by software as an alternate function on pins WL_GPIO_4 and WL_GPIO_5. Provided primarily for debugging during development, this UART enables the BCM4334 to operate as RS-232 data termination equipment (DTE) for exchanging and managing data with other serial devices. It is compatible with the industry standard 16550 UART and provides a FIFO size of 64 × 8 in each direction.

JTAG Interface

The BCM4334 supports the IEEE 1149.1 JTAG boundary scan standard for performing device package and PCB assembly testing during manufacturing. In addition, the JTAG interface allows Broadcom to assist customers by using proprietary debug and characterization test tools during board bring-up. Therefore, it is highly recommended to provide access to the JTAG pins by means of test points or a header on all PCB designs.

Section 11: WLAN Host Interfaces

SDIO v2.0

The BCM4334 WLAN section supports SDIO version 2.0, including the following modes:

- DS: Default speed up to 25 MHz, including 1- and 4-bit modes
 HS: High speed up to 50 MHz

It also has the ability to map the interrupt signal onto a GPIO pin for applications requiring an interrupt different than what is provided by the SDIO interface. The ability to force control of the gated clocks from within the device is also provided. SDIO mode is enabled using the strapping option pins strap_host_ifc_[3:1] ([Table 21: “WLAN GPIO Functions and Strapping Options \(Advance Information\),” on page 106](#)).

Three functions are supported:

- Function 0 standard SDIO function (Max BlockSize/ByteCount = 32B)
- Function 1 backplane function to access the internal system-on-chip (SoC) address space (Max BlockSize/ByteCount = 64B)
- Function 2 WLAN function for efficient WLAN packet transfer through DMA (Max BlockSize/ByteCount = 512B)

SDIO Pin Descriptions

Table 16: SDIO Pin Description

<i>SD 4-Bit Mode</i>		<i>SD 1-Bit Mode</i>		<i>gSPI Mode</i>	
DATA0	Data line 0	DATA	Data line	DO	Data output
DATA1	Data line 1 or Interrupt	IRQ	Interrupt	IRQ	Interrupt
DATA2	Data line 2 or Read Wait	RW	Read Wait	NC	Not used
DATA3	Data line 3	N/C	Not used	CS	Card select
CLK	Clock	CLK	Clock	SCLK	Clock
CMD	Command line	CMD	Command line	DI	Data input

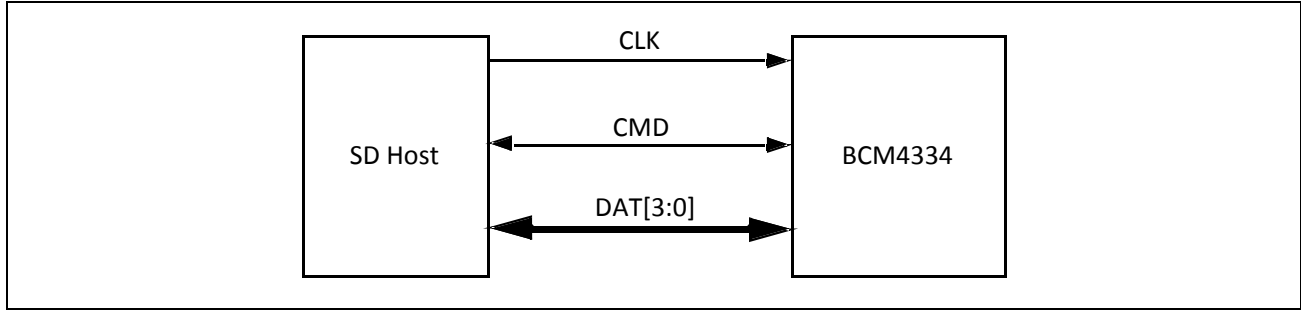

Figure 23: Signal Connections to SDIO Host (SD 4-Bit Mode)

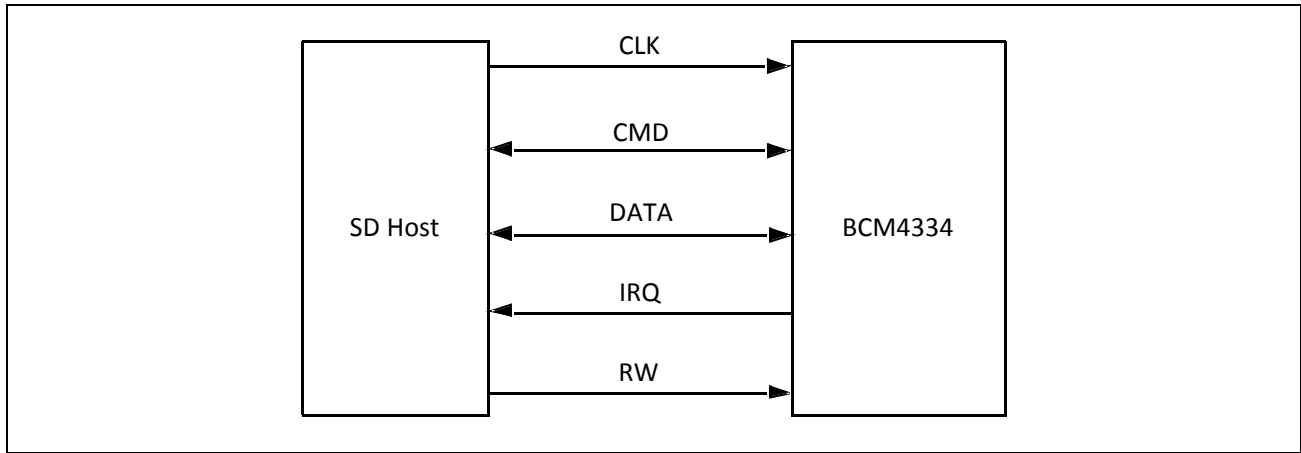

Figure 24: Signal Connections to SDIO Host (SD 1-Bit Mode)

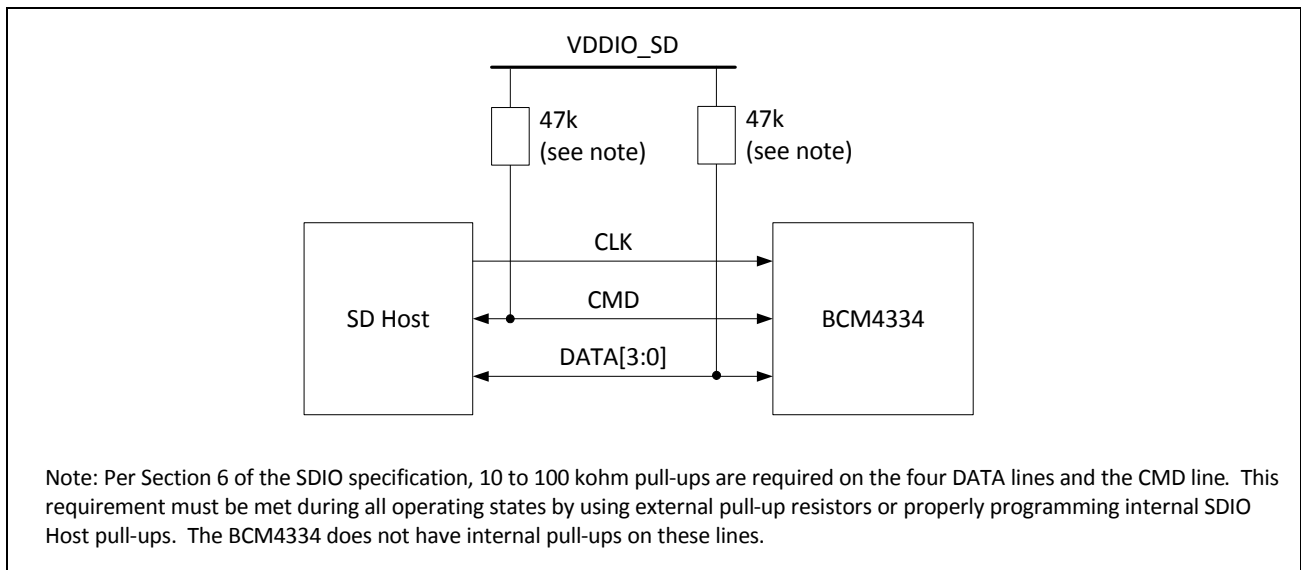

Figure 25: SDIO Pull-Up Requirements

Not Recommended for New Designs

Generic SPI Mode

In addition to the full SDIO mode, the BCM4334 includes the option of using the simplified generic SPI (gSPI) interface/protocol. Characteristics of the gSPI mode include:

- Supports up to 48 MHz operation
- Supports fixed delays for responses and data from device
- Supports alignment to host gSPI frames (16 or 32 bits)
- Supports up to 2 KB frame size per transfer
- Supports little endian (default) and big endian configurations
- Supports configurable active edge for shifting
- Supports packet transfer through DMA for WLAN

gSPI mode is enabled using the strapping option pins strap_host_ifc_[3:1], [Table 21: “WLAN GPIO Functions and Strapping Options \(Advance Information\),” on page 106.](#)

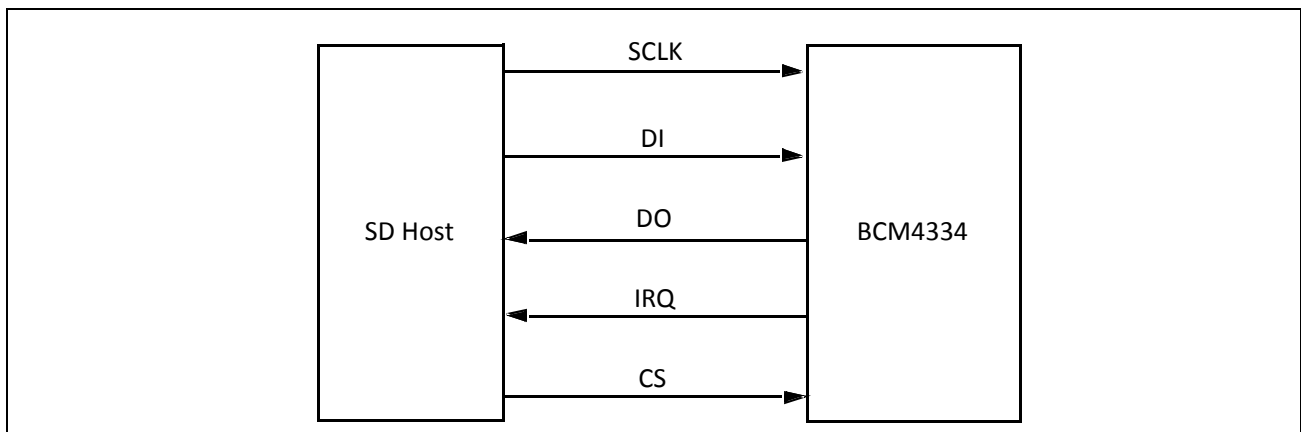

Figure 26: Signal Connections to SDIO Host (gSPI Mode)

Not Recommended for New Designs

SPI Protocol

The SPI protocol supports both 16-bit and 32-bit word operation. Byte endianness is supported in both modes. Figure 27 and Figure 28 show the basic write and write/read commands.

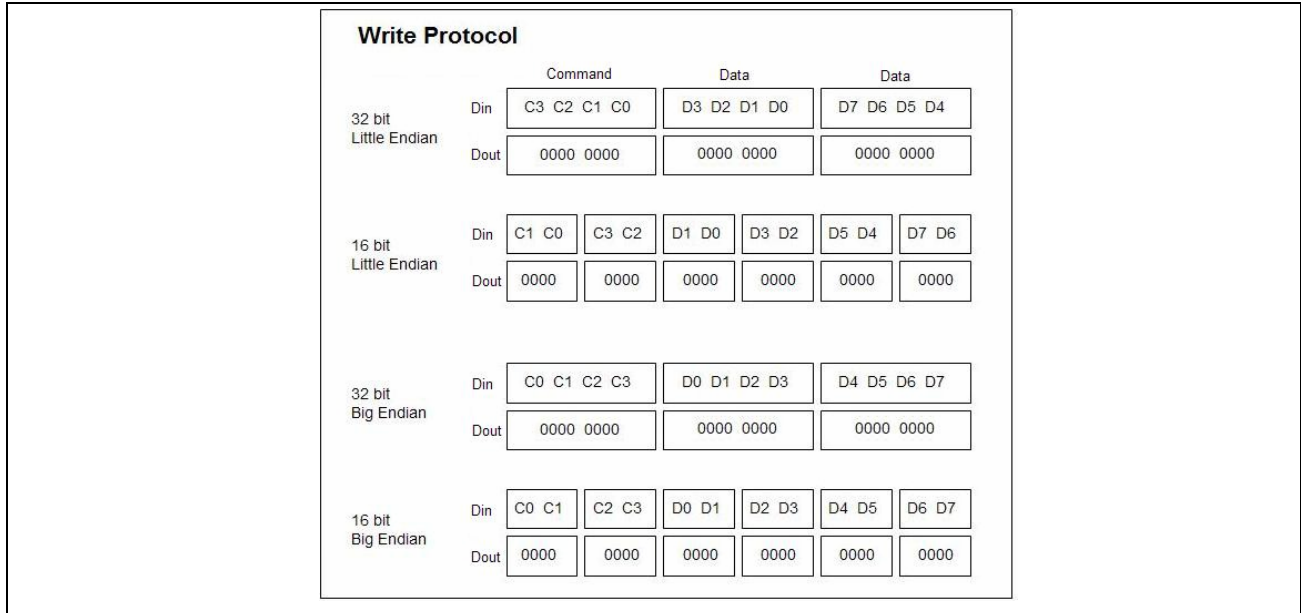

Figure 27: gSPI Write Protocol

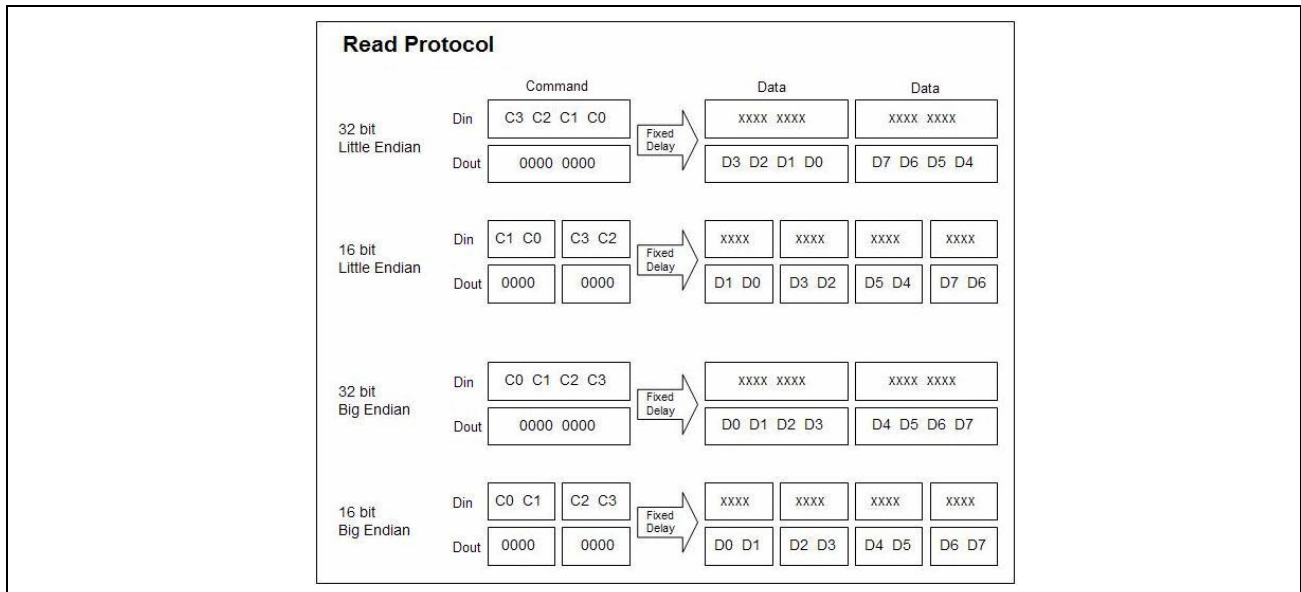

Figure 28: gSPI Read Protocol

Not Recommended for New Designs

Command Structure

The gSPI command structure is 32 bits. The bit positions and definitions are as shown in [Figure 29](#).

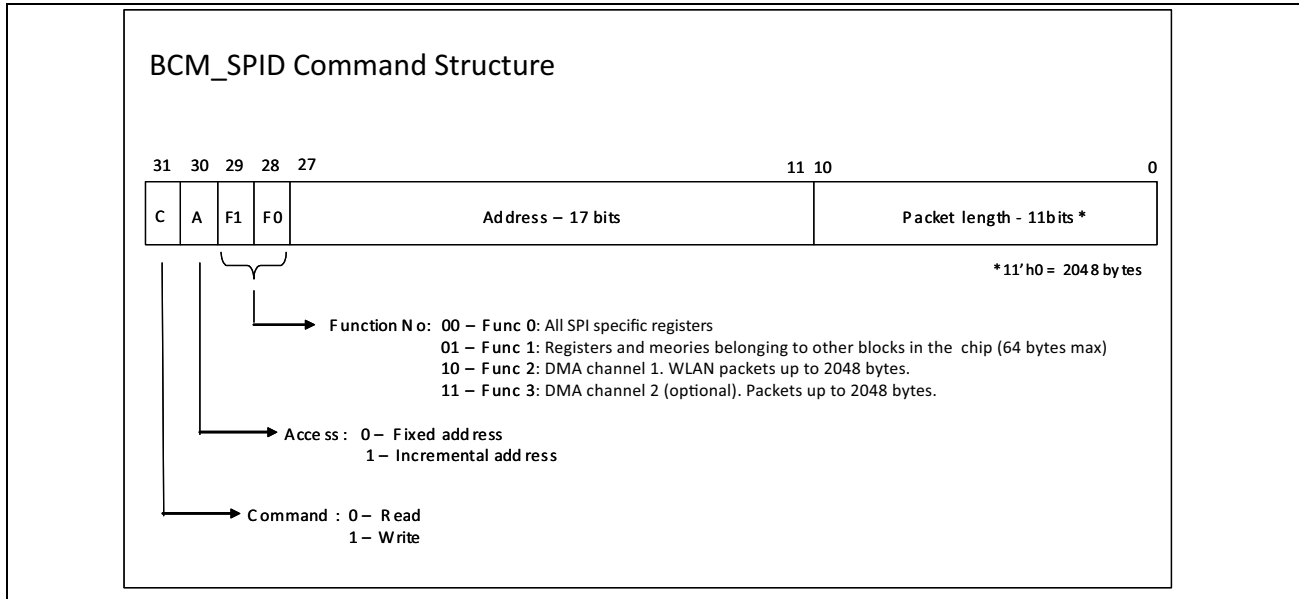

Figure 29: gSPI Command Structure

Write

The host puts the first bit of the data onto the bus half a clock-cycle before the first active edge following the CS going low. The following bits are clocked out on the falling edge of the gSPI clock. The device samples the data on the active edge.

Write/Read

The host reads on the rising edge of the clock requiring data from the device to be made available before the first rising clock edge of the clock burst for the data. The last clock edge of the fixed delay word can be used to represent the first bit of the following data word. This allows data to be ready for the first clock edge without relying on asynchronous delays.

Read

The read command always follows a separate write to set up the WLAN device for a read. This command differs from the write/read command in the following respects: a) chip selects go high between the command/address and the data and b) the time interval between the command/address is not fixed.

Not Recommended for New Designs

Status

The gSPI interface supports status notification to the host after a read/write transaction. This status notification provides information about any packet errors, protocol errors, information about available packet in the RX queue, etc. The status information helps in reducing the number of interrupts to the host. The status-reporting feature can be switched off using a register bit, without any timing overhead. The gSPI bus timing for read/write transactions with and without status notification are as shown in Figure 30 and Figure 31 on page 77. See Table 17 on page 77 for information on status field details.

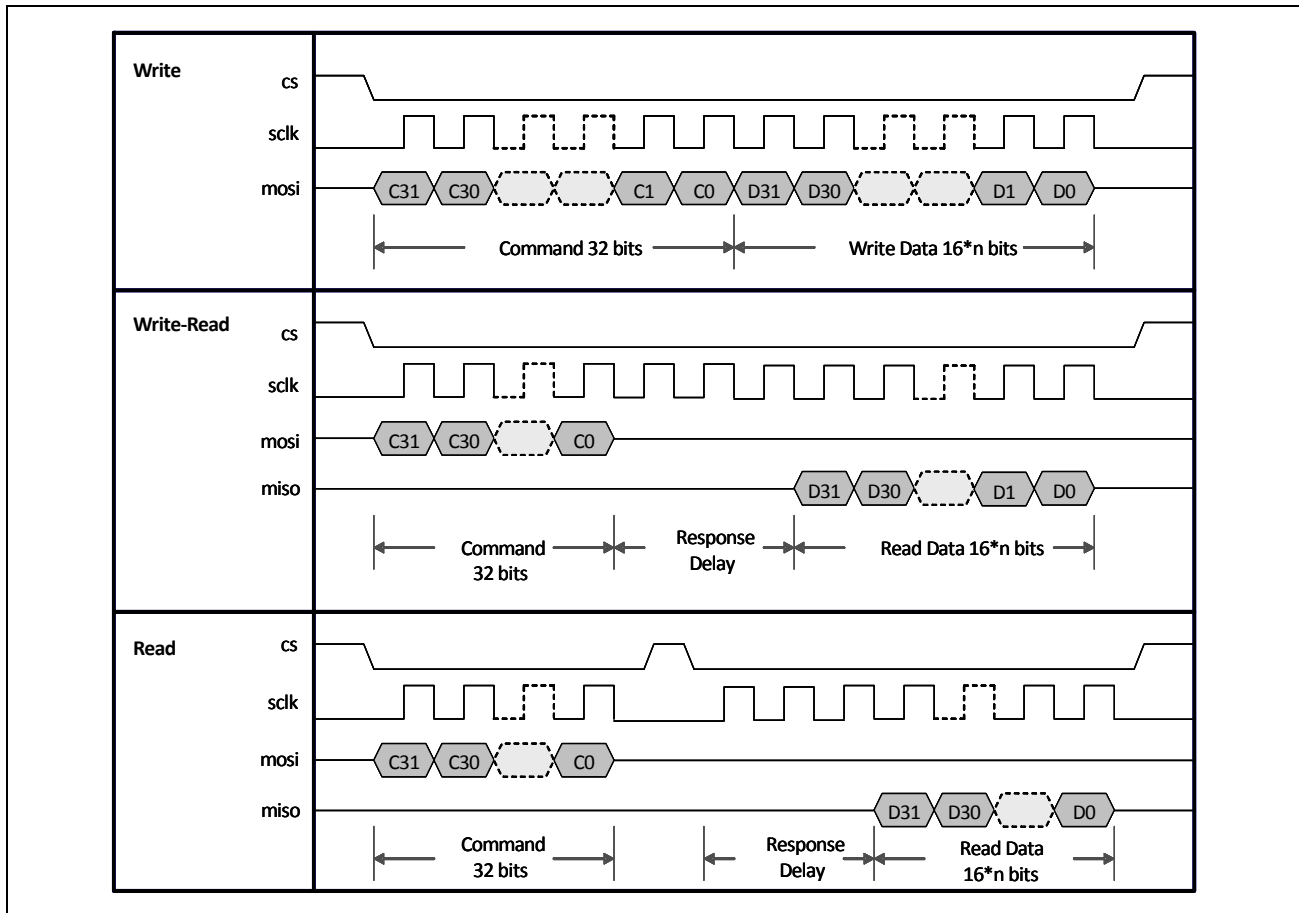

Figure 30: gSPI Signal Timing Without Status (32-bit big endian shown)

Not Recommended for New Designs

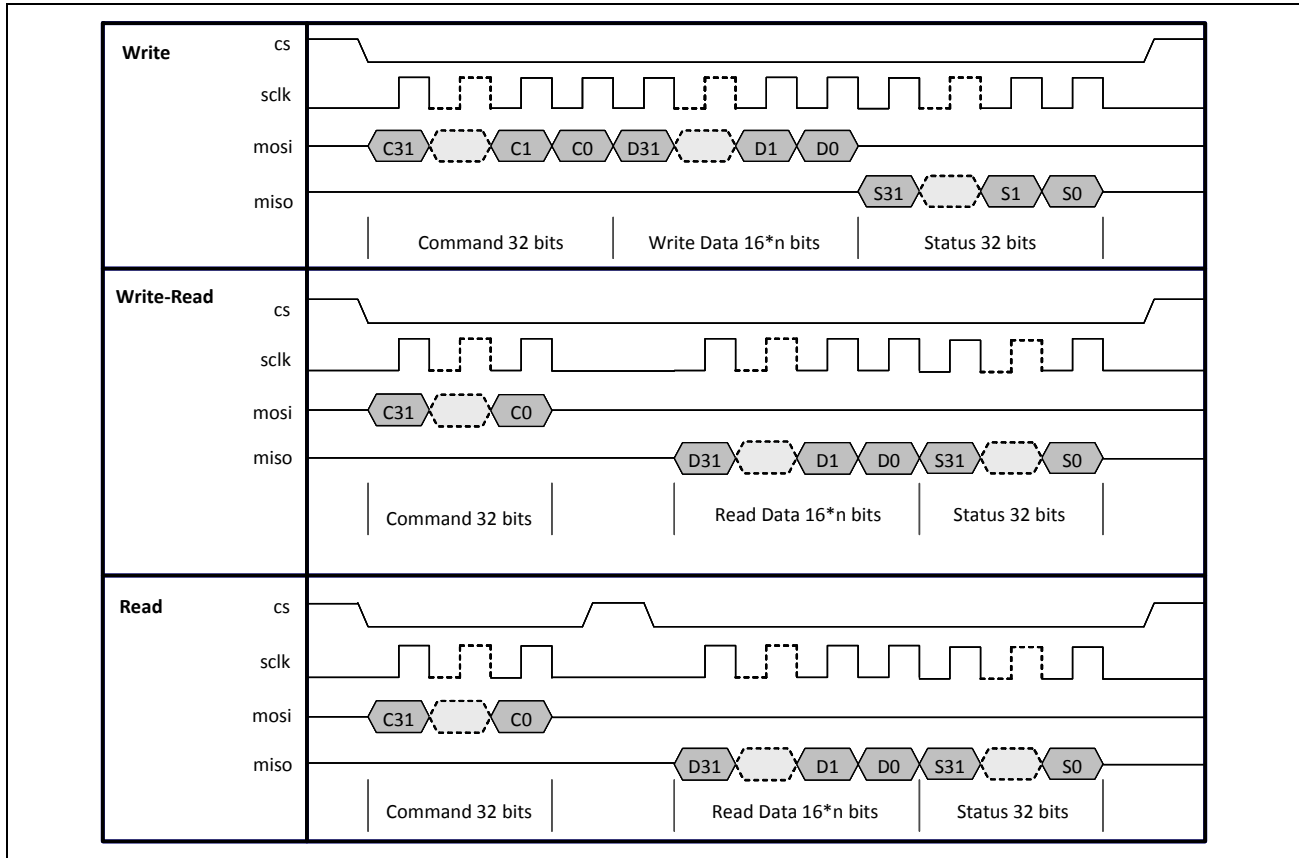

Figure 31: gSPI Signal Timing with Status (Response Delay = 0) (32-bit big endian shown)

Table 17: gSPI Status Field Details

Bit	Name	Description
0	Data not available	The requested read data is not available
1	Underflow	FIFO underflow occurred due to current (F2, F3) read command
2	Overflow	FIFO overflow occurred due to current (F1, F2, F3) write command
3	F2 interrupt	F2 channel interrupt
4	F3 interrupt	F3 channel interrupt
5	F2 RX Ready	F2 FIFO is ready to receive data (FIFO empty)
6	F3 RX Ready	F3 FIFO is ready to receive data (FIFO empty)
7	Reserved	—
8	F2 Packet Available	Packet is available/ready in F2 TX FIFO
9:19	F2 Packet Length	Length of packet available in F2 FIFO
20	F3 Packet Available	Packet is available/ready in F3 TX FIFO
21:31	F3 Packet Length	Length of packet available in F3 FIFO

gSPI Host-Device Handshake

To initiate communication through the gSPI after power-up, the host needs to bring up the WLAN/Chip by writing to the wake-up WLAN register bit. Writing a 1 to this bit will start up the necessary crystals and PLLs so that the BCM4334 is ready for data transfer. The device can signal an interrupt to the host indicating that the device is awake and ready. This procedure also needs to be followed for waking up the device in sleep mode. The device can interrupt the host using the WLAN IRQ line whenever it has any information to pass to the host. On getting an interrupt, the host needs to read the interrupt and/or status register to determine the cause of interrupt and then take necessary actions.

Boot-Up Sequence

After power-up, the gSPI host needs to wait 150 ms for the device to be out of reset. For this, the host needs to poll with a read command to F0 addr 0x14. Address 0x14 contains a predefined bit pattern. As soon as the host gets a response back with the correct register content, it implies that the device has powered up and is out of reset. After that, the host needs to set the wakeup-WLAN bit (F0 reg 0x00 bit 7). The wakeup-WLAN issues a clock request to the PMU.

For the first time after power-up, the host must wait for the availability of low power clock inside the device. Once that is available, the host must write to a PMU register to set the crystal frequency, which turns on the PLL. After the PLL is locked, the chipActive interrupt is issued to the host. This interrupt indicates the device awake/ready status. See [Table 18](#) for information on gSPI registers.

In [Table 18](#), the following notation is used for register access:

- R: Readable from host and CPU
- W: Writable from host
- U: Writable from CPU

Table 18: gSPI Registers

Address	Register	Bit	Access	Default	Description
x0000	Word length	0	R/W/U	0	0: 16 bit word length 1: 32 bit word length
	Endianness	1	R/W/U	0	0: Little Endian 1: Big Endian
	High-speed mode	4	R/W/U	1	0: Normal mode. RX and TX at different edges. 1: High speed mode. RX and TX on same edge (default).
	Interrupt polarity	5	R/W/U	1	0: Interrupt active polarity is low 1: Interrupt active polarity is high (default)
	Wake-up	7	R/W	0	A write of 1 will denote a wake-up command from the host to the device. This will be followed by an F2 Interrupt from the gSPI device to the host, indicating device awake status.
x0001	Response delay	7:0	R/W/U	8'h04	Configurable read response delay in multiples of 8 bits

Table 18: gSPI Registers (Cont.)

Address	Register	Bit	Access	Default	Description
x0002	Status enable	0	R/W	1	0: no status sent to host after read/write 1: status sent to host after read/write
	Interrupt with status	1	R/W	0	0: do not interrupt if status is sent 1: interrupt host even if status is sent
	Response delay for all	2	R/W	0	0: response delay applicable to F1 read only 1: response delay applicable to all function read
x0003	Reserved	–	–	–	–
x0004	Interrupt register	0	R/W	0	Requested data not available; Cleared by writing a 1 to this location
		1	R	0	F2/F3 FIFO underflow due to last read
		2	R	0	F2/F3 FIFO overflow due to last write
		5	R	0	F2 packet available
		6	R	0	F3 packet available
		7	R	0	F1 overflow due to last write
		x0005	Interrupt register	5	R
6	R			0	F2 Interrupt
7	R			0	F3 Interrupt
x0006– x0007	Interrupt enable register	15:0	R/W/U	16'hE0E7	Particular Interrupt is enabled if a corresponding bit is set
x0008– x000B	Status register	31:0	R	32'h0000	Same as status bit definitions
x000C– x000D	F1 info register	0	R	1	F1 enabled
		1	R	0	F1 ready for data transfer
		13:2	R/U	12'h40	F1 max packet size
x000E– x000F	F2 info register	0	R/U	1	F2 enabled
		1	R	0	F2 ready for data transfer
		15:2	R/U	14'h800	F2 max packet size
x0010– x0011	F3 info register	0	R/U	1	F3 enabled
		1	R	0	F3 ready for data transfer
		15:2	R/U	14'h800	F3 max packet size
x0014– x0017	Test–Read only register	31:0	R	32'hFEED BEAD	This register contains a predefined pattern, which the host can read and determine if the gSPI interface is working properly.
x0018– x001B	Test–R/W register	31:0	R/W/U	32'h0000 0000	This is a dummy register where the host can write some pattern and read it back to determine if the gSPI interface is working properly.

Not Recommended for New Designs

Figure 32 shows the WLAN boot-up sequence from power-up to firmware download.

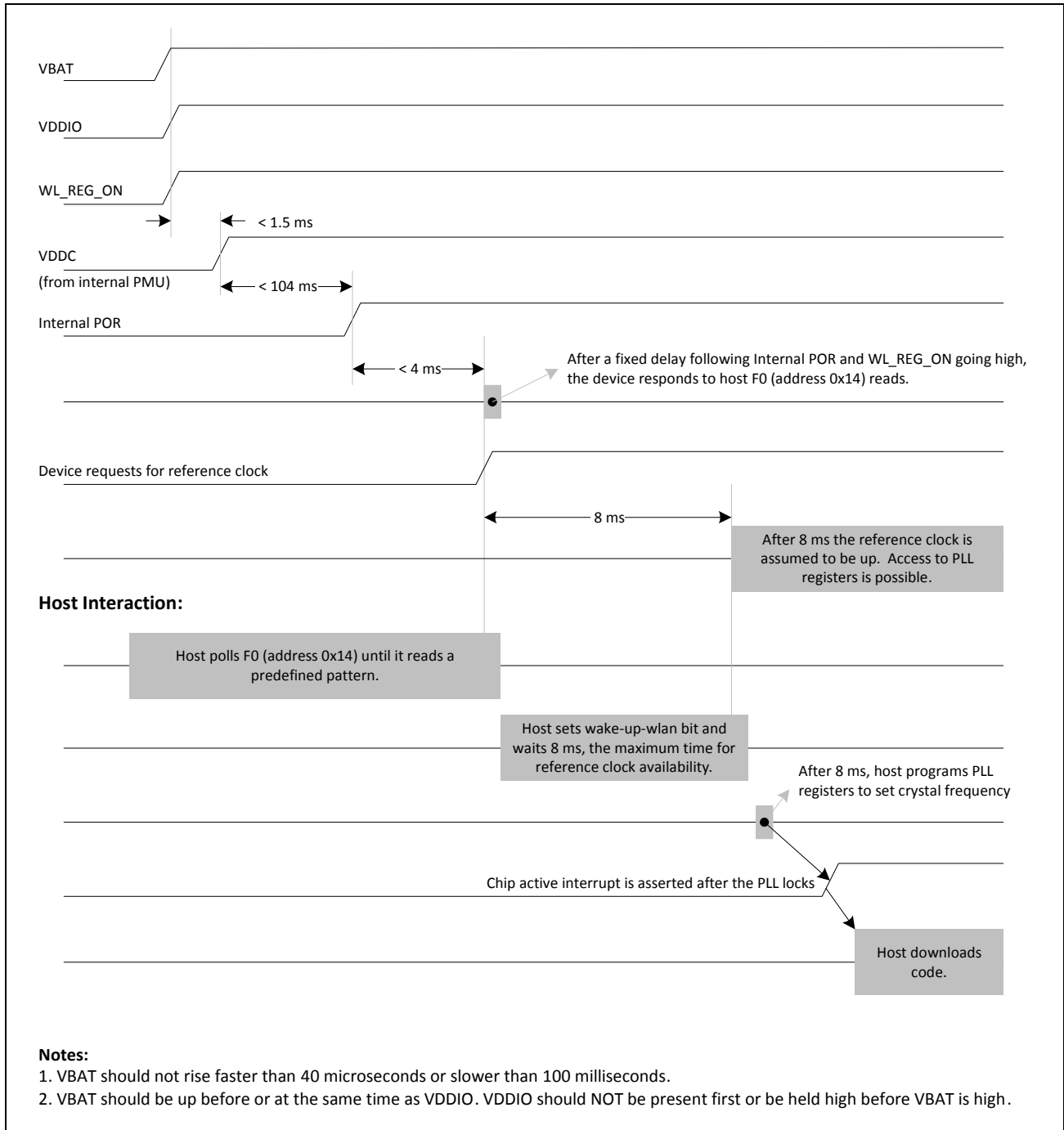

Figure 32: WLAN Boot-Up Sequence

Not Recommended for New Designs

HSIC Interface

As an alternative to SDIO, an HSIC host interface can be enabled using the strapping option pins strap_host_ifc_[3:1] (Table 21: “WLAN GPIO Functions and Strapping Options (Advance Information),” on page 106. HSIC is a simplified derivative of the USB2.0 interface designed to replace a standard USB PHY and cable for short distances (up to 10 cm) on board point-to-point connections. Using two signals, a bidirectional data strobe (STROBE) and a bidirectional DDR data signal (DATA), it provides high-speed serial 480 Mbps data transfers that are 100% host driver compatible with traditional USB 2.0 cable-connected topologies.

Figure 33 shows the blocks in the HSIC device core.

Key features of HSIC include:

- High-speed 480 Mbps data rate
- Source-synchronous serial interface using 1.2V LVCMOS signal levels
- No power consumed except when a data transfer is in progress
- Maximum trace length of 10 cm.
- No Plug-n-Play support, no hot attach/removal

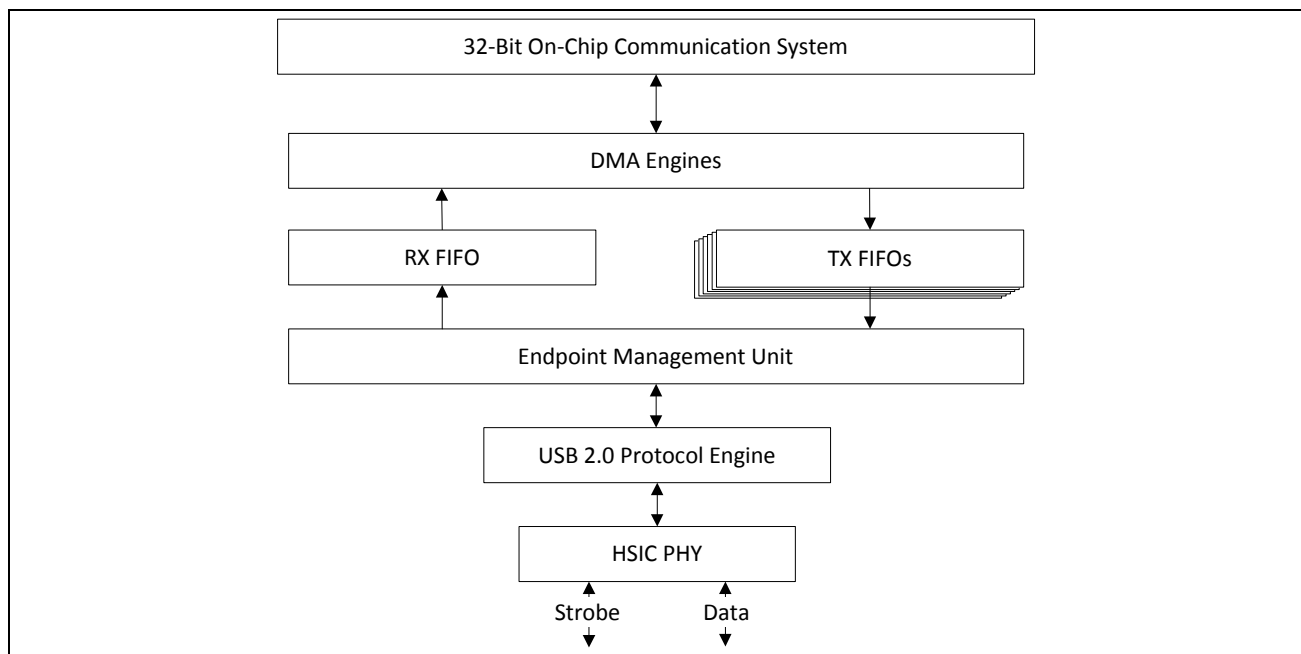

Figure 33: HSIC Device Block Diagram

Not Recommended for New Designs

Section 12: Wireless LAN MAC and PHY

MAC Features

The BCM4334 WLAN media access controller (MAC) supports features specified in the IEEE 802.11 base standard, and amended by IEEE 802.11n. The salient features are listed below:

- Transmission and reception of aggregated MPDUs (A-MPDU)
- Support for power management schemes, including WMM power-save, power-save multi-poll (PSMP) and multiphase PSMP operation
- Support for immediate ACK and Block-ACK policies
- Interframe space timing support, including RIFS
- Support for RTS/CTS and CTS-to-self frame sequences for protecting frame exchanges
- Back-off counters in hardware for supporting multiple priorities as specified in the WMM specification
- Timing synchronization function (TSF), network allocation vector (NAV) maintenance, and target beacon transmission time (TBTT) generation in hardware
- Hardware offload for AES-CCMP, legacy WPA TKIP, legacy WEP ciphers, and support for key management
- Support for coexistence with Bluetooth and other external radios
- Programmable independent basic service set (IBSS) or infrastructure basic service set functionality
- Statistics counters for MIB support

MAC Description

The BCM4334 WLAN MAC is designed to support high-throughput operation with low-power consumption. It does so without compromising the Bluetooth coexistence policies, thereby enabling optimal performance over both networks. In addition, several power saving modes have been implemented that allow the MAC to consume very little power while maintaining network-wide timing synchronization. The architecture diagram of the MAC is shown in [Figure 34 on page 83](#).

The following sections provide an overview of the important modules in the MAC.

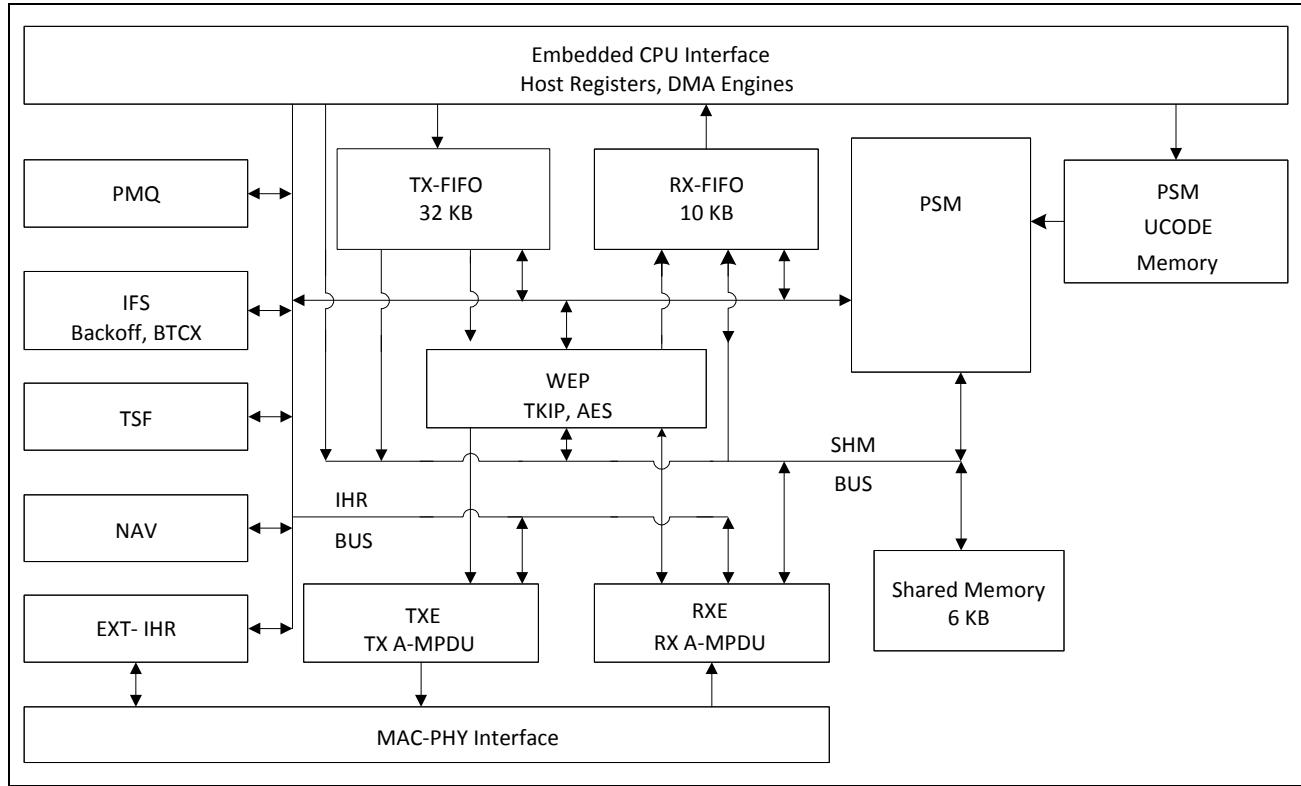

Figure 34: WLAN MAC Architecture

PSM

The programmable state machine (PSM) is a micro-coded engine, which provides most of the low-level control to the hardware, to implement the IEEE 802.11 specification. It is a microcontroller that is highly optimized for flow control operations, which are predominant in implementations of communication protocols. The instruction set and fundamental operations are simple and general, which allows algorithms to be optimized until very late in the design process. It also allows for changes to the algorithms to track evolving IEEE 802.11 specifications.

The PSM fetches instructions from the microcode memory. It uses the shared memory to obtain operands for instructions, as a data store, and to exchange data between both the host and the MAC data pipeline (via the SHM bus). The PSM also uses a scratchpad memory (similar to a register bank) to store frequently accessed and temporary variables.

The PSM exercises fine-grained control over the hardware engines, by programming internal hardware registers (IHR). These IHRs are co-located with the hardware functions they control, and are accessed by the PSM via the IHR bus.

The PSM fetches instructions from the microcode memory using an address determined by the program counter, instruction literal, or a program stack. For ALU operations the operands are obtained from shared memory, scratchpad, IHRs, or instruction literals, and the results are written into the shared memory, scratchpad, or IHRs.

There are two basic branch instructions: conditional branches and ALU based branches. To better support the many decision points in the IEEE 802.11 algorithms, branches can depend on either a readily available signals from the hardware modules (branch condition signals are available to the PSM without polling the IHRs), or on the results of ALU operations.

WEP

The wired equivalent privacy (WEP) engine encapsulates all the hardware accelerators to perform the encryption and decryption, and MIC computation and verification. The accelerators implement the following cipher algorithms: legacy WEP, WPA TKIP, WPA2 AES-CCMP.

The PSM determines, based on the frame type and association information, the appropriate cipher algorithm to be used. It supplies the keys to the hardware engines from an on-chip key table. The WEP interfaces with the TXE to encrypt and compute the MIC on transmit frames, and the RXE to decrypt and verify the MIC on receive frames.

TXE

The transmit engine (TXE) constitutes the transmit data path of the MAC. It coordinates the DMA engines to store the transmit frames in the TXFIFO. It interfaces with WEP module to encrypt frames, and transfers the frames across the MAC-PHY interface at the appropriate time determined by the channel access mechanisms.

The data received from the DMA engines are stored in transmit FIFOs. The MAC supports multiple logical queues to support traffic streams that have different QoS priority requirements. The PSM uses the channel access information from the IFS module to schedule a queue from which the next frame is transmitted. Once the frame is scheduled, the TXE hardware transmits the frame based on a precise timing trigger received from the IFS module.

The TXE module also contains the hardware that allows the rapid assembly of MPDUs into an A-MPDU for transmission. The hardware module aggregates the encrypted MPDUs by adding appropriate headers and pad delimiters as needed.

RXE

The receive engine (RXE) constitutes the receive data path of the MAC. It interfaces with the DMA engine to drain the received frames from the RXFIFO. It transfers bytes across the MAC-PHY interface and interfaces with the WEP module to decrypt frames. The decrypted data is stored in the RXFIFO.

The RXE module contains programmable filters that are programmed by the PSM to accept or filter frames based on several criteria such as receiver address, BSSID, and certain frame types.

The RXE module also contains the hardware required to detect A-MPDUs, parse the headers of the containers, and disaggregate them into component MPDUS.

IFS

The IFS module contains the timers required to determine interframe space timing including RIFS timing. It also contains multiple backoff engines required to support prioritized access to the medium as specified by WMM.

The interframe spacing timers are triggered by the cessation of channel activity on the medium, as indicated by the PHY. These timers provide precise timing to the TXE to begin frame transmission. The TXE uses this information to send response frames or perform transmit frame-bursting (RIFS or SIFS separated, as within a TXOP).

The backoff engines (for each access category) monitor channel activity, in each slot duration, to determine whether to continue or pause the backoff counters. When the backoff counters reach 0, the TXE gets notified, so that it may commence frame transmission. In the event of multiple backoff counters decrementing to 0 at the same time, the hardware resolves the conflict based on policies provided by the PSM.

The IFS module also incorporates hardware that allows the MAC to enter a low-power state when operating under the IEEE power save mode. In this mode, the MAC is in a suspended state with its clock turned off. A sleep timer, whose count value is initialized by the PSM, runs on a slow clock and determines the duration over which the MAC remains in this suspended state. Once the timer expires the MAC is restored to its functional state. The PSM updates the TSF timer based on the sleep duration ensuring that the TSF is synchronized to the network.

The IFS module also contains the PTA hardware that assists the PSM in Bluetooth coexistence functions.

TSF

The timing synchronization function (TSF) module maintains the TSF timer of the MAC. It also maintains the target beacon transmission time (TBTT). The TSF timer hardware, under the control of the PSM, is capable of adopting timestamps received from beacon and probe response frames in order to maintain synchronization with the network.

The TSF module also generates trigger signals for events that are specified as offsets from the TSF timer, such as uplink and downlink transmission times used in PSMP.

NAV

The network allocation vector (NAV) timer module is responsible for maintaining the NAV information conveyed through the duration field of MAC frames. This ensures that the MAC complies with the protection mechanisms specified in the standard.

The hardware, under the control of the PSM, maintains the NAV timer and updates the timer appropriately based on received frames. This timing information is provided to the IFS module, which uses it as a virtual carrier-sense indication.

MAC-PHY Interface

The MAC-PHY interface consists of a data path interface to exchange RX/TX data from/to the PHY. In addition, there is an programming interface, which can be controlled either by the host or the PSM to configure and control the PHY.

WLAN PHY Description

The BCM4334 WLAN Digital PHY is designed to comply with IEEE 802.11a/b/g/n single-stream to provide wireless LAN connectivity supporting data rates from 1 Mbps to 150 Mbps for low-power, high-performance handheld applications.

The PHY has been designed to work with interference, radio nonlinearity, and impairments. It incorporates efficient implementations of the filters, FFT and Viterbi decoder algorithms. Efficient algorithms have been designed to achieve maximum throughput and reliability, including algorithms for carrier sense/rejection, frequency/phase/timing acquisition and tracking, channel estimation and tracking. The PHY receiver also contains a robust IEEE 802.11b demodulator. The PHY carrier sense has been tuned to provide high throughput for IEEE 802.11g/11b hybrid networks with Bluetooth coexistence. It has also been designed for shared single antenna systems between WL and BT to support simultaneous Rx-Rx.

PHY Features

- Supports IEEE 802.11a, 11b, 11g, and 11n single-stream PHY standards.
- IEEE 802.11n single-stream operation in 20 MHz and 40 MHz channels
- Supports Optional Short GI and Green Field modes in Tx and Rx.
- Supports optional space-time block code (STBC) receive of two space-time streams.
- Tx LDPC for improved range and power efficiency
- Supports IEEE 802.11h/k for worldwide operation.
- Advanced algorithms for low power, enhanced sensitivity, range, and reliability
- Algorithms to improve performance in presence of Bluetooth
- Simultaneous Rx-Rx (WL-BT) architecture
- Automatic gain control scheme for blocking and non blocking application scenario for cellular applications
- Closed loop transmit power control
- Digital RF chip calibration algorithms to handle CMOS RF chip non-idealities
- On-the-fly channel frequency and transmit power selection
- Supports per packet Rx antenna diversity.
- Designed to meet FCC and other worldwide regulatory requirements.

Not Recommended for New Designs

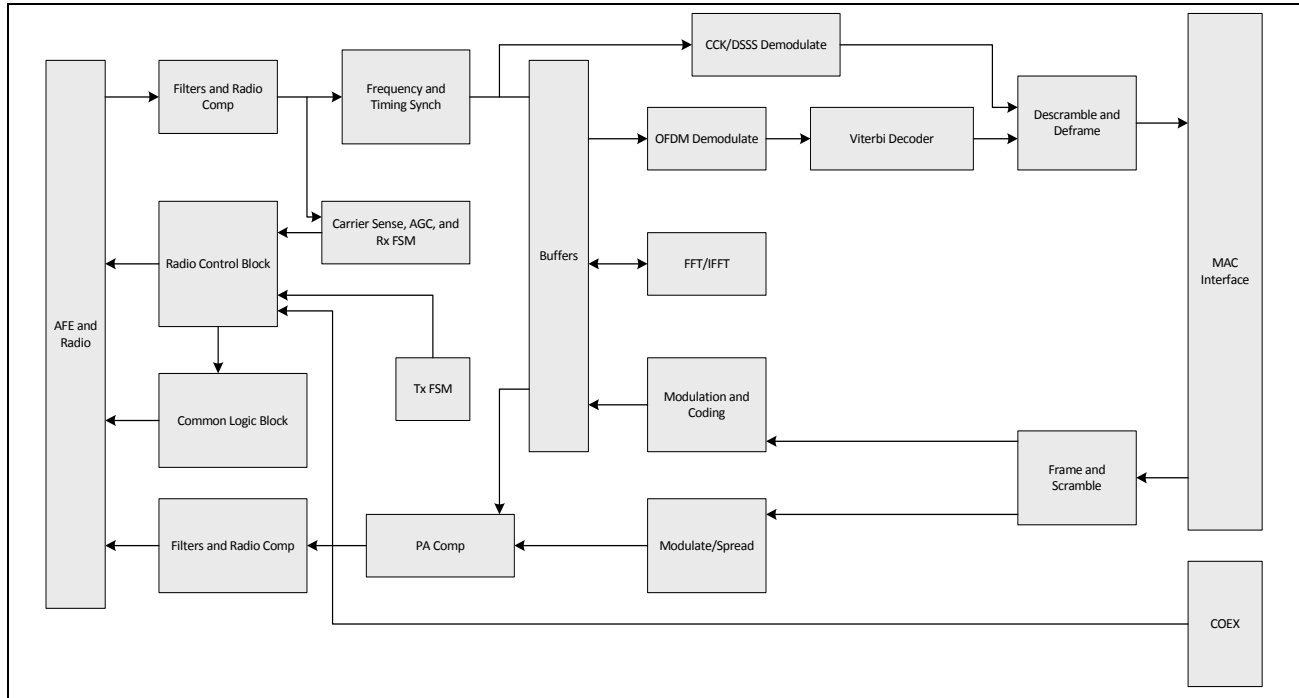

Figure 35: WLAN PHY Block Diagram

One of the key features of the PHY is its space-time block coding (STBC) capability. The STBC scheme can obtain diversity gains in a fading channel environment. On a connection with an access point that uses multiple transmit antennas and supports STBC, the BCM4334 can process two space-time streams to improve receiver performance. Figure 36 on page 87 is a block diagram showing the STBC implementation in the receive path.

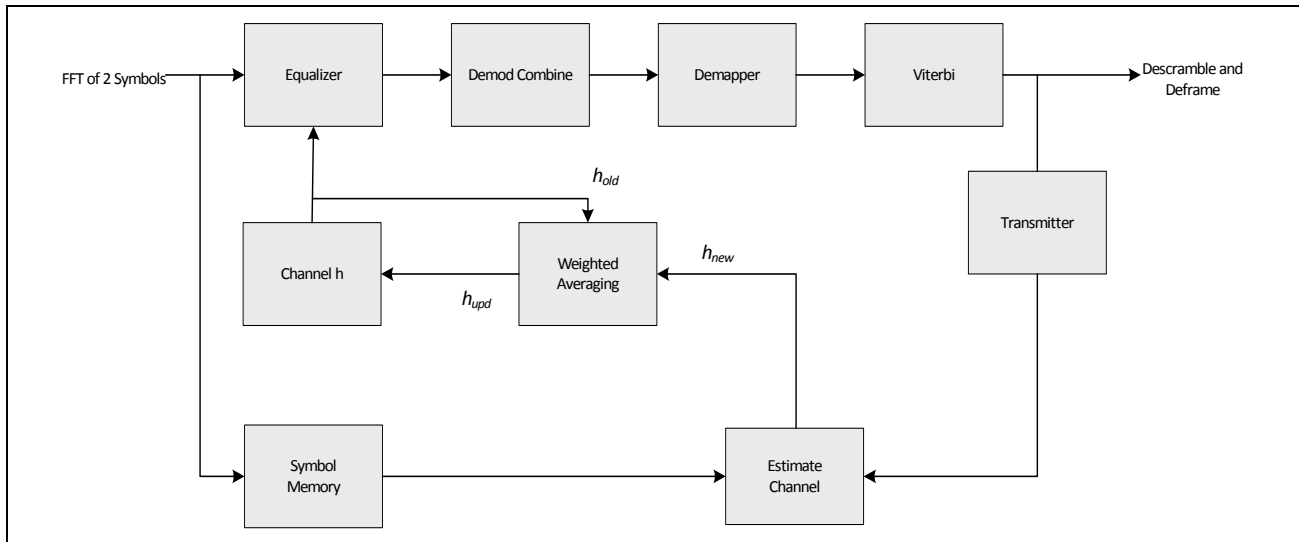

Figure 36: STBC Implementation in the Receive Path

In STBC mode, symbols are processed in pairs. Equalized output symbols are linearly combined and decoded. The channel estimate is refined on every pair of symbols using the received symbols and reconstructed symbols.

Not Recommended for New Designs

Section 13: WLAN Radio Subsystem

The BCM4334 includes an integrated dual-band WLAN RF transceiver that has been optimized for use in 2.4 GHz and 5 GHz Wireless LAN systems. It has been designed to provide low-power, low-cost, and robust communications for applications operating in the globally available 2.4 GHz unlicensed ISM or 5 GHz U-NII bands. The transmit and receive sections include all on-chip filtering, mixing, and gain control functions.

Up to 11 (WLCSP = 11, WLPGA = 8) RF control signals are available to drive the external RF switches and support external power amplifiers and low noise amplifiers for each band. See the reference board schematics for further details.

Receiver Path

The BCM4334 has a wide dynamic range, direct conversion receiver. It employs high order on-chip channel filtering to ensure reliable operation in the noisy 2.4 GHz ISM band or the entire 5 GHz U-NII band. Control signals are available that can support the use of optional external low noise amplifiers (LNA), which can increase the receive sensitivity by several dB.

Transmit Path

Baseband data is modulated and upconverted to the 2.4 GHz ISM or 5-GHz U-NII bands, respectively. Linear on-chip PA drivers are included, which are designed to drive external power amplifiers.

These PA drivers can be powered directly from VBAT; thus, if the external PAs are also capable of being powered directly from VBAT, the need for a PALDO is eliminated. Closed-loop output power control is provided by means of a-band and g-band TSSI inputs from external power detectors.

Several spare RF control signals are available to support the external power amplifiers and RF switches for either or both bands.

Calibration

The BCM4334 features dynamic and automatic on-chip calibration to continually compensate for temperature and process variations across components. This enables the BCM4334 to be used in high-volume applications, because calibration routines are not required during manufacturing testing. These calibration routines are performed periodically in the course of normal radio operation. Examples of some of the automatic calibration algorithms are baseband filter calibration for optimum transmit and receive performance and LOFT calibration for carrier leakage reduction. In addition, I/Q Calibration, R Calibration, and VCO Calibration are performed on-chip. No per-board calibration is required in manufacturing test, which helps to minimize test time and cost during large volume production.

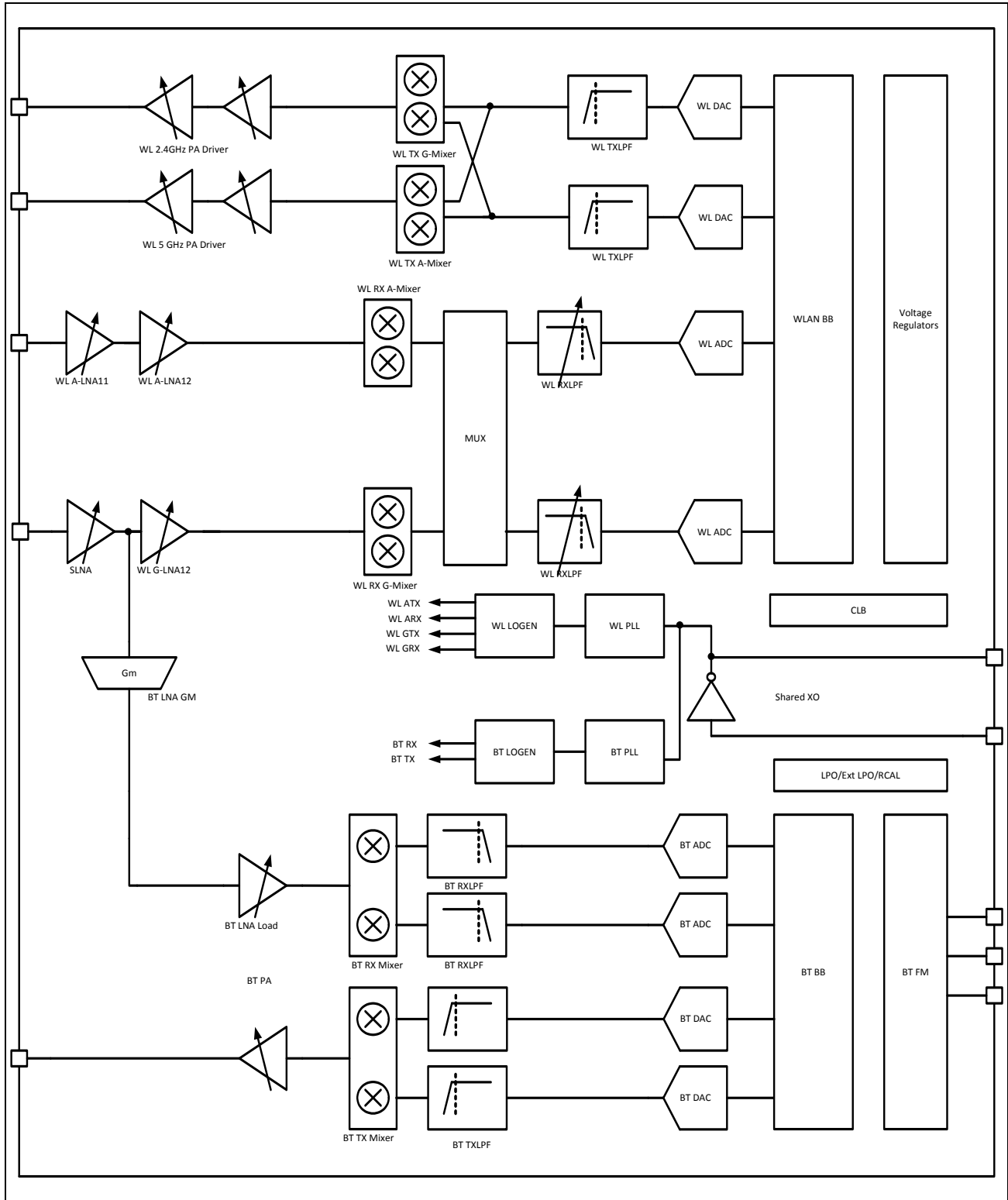

Figure 37: Radio Functional Block Diagram

Not Recommended for New Designs

Section 14: Pinout and Signal Descriptions

Signal Assignments

Figure 38 shows the WLBGA ball map. Figure 39 shows the WLCSP bump map.

Table 19 on page 92 contains the WLCSP bump coordinates.

Table 20 on page 98 contains the signal description for all packages.

	10	9	8	7	6	5	4	3	2	1	
A	SR_PVSS	SR_VDDBATP5V	LDO_VDD1P5	VOUT_LNLDO	CLK_REQ	BT_REG_ON	WL_REG_ON	FM_PLLVDD	FM_VCOVSS	FM_LNAVCOVDD	A
B	SR_VLX	SR_VDDBATA5V	VOUT_CLDO	VOUT_3P3	LPO_IN	BT_UART_RXD	BT_DEV_WAKE/GPIO0	FM_PLLVSS	FM_LNAVSS	FM_RFIN	B
C	PMU_AVSS	VSSC	VDDIO	BT_PCM_CLK	VDDC	VSSC	BT_PCM_SYNC	BT_PLLVSS	BT_VCOVSS	BT_VCOVDD	C
D	HSIC_STROBE	AGND12PLL	HSIC_DVDD1p2_O UT	BT_PCM_IN	VDDC	VSSC	BT_UART_CTS_N	BT_IFVDD	BT_PLLVDD	BT_LNAVDD	D
E	HSIC_DATA	RREFHSIC	SDIO_DATA_3	BT_PCM_OUT	BT_I2S_DI	BT_UART_TXD	BT_UART_RTS_N	BT_IFVSS	BT_PAVSS	BT_RF	E
F	SDIO_CLK	SDIO_DATA_1	VSSC	VDDC	BT_I2S_CLK	BT_I2S_DO	BT_HOST_WAKE/GPIO1	BT_LDOVSS	BT_VDDBAT	BT_LDOPAVDD2P5	F
G	SDIO_CMD	SDIO_DATA_0	SDIO_DATA_2	VDDIO	GPIO_3/TMS	BT_I2S_WS	WRF_AFE_GND1P2	WRF_RX_GND1P2	WRF_LNA_2G_GND 1P2	WRF_RFIN_2G	G
H	RF_SW_CTRL_4	RF_SW_CTRL_3	RF_SW_CTRL_5	GPIO_4/TDI/UART_ RX	GPIO_2/TCK	No Connect	WRF_BUCK_VDD1P5	WRF_TX_GND1P2	WRF_GPIO_OUT	WRF_RFOUT_2G	H
J	RF_SW_CTRL_0	RF_SW_CTRL_2	RF_SW_CTRL_6	GPIO_12/ JTAG_TRST_L	GPIO_6/SPI_MOD E_SEL	GPIO_1/WL_DE V_WAKE	GPIO_0/WL_HOST_WA KE	PA_Lin_Ctrl	WRF_PADRV_VBAT _GND5P0	WRF_PADRV_VBAT_V DD5P0	J
K	VDDIO_RF	RF_SW_CTRL_1	VSSC	WRF_TCXO_VDD1P8	WRF_XTAL_CAB_VD D1P2	WRF_SYNTH_VDD 1P2	WRF_SYNTH_GND1P2		WRF_G_TSSI_IN	WRF_RFOUT_5G	K
L	VDDC	GPIO_5/TDO/ UART_TX	JTAG_SEL	WRF_TCXO_CKIN2V	WRF_XTAL_CAB_ON	WRF_XTAL_CAB_OP	WRF_XTAL_CAB_GND1P2	WRF_VCO_GND1P 2	WRF_LNA_5G_GND 1P2	WRF_RFIN_5G	L
	10	9	8	7	6	5	4	3	2	1	

Figure 38: 109-WLBGA Ball Map (Bottom View)

Not Recommended for New Designs

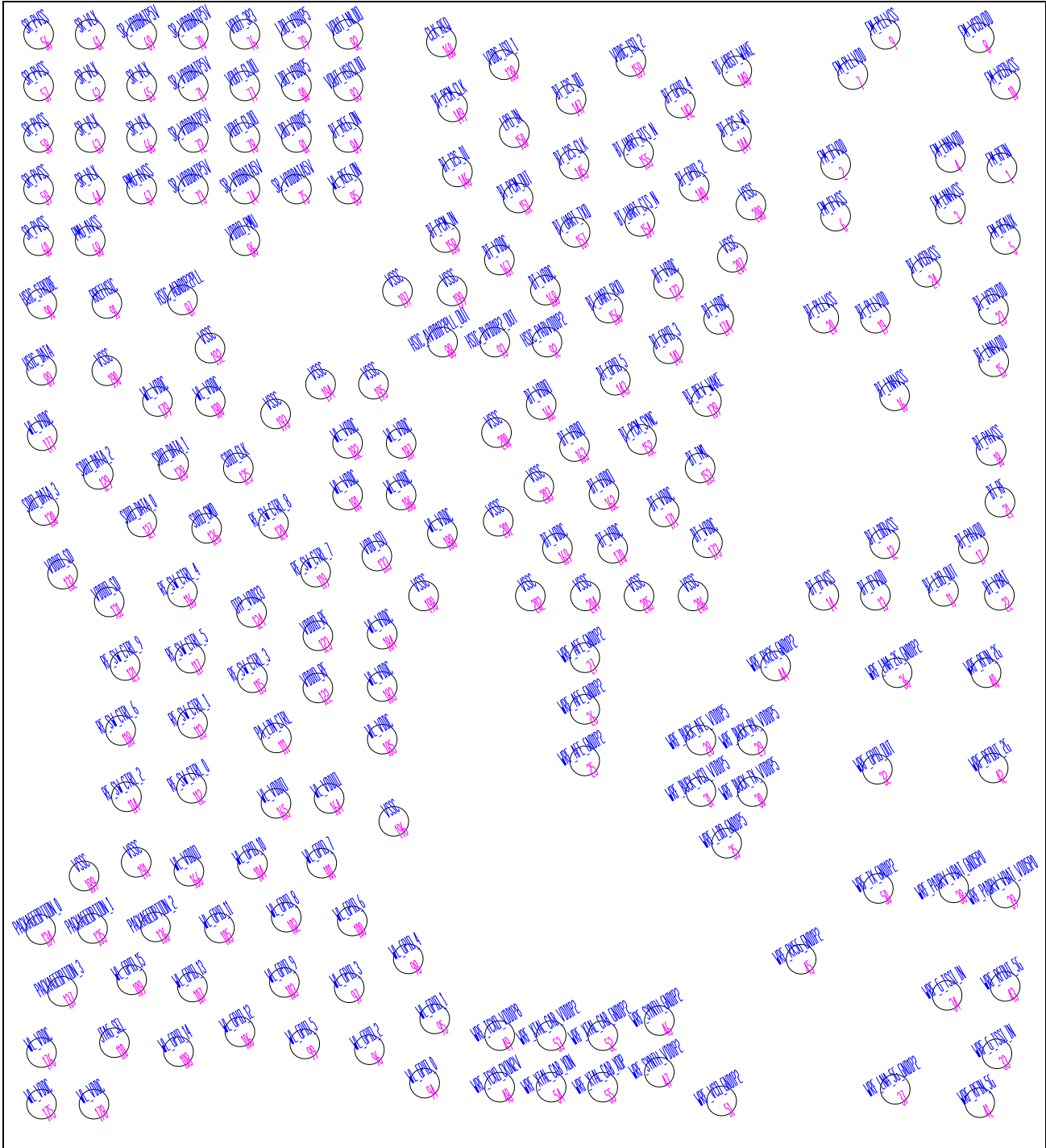

Figure 39: 208-WLCSP Bump Map (Bottom View)



Caution! This WLCSP bump map information applies only to the B series of the BCM4334. For information on the A0/A1 version, refer to the previous version of this data sheet.

Not Recommended for New Designs

Table 19: WLCSP 208–Bump Coordinates

Bump#	Signal Name	Bump Side View (0,0 center of die)		Package Top Side View (0,0 center of die)	
		X	Y	X	Y
1	FM_RFIN	1861.513	1556.690	-1861.513	1556.690
2	FM_IFVDD	1216.447	1569.799	-1216.447	1569.799
3	FM_LNAVSS	1661.515	1397.597	-1661.515	1397.597
4	FM_LNAVDD	1661.515	1597.595	-1661.515	1597.595
5	FM_RFAUX	1874.896	1279.868	-1874.896	1279.868
6	FM_IFVSS	1216.447	1369.801	-1216.447	1369.801
7	FM_PLLVDD	1283.146	1918.864	-1283.146	1918.864
8	FM_VCOVDD	1773.021	2061.473	-1773.021	2061.473
9	FM_PLLVSS	1409.718	2074.856	-1409.718	2074.856
10	FM_VCOVSS	1874.896	1880.785	-1874.896	1880.785
11	BT_LDO_OUT	1634.866	-84.600	-1634.866	-84.600
12	BT_PALDO_VSS	1406.896	99.977	-1406.896	99.977
13	BT_IFVDD	1370.410	-100.021	-1370.410	-100.021
14	BT_IFVSS	1170.412	-100.021	-1170.412	-100.021
15	BT_LNAVDD	1829.676	805.285	-1829.676	805.285
16	BT_LNAVSS	1445.092	673.187	-1445.092	673.187
17	BT_PAVDD	1750.971	81.864	-1750.971	81.864
18	BT_PAVSS	1819.443	461.507	-1819.443	461.507
19	BT_PLLVDD	1370.410	974.458	-1370.410	974.458
20	BT_PLLVSS	1170.412	974.458	-1170.412	974.458
21	BT_RF	1853.890	261.509	-1853.890	261.509
22	BT_VBAT	1851.654	-100.021	-1851.654	-100.021
23	BT_VCOVDD	1828.501	1008.356	-1828.501	1008.356
24	BT_VCOVSS	1569.112	1152.599	-1569.112	1152.599
25	WRF_AFE_GND1P2	243.196	-742.036	-243.196	-742.036
26	WRF_AFE_GND1P2	243.196	-542.038	-243.196	-542.038
27	WRF_AFE_GND1P2	243.196	-342.040	-243.196	-342.040
28	WRF_BUCK_AFE_VDD1P5	693.565	-660.924	-693.565	-660.924
29	WRF_BUCK_RX_VDD1P5	893.563	-660.924	-893.563	-660.924
30	WRF_BUCK_TX_VDD1P5	893.563	-860.922	-893.563	-860.922
31	WRF_BUCK_VCO_VDD1P5	693.565	-860.922	-693.565	-860.922
32	WRF_GPIO_OUT	1378.222	-774.355	-1378.222	-774.355
33	WRF_G_TSSI_IN	1842.033	-1877.481	-1842.033	-1877.481
34	WRF_G_TSSI_IN	1648.830	-1650.915	-1648.830	-1650.915

Not Recommended for New Designs

Table 19: WLCSP 208–Bump Coordinates (Cont.)

Bump#	Signal Name	Bump Side View (0,0 center of die)		Package Top Side View (0,0 center of die)	
		X	Y	X	Y
35	WRF_LDO_GND1P5	793.564	-1060.920	-793.564	-1060.920
36	WRF_LNA_2G_GND1P2	1454.916	-400.018	-1454.916	-400.018
37	WRF_LNA_5G_GND1P2	1447.441	-2014.947	-1447.441	-2014.947
38	WRF_PADRV_VBAT_GND5P0	1673.998	-1234.102	-1673.998	-1234.102
39	WRF_PADRV_VBAT_VDD5P0	1873.996	-1253.731	-1873.996	-1253.731
40	WRF_RFIN_2G	1799.998	-400.018	-1799.998	-400.018
41	WRF_RFIN_5G	1775.266	-2066.746	-1775.266	-2066.746
42	WRF_RFOUT_2G	1827.547	-769.585	-1827.547	-769.585
43	WRF_RFOUT_5G	1873.996	-1616.116	-1873.996	-1616.116
44	WRF_RX2G_GND1P2	983.604	-373.869	-983.604	-373.869
45	WRF_RX5G_GND1P2	1082.388	-1510.618	-1082.388	-1510.618
46	WRF_SYNTH_GND1P2	532.600	-1748.596	-532.600	-1748.596
47	WRF_SYNTH_VDD1P2	532.600	-1948.594	-532.600	-1948.594
48	WRF_TCXO_CKIN2V	-86.744	-2006.775	86.744	-2006.775
49	WRF_TCXO_VDD1P8	-86.744	-1806.777	86.744	-1806.777
50	WRF_TX_GND1P2	1381.939	-1236.406	-1381.939	-1236.406
51	WRF_VCO_GND1P2	774.273	-2060.194	-774.273	-2060.194
52	WRF_XTAL_CAB_GND1P2	313.252	-1806.777	-313.252	-1806.777
53	WRF_XTAL_CAB_VDD1P2	113.254	-1806.777	-113.254	-1806.777
54	WRF_XTAL_CAB_XON	113.254	-2006.775	-113.254	-2006.775
55	WRF_XTAL_CAB_XOP	313.252	-2006.775	-313.252	-2006.775
56	SR_PVSS	-1875.008	2074.964	1875.008	2074.964
57	SR_PVSS	-1875.008	1874.966	1875.008	1874.966
58	SR_PVSS	-1875.008	1674.968	1875.008	1674.968
59	SR_PVSS	-1875.008	1474.970	1875.008	1474.970
60	SR_PVSS	-1875.008	1274.972	1875.008	1274.972
61	SR_VLX	-1675.010	2074.964	1675.010	2074.964
62	SR_VLX	-1675.010	1874.966	1675.010	1874.966
63	SR_VLX	-1675.010	1674.968	1675.010	1674.968
64	SR_VLX	-1675.010	1474.970	1675.010	1474.970
65	SR_VLX	-1475.012	1874.966	1475.012	1874.966
66	SR_VLX	-1475.012	1674.968	1475.012	1674.968
67	PMU_AVSS	-1475.012	1474.970	1475.012	1474.970
68	PMU_AVSS	-1675.010	1274.972	1675.010	1274.972
69	SR_VDDBATP5V	-1475.012	2074.964	1475.012	2074.964

Not Recommended for New Designs

Table 19: WLCS208–Bump Coordinates (Cont.)

Bump#	Signal Name	Bump Side View (0,0 center of die)		Package Top Side View (0,0 center of die)	
		X	Y	X	Y
70	SR_VddbATP5V	-1275.014	2074.964	1275.014	2074.964
71	SR_VddbATP5V	-1275.014	1874.966	1275.014	1874.966
72	SR_VddbATP5V	-1275.014	1674.968	1275.014	1674.968
73	SR_VddbATP5V	-1275.014	1474.970	1275.014	1474.970
74	SR_VddbATA5V	-1075.016	1474.970	1075.016	1474.970
75	SR_VddbATA5V	-875.018	1474.970	875.018	1474.970
76	VOUt_3P3	-1075.016	2074.964	1075.016	2074.964
77	VOUt_CLDO	-1075.016	1874.966	1075.016	1874.966
78	VOUt_CLDO	-1075.016	1674.968	1075.016	1674.968
79	LDO_VDD1P5	-875.018	2074.964	875.018	2074.964
80	LDO_VDD1P5	-875.018	1874.966	875.018	1874.966
81	LDO_VDD1P5	-875.018	1674.968	875.018	1674.968
82	VOUt_LNLDO	-675.020	2074.964	675.020	2074.964
83	VOUt_HSICLDO	-675.020	1874.966	675.020	1874.966
84	BT_REG_ON	-675.020	1674.968	675.020	1674.968
85	WL_REG_ON	-675.020	1474.970	675.020	1474.970
86	VDDIO_PMU	-1075.016	1274.972	1075.016	1274.972
87	HSIC_AGND1p2PLL	-1316.882	1044.986	1316.882	1044.986
88	HSIC_AVDD1p2PLL_OUT	-308.288	881.600	308.288	881.600
89	HSIC_DATA	-1863.839	772.520	1863.839	772.520
90	HSIC_STROBE	-1862.633	1030.190	1862.633	1030.190
91	RREFHSIC	-1610.156	1031.486	1610.156	1031.486
92	HSIC_PADVDD1p2	97.000	881.600	-97.000	881.600
93	HSIC_DVDD1p2_OUT	-105.725	881.600	105.725	881.600
94	WL_GPIO_0	-377.957	-1991.074	377.957	-1991.074
95	WL_GPIO_1	-338.672	-1742.170	338.672	-1742.170
96	WL_GPIO_2	-592.121	-1861.474	592.121	-1861.474
97	WL_GPIO_3	-670.385	-1621.309	670.385	-1621.309
98	WL_GPIO_4	-441.200	-1509.376	441.200	-1509.376
99	WL_GPIO_5	-842.636	-1839.190	842.636	-1839.190
100	WL_GPIO_6	-658.334	-1363.018	658.334	-1363.018
101	WL_GPIO_7	-776.783	-1138.450	776.783	-1138.450
102	WL_GPIO_8	-914.546	-1347.826	914.546	-1347.826
103	WL_GPIO_9	-921.809	-1600.906	921.809	-1600.906
104	WL_GPIO_10	-1045.496	-1141.960	1045.496	-1141.960

Not Recommended for New Designs

Table 19: WLCSP 208–Bump Coordinates (Cont.)

Bump#	Signal Name	Bump Side View (0,0 center of die)		Package Top Side View (0,0 center of die)	
		X	Y	X	Y
105	WL_GPIO_11	-1173.548	-1389.424	1173.548	-1389.424
106	WL_GPIO_12	-1094.258	-1792.165	1094.258	-1792.165
107	WL_GPIO_13	-1278.317	-1618.699	1278.317	-1618.699
108	WL_GPIO_14	-1332.434	-1868.710	1332.434	-1868.710
109	WL_GPIO_15	-1514.225	-1590.493	1514.225	-1590.493
110	JTAG_SEL	-1581.032	-1834.312	1581.032	-1834.312
111	PA_LIN_CTRL	-952.895	-652.936	952.895	-652.936
112	RF_SW_CTRL_0	-1281.395	-848.002	1281.395	-848.002
113	RF_SW_CTRL_1	-1278.011	-595.192	1278.011	-595.192
114	RF_SW_CTRL_2	-1534.160	-881.041	1534.160	-881.041
115	RF_SW_CTRL_3	-1045.982	-419.512	1045.982	-419.512
116	RF_SW_CTRL_4	-1317.755	-87.493	1317.755	-87.493
117	RF_SW_CTRL_5	-1287.470	-343.642	1287.470	-343.642
118	RF_SW_CTRL_6	-1556.822	-623.596	1556.822	-623.596
119	RF_SW_CTRL_7	-800.687	-10.327	800.687	-10.327
120	RF_SW_CTRL_8	-964.010	178.520	964.010	178.520
121	RF_SW_CTRL_9	-1539.218	-372.262	1539.218	-372.262
122	VDDIO_RF	-791.804	-459.184	791.804	-459.184
123	VDDIO_RF	-791.804	-256.891	791.804	-256.891
124	OTP_VDD33	-1049.186	-166.324	1049.186	-166.324
125	SDIO_CLK	-1100.288	394.079	1100.288	394.079
126	SDIO_CMD	-1223.291	159.818	1223.291	159.818
127	SDIO_DATA_0	-1474.841	184.226	1474.841	184.226
128	SDIO_DATA_1	-1351.442	407.444	1351.442	407.444
129	SDIO_DATA_2	-1643.717	368.906	1643.717	368.906
130	SDIO_DATA_3	-1854.857	228.992	1854.857	228.992
131	VDDIO_SD	-1601.183	-125.806	1601.183	-125.806
132	VDDIO_SD	-1781.903	-18.103	1781.903	-18.103
133	VDD_ISO	-562.799	52.322	562.799	52.322
134	PACKAGEOPTION_0	-1867.196	-1395.688	1867.196	-1395.688
135	PACKAGEOPTION_1	-1665.758	-1391.620	1665.758	-1391.620
136	PACKAGEOPTION_2	-1421.669	-1385.581	1421.669	-1385.581
137	PACKAGEOPTION_3	-1782.461	-1635.583	1782.461	-1635.583
138	VDDC_ISO_1	-69.626	1956.956	69.626	1956.956
139	BT_DEV_WAKE	715.183	651.326	-715.183	651.326

Not Recommended for New Designs

Table 19: WLCSP 208–Bump Coordinates (Cont.)

Bump#	Signal Name	Bump Side View (0,0 center of die)		Package Top Side View (0,0 center of die)	
		X	Y	X	Y
140	BT_GPIO_2	667.627	1486.517	-667.627	1486.517
141	BT_GPIO_3	567.844	855.824	-567.844	855.824
142	BT_GPIO_4	613.663	1808.663	-613.663	1808.663
143	BT_GPIO_5	361.771	733.820	-361.771	733.820
144	BT_I2S_WS	831.301	1679.396	-831.301	1679.396
145	BT_I2S_CLK	201.877	1571.432	-201.877	1571.432
146	BT_I2S_DI	-250.544	1541.453	250.544	1541.453
147	BT_I2S_DO	190.033	1823.603	-190.033	1823.603
148	BT_HOST_WAKE	833.011	1933.061	-833.011	1933.061
149	BT_PCM_CLK	-269.444	1793.471	269.444	1793.471
150	LPO_IN	-29.936	1693.643	29.936	1693.643
151	BT_PCM_OUT	-15.473	1440.320	15.473	1440.320
152	BT_PCM_SYNC	463.066	504.365	-463.066	504.365
153	BT_TM1	690.802	393.845	-690.802	393.845
154	BT_UART_CTS_N	457.252	1349.708	-457.252	1349.708
155	BT_UART_RTS_N	451.735	1616.144	-451.735	1616.144
156	BT_UART_RXD	333.871	1013.531	-333.871	1013.531
157	BT_UART_TXD	205.819	1307.444	-205.819	1307.444
158	BT_PCM_IN	-298.154	1286.816	298.154	1286.816
159	VDDC_ISO_2	422.089	1969.871	-422.089	1969.871
160	CLK_REQ	-312.509	2045.219	312.509	2045.219
161	BT_VDDO	74.500	639.500	-74.500	639.500
162	BT_VDDO	317.680	291.452	-317.680	291.452
163	BT_VDDO	203.560	476.600	-203.560	476.600
164	WL_VDDIO	-748.091	-887.233	748.091	-887.233
165	WL_VDDIO	-954.407	-906.439	954.407	-906.439
166	WL_VDDIO	-1292.078	-1169.455	1292.078	-1169.455
167	BT_VDDC	-87.635	1200.083	87.635	1200.083
168	BT_VDDC	90.997	1083.056	-90.997	1083.056
169	BT_VDDC	137.473	82.526	-137.473	82.526
170	BT_VDDC	351.295	82.526	-351.295	82.526
171	BT_VDDC	551.356	223.304	-551.356	223.304
172	BT_VDDC	568.312	1108.571	-568.312	1108.571
173	BT_VDDC	719.233	103.703	-719.233	103.703
174	BT_VDDC	762.991	970.286	-762.991	970.286

Not Recommended for New Designs

Table 19: WLCSP 208–Bump Coordinates (Cont.)

Bump#	Signal Name	Bump Side View (0,0 center of die)		Package Top Side View (0,0 center of die)	
		X	Y	X	Y
175	WL_VDDC	-1863.614	-2072.695	1863.614	-2072.695
176	WL_VDDC	-1863.614	-1872.652	1863.614	-1872.652
177	WL_VDDC	-1860.833	518.837	1860.833	518.837
178	WL_VDDC	-1660.403	-2072.695	1660.403	-2072.695
179	WL_VDDC	-1413.830	651.497	1413.830	651.497
180	WL_VDDC	-1209.557	651.497	1209.557	651.497
181	WL_VDDC	-676.541	289.013	676.541	289.013
182	WL_VDDC	-676.541	489.578	676.541	489.578
183	WL_VDDC	-542.135	-453.685	542.135	-453.685
184	WL_VDDC	-542.135	-250.618	542.135	-250.618
185	WL_VDDC	-542.135	-657.796	542.135	-657.796
186	WL_VDDC	-469.037	289.013	469.037	289.013
187	WL_VDDC	-469.037	489.578	469.037	489.578
188	WL_VDDC	-309.035	140.576	309.035	140.576
189	VSSC	-1698.581	-1188.112	1698.581	-1188.112
190	VSSC	-1610.579	770.702	1610.579	770.702
191	VSSC	-1496.486	-1135.102	1496.486	-1135.102
192	VSSC	-1210.106	858.245	1210.106	858.245
193	VSSC	-955.703	603.374	955.703	603.374
194	VSSC	-781.427	718.529	781.427	718.529
195	VSSC	-576.137	718.529	576.137	718.529
196	VSSC	-497.342	-976.405	497.342	-976.405
197	VSSC	-483.086	1079.807	483.086	1079.807
198	VSSC	-381.647	-102.262	381.647	-102.262
199	VSSC	-271.244	1079.807	271.244	1079.807
200	VSSC	-98.903	530.618	98.903	530.618
201	VSSC	-92.378	187.115	92.378	187.115
202	VSSC	32.146	-102.262	-32.146	-102.262
203	VSSC	65.266	321.719	-65.266	321.719
204	VSSC	245.671	-102.262	-245.671	-102.262
205	VSSC	453.949	-102.262	-453.949	-102.262
206	VSSC	663.469	-102.262	-663.469	-102.262
207	VSSC	815.848	1210.613	-815.848	1210.613
208	VSSC	887.785	1413.095	-887.785	1413.095

Not Recommended for New Designs

Signal Descriptions

The signal name, type, and description of each pin in the BCM4334 is listed in [Table 20](#). The symbols shown under Type indicate pin directions (I/O = bidirectional, I = input, O = output) and the internal pull-up/pull-down characteristics (PU = weak internal pull-up resistor and PD = weak internal pull-down resistor), if any. See also [Table 21 on page 106](#) for resistor strapping options.



Caution! This WLCSP bump map information applies only to the B series of the BCM4334. For information on the A0/A1 version refer to the previous version of this data sheet.

Table 20: WLBGA and WLCSP Signal Descriptions

WLCSP Bump	WLBGA Ball	Signal Name	Type	Description
WLAN RF Signal Interface				
40	G1	WRF_RFIN_2G	I	2.4G RF input
41	L1	WRF_RFIN_5G	I	5G RF input
42	H1	WRF_RFOUT_2G	O	2.4G RF output
43	K1	WRF_RFOUT_5G	O	5G RF output
33, 34	K2	WRF_G_TSSI_IN	I	2G TSSI input
32	H2	WRF_GPIO_OUT	I/O	Primarily used as the TSSI input for the 5 GHz transmitter.
RF Control Signals				
112	J10	RF_SW_CTRL_0	O	RF switch enable
113	K9	RF_SW_CTRL_1	O	RF switch enable
114	J9	RF_SW_CTRL_2	O	RF switch enable
115	H9	RF_SW_CTRL_3	O	RF switch enable
116	H10	RF_SW_CTRL_4	O	RF switch enable
117	H8	RF_SW_CTRL_5	O	RF switch enable
118	J8	RF_SW_CTRL_6	O	RF switch enable
119	–	RF_SW_CTRL_7	O	RF switch enable
120	–	RF_SW_CTRL_8	O	RF switch enable
121	–	RF_SW_CTRL_9	O	RF switch enable
111	J3	PA_LIN_CTRL	O	External PA linearity control

Not Recommended for New Designs

Table 20: WLPGA and WLCSP Signal Descriptions (Cont.)

WLCSP Bump	WLPGA Ball	Signal Name	Type	Description
SDIO Bus Interface				
125	F10	SDIO_CLK	I	SDIO clock input
126	G10	SDIO_CMD	I/O	SDIO command line
127	G9	SDIO_DATA_0	I/O	SDIO data line 0
128	F9	SDIO_DATA_1	I/O	SDIO data line 1. Also used as a strapping option (see Table 21 on page 106).
129	G8	SDIO_DATA_2	I/O	SDIO data line 2. Also used as a strapping option (see Table 21 on page 106).
130	E8	SDIO_DATA_3	I/O	SDIO data line 3. Also used for the JTAG TDI signal when JTAG mode is selected with the JTAG_SEL pin.
<p>Note: Per Section 6 of the SDIO specification, 10 to 100 kohm pull-ups are required on the four DATA lines and the CMD line. This requirement must be met during all operating states by using external pull-up resistors or properly programming internal SDIO Host pull-ups. The BCM4334 does not have internal pull-ups on these lines.</p>				
JTAG Interface				
110	L8	JTAG_SEL	I/O	<p>JTAG select:</p> <p>Connect this pin high (VDDIO) in order to use WL_GPIO_2 through WL_GPIO_5 and GPIO_12 as JTAG signals.</p> <p>Note: See “WLAN GPIO Interface” for the JTAG signal pins.</p> <p>Note: If JTAG is not needed, it is recommend that this pin be grounded. If GPIOs 2 through 5 and 12 are not used and JTAG is not needed, then this pin can be a No_Connect.</p>
HSIC Interface				
90	D10	HSIC_STROBE	I	HSIC Strobe
89	E10	HSIC_DATA	I/O	HSIC Data
91	E9	RREFHSIC	I	HSIC reference resistor input. If HSIC is used, connect this pin to ground via a 51Ω 5% resistor.
WLAN GPIO Interface				
94	J4	WL_GPIO_0/ WL_HOST_WAKE	I/O	This pin can be programmed by software to be a GPIO or a WLAN_HOST_WAKE output indicating that host wake-up should be performed.

Table 20: WLPGA and WLCSP Signal Descriptions (Cont.)

WLCSP Bump	WLPGA Ball	Signal Name	Type	Description
95	J5	WL_GPIO_1/ WL_DEV_WAKE	I/O	This pin can be programmed by software to be a GPIO or an AP_READY or HSIC_HOST_READY input from the host indicating that it is awake. This pin is also used as an out-of-band wake-up when the host wants to wake WLAN from the deep sleep mode.
96	H6	WL_GPIO_2/ TCK/ ERCX_STATUS	I/O	This pin can be programmed by software to be a GPIO, the JTAG TCK signal, the external coexistence ERCX_STATUS signal, or an HSIC_READY output to the host, indicating that the device is ready to respond with a CONNECT when it sees IDLE on the HSIC bus.
97	G6	WL_GPIO_3/ TMS/ ERCX_FREQ	I/O	This pin can be programmed by software to be a GPIO or the JTAG TMS signal, or the external coexistence ERCX_FREQ signal.
98	H7	WL_GPIO_4/ TDI/ UART_RX/ ERCX_RF_ACTIVE	I/O	This pin can be programmed by software to be a GPIO, the JTAG TDI signal or the UART Rx signal, or the external coexistence ERCX_RF_ACTIVE signal.
99	L9	WL_GPIO_5/ TDO/ UART_TX/ ERCX_TXCONF	I/O	This pin can be programmed by software to be a GPIO, the JTAG TDO signal or the UART Tx signal, or the external coexistence ERCX_TXCONF signal.
100	J6	WL_GPIO_6/ SPI_MODE_SEL	I/O	WL_GPIO_6. Also used as SPI_MODE_SEL strapping option (see Table 21 on page 106).
106	J7	WL_GPIO_12/ JTAG_TRST_L/ ERCX_PRISEL	I/O	This pin can be programmed by software to be a GPIO or the JTAG TRST_L signal, or the external coexistence ERCX_PRISEL signal. WL_GPIO 12 has an internal pull-down by default if JTAG_SEL is low. When JTAG_SEL is high, WL_GPIO 12 is used as JTAG_TRST_L and is pulled up.
101	–	WL_GPIO_7	I/O	GPIO/Debug pins. Note: These are also used as strapping options (see Table 21 on page 106).
102	–	WL_GPIO_8	I/O	–
107	–	WL_GPIO_13	I/O	–
103	–	WL_GPIO_9	I/O	–
104	–	WL_GPIO_10	I/O	–

Not Recommended for New Designs

Table 20: WLPGA and WLCSP Signal Descriptions (Cont.)

WLCSP Bump	WLPGA Ball	Signal Name	Type	Description
105	–	WL_GPIO_11	I/O	–
108	–	WL_GPIO_14	I/O	–
109	–	WL_GPIO_15	I/O	–
Clocks				
55	L5	WRF_XTAL_CAB_OP	I	XTAL oscillator input
54	L6	WRF_XTAL_CAB_ON	O	XTAL oscillator output
48	L7	WRF_TCXO_CKIN2V	I	TCXO buffered input. When not using a TCXO this pin should be connected to ground.
160	A6	CLK_REQ	O	XTAL clock request — shared by BT and WLAN
150	B6	LPO_IN	I	External sleep clock input (32.768 kHz)
Bluetooth/FM Receiver				
21	E1	BT_RF	I/O	Bluetooth transceiver RF antenna port
1	B1	FM_RFIN	I	FM radio antenna port
5	–	FM_RFAUX	I	FM radio auxiliary antenna port
Bluetooth PCM				
149	C7	BT_PCM_CLK	I/O	PCM clock; can be master (output) or slave (input)
158	D7	BT_PCM_IN	I	PCM data input sensing
151	E7	BT_PCM_OUT	O	PCM data output
152	C4	BT_PCM_SYNC	I/O	PCM sync; can be master (output) or slave (input)
Bluetooth UART				
154	D4	BT_UART_CTS_N	I	UART clear-to-send. Active-low clear-to-send signal for the HCI UART interface.
155	E4	BT_UART_RTS_N	O	UART request-to-send. Active-low request-to-send signal for the HCI UART interface.
156	B5	BT_UART_RXD	I	UART serial input. Serial data input for the HCI UART interface.
157	E5	BT_UART_TXD	O	UART serial output. Serial data output for the HCI UART interface.

Not Recommended for New Designs

Table 20: WLPGA and WLCSP Signal Descriptions (Cont.)

WLCSP Bump	WLPGA Ball	Signal Name	Type	Description
Bluetooth/FM I²S				
145	F6	BT_I2S_CLK	I/O	I ² S clock; can be master (output) or slave (input)
147	F5	BT_I2S_DO	I/O	I ² S data output
144	G5	BT_I2S_WS	I/O	I ² S WS; can be master (output) or slave (input)
146	E6	BT_I2S_DI	I/O	I ² S data input
Bluetooth Test Mode				
153	–	BT_TM1	I/O	ARMJTAGMode
Bluetooth GPIO				
140	–	BT_GPIO_2	I/O	WiMAX coexistence interface
141	–	BT_GPIO_3	I/O	WiMAX coexistence interface
142	–	BT_GPIO_4	I/O	WiMAX coexistence interface
143	–	BT_GPIO_5	I/O	WiMAX coexistence interface
Miscellaneous				
85	A4	WL_REG_ON	I	Used by PMU to power up or power down the internal BCM4334 regulators used by the WLAN section. Also, when deasserted, this pin holds the WLAN section in reset. This pin has an internal 200 k Ω pull-down resistor that is enabled by default. It can be disabled through programming.
84	A5	BT_REG_ON	I	Used by PMU to power up or power down the internal BCM4334 regulators used by the Bluetooth/FM section. Also, when deasserted, this pin holds the Bluetooth/FM section in reset. This pin has an internal 200 k Ω pull-down resistor that is enabled by default. It can be disabled through programming.
139	B4	BT_DEV_WAKE/ BT_GPIO_0	I/O	DEV_WAKE or general-purpose I/O signal
148	F4	BT_HOST_WAKE/ BT_GPIO_1	I/O	HOST_WAKE or general-purpose I/O signal

Not Recommended for New Designs

Table 20: WLBGA and WLCSP Signal Descriptions (Cont.)

WLCSP Bump	WLBGA Ball	Signal Name	Type	Description
Integrated Voltage Regulators				
74, 75	B9	SR_VDDBATA5V	I	Quiet VBAT
69–73	A9	SR_VDDBATP5V	I	Power VBAT
61–66	B10	SR_VLX	O	Cbuck switching regulator output. See Table 41 on page 143 for details of the inductor and capacitor required on this output.
79–81	A8	LDO_VDD1P5	I	LNLDO input
82	A7	VOUT_LNLDO	O	Output of low-noise LNLDO
77, 78	B8	VOUT_CLDO	O	Output of core LDO
76	B7	VOUT_3P3	O	LDO3p3 output
83	–	VOUT_HSICLDO	I	HSIC LDO output
Bluetooth Power Supplies				
17	–	BT_PAVDD	I	Bluetooth PA power supply
15	D1	BT_LNAVDD	I	Bluetooth LNA power supply
13	D3	BT_IFVDD	I	Bluetooth IF block power supply
19	D2	BT_PLLVDD	I	Bluetooth RF PLL power supply
23	C1	BT_VCOVDD	I	Bluetooth RF power supply
138	–	VDDC_ISO_1	I	Core supply for power-on/off island VDDC_G
159	–	VDDC_ISO_2	I	Core supply for power-on/off island VDDB
11	–	BT_LDO_OUT	O	2.5V Bluetooth LDO output
–	F1	BT_LDOPAVDD2P5	I/O	2.5V BT LDO output and Bluetooth PA power supply
22	F2	BT_VDDBAT	I	VBAT for Bluetooth
FM Receiver Power Supplies				
8	–	FM_VCOVDD	I	FM VCO supply
4	–	FM_LNAVDD	I	FM receiver power supply
–	A1	FM_LNAVCOVDD	I	FM VCO and receiver power supply
7	A3	FM_PLLVDD	I	FM PLL power supply
2	–	FM_IFVDD	I	FM IF power supply

Table 20: WLBGA and WLCSP Signal Descriptions (Cont.)

WLCSP Bump	WLBGA Ball	Signal Name	Type	Description
WLAN Power Supplies				
–	H4	WRF_BUCK_VDD1P5	I	Internal capacitor-less LDO input supply
47	K5	WRF_SYNTH_VDD1P2	I	Synth VDD 1.2V input
39	J1	WRF_PADRV_VBAT_VDD5P0	I	PA Driver VBAT supply
53	K6	WRF_XTAL_CAB_VDD1P2	I	XTAL oscillator supply
49	K7	WRF_TCXO_VDD1P8	I	Supply to the WRF_TCXO_CKIN input buffer. When not using a TCXO, this pin should be connected to ground.
31	–	WRF_BUCK_VCO_VDD1P5	I	Internal LDO input supply (from CBUCK)
28	–	WRF_BUCK_AFE_VDD1P5	I	Internal AFE LDO input supply (from CBUCK)
29	–	WRF_BUCK_RX_VDD1P5	I	Internal LDO input supply (from CBUCK)
30	–	WRF_BUCK_TX_VDD1P5	I	Internal LDO input supply (from CBUCK)
Miscellaneous Power Supplies				
124	–	OTP_VDD33	I	OTP 3.3V supply
167–174, 175–188	C6, D6, F7, L10	VDDC	I	Core supply for WLAN and BT.
133	–	VDD_ISO	I	Core supply for the Power On/Off island
86, 164–166	C8, G7	VDDIO	I	IO supply (1.8–3.3V) for PMU controls and WLAN. Must be directly connected to BT_VDDO on the PCB. Labeled VDDIO_PMU on WLCSP documentation.
161–163	–	BT_VDDO	I	IO supply (1.8–3.3V) for BT. Must be directly connected to VDDIO_PMU and WL_VDDIO on the PCB.
131, 132	–	VDDIO_SD	I	IO supply for SDIO pads (1.8-3.3V)
122, 123	K10	VDDIO_RF	I/O	IO supply for RF switch control pads (3.3V)
88	–	HSIC_AVDD1p2PLL_OUT	O	1.2V supply for HSIC PLL
92	–	HSIC_PADVDD1p2	I	1.2V supply for HSIC PA. This pin can be NO_CONNECT when HSIC is not used.
93	D8	HSIC_DVDD1p2_OUT	O	1.2V supply for HSIC interface. This pin can be NO_CONNECT when HSIC is not used.
Ground				

Not Recommended for New Designs

Table 20: WLBGA and WLCSP Signal Descriptions (Cont.)

WLCSP Bump	WLBGA Ball	Signal Name	Type	Description
46	K4	WRF_SYNTH_GND1P2	I	Synth ground
51	L3	WRF_VCO_GND1P2	I	VCO/logen gnd
25–27	G4	WRF_AFE_GND1P2	I	AFE ground
35	–	WRF_LDO_GND1P5	I	LDO Ground
36	G2	WRF_LNA_2G_GND1P2	I	2 GHz internal LNA ground
37	L2	WRF_LNA_5G_GND1P2	I	5 GHz internal LNA ground
–	G3	WRF_RX_GND1P2	I	RX ground
50	H3	WRF_TX_GND1P2	I	TX ground
38	J2	WRF_PADRV_VBAT_GND5P0	I	PAD ground
52	L4	WRF_XTAL_CAB_GND1P2	I	XTAL ground
44	–	WRF_RX2G_GND1P2	I	RX2G ground
45	–	WRF_RX5G_GND1P2	I	RX5G ground
12	F3	BT_LDOVSS	I	Bluetooth PA and LDO ground. Labeled BT_PALDO_VSS on WLCSP documentation.
189–208	C5, C9, D5, F8, K8	VSSC	I	Core ground for WLAN and BT
56–60	A10	SR_PVSS	I	Power Gnd
67 and 68	C10	PMU_AVSS	I	Quiet Gnd
87	D9	AGND12PLL/ HSIC_AGND1p2PLL	I	HSIC PLL ground
18	E2	BT_PAVSS	I	Bluetooth PA ground
16	–	BT_LNAVSS	I	Bluetooth LNA ground
14	E3	BT_IFVSS	I	1.2V Bluetooth IF block ground
20	C3	BT_PLLVSS	I	Bluetooth RF PLL ground
24	C2	BT_VCOVSS	I	1.2V Bluetooth RF ground
10	A2	FM_VCOVSS	I	FM VCO ground
3	B2	FM_LNAVSS	I	FM receiver ground
9	B3	FM_PLLVSS	I	FM PLL ground
6	–	FM_IFVSS	I	FM IF ground
134	–	PACKAGEOPTION_0	O	PAD ground
135	–	PACKAGEOPTION_1	O	PAD ground
136	–	PACKAGEOPTION_2	O	PAD ground
137	–	PACKAGEOPTION_3	O	PAD ground
No Connect				
–	–	–	–	–

Not Recommended for New Designs

WLAN GPIO Signals and Strapping Options

The pins listed in [Table 21](#) are sampled at power-on reset (POR) to determine the various operating modes. Sampling occurs a few milliseconds after an internal POR or deassertion of the external POR. After the POR, each pin assumes the GPIO or alternative function specified in the signal descriptions table. Each strapping option pin has an internal pull-up (PU) or pull-down (PD) resistor that determines the default mode. To change the mode, connect an external PU resistor to VDDIO or a PD resistor to GND, using a 10 kΩ resistor or less.



Note: Refer to the reference board schematics for more information.

Table 21: WLAN GPIO Functions and Strapping Options (Advance Information)

<i>Pin Name</i>	<i>WLCSP Pin #</i>	<i>WLBGA Pin #</i>	<i>Default</i>	<i>Function</i>	<i>Description</i>
SDIO_DATA_1	128	F9	N/A ^a	strap_host_ifc_1	The three strap pins strap_host_ifc_[3:1] select the host interface ^b to enable: <ul style="list-style-type: none"> • 0XX: SDIO • 10X: gSPI • 110: normal HSIC • 111: bootloader-less HSIC
SDIO_DATA_2	129	G8	N/A ^a	strap_host_ifc_2	<ul style="list-style-type: none"> • 0: select gSPI mode • 1: select SDIO mode
WL_GPIO_6/ SPI_MODE_SEL	100	J6	0	strap_host_ifc_3	<ul style="list-style-type: none"> • 0: select SDIO mode • 1: select HSIC mode
WL_GPIO_7	101	–	1	OTPEnabled	This strapping option selects the use of OTP or the default CIS in the SDIO core as described in Table 22 .
WL_GPIO_8	102	–	1	LPOAutoDetEn	This strapping option selects the enable of LPO auto-detection circuit. <ul style="list-style-type: none"> • 0: The LPOSelect strapping option determines the source of the ILP clock. • 1: The LPOSelect strapping option is ignored and the external LPO is selected if it is detected; otherwise, the internal LPO is used.

Not Recommended for New Designs

Table 21: WLAN GPIO Functions and Strapping Options (Advance Information) (Cont.)

Pin Name	WLCSP Pin #	WLBGA Pin #	Default	Function	Description
WL_GPIO_9	103	–	1	ARM Remap[0]	<ul style="list-style-type: none"> 0: Boot from SRAM, ARM held in reset. 1: Boot from ROM by remapping the ARM core exception vectors there, ARM running out of reset.
WL_GPIO_10	104	–	0	Use SPROM	<ul style="list-style-type: none"> When set =1 this pin selects the use of an external SPROM multiplexed onto the GPIO lines. WL_GPIO_8 = clk WL_GPIO_9 = cs WL_GPIO_10 = input data from SPROM WL_GPIO_11 = data output to SPROM
WL_GPIO_11	105	–	0	IlpDivEn	<ul style="list-style-type: none"> 0: Select external sleep clock or LPO clock (based on the value on LPOSelect strap) as ILP clock. 1: Select the clock derived by dividing the ALP clock by IlpDiv. If this field is set to 1, the ResourceInitMode option must be set to 10 for ALP clock available.
WL_GPIO_13	107	–	0	LPOSelect	<ul style="list-style-type: none"> 0: Select external sleep clock as ILP clock. 1: Select internal LPO clock. This value is ignored if the LPOAutoDetEn option is set to 1.

Not Recommended for New Designs

Table 21: WLAN GPIO Functions and Strapping Options (Advance Information) (Cont.)

Pin Name	WLCSP Pin #	WLBGA Pin #	Default	Function	Description
WL_GPIO_15, WL_GPIO_14	109, 108	–	10	ResourceInitMode[1:0]	<ul style="list-style-type: none"> • 00: for PMU to power up to ILP clock available (no backplane clock) • 01: power up to ILP clock request • 10: ALP clock available. • 11: HT clock available. This field must be set to 10 for ALP clock available if IlpDivEn strap is set to 1. This field may not be set to 11 for implementations using an oscillator running at other than 37.4 MHz because the PLL must be reprogrammed before it is enabled.
JTAG_SELECT	110	L8	N/A	JTAG select	<ul style="list-style-type: none"> • Connect this pin high (VDDIO) in order to use WL_GPIO_2 through WL_GPIO_5 and WL_GPIO_12 as JTAG signals. <p>Note: See “WLAN GPIO Interface” for the JTAG signal pins. Note: If JTAG is not needed, it is recommend that this pin be grounded. If GPIOs 2 through 5 and 12 are not used and JTAG is not needed, then this pin can be a No_Connect.</p>

- a. The SDIO_DATA_1 and SDIO_DATA_2 pins have unknown default states because they are not attached to internal pulls. Pull these pins high or low to select the appropriate mode. If the pins are not used after strapping (such as in HSIC mode), then they can be tied directly to VDDIO or GND without a resistor.
- b. The unused host interface is tristated. However, the SDIO lines have internal pulls activated when in HSIC mode (see Table 25: “I/O States,” on page 112). There are no bus-keepers on the HSIC interface when it is not in use.

Not Recommended for New Designs

Table 22: OTP Select

Use SPROM	OTPEnabled	CIS Source	OTP State	ChipID Source
0	0	Default	OFF	Default
0	1	OTP if programmed, else default	ON	OTP if programmed, else default
1	0	SPROM	OFF	Default
1	1	SPROM	ON	OTP if programmed, else default

Not Recommended for New Designs

Multiplexed Bluetooth GPIO Signals

The Bluetooth GPIO pins (BT_GPIO_0 to BT_GPIO_7) are multiplexed pins and can be programmed to be used as GPIOs or for other Bluetooth interface signals such as I²S. The specific function for a given BT_GPIO_X pin is chosen by programming the Pad Function Control Register for that specific pin. Table 23 shows the possible options for each BT_GPIO_X pin. Note that each BT_GPIO_X pin's Pad Function Control Register Setting is independent (BT_GPIO_1 can be set to Pad Function 7 at the same time that BT_GPIO_3 is set to PAD Function 0). When the Pad Function Control Register is set to 0, the BT_GPIOs do not have specific functions assigned to them and behave as generic GPIOs. The A_GPIO_X pins described below are multiplexed behind the BCM4334's PCM and I²S interface pins.

Table 23: GPIO Multiplexing Matrix

Name	Pad Function Control Register Setting							
	0	1	2	3	4	5	6	7
BT_UART_CTS_N	UART_CTS_N	–	–	–	–	–	–	A_GPIO[1]
BT_UART_RTS_N	UART_RTS_N	–	–	–	–	–	–	A_GPIO[0]
BT_UART_RXD	UART_RXD	–	–	–	–	–	–	GPIO[5]
BT_UART_TXD	UART_TXD	–	–	–	–	–	–	GPIO[4]
BT_PCM_IN	A_GPIO[3]	PCM_IN	PCM_IN	HCLK	–	–	–	I2S_SSDI/MSDI
BT_PCM_OUT	A_GPIO[2]	PCM_OUT	PCM_OUT	LINK_IND	–	I2S_MSDO	–	I2S_SSDO
BT_PCM_SYNC	A_GPIO[1]	PCM_SYNC	PCM_SYNC	HCLK	INT_LPO	I2S_MWS	–	I2S_SWS
BT_PCM_CLK	A_GPIO[0]	PCM_CLK	PCM_CLK	–	–	I2S_MSCK	–	I2S_SSCK
BT_I2S_DO	A_GPIO[5]	PCM_OUT	–	–	I2S_SSDO	I2S_MSDO	–	STATUS
BT_I2S_DI	A_GPIO[6]	PCM_IN	–	HCLK	I2S_SSDI/ MSDI	–	–	TX_CON_FX
BT_I2S_WS	GPIO[7]	PCM_SYNC	–	LINK_IND	–	I2S_MWS	–	I2S_SWS
BT_I2S_CLK	GPIO[6]	PCM_CLK	–	–	INT_LPO	I2S_MSCK	–	I2S_SSCK
BT_GPIO_5 ^a	GPIO[5]	HCLK	–	I2S_MSCK	I2S_SSCK	–	–	CLK_REQ
BT_GPIO_4 ^a	GPIO[4]	LINK_IND	–	I2S_MSDO	I2S_SSDO	–	–	–
BT_GPIO_3 ^a	GPIO[3]	–	–	I2S_MWS	I2S_SWS	–	–	–
BT_GPIO_2 ^a	GPIO[2]	–	–	–	I2S_SSDI/ MSDI	–	–	–
BT_GPIO_1	GPIO[1]	–	–	–	–	–	–	CLASS1[2]
BT_GPIO_0	GPIO[0]	–	–	–	clk_12p288	–	–	–
CLK_REQ	WL/BT_CLK_REQ	–	–	–	–	–	–	A_GPIO[7]

a. Available only in the WLCSF package.

Not Recommended for New Designs

The multiplexed GPIO signals are described in [Table 24](#).

Table 24: Multiplexed GPIO Signals

Pin Name	Type	Description
UART_CTS_N	I	Host UART clear to send
UART_RTS_N	O	Device UART request to send
UART_RXD	I	Device UART receive data
UART_TXD	O	Host UART transmit data
PCM_IN	I	PCM data input
PCM_OUT	O	PCM data output
PCM_SYNC	I/O	PCM sync signal, can be master (output) or slave (input)
PCM_CLK	I/O	PCM clock, can be master (output) or slave (input)
GPIO[7:0]	I/O	General purpose I/O
A_GPIO[7:0]	I/O	A group general purpose I/O
I2S_MSDO	O	I ² S master data output
I2S_MWS	O	I ² S master word select
I2S_MSCK	O	I ² S master clock
I2S_SSCK	I	I ² S slave clock
I2S_SSDO	O	I ² S slave data output
I2S_SWS	I	I ² S slave word select
I2S_SSDI/MSDI	I	I ² S slave/master data input
STATUS	O	Signals Bluetooth priority status
TX_CON_FX	I	WLAN-BT coexist. Transmission confirmation; permission for BT to transmit
RF_ACTIVE	O	WLAN-BT coexist. Asserted (logic high) during local BT RX and TX slots
LINK_IND	O	BT receiver/transmitter link indicator
CLK_REQ	O	WLAN/BT clock request output

Not Recommended for New Designs

I/O States

The following notations are used in [Table 25](#):

- I: Input signal
- O: Output signal
- I/O: Input/Output signal
- PU = Pulled up
- PD = Pulled down
- NoPull = Neither pulled up nor pulled down

Table 25: I/O States

Name	I/O	Keeper	Active Mode	Low Power State/ Sleep (All Power Present)	Power-down (BT_REG_ON and WL_REG_ON Held Low)	Out-of-Reset; Before SW Download (BT_REG_ON=1; WL_REG_ON=1)	(WL_REG_ON=1 and BT_REG_ON=0) and VDDIOs Are Present	(WL_REG_ON=0 and BT_REG_ON=1) and VDDIOs Are Present	Power Rail
WL_REG_ON	I	N	Input; PD (pull-down can be disabled)	Input; PD (pull-down can be disabled)	Input; PD (of 200K)	Input; PD (of 200 kΩ)	Input; PD (of 200 kΩ)	Input; PD (pull-down can be disabled)	–
BT_REG_ON	I	N	Input; PD (pull down can be disabled)	Input; PD (pull down can be disabled)	Input; PD (of 200K)	Input; PD (of 200 kΩ)	Input; PD (of 200 kΩ)	Input; PD (pull down can be disabled)	–
CLK_REQ	I/O	Y	Open drain or push- pull (programmable). Active high.	Open drain or push- pull (programmable). Active high	PD	Open drain. Active high.	Open drain. Active high.	–	BT_VDDO
BT_HOST_ WAKE	I/O	Y	I/O; PU, PD, NoPull (programmable)	I/O; PU, PD, NoPull (programmable)	High-Z, NoPull	Input, PD	Input, PD	I/O; PU, PD, NoPull (programmable)	BT_VDDO
BT_DEV_WAKE	I/O	Y	I/O; PU, PD, NoPull (programmable)	Input; PU, PD, NoPull (programmable)	High-Z, NoPull	Input, PD	Input, PD	I/O; PU, PD, NoPull (programmable)	BT_VDDO
BT_GPIO2– BT_GPIO5	I/O	Y	I/O; PU, PD, NoPull (programmable)	I/O; PU, PD, NoPull (programmable)	High-Z, NoPull	Input, PD	Input, PD	I/O; PU, PD, NoPull (programmable)	BT_VDDO
BT_UART_CTS	I	Y	Input; NoPull	Input; NoPull	High-Z, NoPull	Input; PU	Input; PU	Input; NoPull	BT_VDDO
BT_UART_RTS	O	Y	Output; NoPull	Output; NoPull	High-Z, NoPull	Input; PU	Input; PU	Output; NoPull	BT_VDDO
BT_UART_RXD	I	Y	Input; PU	Input; NoPull	High-Z, NoPull	Input; PU	Input; PU	Input; PU	BT_VDDO
BT_UART_TXD	O	Y	Output; NoPull	Output; NoPull	High-Z, NoPull	Input; PU	Input; PU	Output; NoPull	BT_VDDO

Table 25: I/O States (Cont.)

Name	I/O	Keeper	Active Mode	Low Power State/ Sleep (All Power Present)	Power-down (BT_REG_ON and WL_REG_ON Held Low)	Out-of-Reset; Before SW Download (BT_REG_ON=1; WL_REG_ON=1)	(WL_REG_ON=1 and BT_REG_ON=0) and VDDIOs Are Present	(WL_REG_ON=0 and BT_REG_ON=1) and VDDIOs Are Present	Power Rail
SDIO_DATA_0	I/O	N	HSIC MODE = PU; SDIO MODE = NoPull	HSIC MODE = PU; SDIO MODE = NoPull	HSIC MODE = NoPull; SDIO MODE = NoPull	HSIC MODE = PU; SDIO MODE = NoPull	HSIC MODE = PU; SDIO MODE = NoPull	HSIC MODE = NoPull; SDIO MODE = Driven Low	WL_VDDIO
SDIO_DATA_1	I/O	N	HSIC MODE = PD; SDIO MODE = NoPull	HSIC MODE = PD; SDIO MODE = NoPull	HSIC MODE = NoPull; SDIO MODE = NoPull	HSIC MODE = PD; SDIO MODE = NoPull	HSIC MODE = PD; SDIO MODE = NoPull	HSIC MODE = NoPull; SDIO MODE = NoPull	WL_VDDIO
SDIO_DATA_2	I/O	N	HSIC MODE = PU; SDIO MODE = NoPull	HSIC MODE = PU; SDIO MODE = NoPull	HSIC MODE = NoPull; SDIO MODE = NoPull	HSIC MODE = PU; SDIO MODE = NoPull	HSIC MODE = PU; SDIO MODE = NoPull	HSIC MODE = NoPull; SDIO MODE = NoPull	WL_VDDIO
SDIO_DATA_3	I/O	N	HSIC MODE = PU; SDIO MODE = NoPull	HSIC MODE = PU; SDIO MODE = NoPull	HSIC MODE = NoPull; SDIO MODE = NoPull	HSIC MODE = PU; SDIO MODE = NoPull	HSIC MODE = PU; SDIO MODE = NoPull	HSIC MODE = NoPull; SDIO MODE = Driven Low	WL_VDDIO
SDIO_CMD	I/O	N	HSIC MODE = PU; SDIO MODE = NoPull	HSIC MODE = PU; SDIO MODE = NoPull	HSIC MODE = NoPull; SDIO MODE = NoPull	HSIC MODE = PU; SDIO MODE = NoPull	HSIC MODE = PU; SDIO MODE = NoPull	HSIC MODE = NoPull; SDIO MODE = Driven Low	WL_VDDIO
SDIO_CLK	I	N	HSIC MODE = PD; SDIO MODE = NoPull	HSIC MODE = PD; SDIO MODE = NoPull	HSIC MODE = NoPull; SDIO MODE = NoPull	HSIC MODE = PD; SDIO MODE = NoPull	HSIC MODE = PD; SDIO MODE = NoPull	HSIC MODE = NoPull; SDIO MODE = NoPull	WL_VDDIO
BT_PCM_CLK	I/O	Y	Input; NoPull (Note 4)	Input; NoPull (Note 4)	High-Z, NoPull	Input, PD	Input, PD	Input; NoPull (Note 4)	BT_VDDO
BT_PCM_IN	I/O	Y	Input; NoPull (Note 4)	Input; NoPull (Note 4)	High-Z, NoPull	Input, PD	Input, PD	Input; NoPull (Note 4)	BT_VDDO
BT_PCM_OUT	I/O	Y	Input; NoPull (Note 4)	Input; NoPull (Note 4)	High-Z, NoPull	Input, PD	Input, PD	Input; NoPull (Note 4)	BT_VDDO
BT_PCM_SYNC	I/O	Y	Input; NoPull (Note 4)	Input; NoPull (Note 4)	High-Z, NoPull	Input, PD	Input, PD	Input; NoPull (Note 4)	BT_VDDO
BT_I2S_WS	I/O	Y	Input; NoPull (Note 5)	Input; NoPull (Note 5)	High-Z, NoPull	Input, PD	Input, PD	Input; NoPull (Note 5)	BT_VDDO
BT_I2S_CLK	I/O	Y	Input; NoPull (Note 5)	Input; NoPull (Note 5)	High-Z, NoPull	Input, PD	Input, PD	Input; NoPull (Note 5)	BT_VDDO
BT_I2S_DI	I/O	Y	Input; NoPull (Note 5)	Input; NoPull (Note 5)	High-Z, NoPull	Input, PD	Input, PD	Input; NoPull (Note 5)	BT_VDDO
BT_I2S_DO	I/O	Y	Input; NoPull (Note 5)	Input; NoPull (Note 5)	High-Z, NoPull	Input, PD	Input, PD	Input; NoPull (Note 5)	BT_VDDO
JTAG_SEL	I	Y	NoPull	NoPull	NoPull	NoPull	NoPull	NoPull	WL_VDDIO
WL_GPIO_0	I/O	Y	PD	PD	NoPull	PD	PD	NoPull	WL_VDDIO
WL_GPIO_1	I/O	Y	NoPull	NoPull	NoPull	NoPull	NoPull	NoPull	WL_VDDIO
WL_GPIO_2	I/O	Y	PU	PU	NoPull	PU	PU	PU	WL_VDDIO
WL_GPIO_3	I/O	Y	JTAG_SEL = 1 PU; jtag_sel=0 PD	jtag_sel=1 PU; jtag_sel=0 PD	NoPull	jtag_sel=1 PU; jtag_sel=0 PD	jtag_sel=1 PU; jtag_sel=0 PD	PU	WL_VDDIO
WL_GPIO_4	I/O	Y	jtag_sel=1 PU; jtag_sel=0 PD	jtag_sel=1 PU; jtag_sel=0 PD	NoPull	jtag_sel=1 PU; jtag_sel=0 PD	jtag_sel=1 PU; jtag_sel=0 PD	PU	WL_VDDIO

Not Recommended for New Designs

Table 25: I/O States (Cont.)

<i>Name</i>	<i>I/O</i>	<i>Keeper</i>	<i>Active Mode</i>	<i>Low Power State/ Sleep (All Power Present)</i>	<i>Power-down (BT_REG_ON and WL_REG_ON Held Low)</i>	<i>Out-of-Reset; Before SW Download (BT_REG_ON=1; WL_REG_ON=1)</i>	<i>(WL_REG_ON=1 and BT_REG_ON=0) and VDDIOs Are Present</i>	<i>(WL_REG_ON=0 and BT_REG_ON=1) and VDDIOs Are Present</i>	<i>Power Rail</i>
WL_GPIO_5	I/O	Y	NoPull	NoPull	NoPull	NoPull	NoPull	NoPull	WL_VDDIO
WL_GPIO_6	I/O	Y	PD	PD	NoPull	PD	PD	NoPull	WL_VDDIO
WL_GPIO_7	I/O	Y	PU	PU	NoPull	PU	PU	NoPull	WL_VDDIO
WL_GPIO_8	I/O	Y	PU	PU	NoPull	PU	PU	PU	WL_VDDIO
WL_GPIO_9	I/O	Y	PU	PU	NoPull	PU	PU	NoPull	WL_VDDIO
WL_GPIO_10	I/O	Y	PD	PD	NoPull	PD	PD	NoPull	WL_VDDIO
WL_GPIO_11	I/O	Y	PD	PD	NoPull	PD	PD	PD	WL_VDDIO
WL_GPIO_12	I/O	Y	jtag_sel=1 PU; jtag_sel=0 PD	jtag_sel=1 PU; jtag_sel=0 PD	NoPull	jtag_sel=1 PU; jtag_sel=0 PD	jtag_sel=1 PU; jtag_sel=0 PD	PU	WL_VDDIO
WL_GPIO_13	I/O	Y	PD	PD	NoPull	PD	PD	PD	WL_VDDIO
WL_GPIO_14	I/O	Y	PD	PD	NoPull	PD	PD	NoPull	WL_VDDIO
WL_GPIO_15	I/O	Y	PU	PU	NoPull	PU	PU	NoPull	WL_VDDIO
RF_SW_CTRL_X	O	N	Output; no pulls	Output; no pulls	High-Z	Output; no pulls	Output; no pulls	Output; no pulls	VDDIO_RF

Not Recommended for New Designs

Table 25: I/O States (Cont.)

Name	I/O	Keeper	Active Mode	Low Power State/ Sleep (All Power Present)	Power-down (BT_REG_ON and WL_REG_ON Held Low)	Out-of-Reset; Before SW Download (BT_REG_ON=1; WL_REG_ON=1)	(WL_REG_ON=1 and BT_REG_ON=0) and VDDIOs Are Present	(WL_REG_ON=0 and BT_REG_ON=1) and VDDIOs Are Present	Power Rail
------	-----	--------	-------------	--	--	--	--	--	---------------

Note:

1. Keeper column: N=pad has no keeper. Y=pad has a keeper. Keeper is always active except in Power-down state.
2. If there is no keeper, and it is an input and there is Nopull, then the pad should be driven to prevent leakage due to floating pad (e.g., SDIO_CLK).
3. In the Power-down state (xx_REG_ON=0): High-Z; NoPull => the pad is disabled because power is not supplied.
4. Depending on whether the PCM interface is enabled and the configuration of PCM is in master or slave mode, it can be either output or input.
5. Depending on whether the I²S interface is enabled and the configuration of I²S is in master or slave mode, it can be either output or input.
6. GPIO_6 through GPIO_15 (excluding GPIO_12) are input-only during the Low-Power and Deep-Sleep modes.
7. GPIO_0 through GPIO_5 and GPIO_12 can be configured to operate as inputs or outputs in Deep-Sleep mode before entering the mode.
8. The GPIO pull states for the Active and Low-Power states are hardware defaults. They can all be subsequently programmed as pull-ups or pull-downs.
9. Regarding GPIO pins, the following are the pull-up and pull-down values for both 3.3V and 1.8V VDDIO:

	Minimum (kΩ)	Typical (kΩ)	Maximum (kΩ)
3.3V VDDIO, Pull-downs:	51.5	44.5	38
3.3V VDDIO, Pull-ups:	37.4	39.5	44.5
1.8V VDDIO, Pull-downs:	64	83	116
1.8V VDDIO, Pull-ups:	65	86	118

Not Recommended for New Designs

Section 15: DC Characteristics



Note: Values in this data sheet are design goals and are subject to change based on the results of device characterization.

Absolute Maximum Ratings



Caution! The absolute maximum ratings in [Table 26](#) indicate levels where permanent damage to the device can occur, even if these limits are exceeded for only a brief duration. Functional operation is not guaranteed under these conditions. Operation at absolute maximum conditions for extended periods can adversely affect long-term reliability of the device.

Table 26: Absolute Maximum Ratings

Rating	Symbol	Value	Unit
DC supply for VBAT and PA driver supply:	VBAT	-0.5 to +6.0	V
DC supply voltage for digital I/O	VDDIO	-0.5 to 3.9	V
DC supply voltage for RF switch I/Os	VDDIO_RF	-0.5 to 3.9	V
DC input supply voltage for CLDO and LNLDO1	–	-0.5 to 1.575	V
DC supply voltage for RF analog	VDDRF	-0.5 to 1.32	V
DC supply voltage for core	VDDC	-0.5 to 1.32	V
WRF_TCXO_VDD	–	-0.5 to 3.63	V
Maximum undershoot voltage for I/O ^a	V _{undershoot}	-0.5	V
Maximum overshoot voltage for I/O ^a	V _{overshoot}	VDDIO + 0.5	V
Maximum Junction Temperature	T _j	125	°C

a. Duration not to exceed 25% of the duty cycle.

Not Recommended for New Designs

Environmental Ratings

The environmental ratings are shown in [Table 27](#).

Table 27: Environmental Ratings

Characteristic	Value	Units	Conditions/Comments
Ambient Temperature (T_A)	-30 to +85	°C	Functional operation ^a
Storage Temperature	-40 to +125	°C	–
Relative Humidity	Less than 60	%	Storage
	Less than 85	%	Operation

- a. Functionality is guaranteed but specifications require derating at extreme temperatures; see the specification tables for details.

Electrostatic Discharge Specifications

Extreme caution must be exercised to prevent electrostatic discharge (ESD) damage. Proper use of wrist and heel grounding straps to discharge static electricity is required when handling these devices. Always store unused material in its antistatic packaging.

Table 28: ESD Specifications

Pin Type	Symbol	Condition	ESD Rating		Unit
			WLCSP	WLBGA	
ESD, Handling Reference: NQY00083, Section 3.4, Group D9, Table B	ESD_HAND_HBM	Human body model contact discharge per JEDEC EID/JESD22-A114	±1.5 kV	±1 kV	V
CDM	ESD_HAND_CDM	Charged device model contact discharge per JEDEC EIA/JESD22-C101	±500V	±500V ^a	V

- a. Excludes WRF_RFOUT_2G pin, which is ±250V.

Recommended Operating Conditions and DC Characteristics



Caution! Functional operation is not guaranteed outside of the limits shown in [Table 29](#) and operation outside these limits for extended periods can adversely affect long-term reliability of the device.

Table 29: Recommended Operating Conditions and DC Characteristics

Parameter	Symbol	Value			Unit
		Minimum	Typical	Maximum	
DC supply voltage for VBAT	VBAT	2.3 ^a	–	4.8 ^b	V
DC supply voltage for core	VDD	1.14	1.2	1.26	V
DC supply voltage for RF blocks in chip	VDDRF	1.14	1.2	1.26	V
DC supply voltage for TCXO input buffer	WRF_TCXO_VDD	1.62	1.8	1.98	V
DC supply voltage for digital I/O	VDDIO, VDDIO_SD	1.71	–	3.63	V
DC supply voltage for RF switch I/Os	VDDIO_RF	3.13	3.3	3.46	V
External TSSI input	TSSI	0.15	–	0.95	V
Internal POR threshold	Vth_POR	0.4	–	0.7	V
SDIO Interface I/O Pins					
For VDDIO_SD = 1.8V:					
Input high voltage	VIH	1.27	–	–	V
Input low voltage	VIL	–	–	0.58	V
Output high voltage @ 2 mA	VOH	1.40	–	–	V
Output low voltage @ 2 mA	VOL	–	–	0.45	V
For VDDIO_SD = 3.3V:					
Input high voltage	VIH	0.625 × VDDIO_SD _SD	–	–	V
Input low voltage	VIL	–	–	0.25 × VDDIO_SD	V
Output high voltage @ 2 mA	VOH	0.75 × VDDIO_SD	–	–	V
Output low voltage @ 2 mA	VOL	–	–	0.125 × VDDIO_SD	V

Not Recommended for New Designs

Table 29: Recommended Operating Conditions and DC Characteristics (Cont.)

Parameter	Symbol	Value			Unit
		Minimum	Typical	Maximum	
Other Digital I/O Pins					
For VDDIO = 1.8V:					
Input high voltage	VIH	0.65 × VDDIO	–	–	V
Input low voltage	VIL	–	–	0.35 × VDDIO	V
Output high voltage @ 2 mA	VOH	VDDIO – 0.45	–	–	V
Output low voltage @ 2 mA	VOL	–	–	0.45	V
For VDDIO = 3.3V:					
Input high voltage	VIH	2.00	–	–	V
Input low voltage	VIL	–	–	0.80	V
Output high voltage @ 2 mA	VOH	VDDIO – 0.4	–	–	V
Output low voltage @ 2 mA	VOL	–	–	0.40	V
RF Switch Control Output Pins^c					
For VDDIO_RF = 3.3V:					
Output high voltage	VOH	VDDIO_RF – 0.4	–	–	V
Output low voltage	VOL	–	–	0.40	V
Load capacitance	C_load	–	–	5	pF

- The BCM4334 is functional across this range of voltages. Optimal RF performance specified in the data sheet, however, is guaranteed only for 3.0V < VBAT < 4.8V.
- The maximum continuous voltage is 4.8V. Voltages up to 5.5V for up to 10 seconds, cumulative duration, over the lifetime of the device are allowed. Voltages as high as 5.0V for up to 250 seconds, cumulative duration, over the lifetime of the device are allowed.
- Programmable 2 mA to 16 mA drive strength. Default is 10 mA.

Not Recommended for New Designs

Section 16: Bluetooth RF Specifications



Note: Values in this data sheet are design goals and are subject to change based on the results of device characterization.

Unless otherwise stated, limit values apply for the conditions specified in [Table 27: "Environmental Ratings,"](#) on page 117 and [Table 29: "Recommended Operating Conditions and DC Characteristics,"](#) on page 118. Typical values apply for the following conditions:

- VBAT = 3.6V
- Ambient temperature +25°C

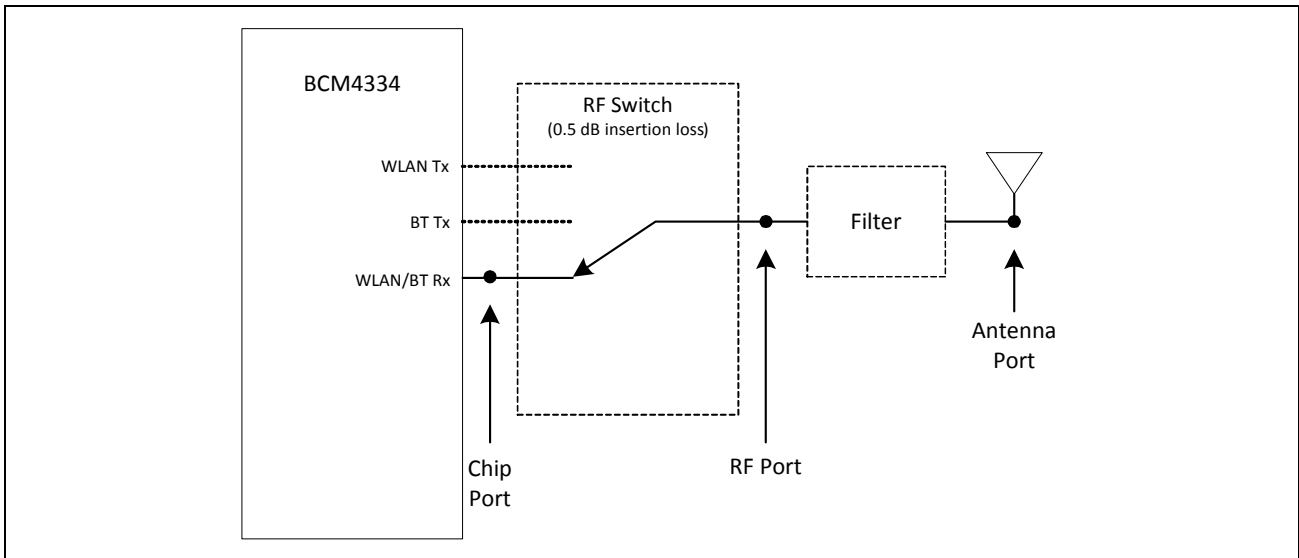

Figure 40: RF Port Location for Bluetooth Testing



Note: All Bluetooth specifications are measured at the Chip port unless otherwise specified.

Not Recommended for New Designs

Table 30: Bluetooth Receiver RF Specifications

Parameter	Conditions	Minimum	Typical	Maximum	Unit
Note: The specifications in this table are measured at the Chip port output unless otherwise specified.					
General					
Frequency range	–	2402	–	2480	MHz
RX sensitivity	GFSK, 0.1% BER, 1 Mbps	–	–93.5	–	dBm
	$\pi/4$ -DQPSK, 0.01% BER, 2 Mbps	–	–95.5	–	dBm
	8-DPSK, 0.01% BER, 3 Mbps	–	–89.5	–	dBm
Input IP3	–	–16	–	–	dBm
Maximum input at antenna	–	–	–	–20	dBm
Interference Performance^a					
C/I co-channel	GFSK, 0.1% BER	–	8	–	dB
C/I 1-MHz adjacent channel	GFSK, 0.1% BER	–	–7	–	dB
C/I 2-MHz adjacent channel	GFSK, 0.1% BER	–	–38	–	dB
C/I \geq 3-MHz adjacent channel	GFSK, 0.1% BER	–	–56	–	dB
C/I image channel	GFSK, 0.1% BER	–	–31	–	dB
C/I 1-MHz adjacent to image channel	GFSK, 0.1% BER	–	–46	–	dB
C/I co-channel	$\pi/4$ -DQPSK, 0.1% BER	–	9	–	dB
C/I 1-MHz adjacent channel	$\pi/4$ -DQPSK, 0.1% BER	–	–11	–	dB
C/I 2-MHz adjacent channel	$\pi/4$ -DQPSK, 0.1% BER	–	–39	–	dB
C/I \geq 3-MHz adjacent channel	$\pi/4$ -DQPSK, 0.1% BER	–	–55	–	dB
C/I image channel	$\pi/4$ -DQPSK, 0.1% BER	–	–23	–	dB
C/I 1-MHz adjacent to image channel	$\pi/4$ -DQPSK, 0.1% BER	–	–43	–	dB
C/I co-channel	8-DPSK, 0.1% BER	–	17	–	dB
C/I 1 MHz adjacent channel	8-DPSK, 0.1% BER	–	–4	–	dB
C/I 2 MHz adjacent channel	8-DPSK, 0.1% BER	–	–37	–	dB
C/I \geq 3-MHz adjacent channel	8-DPSK, 0.1% BER	–	–53	–	dB
C/I Image channel	8-DPSK, 0.1% BER	–	–16	–	dB
C/I 1-MHz adjacent to image channel	8-DPSK, 0.1% BER	–	–37	–	dB

Not Recommended for New Designs

Table 30: Bluetooth Receiver RF Specifications (Cont.)

Parameter	Conditions	Minimum	Typical	Maximum	Unit
Out-of-Band Blocking Performance (CW)					
30–2000 MHz	0.1% BER	–	–10.0	–	dBm
2000–2399 MHz	0.1% BER	–	–27	–	dBm
2498–3000 MHz	0.1% BER	–	–27	–	dBm
3000 MHz–12.75 GHz	0.1% BER	–	–10.0	–	dBm
Out-of-Band Blocking Performance, Modulated Interferer (LTE)					
GFSK (1 Mbps)^b					
2310MHz	LTE band40 TDD 20M BW	–	–23.8	–	dBm
2330MHz	LTE band40 TDD 20M BW	–	–24.2	–	dBm
2350MHz	LTE band40 TDD 20M BW	–	–25.7	–	dBm
2370MHz	LTE band40 TDD 20M BW	–	–28.4	–	dBm
2510MHz	LTE band7 FDD 20M BW	–	–26.6	–	dBm
2530MHz	LTE band7 FDD 20M BW	–	–22.8	–	dBm
2550MHz	LTE band7 FDD 20M BW	–	–22.3	–	dBm
2570MHz	LTE band7 FDD 20M BW	–	–21.4	–	dBm
$\pi/4$ DPSK (2 Mbps)^b					
2310MHz	LTE band40 TDD 20M BW	–	–22.2	–	dBm
2330MHz	LTE band40 TDD 20M BW	–	–24.5	–	dBm
2350MHz	LTE band40 TDD 20M BW	–	–25.4	–	dBm
2370MHz	LTE band40 TDD 20M BW	–	–27.5	–	dBm
2510MHz	LTE band7 FDD 20M BW	–	–25.3	–	dBm
2530MHz	LTE band7 FDD 20M BW	–	–24.7	–	dBm
2550MHz	LTE band7 FDD 20M BW	–	–21.9	–	dBm
2570MHz	LTE band7 FDD 20M BW	–	–21.1	–	dBm
8DPSK (3 Mbps)^b					
2310MHz	LTE band40 TDD 20M BW	–	–22.9	–	dBm
2330MHz	LTE band40 TDD 20M BW	–	–24.2	–	dBm
2350MHz	LTE band40 TDD 20M BW	–	–25.6	–	dBm
2370MHz	LTE band40 TDD 20M BW	–	–27.3	–	dBm
2510MHz	LTE band7 FDD 20M BW	–	–25.6	–	dBm
2530MHz	LTE band7 FDD 20M BW	–	–22.8	–	dBm
2550MHz	LTE band7 FDD 20M BW	–	–21.9	–	dBm
2570MHz	LTE band7 FDD 20M BW	–	–21.4	–	dBm

Not Recommended for New Designs

Table 30: Bluetooth Receiver RF Specifications (Cont.)

Parameter	Conditions	Minimum	Typical	Maximum	Unit
Out-of-Band Blocking Performance, Modulated Interferer (Non-LTE)					
GFSK (1 Mbps)^b					
698–716 MHz	WCDMA	–	–7.0	–	dBm
776–849 MHz	WCDMA	–	–7.6	–	dBm
824–849 MHz	GSM850	–	–7.9	–	dBm
824–849 MHz	WCDMA	–	–7.9	–	dBm
880–915 MHz	E-GSM	–	–7.8	–	dBm
880–915 MHz	WCDMA	–	–7.7	–	dBm
1710–1785 MHz	GSM1800	–	–12.7	–	dBm
1710–1785 MHz	WCDMA	–	–11.9	–	dBm
1850–1910 MHz	GSM1900	–	–12.5	–	dBm
1850–1910 MHz	WCDMA	–	–11.6	–	dBm
1880–1920 MHz	TD-SCDMA	–	–11.5	–	dBm
1920–1980 MHz	WCDMA	–	–11.3	–	dBm
2010–2025 MHz	TD-SCDMA	–	–13.8	–	dBm
2500–2570 MHz	WCDMA	–	–26.1	–	dBm
$\pi/4$ DPSK (2 Mbps)^b					
698–716 MHz	WCDMA	–	–6.9	–	dBm
776–794 MHz	WCDMA	–	–7.6	–	dBm
824–849 MHz	GSM850	–	–8.0	–	dBm
824–849 MHz	WCDMA	–	–7.9	–	dBm
880–915 MHz	E-GSM	–	–7.7	–	dBm
880–915 MHz	WCDMA	–	–7.8	–	dBm
1710–1785 MHz	GSM1800	–	–12.7	–	dBm
1710–1785 MHz	WCDMA	–	–11.9	–	dBm
1850–1910 MHz	GSM1900	–	–12.4	–	dBm
1850–1910 MHz	WCDMA	–	–11.6	–	dBm
1880–1920 MHz	TD-SCDMA	–	–12.0	–	dBm
1920–1980 MHz	WCDMA	–	–11.2	–	dBm
2010–2025 MHz	TD-SCDMA	–	–14.1	–	dBm
2500–2570 MHz	WCDMA	–	–25.1	–	dBm
8DPSK (3 Mbps)^b					
698–716 MHz	WCDMA	–	–8.1	–	dBm
776–794 MHz	WCDMA	–	–8.1	–	dBm
824–849 MHz	GSM850	–	–8.0	–	dBm
824–849 MHz	WCDMA	–	–8.0	–	dBm

Not Recommended for New Designs

Table 30: Bluetooth Receiver RF Specifications (Cont.)

Parameter	Conditions	Minimum	Typical	Maximum	Unit
880-915 MHz	E-GSM	–	–8.0	–	dBm
880-915 MHz	WCDMA	–	–7.9	–	dBm
1710-1785 MHz	GSM1800	–	–12.9	–	dBm
1710-1785 MHz	WCDMA	–	–11.4	–	dBm
1850-1910 MHz	GSM1900	–	–10.8	–	dBm
1850-1910 MHz	WCDMA	–	–9.7	–	dBm
1880-1920 MHz	TD-SCDMA	–	–11.0	–	dBm
1920-1980 MHz	WCDMA	–	–9.2	–	dBm
2010-2025 MHz	TD-SCDMA	–	–13.6	–	dBm
2500-2570 MHz	WCDMA	–	–25.2	–	dBm
Rx LO Leakage					
2.4 GHz band	–	–	–90.0	–80.0	dBm
Spurious Emissions					
30 MHz–1 GHz		–	–95	–62	dBm
1–12.75 GHz		–	–70	–47	dBm
869–894 MHz		–	–147	–	dBm/Hz
925–960 MHz		–	–147	–	dBm/Hz
1805–1880 MHz		–	–147	–	dBm/Hz
1930–1990 MHz		–	–147	–	dBm/Hz
2110–2170 MHz		–	–147	–	dBm/Hz

- a. The maximum value represents the actual Bluetooth specification required for Bluetooth qualification as defined in the version 4.0 specification.
- b. Bluetooth reference level is taken at the 3dB Rx desense on each of the modulation schemes.

Not Recommended for New Designs

Table 31: Bluetooth Transmitter RF Specifications^a

Parameter	Conditions	Minimum	Typical	Maximum	Unit
General					
Frequency range		2402	–	2480	MHz
Basic rate (GFSK) Tx power at Bluetooth		11.0	13.0	–	dBm
QPSK Tx Power at Bluetooth		8.0	10.0	–	dBm
8PSK Tx Power at Bluetooth		8.0	10.0	–	dBm
Power control step		2	4	6	dB
GFSK In-Band Spurious Emissions					
–20 dBc BW	–	–	.93	1	MHz
EDR In-Band Spurious Emissions					
1.0 MHz < M – N < 1.5 MHz	M – N = the frequency range for which the spurious emission is measured relative to the transmit center frequency.	–	–38	–26.0	dBc
1.5 MHz < M – N < 2.5 MHz		–	–31	–20.0	dBm
M – N ≥ 2.5 MHz ^b		–	–43	–40.0	dBm
Out-of-Band Spurious Emissions					
30 MHz to 1 GHz	–	–	–	–36.0 ^{c, d}	dBm
1 GHz to 12.75 GHz	–	–	–	–30.0 ^{d, e, f}	dBm
1.8 GHz to 1.9 GHz	–	–	–	–47.0	dBm
5.15 GHz to 5.3 GHz	–	–	–	–47.0	dBm
GPS Band Spurious Emissions					
Spurious emissions	–	–	–103	–	dBm
Out-of-Band Noise Floor^g					
65–108 MHz	FM Rx	–	–147	–	dBm/Hz
776–794 MHz	CDMA2000	–	–147	–	dBm/Hz
869–960 MHz	cdmaOne, GSM850	–	–147	–	dBm/Hz
925–960 MHz	E-GSM	–	–147	–	dBm/Hz
1570–1580 MHz	GPS	–	–146	–	dBm/Hz
1805–1880 MHz	GSM1800	–	–145	–	dBm/Hz
1930–1990 MHz	GSM1900, cdmaOne, WCDMA	–	–144	–	dBm/Hz
2110–2170 MHz	WCDMA	–	–141	–	dBm/Hz

- Unless otherwise specified, the specifications in this table are measured at the chip output port and output power specifications are with the temperature correction algorithm and TSSI enabled.
- Typically measured at an offset of ±3 MHz.
- The maximum value represents the value required for Bluetooth qualification as defined in the v4.0 specification.
- The spurious emissions during Idle mode are the same as specified in [Table 31 on page 125](#).
- Specified at the Bluetooth Antenna port.
- Meets this specification using a front-end band-pass filter.
- Transmitted power in cellular and FM bands at the Bluetooth Antenna port. See [Figure 40 on page 120](#) for location of the port.

Table 32: Local Oscillator Performance

Parameter	Minimum	Typical	Maximum	Unit
LO Performance				
Lock time	–	72	–	μs
Initial carrier frequency tolerance	–	±25	±75	kHz
Frequency Drift				
DH1 packet	–	±8	±25	kHz
DH3 packet	–	±8	±40	kHz
DH5 packet	–	±8	±40	kHz
Drift rate	–	5	20	kHz/50 μs
Frequency Deviation				
00001111 sequence in payload ^a	140	155	175	kHz
10101010 sequence in payload ^b	115	140	–	kHz
Channel spacing	–	1	–	MHz

a. This pattern represents an average deviation in payload.

b. Pattern represents the maximum deviation in payload for 99.9% of all frequency deviations.

Table 33: BLE RF Specifications

Parameter	Conditions	Minimum	Typical	Maximum	Unit
Frequency range	–	2402		2480	MHz
Rx sense ^a	GFSK, 0.1% BER, 1 Mbps	–	–95.5	–	dBm
Tx power ^b	–	–	8.5	–	dBm
Mod Char: delta f1 average	–	225	255	275	kHz
Mod Char: delta f2 max ^c	–	99.9	–	–	%
Mod Char: ratio	–	0.8	0.95	–	%

a. The Bluetooth tester is set so that Dirty Tx is on.

b. BLE Tx power can be increased to compensate for front-end losses such as BPF, diplexer, switch, and so forth). The output is capped at 12 dBm out. The BLE Tx power at the antenna port cannot exceed the 10 dBm specification limit.

c. At least 99.9% of all delta F2 max frequency values recorded over 10 packets must be greater than 185 kHz.

Section 17: FM Receiver Specifications



Note: Values in this data sheet are design goals and are subject to change based on the results of device characterization.

Unless otherwise stated, limit values apply for the conditions specified in [Table 27: “Environmental Ratings,”](#) on page 117 and [Table 29: “Recommended Operating Conditions and DC Characteristics,”](#) on page 118. Typical values apply for the following conditions:

- VBAT = 3.6V
- Ambient temperature +25°C

Table 34: FM Receiver Specifications

Parameter	Conditions ^a	Minimum	Typical	Maximum	Units
RF Parameters					
Operating frequency ^b	Frequencies inclusive	65	–	108	MHz
Sensitivity ^c	FM only, SNR ≥ 26 dB	–	–0.5	–	dBμV EMF
		–	0.95	–	μV EMF
		–	–6.5	–	dBμV
Receiver adjacent channel selectivity ^{c, d}	Measured for 30 dB SNR at audio output with best tune. Signal of interest: 23 dBμV EMF (14.1 μV EMF)	–	51	–	dB
		–	62	–	dB
		–	–	–	–
Intermediate (S + N)/N ^c	Vin = 20 dBμV (10 μV EMF)	45	53	–	dB
Intermodulation performance ^{c, d}	Blocker level increased until SNR = 30 dB. Modulated interferer: At $f_{\text{signal_of_interest}} \pm 400$ kHz and ± 4 MHz, $\Delta f = 22.5$ kHz, $f_{\text{mod}} = 1$ kHz. CW interferer: At $f_{\text{signal_of_interest}} \pm 800$ kHz and ± 8 MHz.	–	55	–	dBc
		–	–	–	–
AM suppression, mono ^c	Vin = 23 dBμV EMF (14.1 μV EMF). AM at 400 Hz with $m = 0.3$. No A-weighted or any other filtering applied.	40	–	–	dB

Not Recommended for New Designs

Table 34: FM Receiver Specifications (Cont.)

Parameter	Conditions ^a	Minimum	Typical	Maximum	Units
RDS					
RDS sensitivity ^{e, f}	RDS deviation = 1.2 kHz	–	16	–	dB μ V EMF
		–	6.3	–	μ V EMF
		–	10	–	dB μ V
	RDS deviation = 2 kHz	–	12	–	dB μ V EMF
		–	4	–	μ V EMF
		–	6	–	dB μ V
RDS selectivity ^f	Wanted Signal: 33 dB μ V EMF (45 μ V EMF), 2 kHz RDS deviation, Δf = 32 kHz, f_{mod} = 1 kHz, Δf Pilot = 7.5 kHz, with best tune Interferer: Δf = 40 kHz, f_{mod} = 1 kHz				
	± 200 kHz	–	49	–	dB
	± 300 kHz	–	52	–	dB
	± 400 kHz	–	52	–	dB
RF Input					
RF input impedance	–	1.5	–	–	k Ω
Antenna tuning cap	–	2.5	–	30	pF
Maximum input level ^c	SNR > 26 dB	–	–	113	dB μ V EMF
		–	–	446	mV EMF
		–	–	107	dB μ V
RF conducted emissions	Local oscillator breakthrough measured on the reference port	–	–	–55	dBm
	869–894 MHz, 925–960 MHz, 1805–1880 MHz, and 1930–1990 MHz. GPS.	–	–	–90	dBm

Not Recommended for New Designs

Table 34: FM Receiver Specifications (Cont.)

Parameter	Conditions^a	Minimum	Typical	Maximum	Units
RF blocking levels at the FM antenna input with a 40 dB SNR (assumes a 50Ω input and excludes spurs)	GSM850, E-GSM (std), BW = 0.2 MHz, 824–849 MHz, 880–915 MHz.	–	7	–	dBm
	GSM850, E-GSM (edge), BW = 0.2 MHz, 824–849 MHz, 880–915 MHz.	–	0	–	dBm
	GSM DCS 1800, PCS 1900 (std, edge), BW = 0.2 MHz, 1710–1785 MHz, 1850–1910 MHz.	–	12	–	dBm
	WCDMA: II(I), III(IV,X), BW = 5 MHz, 1850–1980 MHz (1920–1980 MHz), 1710–1785 MHz (1710–1755 MHz, 1710–1770 MHz)	–	12	–	dBm
	WCDMA: V(VI), VIII, XII, XIII, XIV, BW = 5 MHz, 824–849 MHz (830–840 MHz), 880–915 MHz.	–	5	–	dBm
	CDMA2000, CDMA One, BW = 1.25 MHz, 824–849 MHz, 887–925 MHz, 776–794 MHz.	–	0	–	dBm
	CDMA2000, CDMA One, BW= 1.25 MHz, 1850–1910 MHz, 1750–1780 MHz, 1920–1980 MHz.	–	12	–	dBm
	Bluetooth, BW = 1 MHz, 2402–2480 MHz.	–	11	–	dBm
	IEEE 802.11g/b, BW = 20 MHz, 2400–2483.5 MHz.	–	11	–	dBm
	IEEE 802.11a, BW = 20 MHz, 4915–5825 MHz.	–	6	–	dBm
Tuning					
Frequency step	–	10	–	–	kHz
Settling time	Single frequency switch in any direction to a frequency within the 88–108 MHz or 76–90 MHz bands. Time measured to within 5 kHz of the final frequency.	–	150	–	μs
Search time	Total time for an automatic search to sweep from 88–108 MHz or 76–90 MHz (or in the reverse direction) assuming no channels are found.	–	–	8	sec

Not Recommended for New Designs

Table 34: FM Receiver Specifications (Cont.)

Parameter	Conditions ^a	Minimum	Typical	Maximum	Units
General Audio					
Audio output level ^g	–	–14.5	–	–12.5	dBFS
Maximum audio output level ^h	–	–	–	0	dBFS
Soft mute attenuation and start level	Muting is performed dynamically, proportional to the desired FM input signal C/N. The muting characteristic is fully programmable. See “Audio Features” on page 65.				
Maximum (S+N)/N, mono ⁱ	–	–	69	–	dB
Maximum (S+N)/N, stereo ^g	–	–	64	–	dB
Total harmonic distortion, mono	Vin = 66 dBμV EMF(2 mV EMF):				
	Δf = 75 kHz, fmod = 400 Hz.				
	–	–	–	0.8	%
	Δf = 75 kHz, fmod = 1 kHz.				
–	–	–	0.8	%	
Δf = 75 kHz, fmod = 3 kHz.					
–	–	–	0.8	%	
Δf = 100 kHz, fmod = 1 kHz.					
–	–	–	1.0	%	
Total harmonic distortion, stereo	Vin = 66 dBμV EMF (2 mV EMF), Δf = 67.5 kHz, fmod = 1 kHz, Δf pilot = 7.5 kHz, L = R				
–	–	–	–	1.5	%
Audio spurious products ⁱ	Range from 300 Hz to 15 kHz with respect to a 1 kHz tone.				
–	–	–	–	–60	dBc
Audio bandwidth	Vin = 66 dBμV EMF(2 mV EMF), Δf = 8 kHz, for 50 μs:				
	Upper –3 dB point.				
	15	–	–	–	kHz
Lower –3 dB point.					
–	–	–	–	20	Hz
Audio in-band ripple	100 Hz to 13 kHz, Vin = 66 dBμV EMF (2 mV EMF), Δf = 8 kHz, for 50 μs.				
–0.5	–	–	–	0.5	dB
Deemphasis time constant tolerance	With respect to 50 and 75 μs.				
–	–	–	–	±5	%
RSSI range	With 1 dB resolution and ±5 dB accuracy at room temperature.				
	3	–	–	83	dBμV EMF
	1.41	–	–	1.41E+4	μV EMF
–3	–	–	77	dBμV	
Stereo Decoder					
Stereo channel separation	Forced Stereo mode				
	Vin = 66 dBμV EMF (2 mV EMF), Δf = 67.5 kHz, fmod = 1 kHz, Δf Pilot = 6.75 kHz, R = 0, L = 1				
–	–	–	48	–	dB

Not Recommended for New Designs

Table 34: FM Receiver Specifications (Cont.)

Parameter	Conditions^a	Minimum	Typical	Maximum	Units
Mono stereo blend and switching	Dynamically proportional to the desired FM input signal C/N. The blending and switching characteristics are fully programmable. See “Audio Features” on page 65.				
Pilot suppression	$V_{in} = 66 \text{ dB}\mu\text{V EMF (2 mV EMF)}$, $\Delta f = 75 \text{ kHz}$, $f_{mod} = 1 \text{ kHz}$.	46	–	–	dB
Pause Detection					
Audio level at which a pause is detected	Relative to 1-kHz tone, $\Delta f = 22.5 \text{ kHz}$. 4 values in 3 dB steps	–	–	–	–
Audio pause duration	4 values	20	–	40	ms

- The following conditions are applied to all relevant tests unless otherwise indicated: Preemphasis and deemphasis of 50 μs , R = L for mono, BAF = 300 Hz to 15 kHz, A-weighted filtering applied.
- Contact your Broadcom representative for applications operating between 65–76 MHz.
- Signal of interest: $\Delta f = 22.5 \text{ kHz}$, $f_{mod} = 1 \text{ kHz}$.
- Interferer: $\Delta f = 22.5 \text{ kHz}$, $f_{mod} = 1 \text{ kHz}$.
- RDS sensitivity numbers are for 87.5–108 MHz only.
- $V_{in} = \Delta f = 32 \text{ kHz}$, $f_{mod} = 1 \text{ kHz}$, $\Delta f_{pilot} = 7.5 \text{ kHz}$, and with an interferer for 95% of blocks decoded with no errors after correction.
- $V_{in} = 66 \text{ dB}\mu\text{V EMF (2 mV EMF)}$, $\Delta f = 22.5 \text{ kHz}$, $f_{mod} = 1 \text{ kHz}$, $\Delta f_{pilot} = 6.75 \text{ kHz}$.
- $V_{in} = 66 \text{ dB}\mu\text{V EMF (2 mV EMF)}$, $\Delta f = 100 \text{ kHz}$, $f_{mod} = 1 \text{ kHz}$, $\Delta f_{pilot} = 6.75 \text{ kHz}$.
- $V_{in} = 66 \text{ dB}\mu\text{V EMF (2 mV EMF)}$, $\Delta f = 22.5 \text{ kHz}$, $f_{mod} = 1 \text{ kHz}$.

Not Recommended for New Designs

Section 18: WLAN RF Specifications

Introduction

The BCM4334 includes an integrated dual-band direct conversion radio that supports either the 2.4 GHz band or the 5 GHz band. The BCM4334 does not provide simultaneous 2.4 GHz and 5 GHz operation. This section describes the RF characteristics of the 2.4 GHz and 5 GHz portions of the radio.

Note: Values in this data sheet are design goals and are subject to change based on the results of device characterization.

Unless otherwise stated, limit values apply for the conditions specified in [Table 27: “Environmental Ratings,” on page 117](#) and [Table 29: “Recommended Operating Conditions and DC Characteristics,” on page 118](#). Typical values apply for the following conditions:

- VBAT = 3.6V
- Ambient temperature +25°C

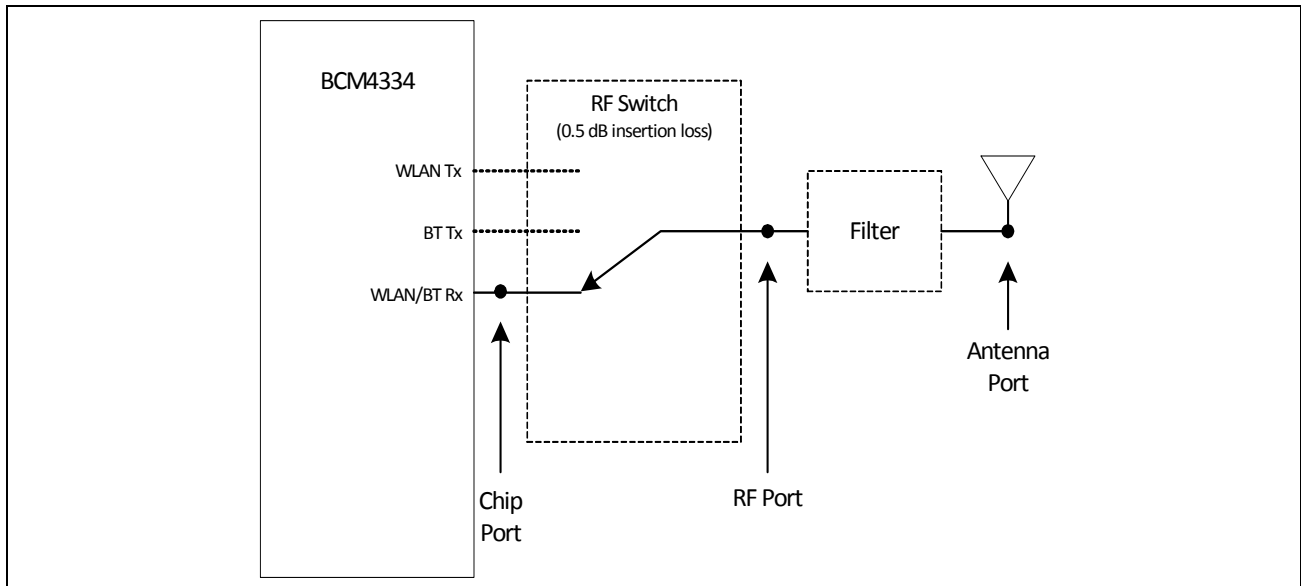

Figure 41: Port Locations

Note: All WLAN specifications are measured at the chip port, unless otherwise specified.

Not Recommended for New Designs

2.4 GHz Band General RF Specifications

Table 35: 2.4 GHz Band General RF Specifications

<i>Item</i>	<i>Condition</i>	<i>Minimum</i>	<i>Typical</i>	<i>Maximum</i>	<i>Unit</i>
Tx/Rx switch time	Including TX ramp down	–	–	5	μs
Rx/Tx switch time	Including TX ramp up	–	–	2	μs
Power-up and power-down ramp time	DSSS/CCK modulations	–	–	< 2	μs

Not Recommended for New Designs

WLAN 2.4 GHz Receiver Performance Specifications



Note: The specifications in [Table 36](#) are measured at the chip port, unless otherwise specified.

Table 36: WLAN 2.4 GHz Receiver Performance Specifications

Parameter	Condition/Notes	Minimum	Typical	Maximum	Unit
Frequency range	–	2400	–	2500	MHz
RX sensitivity (8% PER for 1024 octet PSDU) ^a	1 Mbps DSSS	–	–98.9	–	dBm
	2 Mbps DSSS	–	–97.9	–	dBm
	5.5 Mbps DSSS	–	–93.5	–	dBm
	11 Mbps DSSS	–	–91.7	–	dBm
RX sensitivity (10% PER for 1024 octet PSDU) ^a	6 Mbps OFDM	–	–93.7	–	dBm
	9 Mbps OFDM	–	–92.4	–	dBm
	12 Mbps OFDM	–	–90	–	dBm
	18 Mbps OFDM	–	–88.4	–	dBm
	24 Mbps OFDM	–	–85.4	–	dBm
	36 Mbps OFDM	–	–82.7	–	dBm
	48 Mbps OFDM	–	–79.3	–	dBm
	54 Mbps OFDM	–	–78.1	–	dBm
RX sensitivity (10% PER for 4096 octet PSDU) ^{a,b} . Defined for default parameters: GF, 800 ns GI, and non-STBC.	20 MHz channel spacing for all MCS rates (GF)				
	MCS0	–	–93.6	–	dBm
	MCS 1	–	–90.6	–	dBm
	MCS 2	–	–88.3	–	dBm
	MCS 3	–	–85.7	–	dBm
	MCS 4	–	–83	–	dBm
	MCS 5	–	–79.4	–	dBm
	MCS 6	–	–77.9	–	dBm
	MCS 7	–	–76	–	dBm
RX sensitivity (10% PER for 4096 octet PSDU) ^{a,b} . Defined for default parameters: GF, 800 ns GI, and non-STBC.	40 MHz channel spacing for all MCS rates (GF)				
	MCS 0	–	–92	–	dBm
	MCS 1	–	–88.5	–	dBm
	MCS 2	–	–86.5	–	dBm
	MCS 3	–	–84	–	dBm
	MCS 4	–	–81	–	dBm
	MCS 5	–	–76	–	dBm
	MCS 6	–	–74.5	–	dBm
	MCS 7	–	–73	–	dBm

Not Recommended for New Designs

Table 36: WLAN 2.4 GHz Receiver Performance Specifications (Cont.)

Parameter	Condition/Notes	Minimum	Typical	Maximum	Unit	
RX sensitivity (10% PER for 4096 octet PSDU) ^{a,c} . Defined for default parameters: Mixed mode, 800 ns GI, and non-STBC.	20 MHz channel spacing for all MCS rates (Mixed mode)					
	MCS0	–	–93.0	–	dBm	
	MCS 1	–	–89.9	–	dBm	
	MCS 2	–	–87.5	–	dBm	
	MCS 3	–	–84.8	–	dBm	
	MCS 4	–	–81.9	–	dBm	
	MCS 5	–	–78.2	–	dBm	
	MCS 6	–	–76.6	–	dBm	
RX sensitivity (10% PER for 4096 octet PSDU) ^{a,b} . Defined for default parameters: Mixed mode, 800 ns GI, and non-STBC.	40 MHz channel spacing for all MCS rates (Mixed mode)					
	MCS 0	–	–91.0	–	dBm	
	MCS 1	–	–87.4	–	dBm	
	MCS 2	–	–85.2	–	dBm	
	MCS 3	–	–82.6	–	dBm	
	MCS 4	–	–79.4	–	dBm	
	MCS 5	–	–74.3	–	dBm	
	MCS 6	–	–72.6	–	dBm	
Blocking level for 1dB Rx sensitivity degradation (without external filtering) ^d	776–794 MHz	CDMA2000	–20	–	–	dBm
	824–849 MHz ^e	cdmaOne	–24.5	–	–	dBm
	824–849 MHz	GSM850	–20	–	–	dBm
	880–915 MHz	E-GSM	–18	–	–	dBm
	1710–1785 MHz	GSM1800	–20	–	–	dBm
	1850–1910 MHz	GSM1800	–22	–	–	dBm
	1850–1910 MHz	cdmaOne	–32	–	–	dBm
	1850–1910 MHz	WCDMA	–29	–	–	dBm
1920–1980 MHz	WCDMA	–32	–	–	dBm	
In-band static CW jammer immunity ($f_c - 8 \text{ MHz} < f_{cw} < + 8 \text{ MHz}$)	Rx PER < 1%, 54 Mbps OFDM, 1000 octet PSDU for: (RxSens + 23 dB < Rxlevel < max input level)	–80	–	–	dBm	
Input In-Band IP3 ^a	Maximum LNA gain	–	–15.5	–	dBm	
	Minimum LNA gain	–	–1.5	–	dBm	
Maximum Receive Level @ 2.4 GHz	@ 1, 2 Mbps (8% PER, 1024 octets)	–3.5	–	–	dBm	
	@ 5.5, 11 Mbps (8% PER, 1024 octets)	–9.5	–	–	dBm	
	@ 6–54 Mbps (10% PER, 1024 octets)	–19.5	–	–	dBm	
	@ MCS0–7 rates (10% PER, 4095 octets)	–19.5	–	–	dBm	
LPF 3 dB Bandwidth	–	9	–	10	MHz	

Not Recommended for New Designs

Table 36: WLAN 2.4 GHz Receiver Performance Specifications (Cont.)

Parameter	Condition/Notes	Minimum	Typical	Maximum	Unit	
Adjacent channel rejection-DSSS (Difference between interfering and desired signal at 8% PER for 1024 octet PSDU with desired signal level as specified in Condition/Notes)	Desired and interfering signal 30 MHz apart					
	1 Mbps DSSS	-74 dBm	35	-	-	dB
	2 Mbps DSSS	-74 dBm	35	-	-	dB
	Desired and interfering signal 25 MHz apart					
	5.5 Mbps DSSS	-70 dBm	35	-	-	dB
	11 Mbps DSSS	-70 dBm	35	-	-	dB
Adjacent channel rejection-OFDM (Difference between interfering and desired signal (25 MHz apart) at 10% PER for 1024 octet PSDU with desired signal level as specified in Condition/Notes)	6 Mbps OFDM	-79 dBm	16	-	-	dB
	9 Mbps OFDM	-78 dBm	15	-	-	dB
	12 Mbps OFDM	-76 dBm	13	-	-	dB
	18 Mbps OFDM	-74 dBm	11	-	-	dB
	24 Mbps OFDM	-71 dBm	8	-	-	dB
	36 Mbps OFDM	-67 dBm	4	-	-	dB
	48 Mbps OFDM	-63 dBm	0	-	-	dB
	54 Mbps OFDM	-62 dBm	-1	-	-	dB
Adjacent channel rejection MCS0-7 (Difference between interfering and desired signal (25 MHz apart) at 10% PER for 4096 octet PSDU with desired signal level as specified in Condition/Notes)	MCS7	-61 dBm	-2	-	-	dB
	MCS6	-62 dBm	-1	-	-	dB
	MCS5	-63 dBm	0	-	-	dB
	MCS4	-67 dBm	4	-	-	dB
	MCS3	-71 dBm	8	-	-	dB
	MCS2	-74 dBm	11	-	-	dB
	MCS1	-76 dBm	13	-	-	dB
	MCS0	-79 dBm	16	-	-	dB
Maximum receiver gain	-	-	-	105	-	dB
Gain control step	-	-	-	3	-	dB
RSSI accuracy ^f	Range -98 dBm to -30 dBm	-5	-	5	-	dB
	Range above -30 dBm	-8	-	8	-	dB
Return loss	Z ₀ = 50Ω, across the dynamic range	6	10	-	-	dB
Receiver cascaded NF	At maximum gain	-	3.5	-	-	

- Derate by 1.5 dB for -30 °C to -10°C and 55°C to 85°C.
- Sensitivity degradations for alternate settings in MCS modes. MM: 0.5 dB drop, SGI: 2 dB drop, and STBC: 0.75 dB drop.
- Sensitivity degradations for alternate settings in MCS modes. MM: 0.5 dB drop, SGI: 2 dB drop, and STBC: 0.75 dB drop.
- The cellular standard listed for each band indicates the type of modulation used to generate the interfering signal in that band for the purpose of this test. It is not intended to indicate any specific usage of each band in any specific country.
- The blocking levels are valid for channels 1 to 11. (For higher channels, the performance may be lower due to third harmonic signals (3 × 824 MHz) falling within band.)
- The minimum and maximum values shown have a 95% confidence level.

Not Recommended for New Designs

WLAN 2.4 GHz Transmitter Performance Specifications



Note: The specifications in [Table 37](#) are measured at the chip port output, unless otherwise specified.

Table 37: WLAN 2.4 GHz Transmitter Performance Specifications

Parameter	Condition/Notes		Minimum	Typical	Maximum	Unit
Frequency range	–		2400	–	2500	MHz
Transmitted power in cellular and FM bands (at –5 dBm, 90% duty cycle, OFDM) ^a	76–108 MHz	FM Rx	–	–171	–	dBm/Hz
	776–794 MHz	–	–	–171	–	dBm/Hz
	869–960 MHz	cdmaOne, GSM850	–	–171	–	dBm/Hz
	925–960 MHz	E-GSM	–	–171	–	dBm/Hz
	1570–1580 MHz	GPS	–	–170	–	dBm/Hz
	1805–1880 MHz	GSM, WCDMA, LTE	–	–163	–	dBm/Hz
	1930–1990 MHz	GSM, WCDMA, LTE	–	–161	–	dBm/Hz
Harmonic level (–5 dBm output power; 100% duty cycle)	4.8–5.0 GHz	2nd harmonic	–	–41	–	dBm/1 MHz
	7.2–7.5 GHz	3rd harmonic	–	–69.5	–	dBm/1 MHz
OFDM EVM ^b	OFDM, BPSK	0 dBm	–29	–31	–	dB
OFDM EVM ^b	OFDM, 64 QAM	–3 dBm	–31.9	–33.9	–	dB
OFDM EVM ^b	MCS7	–6 dBm	–33	–35	–	dB
Phase noise	37.4 MHz Crystal, Integrated from 10 kHz to 10 MHz		–	0.5	–	Degrees
Tx power control dynamic range	–		20	–	–	dB
Carrier suppression	–		15	–	–	dBc
Gain control step	–		–	0.25	–	dB
Return loss at Chip port Tx $Z_0 = 50\Omega$	–		4	6	–	dB

- The cellular standards listed indicate only typical usages of that band in some countries. Other standards may also be used within those bands.
- Derate power by 2 dB for temperatures less than –10C° or more than +55C°.

Not Recommended for New Designs

WLAN 5 GHz Receiver Performance Specifications



Note: The specifications in [Table 38](#) are measured at the chip port input, unless otherwise specified.

Table 38: WLAN 5 GHz Receiver Performance Specifications

<i>Parameter</i>	<i>Condition/Notes</i>	<i>Minimum</i>	<i>Typical</i>	<i>Maximum</i>	<i>Unit</i>
Frequency range	–	4900	–	5845	MHz
RX sensitivity (10% PER for 1000 octet PSDU) ^a	6 Mbps OFDM	–	–92.2	–	dBm
	9 Mbps OFDM	–	–90.9	–	dBm
	12 Mbps OFDM	–	–88.5	–	dBm
	18 Mbps OFDM	–	–86.9	–	dBm
	24 Mbps OFDM	–	–83.9	–	dBm
	36 Mbps OFDM	–	–81.2	–	dBm
	48 Mbps OFDM	–	–77.8	–	dBm
	54 Mbps OFDM	–	–76.6	–	dBm
RX sensitivity (10% PER for 4096 octet PSDU) ^a Defined for default parameters: GF, 800 ns GI, and non-STBC.	20 MHz channel spacing for all MCS rates (GF)				
	MCS 0	–	–92.1	–	dBm
	MCS 1	–	–89.1	–	dBm
	MCS 2	–	–86.8	–	dBm
	MCS 3	–	–84.2	–	dBm
	MCS 4	–	–81.5	–	dBm
	MCS 5	–	–77.9	–	dBm
	MCS 6	–	–76.4	–	dBm
	MCS 7	–	–74.5	–	dBm
RX sensitivity (10% PER for 4096 octet PSDU) ^a Defined for default parameters: GF, 800 ns GI, and non-STBC.	40 MHz channel spacing for all MCS rates (GF)				
	MCS 0	–	–89.8	–	dBm
	MCS 1	–	–87	–	dBm
	MCS 2	–	–85	–	dBm
	MCS 3	–	–82.5	–	dBm
	MCS 4	–	–79.5	–	dBm
	MCS 5	–	–74.5	–	dBm
	MCS 6	–	–73	–	dBm
	MCS 7	–	–71.5	–	dBm

Not Recommended for New Designs

Table 38: WLAN 5 GHz Receiver Performance Specifications (Cont.)

Parameter	Condition/Notes		Minimum	Typical	Maximum	Unit
RX sensitivity (10% PER for 4096 octet PSDU) ^a Defined for default parameters: Mixed mode, 800 ns GI, and non-STBC.	20 MHz channel spacing for all MCS rates (Mixed mode)					
	MCS 0		–	–91.5	–	dBm
	MCS 1		–	–88.4	–	dBm
	MCS 2		–	–86.0	–	dBm
	MCS 3		–	–83.3	–	dBm
	MCS 4		–	–80.4	–	dBm
	MCS 5		–	–76.7	–	dBm
	MCS 6		–	–75.1	–	dBm
RX sensitivity (10% PER for 4096 octet PSDU) ^a Defined for default parameters: Mixed mode, 800 ns GI, and non-STBC.	40 MHz channel spacing for all MCS rates (Mixed mode)					
	MCS 0		–	–89.5	–	dBm
	MCS 1		–	–85.9	–	dBm
	MCS 2		–	–83.7	–	dBm
	MCS 3		–	–81.1	–	dBm
	MCS 4		–	–77.9	–	dBm
	MCS 5		–	–72.8	–	dBm
	MCS 6		–	–71.1	–	dBm
Blocking level for 1 dB Rx sensitivity degradation (without external filtering) ^b	776–794 MHz	CDMA2000	–21	–	–	dBm
	824–849 MHz	cdmaOne	–20	–	–	dBm
	824–849 MHz	GSM850	–12	–	–	dBm
	880–915 MHz	E-GSM	–12	–	–	dBm
	1710–1785 MHz	GSM1800	–15	–	–	dBm
	1850–1910 MHz	GSM1800	–15	–	–	dBm
	1850–1910 MHz	cdmaOne	–20	–	–	dBm
	1850–1910 MHz	WCDMA	–24	–	–	dBm
Input In-Band IP3 ^a	Maximum LNA gain		–	–15.5	–	dBm
	Minimum LNA gain		–	–1.5	–	dBm
Maximum receive level @ 5.24 GHz	@ 6, 9, 12 Mbps		–29.5	–	–	dBm
	@ 18, 24, 36, 48, 54 Mbps		–29.5	–	–	dBm
LPF 3 dB bandwidth	–		9	–	18	MHz

Not Recommended for New Designs

Table 38: WLAN 5 GHz Receiver Performance Specifications (Cont.)

Parameter	Condition/Notes	Minimum	Typical	Maximum	Unit	
Adjacent channel rejection (Difference between interfering and desired signal (20 MHz apart) at 10% PER for 1000 octet PSDU with desired signal level as specified in Condition/Notes)	6 Mbps OFDM	-79 dBm	16	-	-	dB
	9 Mbps OFDM	-78 dBm	15	-	-	dB
	12 Mbps OFDM	-76 dBm	13	-	-	dB
	18 Mbps OFDM	-74 dBm	11	-	-	dB
	24 Mbps OFDM	-71 dBm	8	-	-	dB
	36 Mbps OFDM	-67 dBm	4	-	-	dB
	48 Mbps OFDM	-63 dBm	0	-	-	dB
	54 Mbps OFDM	-62 dBm	-1	-	-	dB
	65 Mbps OFDM	-61 dBm	-2	-	-	dB
Alternate adjacent channel rejection (Difference between interfering and desired signal (40 MHz apart) at 10% PER for 1000 ^c octet PSDU with desired signal level as specified in Condition/Notes)	6 Mbps OFDM	-78.5 dBm	32	-	-	dB
	9 Mbps OFDM	-77.5 dBm	31	-	-	dB
	12 Mbps OFDM	-75.5 dBm	29	-	-	dB
	18 Mbps OFDM	-73.5 dBm	27	-	-	dB
	24 Mbps OFDM	-70.5 dBm	24	-	-	dB
	36 Mbps OFDM	-66.5 dBm	20	-	-	dB
	48 Mbps OFDM	-62.5 dBm	16	-	-	dB
	54 Mbps OFDM	-61.5 dBm	15	-	-	dB
65 Mbps OFDM	-60.5 dBm	14	-	-	dB	
Maximum receiver gain	-	-	100	-	dB	
Gain control step	-	-	3	-	dB	
RSSI accuracy ^d	Range -98 dBm to -30 dBm	-5	-	5	dB	
	Range above -30 dBm	-8	-	8	dB	
Return loss	Z ₀ = 50Ω	6	10	-	dB	
Receiver cascaded noise figure	At maximum gain	-	5.0	-	dB	

- Derate by 1.5 dB for -30 °C to -10°C and 55°C to 85°C.
- The cellular standard listed for each band indicates the type of modulation used to generate the interfering signal in that band for the purpose of this test. It is not intended to indicate any specific usage of each band in any specific country.
- For 65 Mbps, the size is 4096.
- The minimum and maximum values shown have a 95% confidence level.

Not Recommended for New Designs

WLAN 5 GHz Transmitter Performance Specifications



Note: The specifications in [Table 39](#) are measured at the chip port, unless otherwise specified.

Table 39: WLAN 5 GHz Transmitter Performance Specifications

Parameter	Condition/Notes		Minimum	Typical	Maximum	Unit
Frequency range	–		4900	–	5845	MHz
Transmitted power in cellular and FM bands (at –5 dBm, >90% duty cycle, OFDM) ^a	76–108 MHz	FM Rx	–	–171	–	dBm/Hz
	776–794 MHz	–	–	–171	–	dBm/Hz
	869–960 MHz	cdmaOne, GSM850	–	–171	–	dBm/Hz
	925–960 MHz	E-GSM	–	–171	–	dBm/Hz
	1570–1580 MHz	GPS	–	–170	–	dBm/Hz
	1805–1880 MHz	GSM1800	–	–170	–	dBm/Hz
	1930–1990 MHz	GSM1900, cdmaOne, WCDMA	–	–170	–	dBm/Hz
	2110–2170 MHz	WCDMA	–	–170	–	dBm/Hz
	2400–2483 MHz	BT/WLAN	–	–170	–	dBm/Hz
Harmonic level (–5 dBm output power)	9.8–11.570 GHz	2nd harmonic	–	–50	–	dBm/MHz
OFDM EVM ^b	OFDM, BPSK	0 dBm	–26.4	–30.4	–	dB
OFDM EVM ^b	OFDM, 64 QAM	–3 dBm	–29.7	–32.7	–	dB
OFDM EVM ^b	MCS7	–6 dBm	–31.6	–33.6	–	dB
Phase noise	37.4 MHz Crystal, Integrated from 10 kHz to 10 MHz		–	0.7	–	Degrees
Tx power control dynamic range	–		20	–	–	dB
Carrier suppression	–		15	–	–	dBc
Gain control step	–		–	0.25	–	dB
Return loss	$Z_0 = 50\Omega$		–	6	–	dB

- The cellular standards listed indicate only typical usages of that band in some countries. Other standards may also be used within those bands.
- Derate power by 2 dB for temperatures less than –10°C or more than +55°C.

Not Recommended for New Designs

General Spurious Emissions Specifications

Table 40: General Spurious Emissions Specifications

<i>Parameter</i>	<i>Condition/Notes</i>		<i>Min</i>	<i>Typ</i>	<i>Max</i>	<i>Unit</i>
Frequency range	–		2400	–	2500	MHz
General Spurious Emissions						
Tx Emissions	30 MHz < f < 1 GHz	RBW = 100 kHz	–	–	–62	dBm
	1 GHz < f < 12.75 GHz	RBW = 1 MHz	–	–	–47	dBm
	1.8 GHz < f < 1.9 GHz	RBW = 1 MHz	–	–	–53	dBm
	5.15 GHz < f < 5.3 GHz	RBW = 1 MHz	–	–	–53	dBm
Rx/standby Emissions	30 MHz < f < 1 GHz	RBW = 100 kHz	–	–78	–63	dBm
	1 GHz < f < 12.75 GHz	RBW = 1 MHz	–	–68.5 ^a	–53	dBm
	1.8 GHz < f < 1.9 GHz	RBW = 1 MHz	–	–96	–53	dBm
	5.15 GHz < f < 5.3 GHz	RBW = 1 MHz	–	–96	–53	dBm

- a. For frequencies other than 3.2 GHz, the emissions value is –96 dBm. The value presented in table is the result of LO leakage at 3.2 GHz.

Not Recommended for New Designs

Section 19: Internal Regulator Electrical Specifications



Note: Values in this data sheet are design goals and are subject to change based on the results of device characterization.

Functional operation is not guaranteed outside of the specification limits provided in this section.

Core Buck Switching Regulator

Table 41: Core Buck Switching Regulator (CBUCK) Specifications

Specification	Notes	Min	Typ	Max	Units
Input supply voltage (DC), VBAT	DC voltage range inclusive of disturbances.	2.3	3.6	4.8 ^a	V
PWM mode switching frequency, F _{sw}	Forced PWM without FLL enabled.	2.8	4	5.2	MHz
	Forced PWM with FLL enabled.	3.6	4	4.4	MHz
PWM output current	–	–	–	372	mA
Output current limit	–	–	1390	–	mA
Output voltage range	Programmable, 30 mV steps. Default = 1.35V (bits = 0000).	1.2	1.35	1.5	V
PWM output voltage DC accuracy	Includes load and line regulation. Forced PWM mode.	–4	–	4	%
	Total DC accuracy after trim.	–2	–	2	%
PWM ripple voltage, static	Measure with 20 MHz BW limit. Static Load. Max ripple based on: VBAT < 4.8V, Vout = 1.35V, Fsw = 4 MHz, 2.2 μH inductor, L > 0.6 μH, capacitor + Board total-ESR < 20 mΩ, Cout > 1.9 μF, ESL < 200 pH.	–	7	20	mVpp
PWM mode peak efficiency (Peak efficiency is at 200 mA load. The following conditions apply to all inductor types: Forced PWM, 200 mA, Vout = 1.35V, VBAT = 3.6V, Fsw = 4 MHz, at 25°C.)	2.5 x 2 mm LQM2HPN2R2NG0, L = 2 μH, DCR = 80 mΩ ±25%, ACR < 1Ω.	79	85	–	%
	0805-size LQM21PN2R2NGC, L = 2.1 μH, DCR=230 mΩ ±25%, ACR < 2Ω.	78	84	–	%
	0603-size MIPSTZ1608D2R2B, L = 2.2 μH, DCR = 390 mΩ ±30%, ACR < 2Ω.	74	81	–	%

Not Recommended for New Designs

Table 41: Core Buck Switching Regulator (CBUCK) Specifications (Cont.)

Specification	Notes	Min	Typ	Max	Units
PFM mode efficiency	10 mA load current, Vout = 1.35V, VBAT = 3.6V, 20C Cap + Board total-ESR < 20 mΩ, Cout = 4.7 μF, ESL < 200 pH, FLL= OFF 0603-size LQM18PN2R5ND0, L = 2.2 μH, DCR = 240 mΩ ±25%, ACR < 2Ω.	67	77	–	%
LPOM efficiency	1 mA load current, Vout = 1.35V, VBAT = 3.6V, 20C Cap + board total-ESR < 20 mΩ, Cout = 4.7 μF, ESL < 200 pH, FLL = OFF 0603-size LQM18PN2R5ND0, L = 2.2 μH, DCR = 240Ω ±25%, ACR < 2Ω.	55	65	–	%
Start-up time from power down	VIO already on and steady. Time from REG_ON rising edge to CLDO reaching 1.2V. Includes 256 μsec typical Vddc_ok_o delay.	–	903	1106	μs
External inductor, L ^b	–	–	2.2	–	μH
External output capacitor, Cout ^b	Ceramic, X5R, 0402, ESR < 30 mΩ at 4 MHz, ±20%, 6.3V, 4.7 μF, Murata GRM155R60J475M	2 ^c	4.7	–	μF
External input capacitor, Cin ^b	For SR_VDDBATP5V pin. Ceramic, X5R, 0603, ESR < 30 mΩ at 4 MHz, ±20%, 6.3V, 4.7 μF, Murata GRM155R60J475M.	0.67 ^c	4.7	–	μF
Input supply voltage ramp-up time	0 to 4.3V	40	–	–	μs

- The maximum continuous voltage is 4.8V. Voltages up to 5.5V for up to 10 seconds, cumulative duration, over the lifetime of the device are allowed. Voltages as high as 5.0V for up to 250 seconds, cumulative duration, over the lifetime of the device are allowed.
- Refer to *PCB Layout Guidelines and Component Selection for Optimized PMU Performance (4334-AN200-R)* for component selection details.
- The minimum value refers to the residual capacitor value after taking into account part-to-part tolerance, DC-bias, temperature, and aging.

Not Recommended for New Designs

3.3V LDO (LDO3P3)

Table 42: LDO3P3 Specifications

Specification	Notes	Min	Typ	Max	Units
Input supply voltage	Min = 3.3 + 0.1V = 3.4V. Dropout voltage requirement must be met under maximum load for performance specifications.	2.3	3.6	4.8 ^a	V
Output current	–	–	–	50	mA
Output voltage, V _o	Default = 3.3V.	2.4	3.3	3.4	V
Dropout voltage	At maximum load.	–	–	100	mV
Output voltage DC accuracy	Includes line/load regulation.	–5	–	+5	%
Quiescent current	No load.	–	8	–	μA
Line regulation	V _{in} from (V _o + 0.1V) to 4.8V, maximum load.	–0.2	–	+0.2	%V _o /V
Load regulation	Load from 1 mA to 50 mA.	–	0.02	0.05	%V _o /mA
Leakage current	Power-down mode.	–	–	5	μA
PSRR	V _{BAT} ≥ 3.6V, V _o = 2.5V, C _o = 1 μF, maximum load, 100 Hz to 100 kHz.	20	–	–	dB
LDO turn-on time	Chip already powered up.	–	–	100	μs
In-rush current during turn-on	From its output capacitor in a fully-discharged state	–	–	70	mA
External output capacitor, C _o ^b	Ceramic, X5R, 0402, (ESR: 30–200 mΩ), ±10%, 10V	0.44 ^c	1	–	μF
External input capacitor ^b	For SR_VDDBATA5V pin (shared with Bandgap) ceramic, X5R, 0402, (ESR: 30–200 mΩ), ±10%, 10V. Not needed if sharing VBAT 4.7 μF capacitor with SR_VDDBATP5V.	–	1	–	μF

- The maximum continuous voltage is 4.8V. Voltages up to 5.5V for up to 10 seconds, cumulative duration, over the lifetime of the device are allowed. Voltages as high as 5.0V for up to 250 seconds, cumulative duration, over the lifetime of the device are allowed.
- Refer to *PCB Layout Guidelines and Component Selection for Optimized PMU Performance* (4334-AN200-R) for component selection details.
- The minimum value refers to the residual capacitor value after taking into account part-to-part tolerance, DC-bias, temperature, and aging.

Not Recommended for New Designs

2.5V LDO (LDO2P5)

Table 43: LDO2P5 Specifications

Specification	Notes	Min	Typ	Max	Units
Input supply voltage	Min = 2.5V + 0.15V = 2.65V. Dropout voltage requirement must be met under maximum load for performance specifications.	2.3	3.6	4.8 ^a	V
Nominal output voltage	Default = 2.5V.	–	2.5	–	V
Output voltage programmability	Range	2.3	2.5	2.8	V
	Accuracy at any step (including line/load regulation), load > 0.1 mA.	–8	–	8	%
Dropout voltage	At maximum load.	–	–	150	mV
Output current	–	0.1	–	70	mA
Quiescent current	No load. ^b	–	18	27	μA
	Maximum load.	–	1000	1200	μA
Leakage current	Power-down mode.	–	1.5	5	μA
Line regulation	V _{in} from (V _o + 0.15V) to 4.8V, maximum load.	–	–	4.88	mV/V
Load regulation	Load from 1 mA to 70 mA, V _{in} = 3.6V.	–	0.4	0.6	mV/mA
Load step error	Load from 1 mA to 70 mA in 1 μs and 70 mA to 1 mA in 1 μs, V _{in} ≥ V _o + 0.15V, C _o = 2.2 μF.	–	–	70	mV
PSRR	V _{BAT} ≥ 3.6V, V _o = 2.5V, C _o = 2.2 μF, maximum load, 100 Hz to 100 kHz.	20	–	–	dB
LDO turn-on time	Chip already powered up.	–	–	200	μs
In-rush current	V _{in} = V _o + 0.15V to 4.8V, C _o = 2.2 μF, No load.	–	–	250	mA
External output capacitor, C _o ^c	Ceramic, X5R, 0402, (ESR: 5–240 mΩ), ±10%, 10V	0.57 ^d	2.2	4.7	μF
External input capacitor ^b	For SR_VDDBATA5V pin (shared with Bandgap) ceramic, X5R, 0402, (ESR: 30–200 mΩ), ±10%, 10V. Not needed if sharing V _{BAT} 4.7 μF capacitor with SR_VDDBATP5V.	0.14 ^d	1	–	μF

- The maximum continuous voltage is 4.8V. Voltages up to 5.5V for up to 10 seconds, cumulative duration, over the lifetime of the device are allowed. Voltages as high as 5.0V for up to 250 seconds, cumulative duration, over the lifetime of the device are allowed.
- Includes BT min-PMU support current bias.
- Refer to *PCB Layout Guidelines and Component Selection for Optimized PMU Performance (4334-AN200-R)* for component selection details.
- The minimum value refers to the residual capacitor value after taking into account part-to-part tolerance, DC-bias, temperature, and aging.

HSICDVDD LDO

Table 44: HSICDVDD LDO Specifications

Specification	Notes	Min	Typ	Max	Units
Input supply voltage	Min = 1.2V + 0.1V = 1.3V. Dropout voltage requirement must be met under maximum load for performance specifications.	1.3	1.35	1.5	V
Output current	–	–	–	80	mA
Output voltage, V_o	Step size 25 mV. Default = 1.2V.	1.1	1.2	1.275	V
Dropout voltage	At maximum load. Includes 100 m Ω routing resistors at input and output.	–	–	100	mV
Output voltage DC accuracy	Including line/load regulation.	–4	–	4	%
Quiescent current	No load. Dependent on programming. ldo_cntl_i[43], ldo_cntl_i[41] to support different external capacitor loads.	–	182	–	μ A
PSRR at 1 kHz	Input \geq 1.35V, 50 to 300 pF, $V_o = 1.2V$	–	–	–	–
	Load: 80 mA	24	–	–	dB
	Load: 40 mA	39	–	–	dB
PSRR at 10 kHz	Input \geq 1.35V, 50 to 300 pF, $V_o = 1.2V$	–	–	–	–
	Load: 80 mA	24	–	–	dB
	Load: 40 mA	38	–	–	dB
PSRR at 100 kHz	Input \geq 1.35V, 50 to 300 pF, $V_o = 1.2V$	–	–	–	–
	Load: 80 mA	15	–	–	dB
	Load: 40 mA	27	–	–	dB
Output Capacitor, C_o	Internal capacitor = Sum of supply decoupling caps and supply-to-ground routing parasitic capacitance. Output capacitor dependent on programming.	–	1000	–	pF

Not Recommended for New Designs

CLDO

Table 45: CLDO Specifications

Specification	Notes	Min	Typ	Max	Units
Input supply voltage, V_{in}	Min = 1.2 + 0.1V = 1.3V. Dropout voltage requirement must be met under maximum load.	1.2	1.35	1.5	V
Output current	–	0.1	–	150	mA
Output voltage, V_o	Programmable in 25 mV steps. Default = 1.2V	1.1	1.2	1.275	V
Dropout voltage	At max load	–	–	100	mV
Output voltage DC accuracy ^a	Includes line/load regulation	–4	–	+4	%
	After trim. Includes line/load regulation. $V_{in} > V_o + 0.1V$.	–2	–	+2	%
Quiescent current	No load	–	10	–	μ A
Line regulation	V_{in} from ($V_o + 0.1V$) to 1.5V, maximum load	–	–	7	mV/V
Load regulation	Load from 1 mA to 150 mA	–	15	25	μ V/mA
Leakage current	Power-down	–	–	10	μ A
PSRR	@1 kHz, $V_{in} \geq 1.5V$, $C_o = 1 \mu F$	20	–	–	dB
Start-up time of PMU	VIO up and steady. Time from the REG_ON rising edge to the CLDO reaching 1.2V. Includes 256 μ s vddc_ok_o delay.	–	–	1106	μ s
LDO turn-on time	Chip already powered up.	–	–	180	μ s
In-rush current during turn-on	From its output capacitor in a fully-discharged state	–	–	150	mA
External output capacitor, C_o ^b	Total ESR: 30 m Ω –200 m Ω	0.67 ^c	1	–	μ F
External input capacitor	Only use an external input capacitor at the VDD_LDO pin if it is not supplied from the CBUCK output. Total ESR (trace/capacitor): 30 m Ω –200 m Ω	–	1	–	μ F

- Load from 0.1 to 150 mA.
- Refer to *PCB Layout Guidelines and Component Selection for Optimized PMU Performance* (4334-AN200-R) for component selection details.
- The minimum value refers to the residual capacitor value after taking into account the part-to-part tolerance, DC-bias, temperature, and aging.

Not Recommended for New Designs

LNLDO

Table 46: LNLDO Specifications

Specification	Notes	Min	Typ	Max	Units
Input supply voltage, V_{in}	Min = $1.2V_o + 0.1V = 1.3V$. Dropout voltage requirement must be met under maximum load.	1.3	1.35	1.5	V
Output current	–	0.1	–	104	mA
Output voltage, V_o	Programmable in 25 mV steps. Default = 1.2V	1.1	1.2	1.275	V
Dropout voltage	At maximum load	–	–	100	mV
Output voltage DC accuracy ^a	includes line/load regulation	–4	–	+4	%
Quiescent current	No load	–	44	–	μ A
Line regulation	V_{in} from ($V_o + 0.1V$) to 1.5V, max load	–	–	7	mV/V
Load regulation	Load from 1 mA to 104 mA	–	15	25	μ V/mA
Leakage current	Power-down	–	–	10	μ A
Output noise	@30 kHz, 60 mA load, $C_o = 1 \mu$ F @100 kHz, 60 mA load, $C_o = 1 \mu$ F	–	–	60 35	nV/root-Hz nV/root-Hz
PSRR	@ 1kHz, input > 1.3V, $C_o = 1 \mu$ F, $V_o = 1.2V$	20	–	–	dB
Start-up time of PMU	VIO up and steady. Time from the REG_ON rising edge to the LNLDO reaching 1.2V. Includes 256 μ s vddc_ok_o delay.	–	–	1106	μ s
LDO turn-on time	Chip already powered up.	–	–	180	μ s
In-rush current during turn-on	From its output capacitor in a fully-discharged state	–	–	150	mA
External output capacitor, C_o^b	Total ESR (trace/capacitor): 30–200 m Ω	0.67 ^c	1	–	μ F
External input capacitor	Only use an external input capacitor at the VDD_LDO pin if it is not supplied from the CBUCK output. Total ESR (trace/capacitor): 30–200 m Ω	–	1	–	μ F

a. Load from 0.1 to 104 mA.

b. Refer to *PCB Layout Guidelines and Component Selection for Optimized PMU Performance (4334-AN200-R)* for component selection details.

c. The minimum value refers to the residual capacitor value after taking into account the part-to-part tolerance, DC-bias, temperature, and aging.

Not Recommended for New Designs

Section 20: System Power Consumption



Note:

- Values in this data sheet are design goals and are subject to change based on the results of device characterization.
- Unless otherwise stated, these values apply for the conditions specified in [Table 29: "Recommended Operating Conditions and DC Characteristics,"](#) on page 118.

WLAN Current Consumption

The WLAN current consumption measurements are shown in [Table 47](#).

All values in [Table 47](#) are with the Bluetooth core in reset (that is, Bluetooth and FM are off).

Table 47: Typical WLAN Power Consumption

Mode	Bandwidth (MHz)	Band (GHz)	VBAT = 3.6V, VDDIO = 1.8V, T _A 25°C	
			Vbat, mA	Vio ^a , μA
Sleep Modes				
OFF ^b	–	–	0.003	3
SLEEP ^c	–	–	0.003	80
IEEE Power Save, DTIM 1 ^d	–	–	0.525	80
IEEE Power Save DTIM 3 ^d	–	–	0.185	80
Active Modes				
Transmit, –5 dBm ^{e,f}	20	2.4	44	3
Receive ^{g,f}	20	2.4	36	3
CRS ^h	20	2.4	32	3
Transmit, –5 dBm ^{e,f}	20	5	75	3
Receive ^{g,f}	20	5	52	3
CRS ^h	20	5	45	3
Transmit, –5 dBm ^{e,f}	40	2.4	60	3
Receive ^{g,f}	40	2.4	48	3
CRS ^h	40	2.4	44	3

Not Recommended for New Designs

Table 47: Typical WLAN Power Consumption

Mode	Bandwidth (MHz)	Band (GHz)	VBAT = 3.6V, VDDIO = 1.8V, T_A 25°C	
			Vbat, mA	Vio^a, μA
Transmit, -5 dBm ^{e,f}	40	5	71	3
Receive ^{g,f}	40	5	63	3
CRS ^h	40	5	53	3

- a. VIO is specified with all pins idle (not switching) and not driving any loads.
- b. WL_REG_ON and BT_REG_ON low.
- c. Idle, not associated, or inter-beacon.
- d. Beacon Interval = 102.4 ms. Beacon duration = 1 ms @1 Mbps. Average current over 3 DTIM intervals.
- e. Duty cycle is 100%. Excludes external PA contribution.
- f. Measured using packet engine test mode.
- g. Duty cycle is 100%. Carrier sense (CS) detect/packet receive.
- h. Carrier sense (CCA) when no carrier present.

Not Recommended for New Designs

Bluetooth, BLE, and FM Current Consumption

The Bluetooth and FM current consumption measurements are shown in [Table 48](#).



Note:

- The WLAN core is in reset (WL_REG_ON = low) for all measurements provided in [Table 48](#).
- For FM measurements, the Bluetooth core is in Sleep mode.
- The BT current consumption numbers are measured based on GFSK Tx output power = 10 dBm.
- VBAT = 3.6V
- VIO = 1.8V

Table 48: Bluetooth and FM Current Consumption

Operating Mode	VBAT	VIO	Unit
Sleep	9	110	μA
SCO Master	10.18	–	mA
3DH5/3DH1 Master	27.7	–	mA
DM1/DH1 Master	21.12	–	mA
DM3/DH3 Master	25.89	–	mA
DM5/DH5 Master	26.49	–	mA
Standard 1.28s Inquiry scan	158	81	μA
Standard R1 page and 1.28 sec Inquiry Scan	290	112	μA
ACL Link, sniff mode, interval = 500 ms	126	84	μA
BLE Scan	160	82	μA
Adv—Unconnectable 1s	58	115	μA
Adv—Connectable 20 μs	2.32	0.102	mA
Connected 1s	43	108	μA
FM Rx I ² S audio	7.51	–	mA

Section 21: Interface Timing and AC Characteristics

SDIO/gSPI Timing

SDIO Default Mode Timing

SDIO default mode timing is shown by the combination of Figure 42 and Table 49.

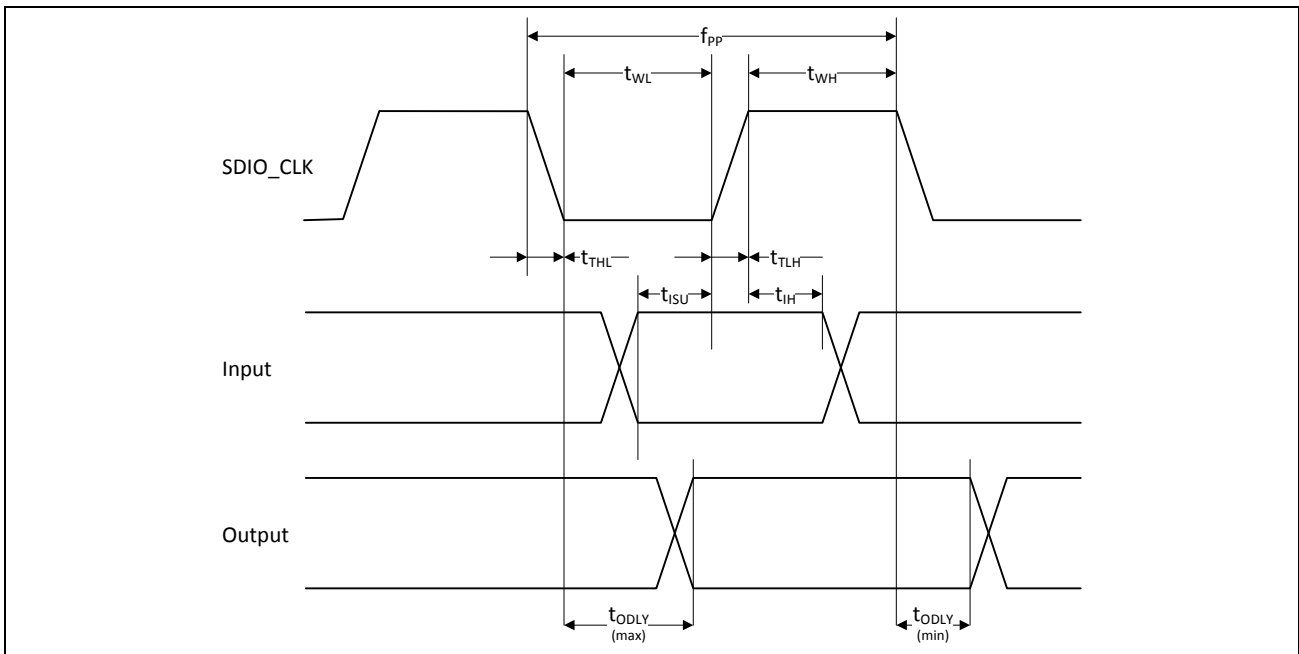

Figure 42: SDIO Bus Timing (Default Mode)

Table 49: SDIO Bus Timing^a Parameters (Default Mode)

Parameter	Symbol	Minimum	Typical	Maximum	Unit
SDIO CLK (All values are referred to minimum VIH and maximum VIL^b)					
Frequency – Data Transfer mode	f _{PP}	0	–	25	MHz
Frequency – Identification mode	f _{OD}	0	–	400	kHz
Clock low time	t _{WL}	10	–	–	ns
Clock high time	t _{WH}	10	–	–	ns
Clock rise time	t _{TLH}	–	–	10	ns
Clock low time	t _{THL}	–	–	10	ns

Not Recommended for New Designs

Table 49: SDIO Bus Timing^a Parameters (Default Mode) (Cont.)

Parameter	Symbol	Minimum	Typical	Maximum	Unit
Inputs: CMD, DAT (referenced to CLK)					
Input setup time	tISU	5	–	–	ns
Input hold time	tIH	5	–	–	ns
Outputs: CMD, DAT (referenced to CLK)					
Output delay time – Data Transfer mode	tODLY	0	–	14	ns
Output delay time – Identification mode	tODLY	0	–	50	ns

- a. Timing is based on $CL \leq 40\text{pF}$ load on CMD and Data.
b. $\min(V_{ih}) = 0.7 \times V_{DDIO}$ and $\max(V_{il}) = 0.2 \times V_{DDIO}$.

Not Recommended for New Designs

SDIO High-Speed Mode Timing

SDIO high-speed mode timing is shown by the combination of Figure 43 and Table 50.

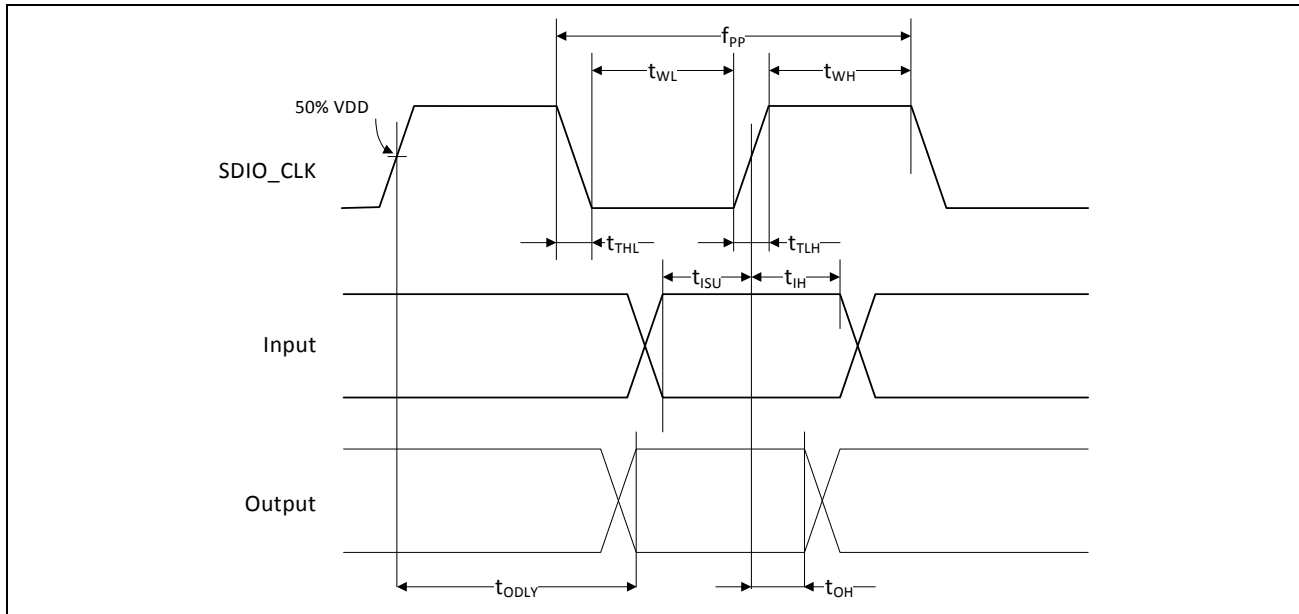

Figure 43: SDIO Bus Timing (High-Speed Mode)

Table 50: SDIO Bus Timing^a Parameters (High-Speed Mode)

Parameter	Symbol	Minimum	Typical	Maximum	Unit
SDIO CLK (all values are referred to minimum VIH and maximum VIL^b)					
Frequency – Data Transfer Mode	f _{PP}	0	–	50	MHz
Frequency – Identification Mode	f _{OD}	0	–	400	kHz
Clock low time	t _{WL}	7	–	–	ns
Clock high time	t _{WH}	7	–	–	ns
Clock rise time	t _{TLH}	–	–	3	ns
Clock low time	t _{THL}	–	–	3	ns
Inputs: CMD, DAT (referenced to CLK)					
Input setup Time	t _{ISU}	6	–	–	ns
Input hold Time	t _{IH}	2	–	–	ns
Outputs: CMD, DAT (referenced to CLK)					
Output delay time – Data Transfer Mode	t _{ODLY}	–	–	14	ns
Output hold time	t _{OH}	2.5	–	–	ns
Total system capacitance (each line)	CL	–	–	40	pF

a. Timing is based on CL ≤ 40pF load on CMD and Data.
 b. min(V_{IH}) = 0.7 × V_{DDIO} and max(V_{IL}) = 0.2 × V_{DDIO}.

Not Recommended for New Designs

gSPI Signal Timing

The gSPI host and device always use the rising edge of clock to sample data.

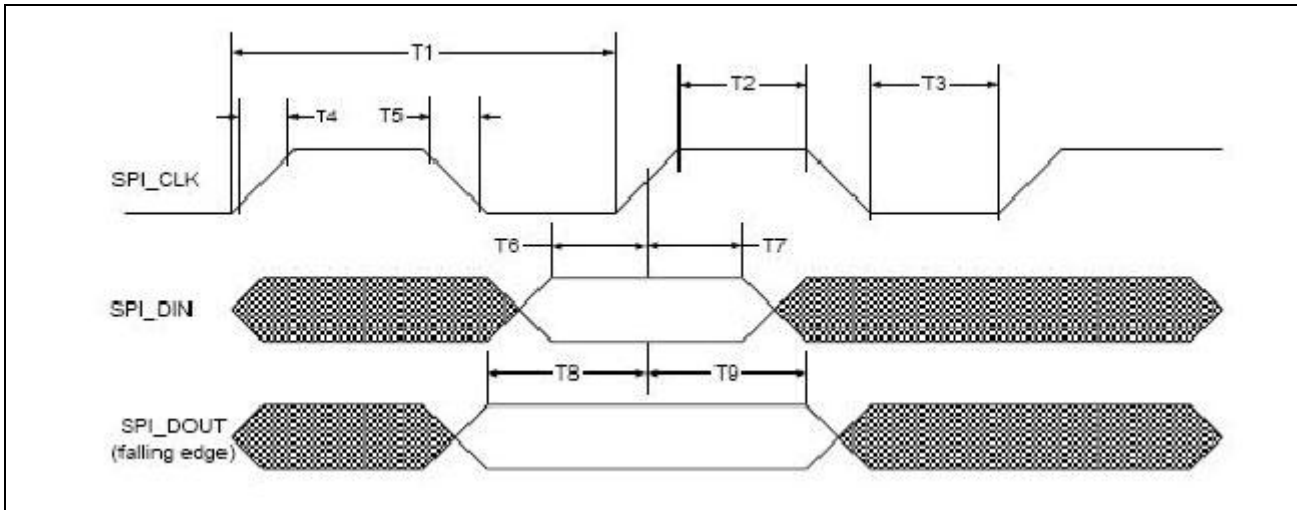

Figure 44: gSPI Timing

Table 51: gSPI Timing Parameters

Parameter	Symbol	Minimum	Maximum	Units	Note
Clock period	T1	20.8	–	ns	$F_{max} = 48 \text{ MHz}$
Clock high/low	T2/T3	$(0.45 \times T1) - T4$	$(0.55 \times T1) - T4$	ns	–
Clock rise/fall time ^a	T4/T5	–	2.5	ns	Measured from 10% to 90% of VDDIO
Input setup time	T6	5.0	–	ns	Setup time, SIMO valid to SPI_CLK active edge
Input hold time	T7	5.0	–	ns	Hold time, SPI_CLK active edge to SIMO invalid
Output setup time	T8	5.0	–	ns	Setup time, SOMI valid before SPI_CLK rising
Output hold time	T9	5.0	–	ns	Hold time, SPI_CLK active edge to SOMI invalid
CSX to clock ^b	–	7.86	–	ns	CSX fall to 1st rising edge
Clock to CSX ^a	–	–	–	ns	Last falling edge to CSX high

- a. Limit applies when SPI_CLK = Fmax. For slower clock speeds, longer rise/fall times are acceptable provided that the transitions are monotonic and the setup and hold time limits are complied with.
- b. SPI_CSx remains active for entire duration of gSPI read/write/write-read transaction (overall words for multiple-word transaction)

Not Recommended for New Designs

HSIC Interface Specifications

Table 52: HSIC Timing Parameters

Parameter	Symbol	Minimum	Typical	Maximum	Unit	Comments
HSIC signaling voltage	V_{DD}	1.1	1.2	1.3	V	–
I/O voltage input low	V_{IL}	–0.3	–	$0.35 \times V_{DD}$	V	–
I/O Voltage input high	V_{IH}	$0.65 \times V_{DD}$	–	$V_{DD} + 0.3$	V	–
I/O voltage output low	V_{OL}	–	–	$0.25 \times V_{DD}$	V	–
I/O voltage output high	V_{OH}	$0.75 \times V_{DD}$	–	–	V	–
I/O pad drive strength	O_D	40	–	60	Ω	Controlled output impedance driver
I/O weak keepers	I_L	20	–	70	μA	–
I/O input impedance	Z_I	100	–	–	k Ω	–
Total capacitive load ^a	C_L	3	–	14	pF	–
Characteristic trace impedance	T_I	45	50	55	Ω	–
Circuit board trace length	T_L	–	–	10	cm	–
Circuit board trace propagation skew ^b	T_S	–	–	15	ps	–
STROBE frequency ^c	F_{STROBE}	239.988	240	240.012	MHz	± 500 ppm
Slew rate (rise and fall) STROBE and DATA ^c	T_{slew}	$0.60 \times V_{DD}$	1.0	1.2	V/ns	Averaged from 30% ~ 70% points
Receiver data setup time (with respect to STROBE) ^c	T_S	300	–	–	ps	Measured at the 50% point
Receiver data hold time (with respect to STROBE) ^c	T_b	300	–	–	ps	Measured at the 50% point

- Total Capacitive Load (C_L), includes device Input/Output capacitance, and capacitance of a 50 Ω PCB trace with a length of 10 cm.
- Maximum propagation delay skew in STROBE or DATA with respect to each other. The trace delay should be matched between STROBE and DATA to ensure that the signal timing is within specification limits at the receiver.
- Jitter and duty cycle are not separately specified parameters, they are incorporated into the values in the table above.

Not Recommended for New Designs

JTAG Timing

Table 53: JTAG Timing Characteristics

<i>Signal Name</i>	<i>Period</i>	<i>Output Maximum</i>	<i>Output Minimum</i>	<i>Setup</i>	<i>Hold</i>
TCK	125 ns	–	–	–	–
TDI	–	–	–	20 ns	0 ns
TMS	–	–	–	20 ns	0 ns
TDO	–	100 ns	0 ns	–	–
JTAG_TRST	250 ns	–	–	–	–

Not Recommended for New Designs

Section 22: Power-Up Sequence and Timing

Sequencing of Reset and Regulator Control Signals

The BCM4334 has three signals that allow the host to control power consumption by enabling or disabling the Bluetooth, WLAN, and internal regulator blocks. These signals are described below. Additionally, diagrams are provided to indicate proper sequencing of the signals for various operational states (see [Figure 45](#), [Figure 46 on page 161](#), and [Figure 47](#) and [Figure 48 on page 162](#)). The timing values indicated are minimum required values; longer delays are also acceptable.

**Note:**

- The WL_REG_ON and BT_REG_ON signals are ORed in the BCM4334. The diagrams show both signals going high at the same time (as would be the case if both REG signals were controlled by a single host GPIO). If two independent host GPIOs are used (one for WL_REG_ON and one for BT_REG_ON), then only one of the two signals needs to be high to enable the BCM4334 regulators.
- The reset requirements for the Bluetooth core are also applicable for the FM core. In other words, if FM is to be used, then the Bluetooth core must be enabled.
- The BCM4334 has an internal power-on reset (POR) circuit. The device will be held in reset for a maximum of 110 ms after VDDC and VDDIO have both passed the POR threshold (see [Table 29: "Recommended Operating Conditions and DC Characteristics," on page 118](#)). Wait at least 150 ms after VDDC and VDDIO are available before initiating SDIO accesses.

Description of Control Signals

- WL_REG_ON:** Used by the PMU to power up the WLAN section. It is also OR-gated with the BT_REG_ON input to control the internal BCM4334 regulators. When this pin is high, the regulators are enabled and the WLAN section is out of reset. When this pin is low the WLAN section is in reset. If both the BT_REG_ON and WL_REG_ON pins are low, the regulators are disabled.
- BT_REG_ON:** Used by the PMU (OR-gated with WL_REG_ON) to power up the internal BCM4334 regulators. If both the BT_REG_ON and WL_REG_ON pins are low, the regulators are disabled. When this pin is low and WL_REG_ON is high, the BT section is in reset.



Note: For both the WL_REG_ON and BT_REG_ON pins, there should be at least a 10 msec time delay between consecutive toggles (where both signals have been driven low). This is to allow time for the CBUCK regulator to discharge. If this delay is not followed, then there may be a VDDIO in-rush current on the order of 36 mA during the next PMU cold start.

Control Signal Timing Diagrams

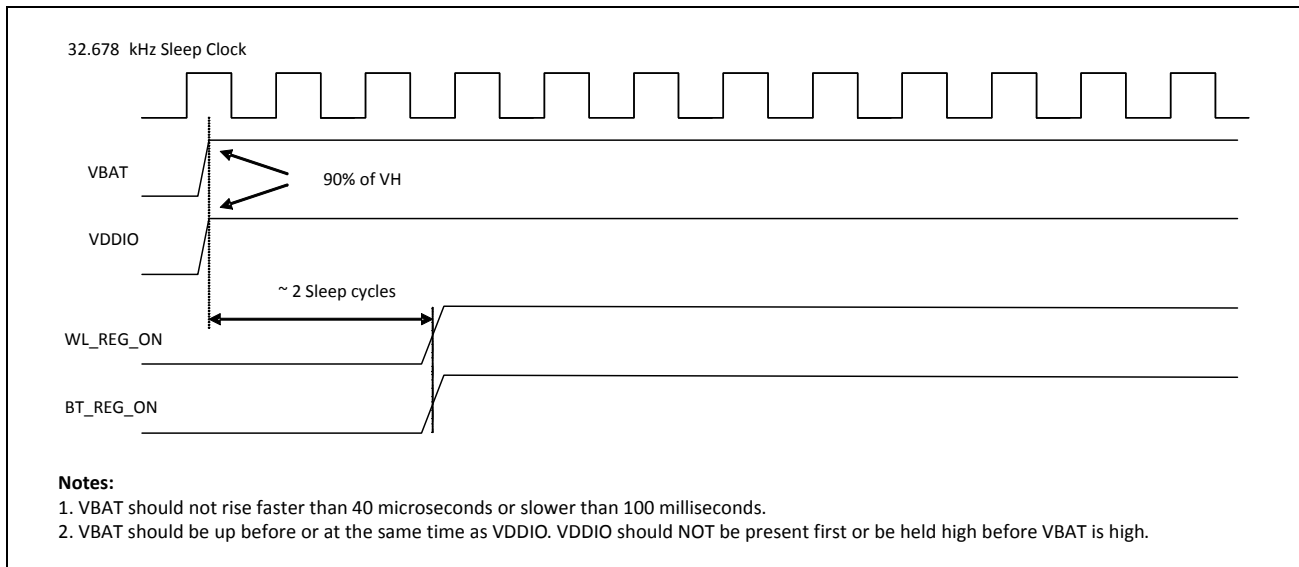

Figure 45: WLAN = ON, Bluetooth = ON

Not Recommended for New Designs

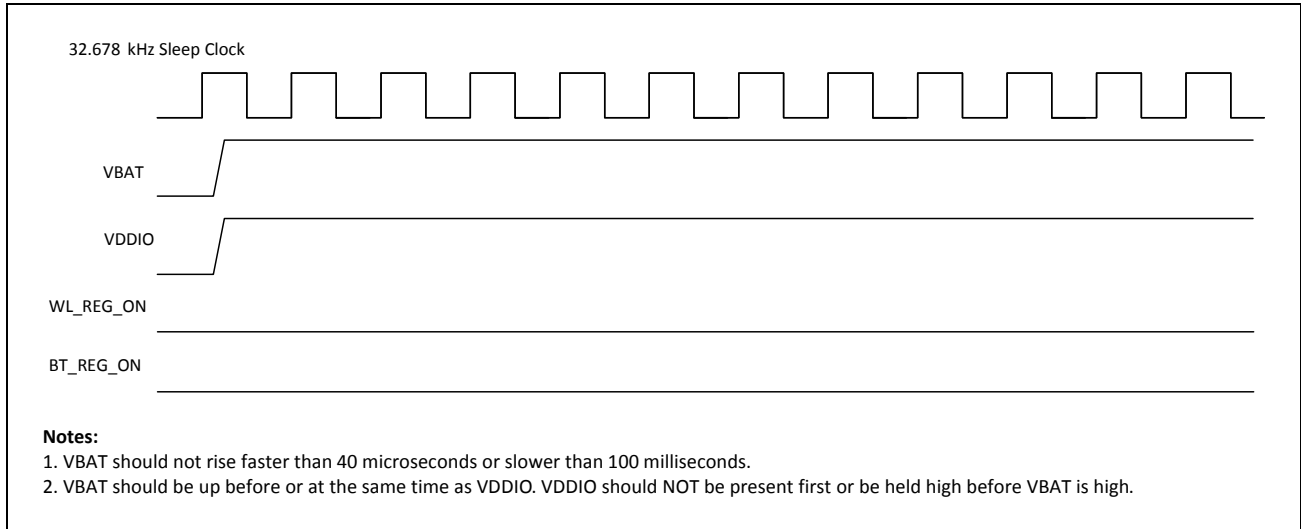

Figure 46: WLAN = OFF, Bluetooth = OFF

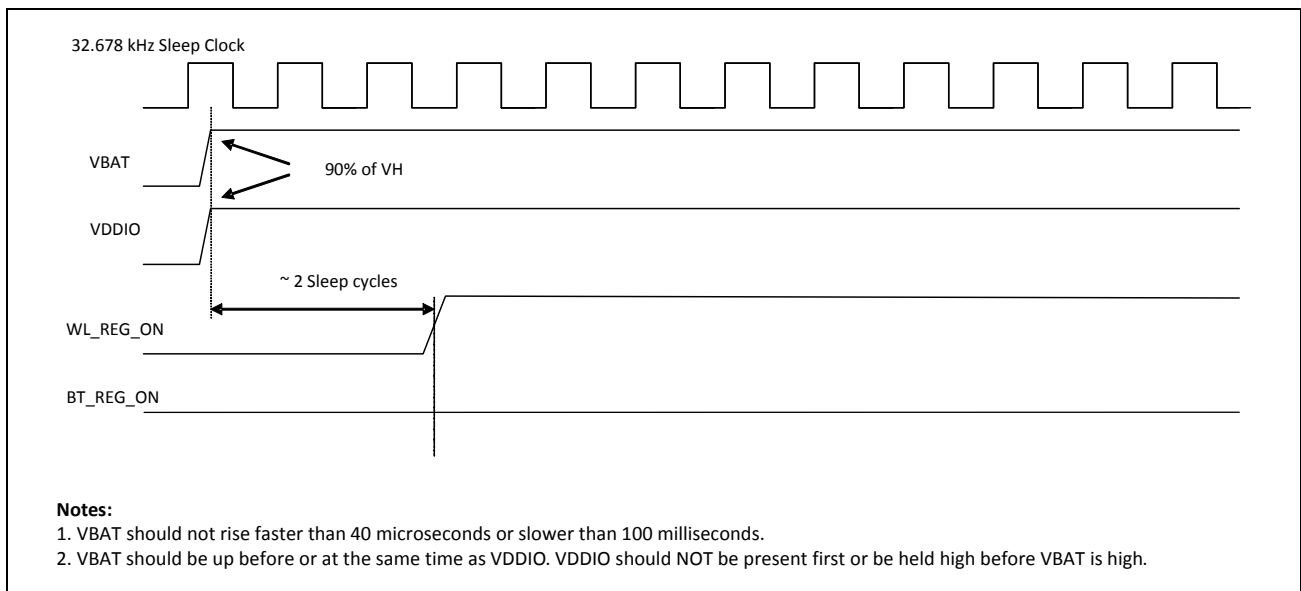

Figure 47: WLAN = ON, Bluetooth = OFF

Not Recommended for New Designs

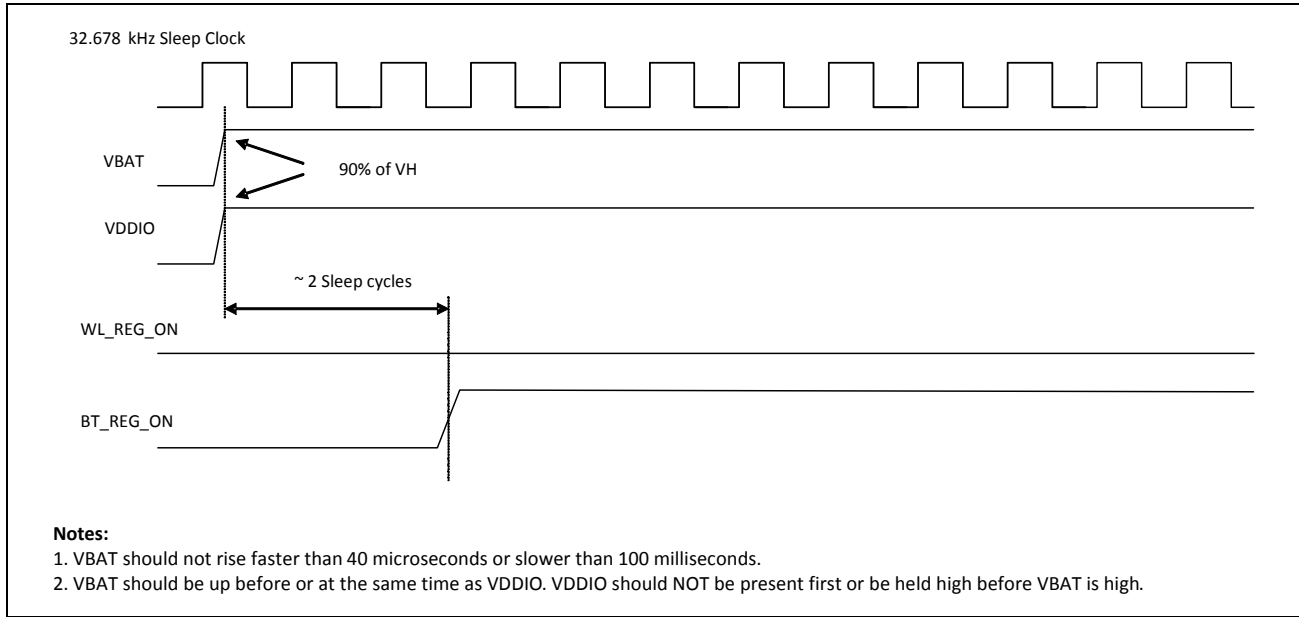

Figure 48: WLAN = OFF, Bluetooth = ON

Not Recommended for New Designs

Section 23: Package Information

Package Thermal Characteristics

Table 54: Package Thermal Characteristics^a

Characteristic	WLBGA	WLSCP
θ_{JA} (°C/W) (value in still air)	40.59	40.26
θ_{JB} (°C/W)	1.82	1.60
θ_{JC} (°C/W)	0.50	0.50
ψ_{JT} (°C/W)	0.98	0.39
ψ_{JB} (°C/W)	12.73	9.34
Maximum Junction Temperature T_j	125°C	125°C
Maximum Power Dissipation (W)	0.87	0.87

- a. No heat sink, $T_A = 70^\circ\text{C}$. This is an estimate, based on a 4-layer PCB that conforms to EIA/JESD51-7 (101.6 mm × 114.3 mm × 1.6 mm) and $P = 0.87\text{W}$ continuous dissipation.

Junction Temperature Estimation and ψ_{JT} Versus θ_{JC}

Package thermal characterization parameter ψ_{JT} yields a better estimation of actual junction temperature (T_j) versus using the junction-to-case thermal resistance parameter θ_{JC} . The reason for this is that θ_{JC} assumes that all the power is dissipated through the top surface of the package case. In actual applications, some of the power is dissipated through the bottom and sides of the package. ψ_{JT} takes into account power dissipated through the top, bottom, and sides of the package. The equation for calculating the device junction temperature is:

$$T_j = T_T + P \times \psi_{JT}$$

Where:

- T_j = Junction temperature at steady-state condition (°C)
- T_T = Package case top center temperature at steady-state condition (°C)
- P = Device power dissipation (Watts)
- ψ_{JT} = Package thermal characteristics; no airflow (°C/W)

Environmental Characteristics

For environmental characteristics data, see [Table 27: “Environmental Ratings,” on page 117](#).

Section 24: Mechanical Information

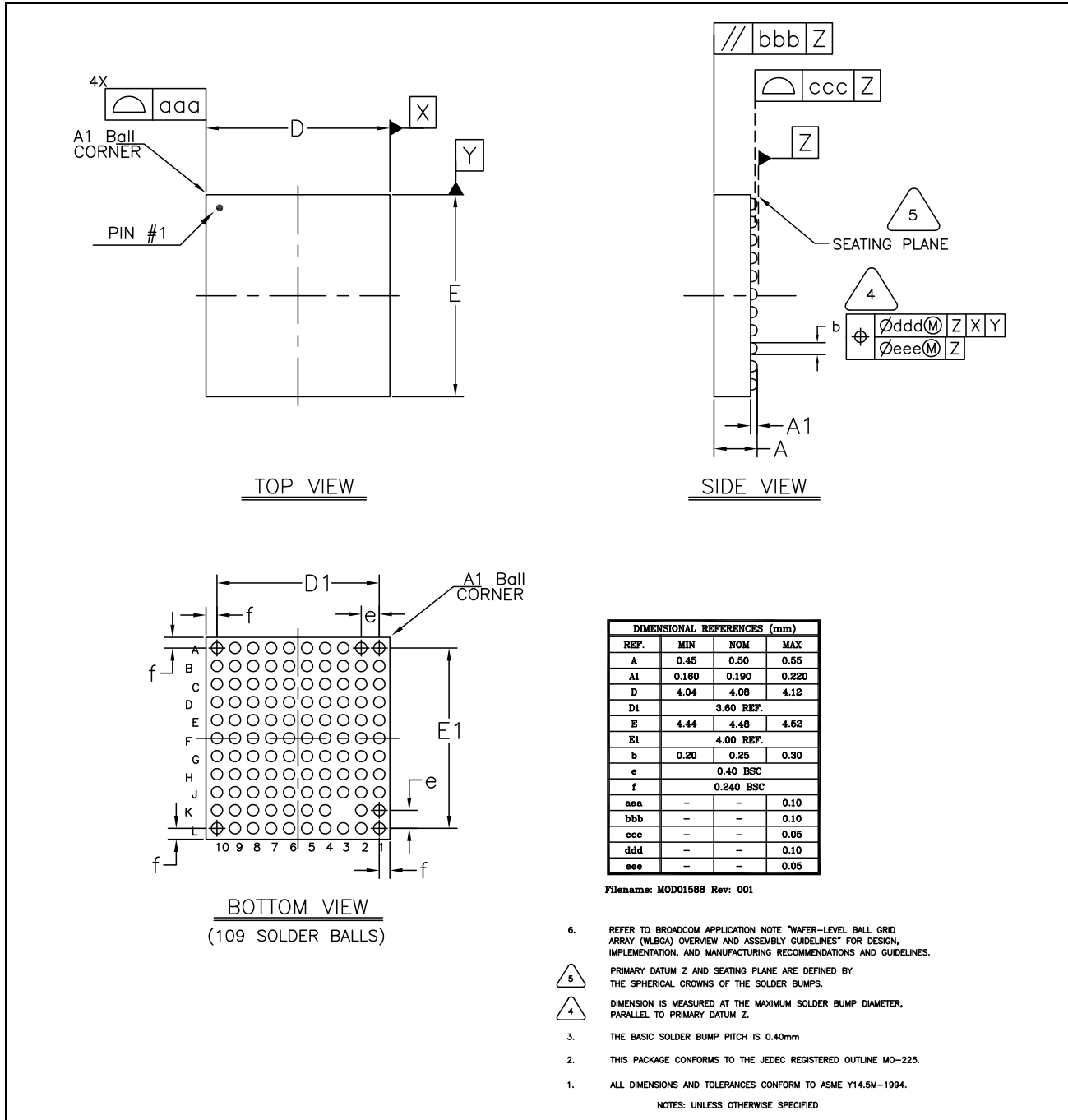

Figure 49: 109-Ball WLBGA Package Mechanical Information

Not Recommended for New Designs

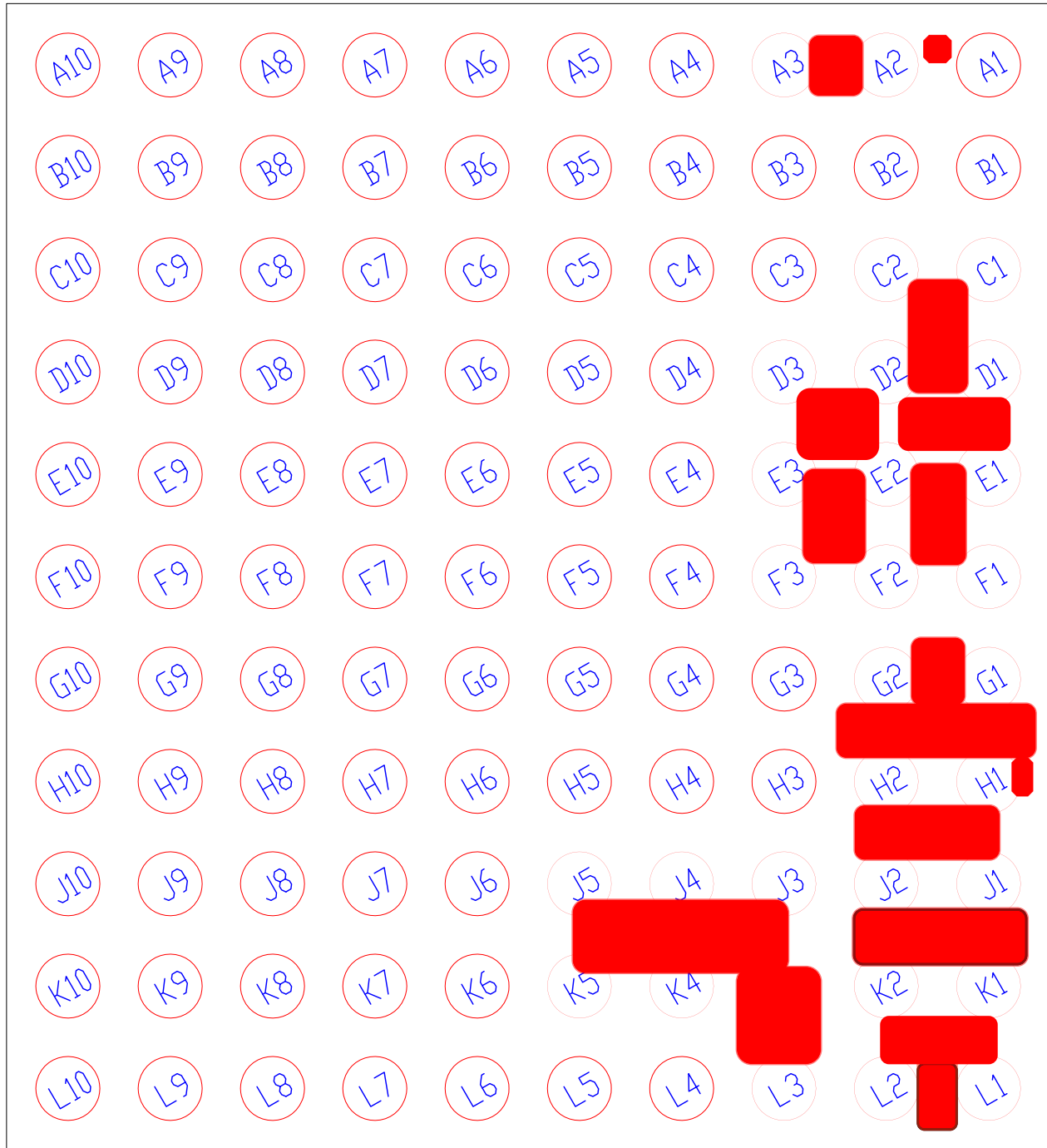

Figure 50: WLBGA Keep-Out Areas for PCB Layout — Bottom View



Note: No top-layer metal is allowed in keep-out areas.

Not Recommended for New Designs

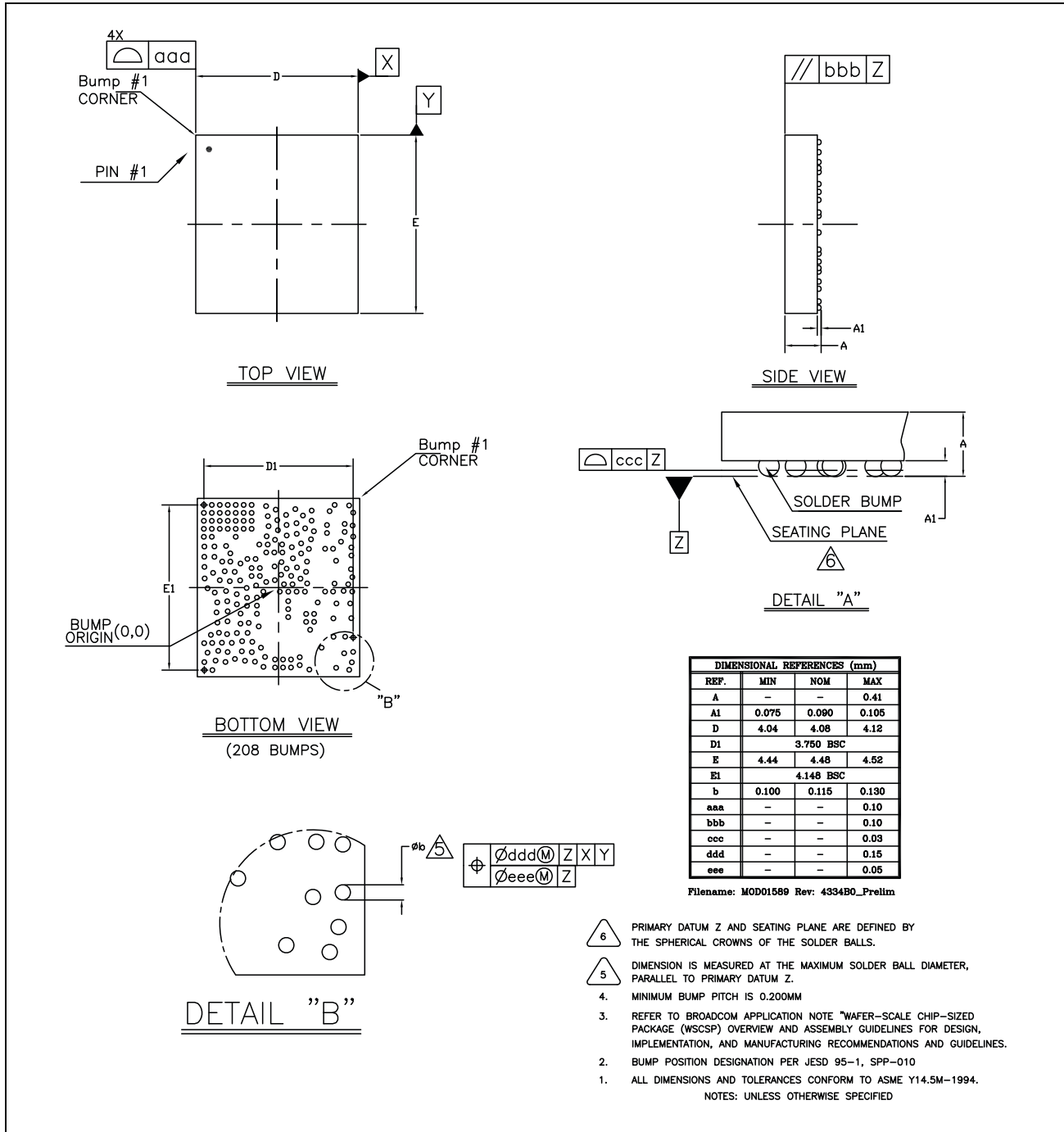

Figure 51: 208-Bump WLCSP Package Mechanical Information



Caution! This WLCSP bump map information applies only to the B series of the BCM4334. For information on the A0/A1 version refer to the previous version of this data sheet.

Not Recommended for New Designs

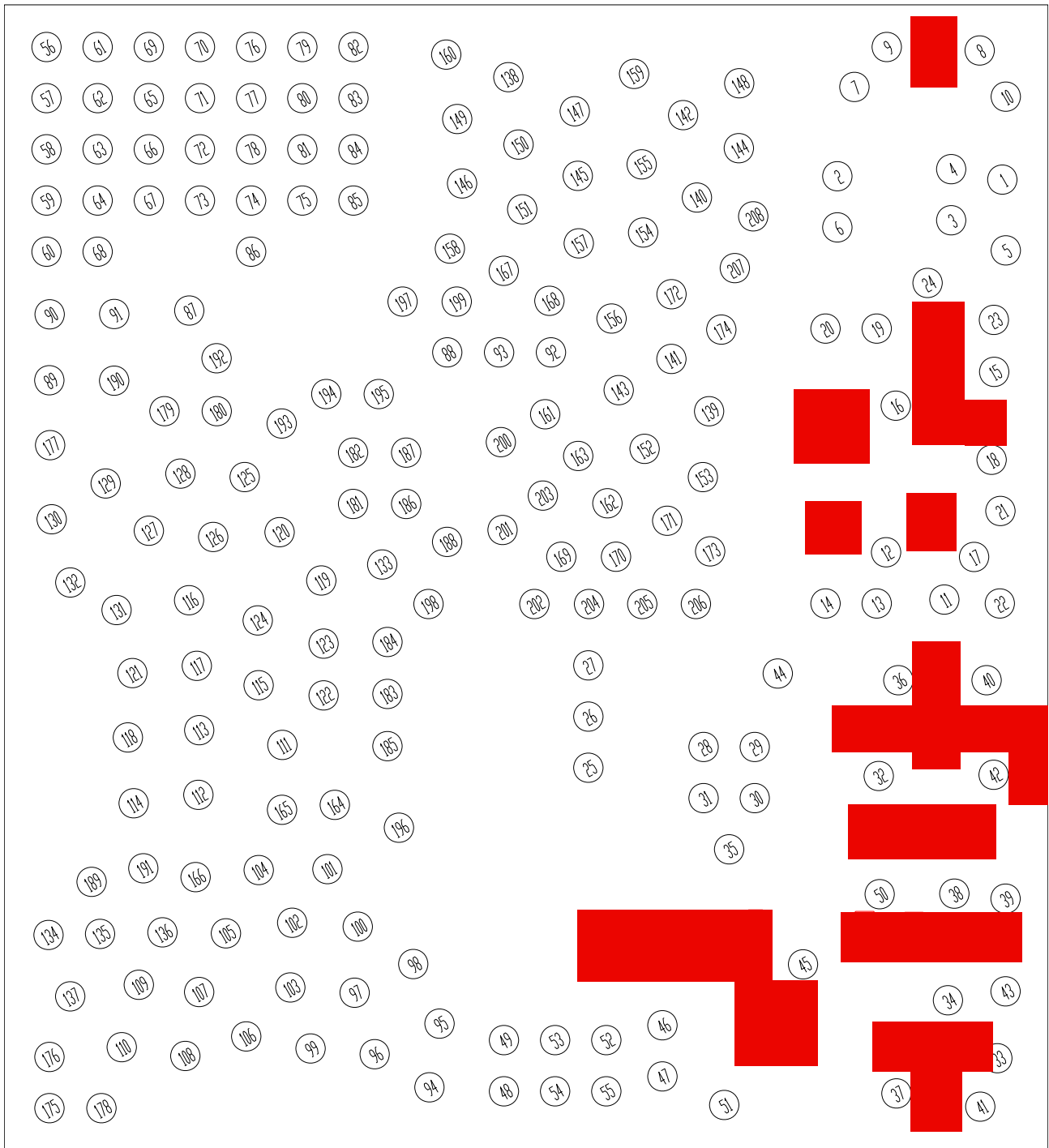

Figure 52: WLCSP Keep-Out Areas for PCB Layout — Bottom View with Bumps Facing Up



Note: No top-layer metal is allowed in keep-out areas.

Not Recommended for New Designs

Section 25: Ordering Information

<i>Part Number</i>	<i>Package</i>	<i>Description</i>	<i>Operating Ambient Temperature</i>
BCM4334XKUBG	109 ball WLBGA (4.08 mm × 4.48 mm, 0.4 mm pitch)	Dual-band 2.4 GHz and 5 GHz WLAN + BT 4.0 + FM	–30°C to +85°C
BCM4334XKWBG	208 bump WLCSP (4.08 mm × 4.48 mm, 0.2 mm pitch)	Dual-band 2.4 GHz and 5 GHz WLAN + BT 4.0 + FM	–30°C to +85°C

Not Recommended for New Designs

Not Recommended for New Designs

Broadcom® Corporation reserves the right to make changes without further notice to any products or data herein to improve reliability, function, or design.

Information furnished by Broadcom Corporation is believed to be accurate and reliable. However, Broadcom Corporation does not assume any liability arising out of the application or use of this information, nor the application or use of any product or circuit described herein, neither does it convey any license under its patent rights nor the rights of others.

Connecting
everything®



BROADCOM CORPORATION

5300 California Avenue

Irvine, CA 92617

© 2013 by BROADCOM CORPORATION. All rights reserved.

Phone: 949-926-5000

Fax: 949-926-5203

E-mail: info@broadcom.com

Web: www.broadcom.com