

RoHS Compliant Product  
A suffix of "-C" specifies halogen & lead-free

## DESCRIPTION

The BCP1898 is designed for switching applications.

## MARKING



## SOT-89

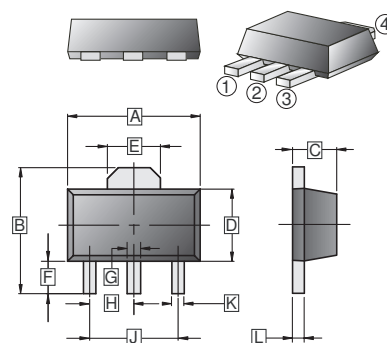

## CLASSIFICATION OF $h_{FE}$

Product-Rank	BCP1898-P	BCP1898-Q	BCP1898-R
Range	82~180	120~270	180~390

## PACKAGE INFORMATION

Package	MPQ	LeaderSize
SOT-89	1K	7' inch

REF.	Millimeter		REF.	Millimeter	
	Min.	Max.		Min.	Max.
A	4.40	4.60	G	0.40	0.58
B	3.94	4.25	H	1.50	TYP
C	1.40	1.60	J	3.00	TYP
D	2.30	2.60	K	0.32	0.52
E	1.50	1.70	L	0.35	0.44
F	0.89	1.2			

## ABSOLUTE MAXIMUM RATINGS ( $T_A = 25^\circ\text{C}$ unless otherwise specified)

Parameter	Symbol	Ratings	Unit
Collector-Base Voltage	$V_{CBO}$	100	V
Collector-Emitter Voltage	$V_{CEO}$	80	V
Emitter-Base Voltage	$V_{EBO}$	5.0	V
Collector Current	$I_C$	1	A
	$I_{CP}$ (Single pulse $P_w=20\text{ms}$ )	2	
Total Power Dissipation	$P_D$	500	mW
Junction & Storage temperature	$T_J, T_{STG}$	150, -55~150	$^\circ\text{C}$

## ELECTRICAL CHARACTERISTICS ( $T_A = 25^\circ\text{C}$ unless otherwise specified)

Parameter	Symbol	Min.	Typ.	Max.	Unit	Test Conditions
Collector-base breakdown voltage	$BV_{CBO}$	100	-	-	V	$I_C=50\mu\text{A}$
Collector-emitter breakdown voltage	$BV_{CEO}$	80	-	-	V	$I_C=1\text{mA}$
Emitter-base breakdown voltage	$BV_{EBO}$	5	-	-	V	$I_E=50\mu\text{A}$
Collector cut-off current	$I_{CBO}$	-	-	1	$\mu\text{A}$	$V_{CB}=80\text{V}$
Emitter cut-off current	$I_{EBO}$	-	-	1	$\mu\text{A}$	$V_{EB}=4\text{V}$
DC current gain	$h_{FE}$	82	-	390		$V_{CE}=3\text{V}, I_C=500\text{mA}$
Collector-emitter saturation voltage	$V_{CE(sat)}$	-	-	400	mV	$I_C=500\text{mA}, I_B=20\text{mA}$
Transition frequency	$f_T$	-	100	-	MHz	$V_{CE}=10\text{V}, I_C=50\text{mA}, f=100\text{MHz}$
Output Capacitance	$C_{OB}$	-	25	-	pF	$V_{CB}=10\text{V}, I_E=0, f=1\text{MHz}$

**CHARACTERISTIC CURVES**

