

Medium Power PNP Epitaxial Planar Transistor

BCP69L3

Features

- For AF driver and output stage
- Low saturation voltage
- High collector current.
- Complementary to BCP68L3
- Pb-free lead plating and halogen-free package

Symbol

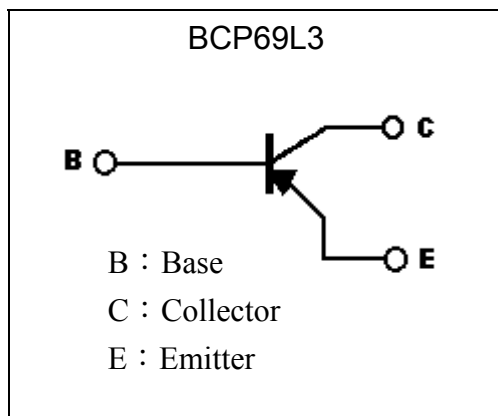

Outline

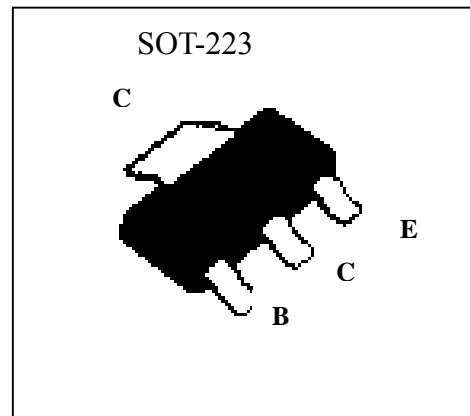

Ordering Information

Device	Package	Shipping
BCP69L3-XX-T3-G	SOT-223 (Pb-free lead plating and halogen-free package)	2500 pcs / tape & reel

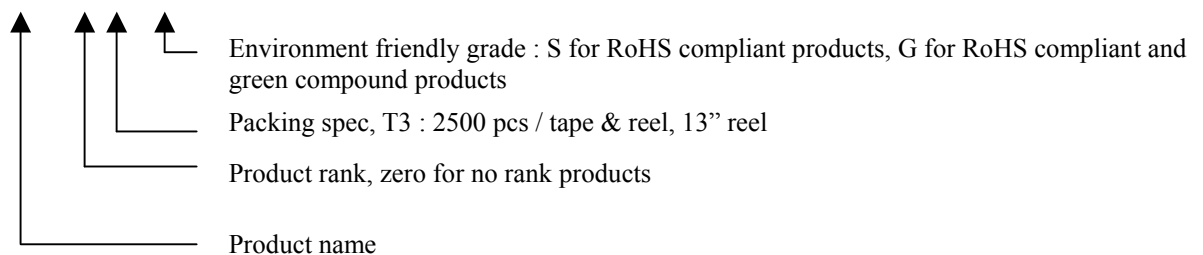



Absolute Maximum Ratings (Ta=25°C)

Parameter	Symbol	Limits	Unit
Collector-Base Voltage	V _{CBO}	-25	V
Collector-Emitter Voltage	V _{CEO}	-20	V
Emitter-Base Voltage	V _{EBO}	-5	V
Collector Current(DC)	I _C	-1	A
Peak Collector Current	I _{CM}	-2	A
Peak Base Current	I _{BM}	-200	mA
Power Dissipation @T _A =25°C	P _d	0.625 (Note 1&2)	W
		1 (Note 1&3)	
		1.4 (Note 1&4)	
Junction Temperature	T _j	150	°C
Storage Temperature	T _{stg}	-55~+150	°C

Note : 1. SOT-223(SC-73) standard mounting conditions.

2. Device mounted on a FR-4 PCB, single side copper, tin plated, standard footprint for SOT-223
3. Device mounted on a FR-4 PCB, single side copper, tin plated, 1 cm² collector mounting pad.
4. Device mounted on a FR-4 PCB, single side copper, tin plated, 6 cm² collector mounting pad.

Characteristics (Ta=25°C)

Symbol	Min.	Typ.	Max.	Unit	Test Conditions
BV _{CBO}	-25	-	-	V	I _C =-10μA, I _E =0
BV _{CEO}	-20	-	-	V	I _C =-30mA, I _B =0
BV _{EBO}	-5	-	-	V	I _E =-10μA, I _C =0
I _{CBO}	-	-	-100	nA	V _{CB} =-25V, I _E =0
I _{EBO}	-	-	-10	μA	V _{EB} =-5V, I _C =0
*V _{CE(sat)}	-	-	-0.5	V	I _C =-1A, I _B =-100mA
*V _{BE(on)1}	-	-0.6	-	V	V _{CE} =-10V, I _C =-5mA
*V _{BE(on)2}	-	-	-1.0	V	V _{CE} =-1V, I _C =-1A
*h _{FE1}	50	-	-	-	V _{CE} =-10V, I _C =-5mA
*h _{FE2}	100	-	400	-	V _{CE} =-1V, I _C =-500mA
f _T	-	100	-	MHz	V _{CE} =-5V, I _C =-100mA, f=100MHz

*Pulse Test : Pulse Width ≤380μs, Duty Cycle≤2%

Classification Of hFE 2

Rank	16	25
Range	100~250	160~400

Typical Characteristics

Current Gain vs Collector Current

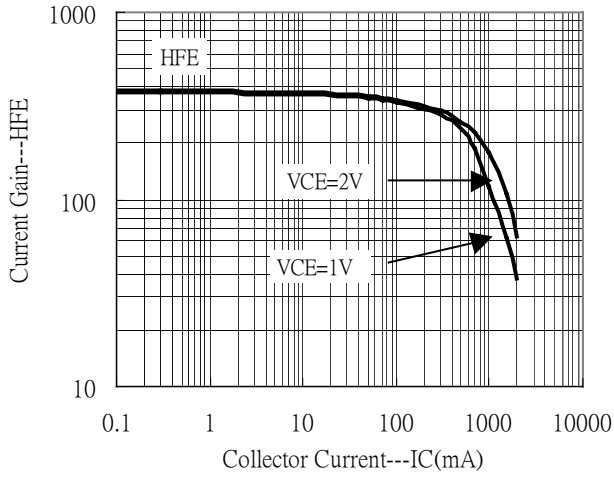

Saturation Voltage vs Collector Current

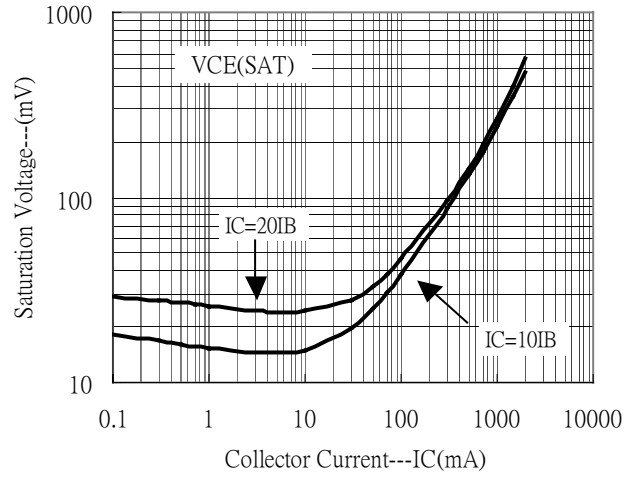

Saturation Voltage vs Collector Current

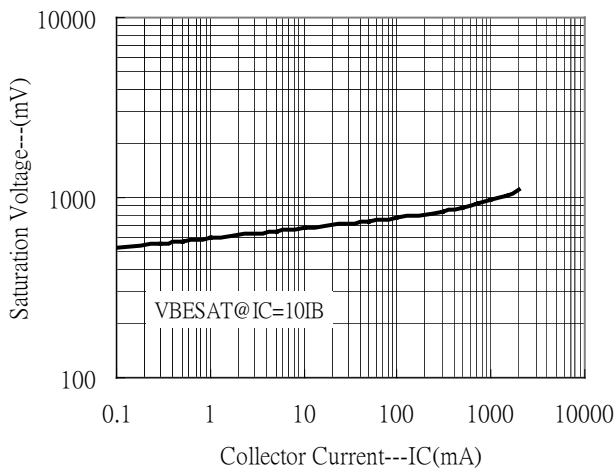

On Voltage vs Collector Current

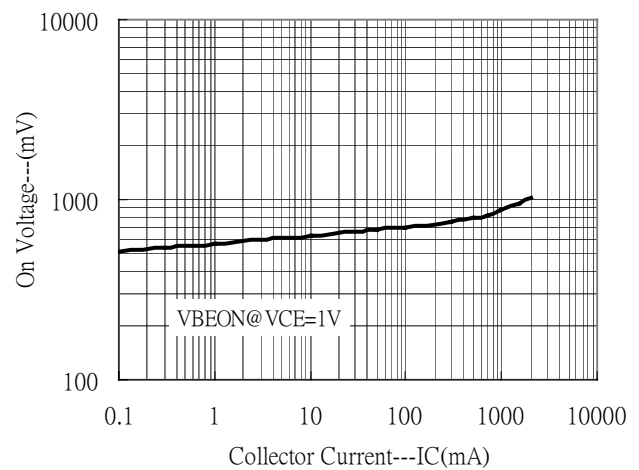

Power Derating Curves

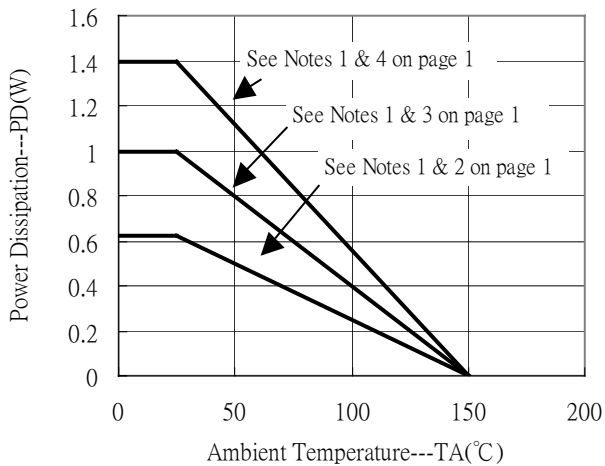

Reel Dimension

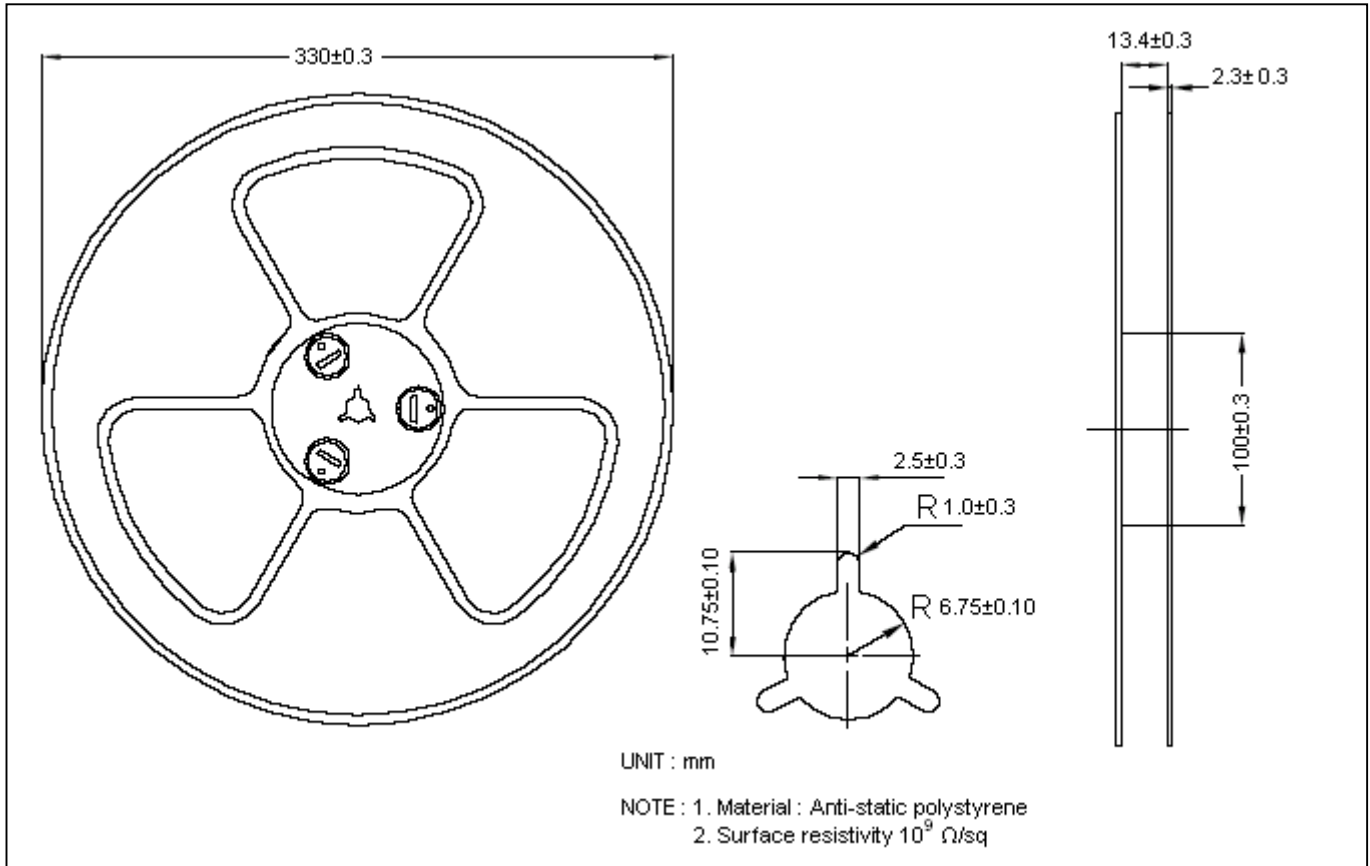

Carrier Tape Dimension

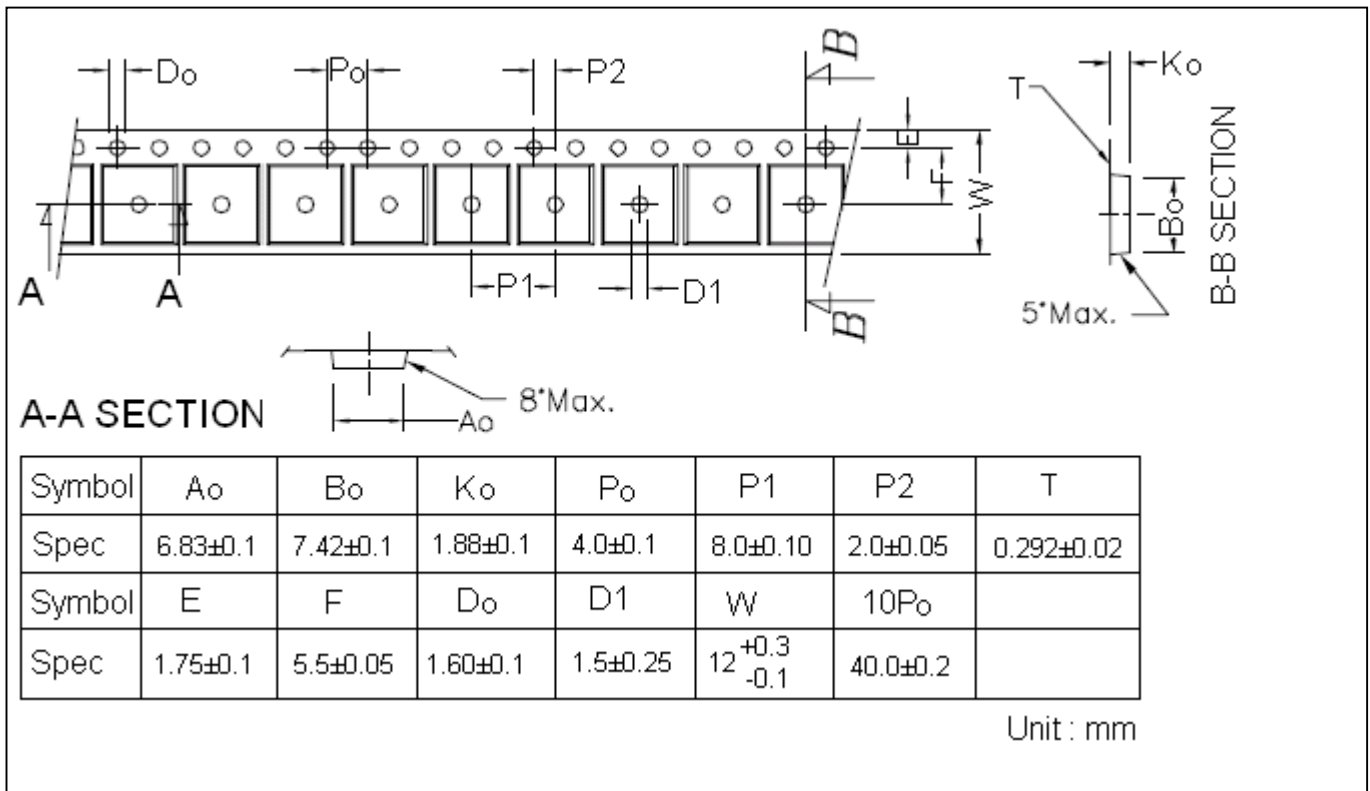

Recommended wave soldering condition

Product	Peak Temperature	Soldering Time
Pb-free devices	260 +0/-5 °C	5 +1/-1 seconds

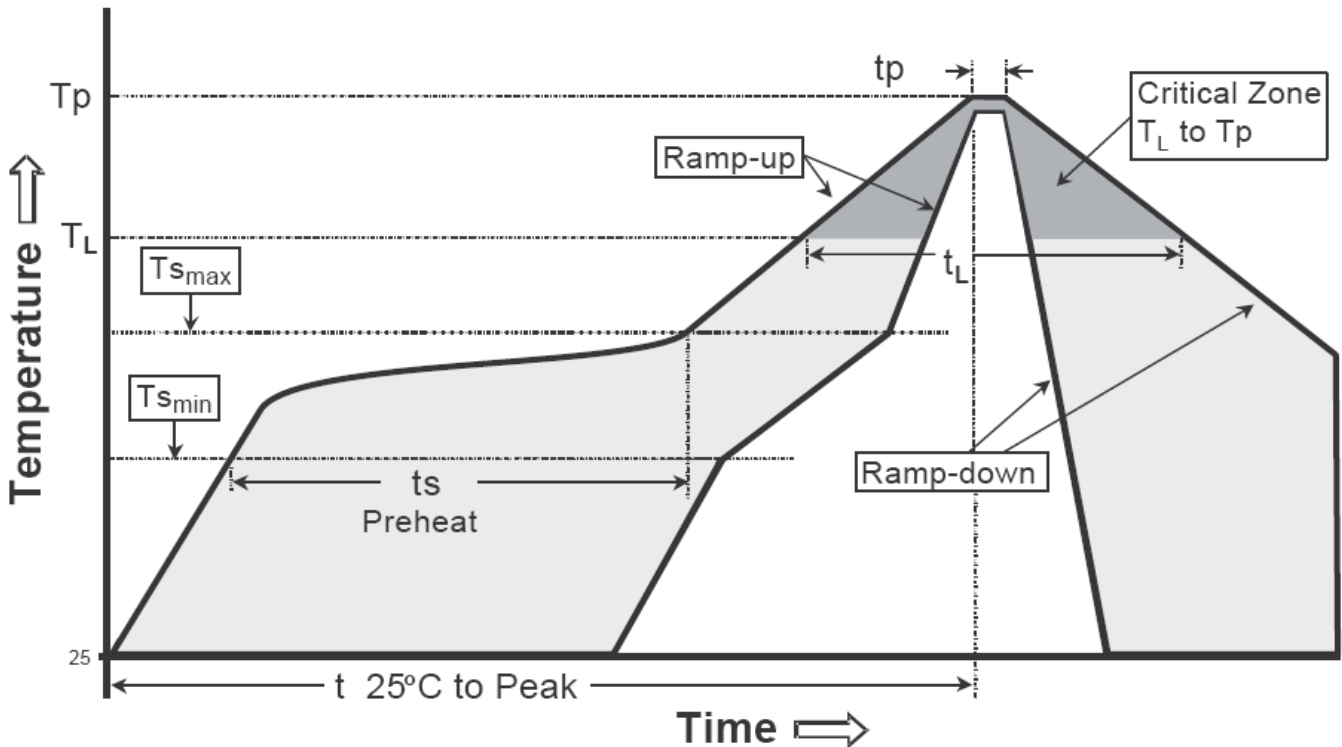
Recommended temperature profile for IR reflow

Profile feature	Sn-Pb eutectic Assembly	Pb-free Assembly
Average ramp-up rate (T _{smax} to T _p)	3°C/second max.	3°C/second max.
Preheat		
-Temperature Min(T _{s min})	100°C	150°C
-Temperature Max(T _{s max})	150°C	200°C
-Time(t _{s min} to t _{s max})	60-120 seconds	60-180 seconds
Time maintained above:		
-Temperature (T _L)	183°C	217°C
- Time (t _L)	60-150 seconds	60-150 seconds
Peak Temperature(T _P)	240 +0/-5 °C	260 +0/-5 °C
Time within 5°C of actual peak temperature(t _p)	10-30 seconds	20-40 seconds
Ramp down rate	6°C/second max.	6°C/second max.
Time 25 °C to peak temperature	6 minutes max.	8 minutes max.

Note : All temperatures refer to topside of the package, measured on the package body surface.

SOT-223 Dimension

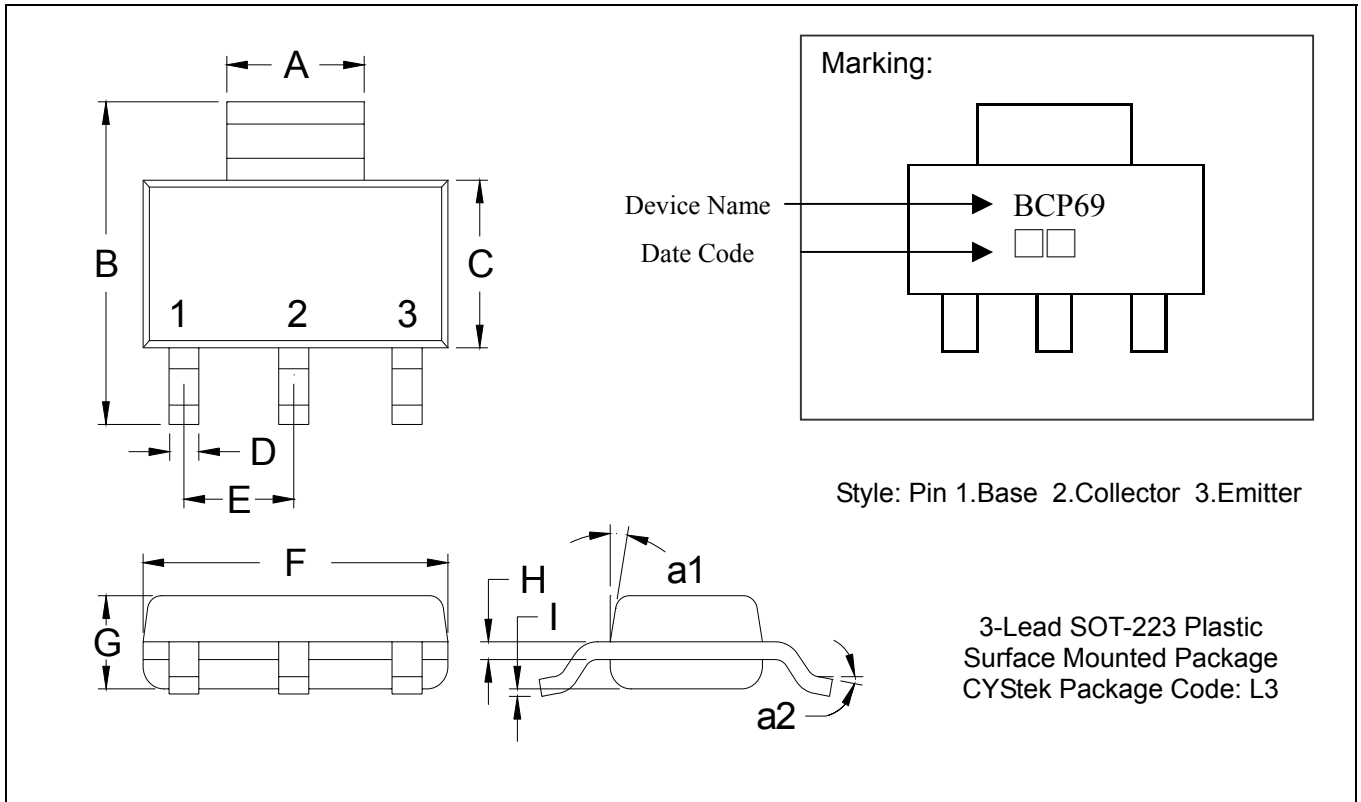

*: Typical

DIM	Inches		Millimeters		DIM	Inches		Millimeters	
	Min.	Max.	Min.	Max.		Min.	Max.	Min.	Max.
A	0.1142	0.1220	2.90	3.10	G	0.0551	0.0709	1.40	1.80
B	0.2638	0.2874	6.70	7.30	H	0.0098	0.0138	0.25	0.35
C	0.1299	0.1457	3.30	3.70	I	0.0008	0.0039	0.02	0.10
D	0.0236	0.0315	0.60	0.80	a1	*13°	-	*13°	-
E	*0.0906	-	*2.30	-	a2	0°	10°	0°	10°
F	0.2480	0.2638	6.30	6.70					

Notes: 1.Controlling dimension: millimeters.
 2.Maximum lead thickness includes lead finish thickness, and minimum lead thickness is the minimum thickness of base material.
 3.If there is any question with packing specification or packing method, please contact your local CYStek sales office.

Material:

- Lead: Pure tin plated.
- Mold Compound: Epoxy resin family, flammability solid burning class: UL94V-0.

Important Notice:

- All rights are reserved. Reproduction in whole or in part is prohibited without the prior written approval of CYStek.
- CYStek reserves the right to make changes to its products without notice.
- CYStek **semiconductor products are not warranted to be suitable for use in Life-Support Applications, or systems.**
- CYStek assumes no liability for any consequence of customer product design, infringement of patents, or application assistance.