

Description

The BCR402UW6 monolithically integrates a transistor, diodes and resistors to function as a Constant Current Regulator (CCR) for LED driving. The device regulates with a preset 20mA nominal that can be adjusted with an external resistor up to 100mA. It is designed for driving LEDs in strings and will reduce current at increasing temperatures to self-protect. Operating as a series linear CCR for LED string current control, it can be used in applications with supply voltages up to 40V.

With no need for additional external components, this CCR is fully integrated into SOT26 (SC74R) minimizing PCB area and component count.

Features

- LED Constant Current Regulator Using PNP Emitter-Follower with Emitter Resistor to Current Limit
- $I_{OUT} = 20\text{mA} \pm 10\%$ Constant Current (Preset)
- I_{OUT} up to 100mA Adjustable with an External Resistor
- $V_S = 40\text{V}$ Supply Voltage
- P_D up to 1W in SOT26 (SC74R)
- LED Dimming Using PWM up to 25kHz
- Negative Temperature Coefficient (NTC) Reduces I_{OUT} with Increasing Temperature
- Parallel Devices to Increase Regulated Current
- **Totally Lead-Free & Fully RoHS Compliant (Notes 1 & 2)**
- **Halogen and Antimony Free. "Green" Device (Note 3)**
- **Qualified to AEC-Q101 Standards for High Reliability**
- **An Automotive-Compliant Part is Available Under Separate Data Sheet ([BCR402UW6Q](#))**

Applications

Constant Current Regulation (CCR) in:

- Emergency Lighting
- Signage, Advertising, Decorative and Architectural Lighting
- Retail Lighting in Fridge, Freezer Case and Vending Machines

Mechanical Data

- Case: SOT26 (SC74R)
- Case Material: Molded Plastic. "Green" Molding Compound. UL Flammability Rating 94V-0
- Moisture Sensitivity: Level 1 per J-STD-020
- Terminals: Finish - Matte Tin Plated Leads, Solderable per MIL-STD-202, Method 208
- Weight: 0.018 grams (Approximate)

SOT26 (SC74R)



Top View

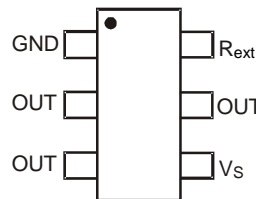
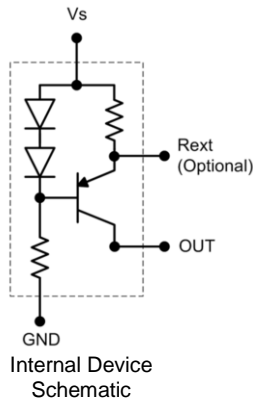

Pin Name	Pin Function
V_S	Supply Voltage
OUT	Regulated Output Current
R_{ext}	External resistor for adjusting Output Current
GND	Power Ground

Ordering Information (Note 4)

Product	Marking	Reel Size (inches)	Tape Width (mm)	Quantity per Reel
BCR402UW6-7	402	7	8	3,000

- Notes:
1. No purposely added lead. Fully EU Directive 2002/95/EC (RoHS), 2011/65/EU (RoHS 2) & 2015/863/EU (RoHS 3) compliant.
 2. See http://www.diodes.com/quality/lead_free/ for more information about Diodes Incorporated's definitions of Halogen- and Antimony-free, "Green" and Lead-free.
 3. Halogen- and Antimony-free "Green" products are defined as those which contain <900ppm bromine, <900ppm chlorine (<1500ppm total Br + Cl) and <1000ppm antimony compounds.
 4. For packaging details, go to our website at <https://www.diodes.com/design/support/packaging/diodes-packaging/>.

Marking Information

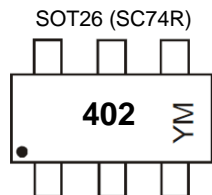

402 = Part Marking (See Ordering Information)
 YM = Date Code Marking
 Y = Year (ex: E = 2017)
 M = Month (ex: 9 = September)

Date Code Key

Year	2017	2018	2019	2020	2021	2022	2023
Code	E	F	G	H	I	J	k

Month	Jan	Feb	Mar	Apr	May	Jun	Jul	Aug	Sep	Oct	Nov	Dec
Code	1	2	3	4	5	6	7	8	9	O	N	D

Absolute Maximum Ratings (Voltage relative to GND, @T_A = +25°C, unless otherwise specified.)

Characteristic	Symbol	Value	Unit
Supply Voltage	V _S	40	V
Output Current	I _{OUT}	100	mA
Output Voltage	V _{OUT}	40	V
Reverse Voltage Between All Terminals	V _R	0.5	V

Thermal Characteristics

Characteristic	Symbol	Value	Unit
Power Dissipation	P _D	(Note 5)	1,190
		(Note 6)	912
Thermal Resistance, Junction to Ambient	R _{θJA}	(Note 5)	105
		(Note 6)	137
Thermal Resistance, Junction to Lead	R _{θJL}	50	°C/W
Recommended Operating Junction Temperature Range	T _J	-55 to +150	
Maximum Operating Junction and Storage Temperature Range	T _J , T _{STG}	-65 to +150	°C

ESD Ratings (Note 8)

Characteristics	Symbols	Value	Unit	JEDEC Class
Electrostatic Discharge – Human Body Model	ESD HBM	800	V	1B
Electrostatic Discharge – Machine Model	ESD MM	300	V	B

- Notes:
- For a device mounted with the OUT leads on 50mm x 50mm 2oz copper that is on a single-sided 1.6mm FR-4 PCB; device is measured under still air conditions while operating in steady-state.
 - Same as Note 5, except mounted on 15mm x 15mm 1oz copper.
 - R_{θJL} = Thermal resistance from junction to solder-point (at the end of the OUT leads).
 - Refer to JEDEC specification JESD22-A114 and JESD22-A115.

Electrical Characteristics (@T_A = +25°C, unless otherwise specified.)

Characteristic	Symbol	Min	Typ	Max	Unit	Test Condition
Collector-Emitter Breakdown Voltage	BV _{CEO}	40	—	—	V	I _C = 1mA
GND (Enable) Current	I _{GND}	340	420	500	μA	V _S = 10V; V _{OUT} = Open
GND (Enable) Current	I _{GND}	—	380	—	μA	V _S = 10V; V _{OUT} = 8.6V
DC Current Gain	h _{FE}	100	220	470	—	I _C = 50mA; V _{CE} = 1V
Internal Resistor	R _{INT}	38	44	52	Ω	I _{RINT} = 20mA
Output Current (Nominal)	I _{OUT}	18	20	22	mA	V _{OUT} = 8.6V; V _S = 10V
Output Current	I _{OUT}	25	28	31	mA	V _S = 12V; R _{ext} = 95Ω
		31	35	39	mA	V _S = 12V; R _{ext} = 53Ω
		57	63	69	mA	V _S = 10V; R _{ext} = 17Ω
Voltage Drop (V _{REXT})	V _{DROP}	—	0.88	—	V	I _{OUT} = 20mA
Lowest Sufficient Supply Voltage (V _S -V _{OUT})	V _{SMIN}	—	1.4	—	V	I _{OUT} > 18mA
Output Current Change vs. Temperature	ΔI _{OUT} /I _{OUT}	—	-0.25	—	%/°C	V _S = 10V
Output Current Change vs. Supply Voltage	ΔI _{OUT} /I _{OUT}	—	1	—	%/V	V _S = 10V

Typical Thermal Characteristics (@ $T_A = +25^\circ\text{C}$, unless otherwise specified.)

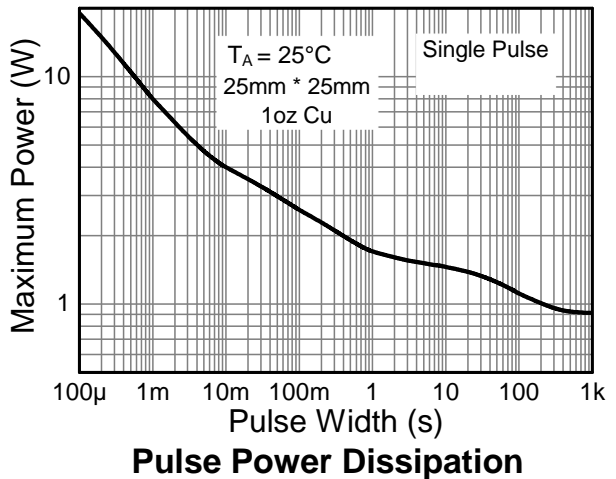
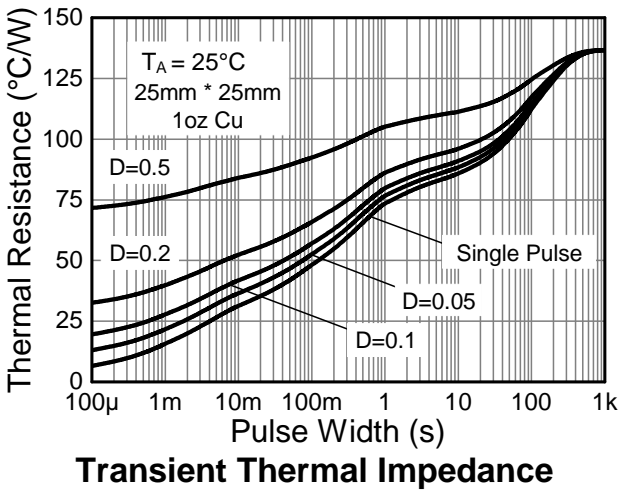
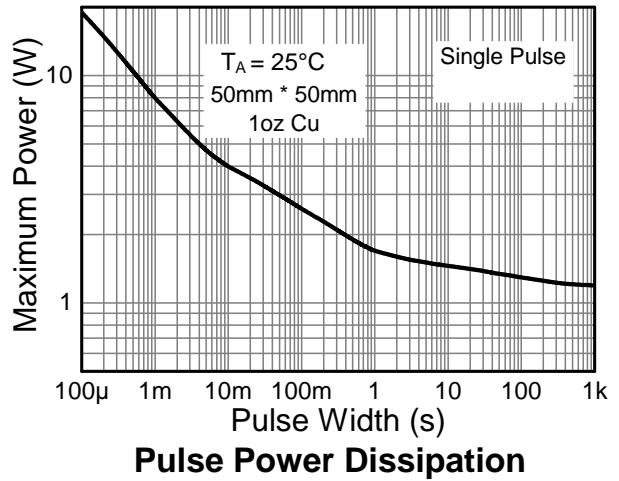
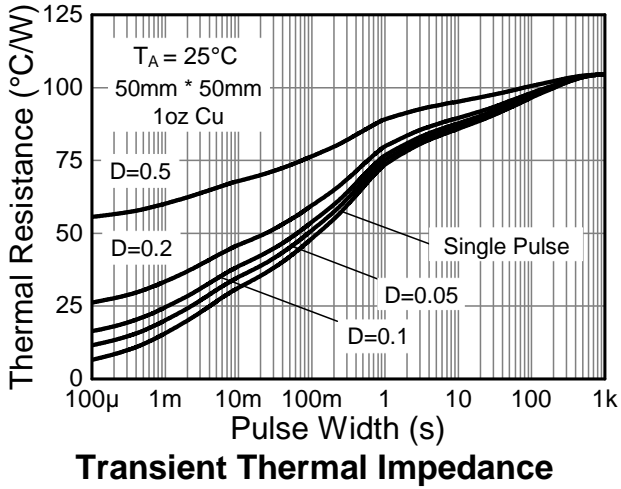
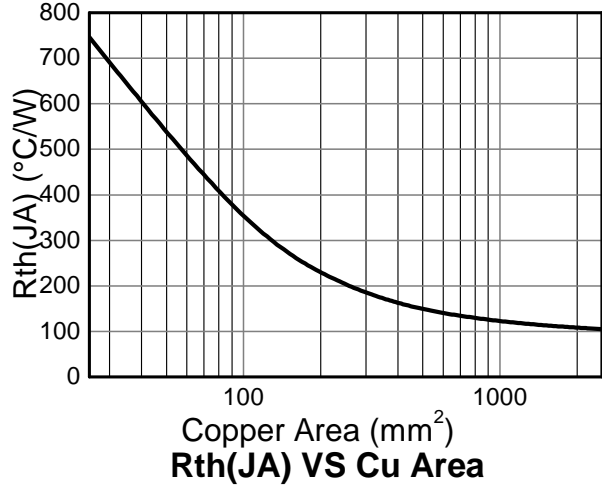
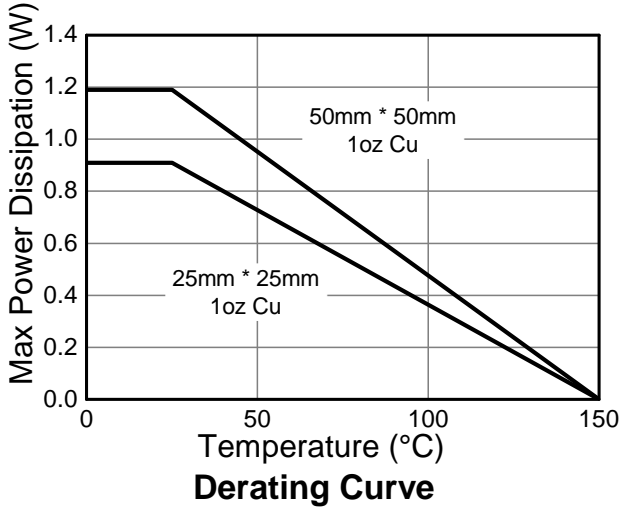

Typical Electrical Characteristics ((Cont.)) (@ $T_A = +25^\circ\text{C}$, unless otherwise specified.)

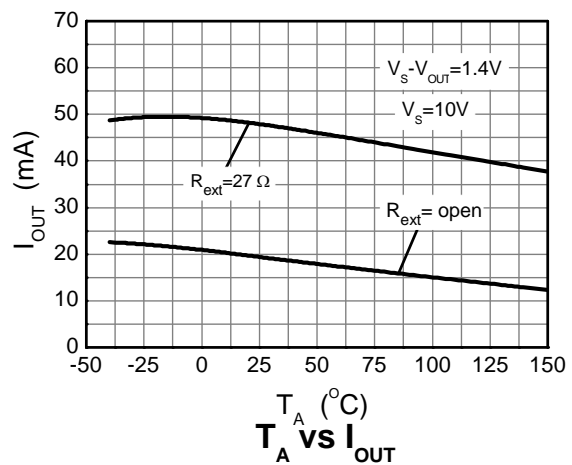
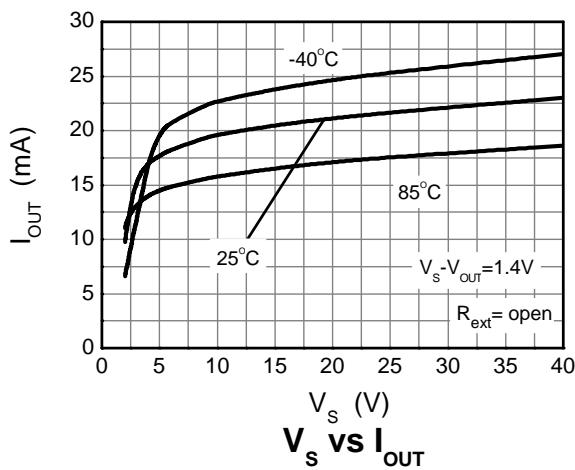
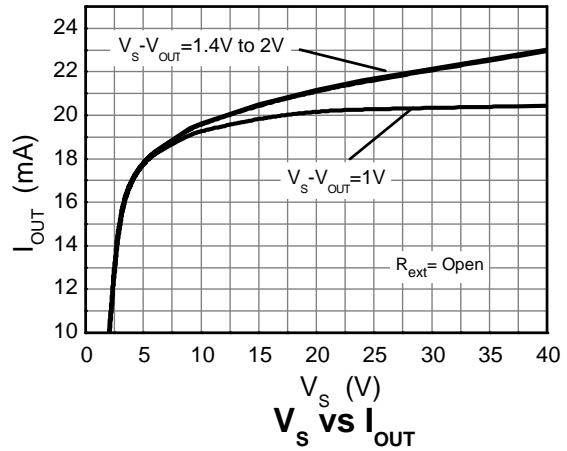
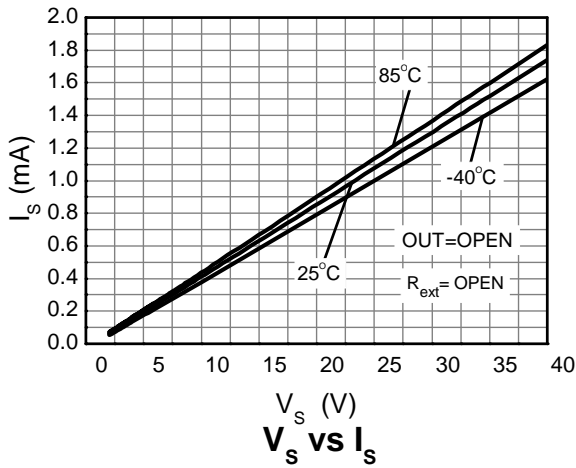
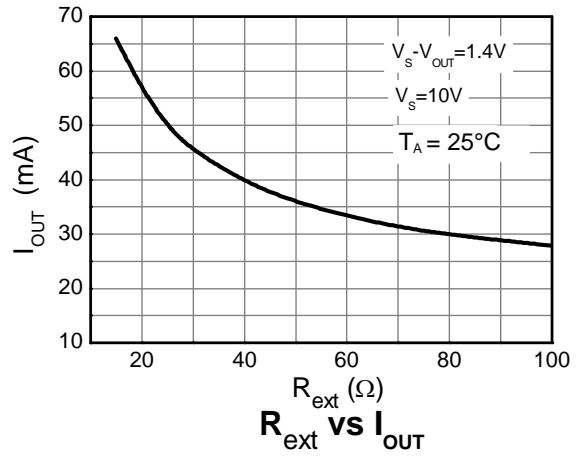
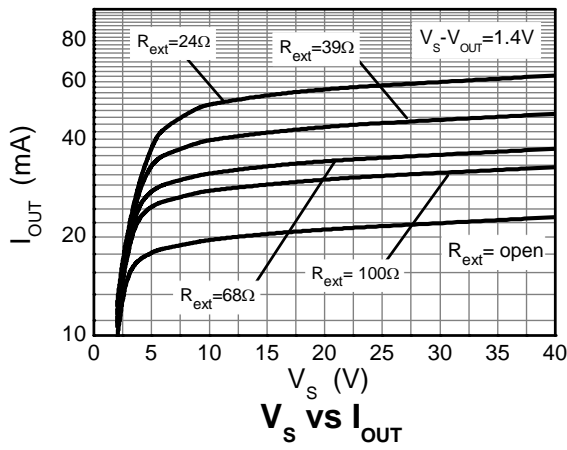

Application Information

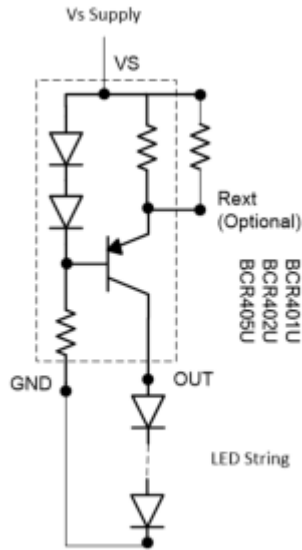

Figure 1 Typical Application Circuit for BCR40x LED Driver

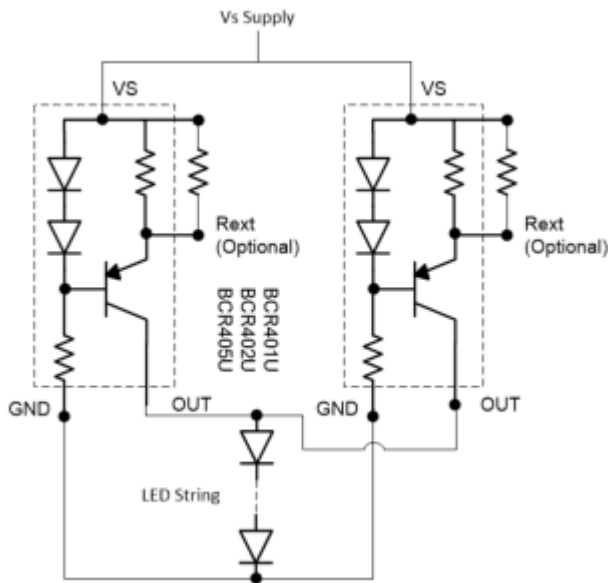

Figure 2 Application Circuit for Increasing LED Current

The BCR401/2/5 are designed for driving low current LEDs with typical LED currents of 10mA to 100mA. They provide a cost-effective way for driving low current LEDs compared with more complex switching regulator solutions. Furthermore, they reduce the PCB board area of the solution as there is no need for external components like inductors, capacitors and switching diodes.

Figure 1 shows a typical application circuit diagram for driving an LED or string of LEDs. The devices come with an internal resistor (R_{INT}) of typically 91Ω, 20Ω or 16.5Ω which in the absence of an external resistor sets an LED current of 10mA, 20mA, 50mA respectively. LED current can be increased to a desired value by choosing an appropriate external resistor, R_{EXT} .

The R_{EXT} vs. I_{OUT} graphs should be used to select the appropriate resistor. Choosing a low tolerance R_{EXT} will improve the overall accuracy of the current sense formed by the parallel connection of R_{INT} and R_{EXT} .

The negative temperature coefficient of the BCR series allows easy paralleling of BCR401/2/5s. In applications where current sharing is required either due to high current requirements of LED strings or for power sharing, two or more BCR401/2/5s can be connected in parallel as shown in Figure 2. Power dissipation capability must be factored into the design, with respect to the BCR401/2/5's thermal resistance. The maximum voltage across the device can be calculated by taking the maximum supply voltage and subtracting the voltage across the LED string.

$$V_{DEVICE} = V_S - V_{OUT}$$

$$P_D = (V_{DEVICE} \times I_{LED}) + (V_S \times I_{GND})$$

As the output current of BCR401/2/5 increases, it is necessary to connect an appropriate heat sink to the OUT pins of the device. The power dissipation supported by the device is dependent upon the PCB board material, the copper area and the ambient temperature. The maximum dissipation the device can handle is given by:

$$P_D = (T_{J(MAX)} - T_A) / R_{\theta JA}$$

Refer to the thermal characteristic graphs in datasheet for selecting the appropriate PCB copper area.

Application Information (Cont.)

PWM is the most pursued method for LED dimming. In the PWM method, dimming is achieved by turning the LEDs ON and OFF for a portion of a single cycle. PWM dimming can be achieved by enabling/disabling the LED driver itself (refer to Figure 3a, 3b) or by the switching the power path on and off (refer to Figure 3c). The PWM signal can be provided by a micro-controller or analog circuitry; typical circuits are shown in Figure 3. Figure 4 is a typical response of LED current vs. PWM duty cycle; PWM method showed in Figure 3b is used for generating the graphs.

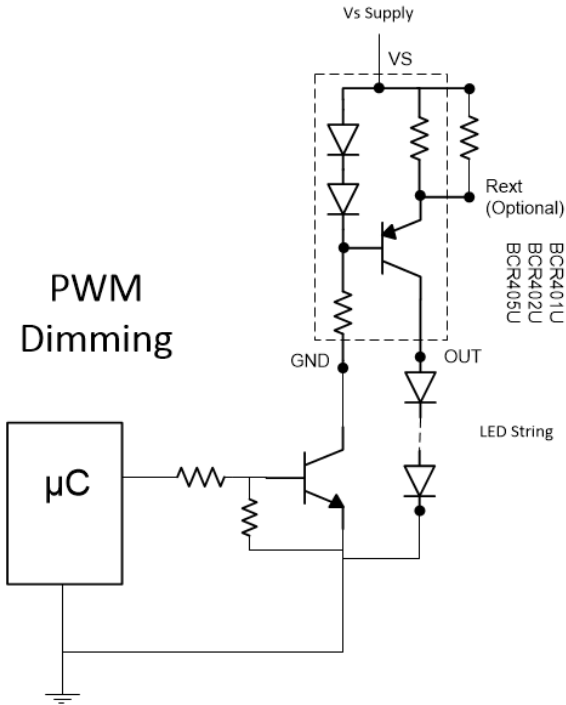

Figure 3a

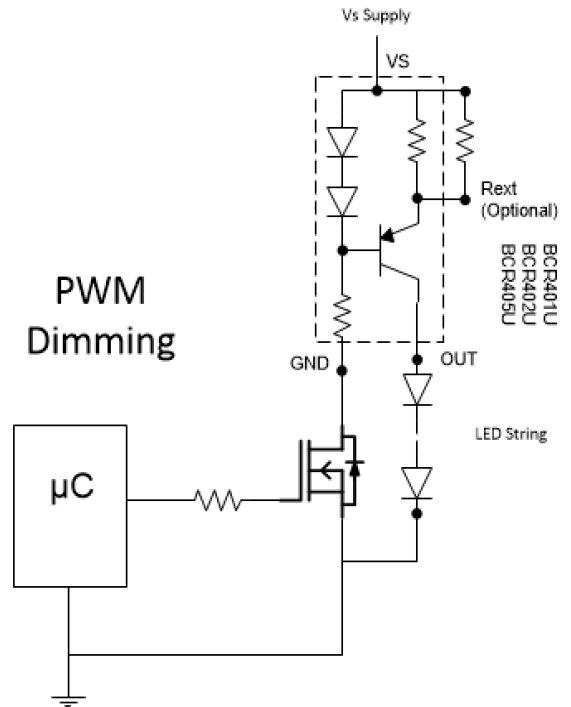

Figure 3b

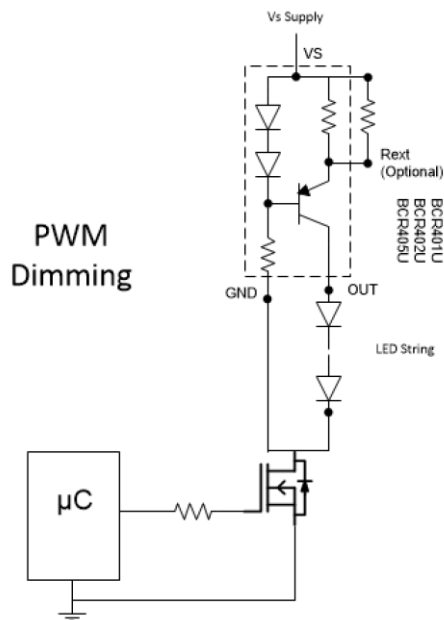
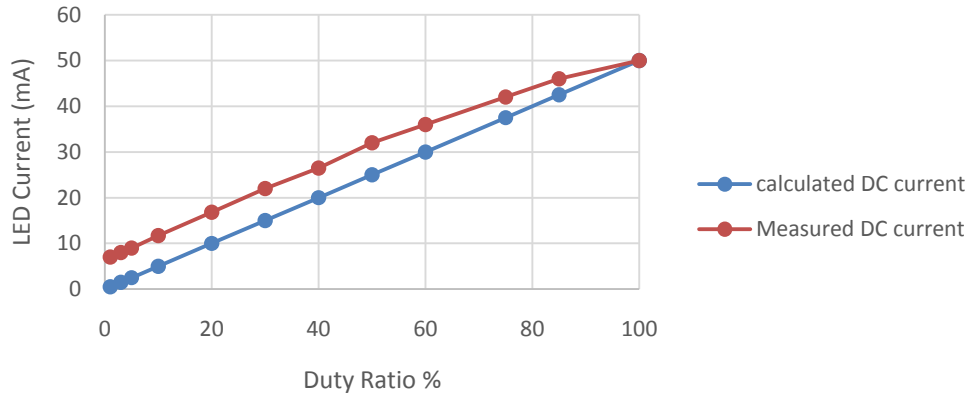

Figure 3c

Figure: 3a, 3b & 3c Application Circuits for LED Driver with PWM Dimming Functionality

Application Information (Cont.)

PWM Resolution at 25kHz



PWM Resolution at 10kHz

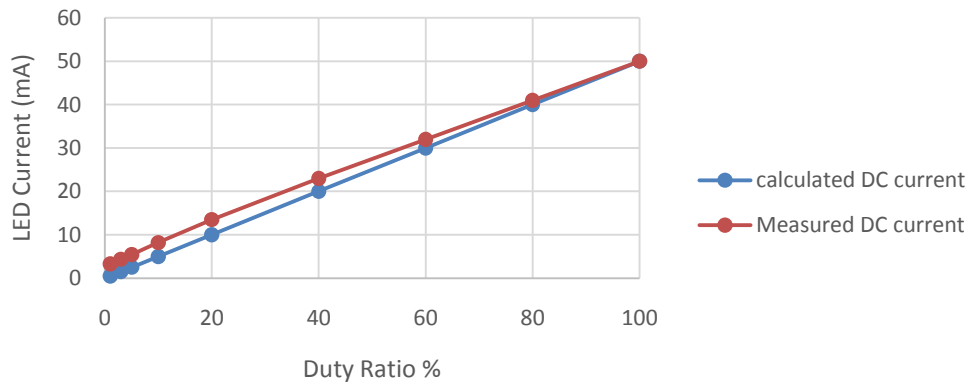

PWM Resolution at 1kHz

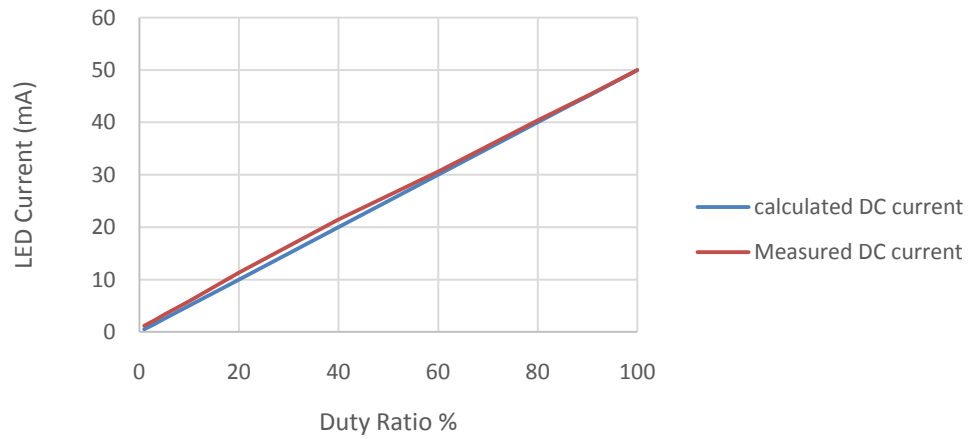

Figure 4 Typical LED Current Response vs. PWM Duty Cycle for 25kHz, 10kHz and 1kHz PWM Frequency (Refer to Figure 3b)

Application Information (Cont.)

The error between the calculated theoretical value and the measured value is due to the turn on and turn off times of the BCR401/2/5. There will be a small contribution from the switches (a pre-biased transistor or a MOSFET) shown in Figure 3a and 3b towards the total turn on and turn off times of the BCR401/2/5. It is recommended to keep the external switching delays to the lowest possible value to improve PWM accuracy. The typical switching times of the BCR401/2/5 for the configuration shown in Figure 3b are;

Turn-On Time = 200ns
Turn-Off Time = 10µs

Please refer to the Figure 5 and 6 for the switching time performance. The percentage contribution of these switching delays increases with increasing frequency and decreasing duty ratio as can be seen in Figure 4.

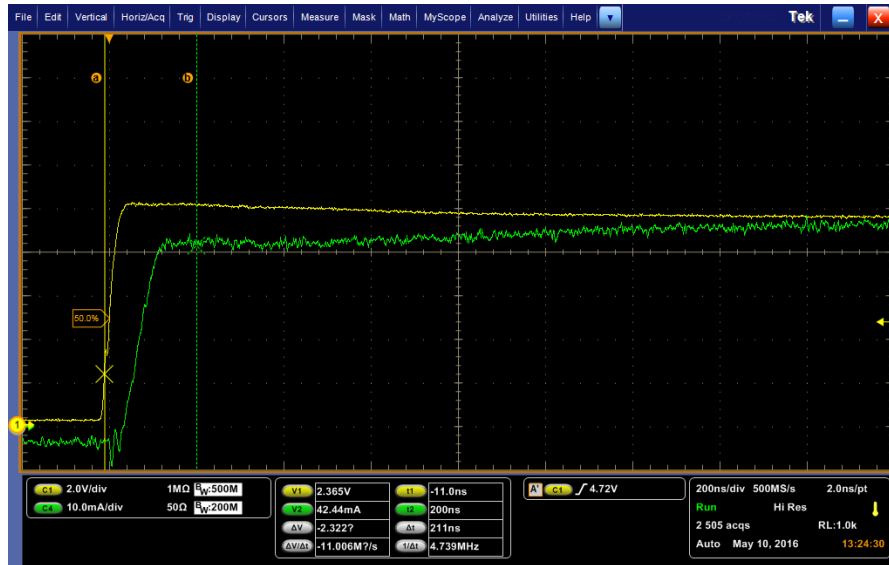

Figure 5 Turn-On Time of BCR401/2/5 (PWM Method Shown in Figure 3b)



Figure 6 Turn-On Time of BCR401/2/5 (PWM Method Shown in Figure 3c)

However, where possible, the switching performance of the BCR401/2/5 can be significantly improved by switching the power path as shown in Figure 3c. The resulting turn-off time is shown in Figure 7. This resulted in an improved PWM resolution at 25kHz as shown in Figure 8.

Turn-Off Time = ~200ns

Application Information (Cont.)

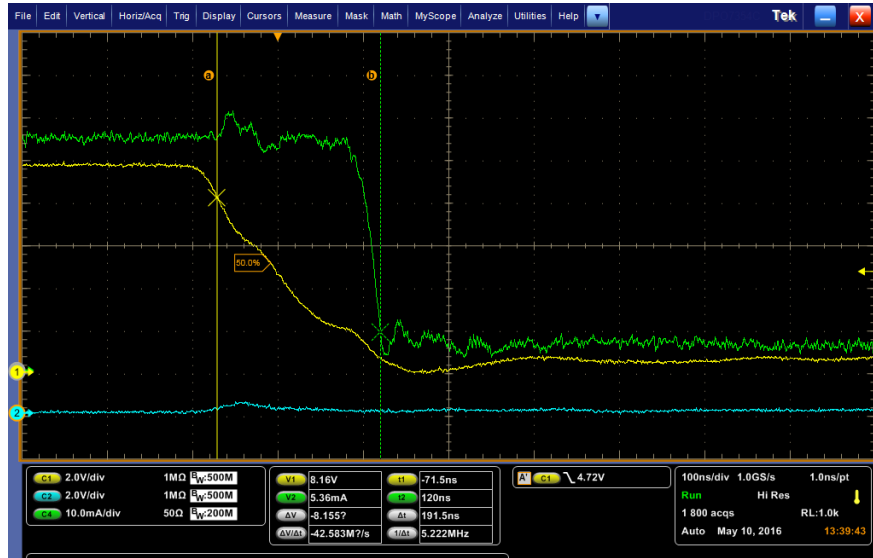

Figure 7 Turn-Off Time of BCR401/2/5 while Switching the Power Path as Shown in Figure 3c

Yellow → PWM Signal
 Green → LED Current
 Blue → No Connection Made to this Probe Channel



Figure 8 PWM Resolution with Power Path Switching (Refer to Figure 3c)

Application Information (Cont.)

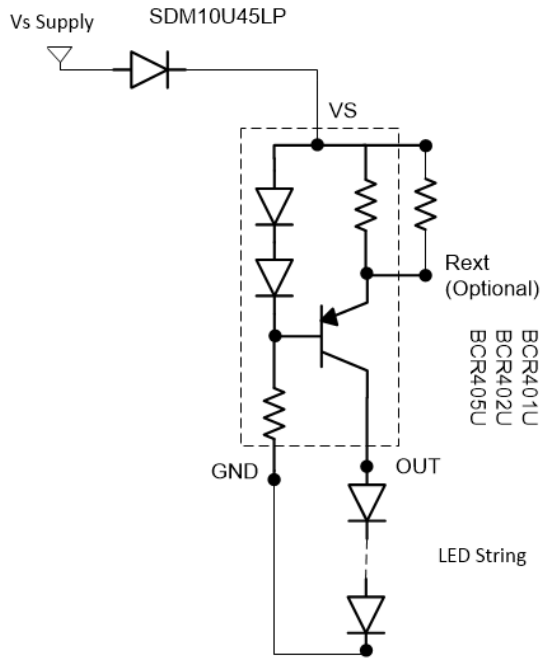

Figure 9 Application Circuit for LED Driver with Reverse Polarity Protection

To remove the potential of incorrect connection of the power supply damaging the lamp's LEDs, many systems use some form of reverse polarity protection.

One solution for reverse input polarity protection is to simply use a diode with a low V_F in line with the driver/LED combination. The low V_F increases the available voltage to the LED stack and dissipates less power. A circuit example is presented in Figure 9 which protects the light engine although it will not function until the problem is diagnosed and corrected. An SDM10U45LP (0.1A/45V) is shown, providing exceptionally low V_F for its package size of 1mm x 0.6mm. Other reverse voltage ratings are available from Diodes Incorporated's website such as the SBR02U100LP (0.2A/100V) or SBR0220LP (0.2A/20V).

While automotive applications commonly use this method for reverse battery protection, an alternative approach shown in Figure 10, provides reverse polarity protection and corrects the reversed polarity, allowing the light engine to function.

The BAS40BRW incorporates four low V_F Schottky diodes in a single package, reducing the power dissipated and maximizes the voltage across the LED stack.

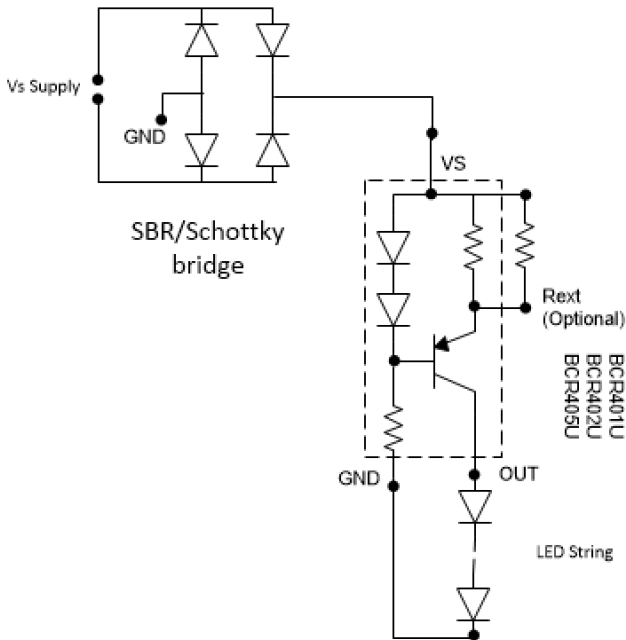
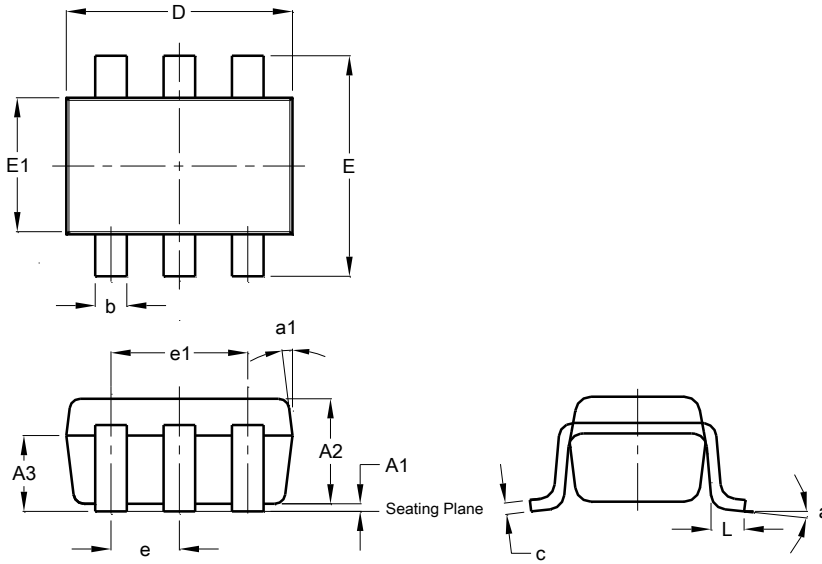

Figure 10 Application Circuit for LED Driver with Assured Operation Regardless of Polarity

Package Outline Dimensions

Please see <http://www.diodes.com/package-outlines.html> for the latest version.

SOT26 (SC74R)



SOT26 (SC74R)			
Dim	Min	Max	Typ
A1	0.013	0.10	0.05
A2	1.00	1.30	1.10
A3	0.70	0.80	0.75
b	0.35	0.50	0.38
c	0.10	0.20	0.15
D	2.90	3.10	3.00
e	-	-	0.95
e1	-	-	1.90
E	2.70	3.00	2.80
E1	1.50	1.70	1.60
L	0.35	0.55	0.40
a	-	-	8°
a1	-	-	7°
All Dimensions in mm			

Suggested Pad Layout

Please see <http://www.diodes.com/package-outlines.html> for the latest version.

SOT26 (SC74R)

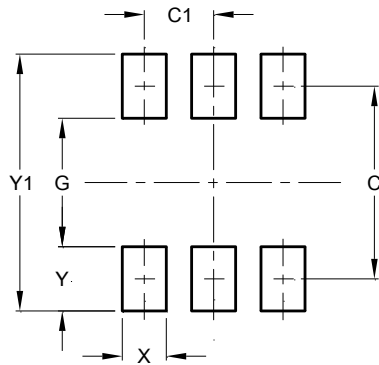

Dimensions	Value (in mm)
C	2.40
C1	0.95
G	1.60
X	0.55
Y	0.80
Y1	3.20

IMPORTANT NOTICE

DIODES INCORPORATED MAKES NO WARRANTY OF ANY KIND, EXPRESS OR IMPLIED, WITH REGARDS TO THIS DOCUMENT, INCLUDING, BUT NOT LIMITED TO, THE IMPLIED WARRANTIES OF MERCHANTABILITY AND FITNESS FOR A PARTICULAR PURPOSE (AND THEIR EQUIVALENTS UNDER THE LAWS OF ANY JURISDICTION).

Diodes Incorporated and its subsidiaries reserve the right to make modifications, enhancements, improvements, corrections or other changes without further notice to this document and any product described herein. Diodes Incorporated does not assume any liability arising out of the application or use of this document or any product described herein; neither does Diodes Incorporated convey any license under its patent or trademark rights, nor the rights of others. Any Customer or user of this document or products described herein in such applications shall assume all risks of such use and will agree to hold Diodes Incorporated and all the companies whose products are represented on Diodes Incorporated website, harmless against all damages.

Diodes Incorporated does not warrant or accept any liability whatsoever in respect of any products purchased through unauthorized sales channel. Should Customers purchase or use Diodes Incorporated products for any unintended or unauthorized application, Customers shall indemnify and hold Diodes Incorporated and its representatives harmless against all claims, damages, expenses, and attorney fees arising out of, directly or indirectly, any claim of personal injury or death associated with such unintended or unauthorized application.

Products described herein may be covered by one or more United States, international or foreign patents pending. Product names and markings noted herein may also be covered by one or more United States, international or foreign trademarks.

This document is written in English but may be translated into multiple languages for reference. Only the English version of this document is the final and determinative format released by Diodes Incorporated.

LIFE SUPPORT

Diodes Incorporated products are specifically not authorized for use as critical components in life support devices or systems without the express written approval of the Chief Executive Officer of Diodes Incorporated. As used herein:

A. Life support devices or systems are devices or systems which:

1. are intended to implant into the body, or
2. support or sustain life and whose failure to perform when properly used in accordance with instructions for use provided in the labeling can be reasonably expected to result in significant injury to the user.

B. A critical component is any component in a life support device or system whose failure to perform can be reasonably expected to cause the failure of the life support device or to affect its safety or effectiveness.

Customers represent that they have all necessary expertise in the safety and regulatory ramifications of their life support devices or systems, and acknowledge and agree that they are solely responsible for all legal, regulatory and safety-related requirements concerning their products and any use of Diodes Incorporated products in such safety-critical, life support devices or systems, notwithstanding any devices- or systems-related information or support that may be provided by Diodes Incorporated. Further, Customers must fully indemnify Diodes Incorporated and its representatives against any damages arising out of the use of Diodes Incorporated products in such safety-critical, life support devices or systems.

Copyright © 2018, Diodes Incorporated

www.diodes.com