

BCT3752

Small Package, High Performance, Asynchronous Boost for 8 Series WLED Driver

Features

- 3.0V to 5.5V Input Voltage Range
- Internal Power N-MOSFET Switch
- Wide Range for PWM Dimming(10kHz to 100kHz)
- Dimming Stable in 1:250 Range
- Minimize the External Component Counts
- Internal Soft Start
- Internal Compensation
- Small TSOT-23-6 Packages
- RoHS Compliant and 100% Lead Free

Description

The BCT3752 is a high frequency, asynchronous boost converter. The internal MOSFET can support up to 8 White LEDs for backlighting and OLED power application, and the internal soft start function can reduce the inrush current. The device operates with 600kHz fixed switching frequency to allow small external components and to simplify possible EMI problems. For the protection, the BCT3752 provides up to 40V OVP to allow inexpensive and small-output capacitors with lower voltage ratings. The LED current is initially set with the external sense resistor RSET. The BCT3752 is available in TSOT-23-6 packages to save PCB space.

Applications

Cellular Phones
 Digital Cameras
 PDAs, Smart Phones, MP3 and OLED
 Portable Instruments

Pin Configurations (Top View)

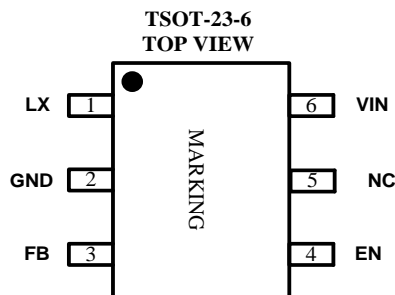

Ordering Information

Part	Pin-Package	Temp-Range	Top Mark	Supplied as:
BCT3752EBT-TR	TSOT23-6	-40°C to +85°C	G7CXX	3000units/Tape & Reel

Note: XX is data code

Typical Application Circuit

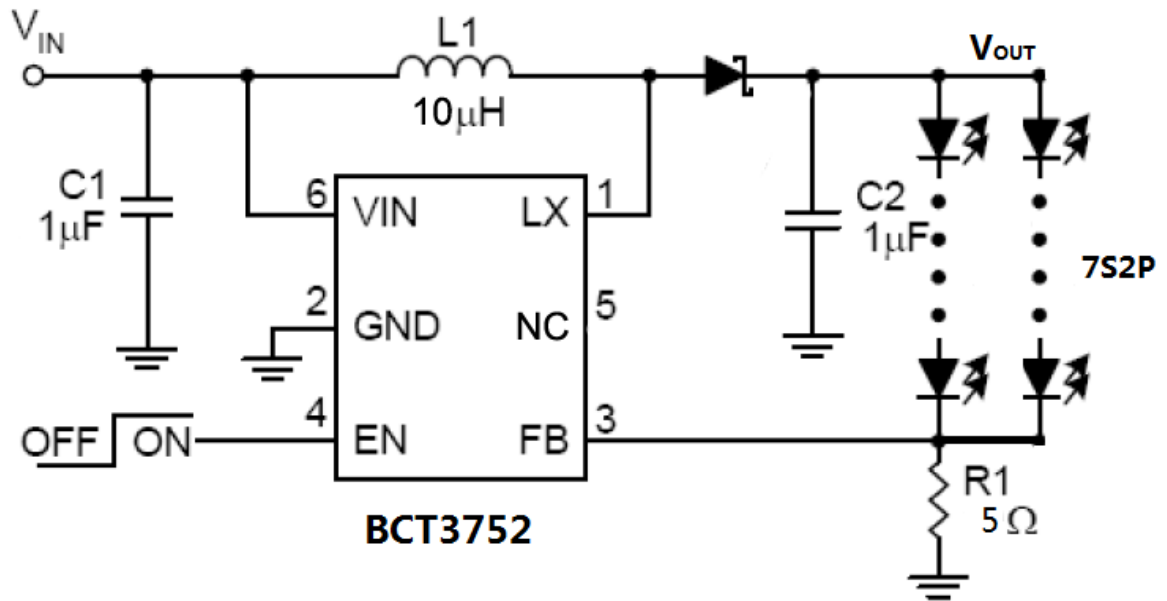

Pin Description

NO.	NAME	I/O	DESCRIPTION
1	LX	I	Switching Pin.
2	GND	G	Ground Pin.
3	FB	I	Feedback Pin, Connect the sense resistor from FB to GND.
4	EN	I	Chip Enable (Active High).
5	NC	-	No Connect
6	VIN	I	Input Supply .

Absolute Maximum Ratings⁽¹⁾

Symbol	Description	Value	Unit
V _{IN}	Supply Voltages on VIN ⁽²⁾	-0.3 to 6	V
V _{LX}	Voltage on LX ⁽²⁾	-0.3 to 40	V
V _{OUT}	Voltage on VOUT	-0.3 to 36	V
	Other Pins	-0.3 to 6	V
P _D	Continuous Power Dissipation	0.392	W
θ _{JA}	Package Thermal Resistance	255	°C/W
T _J	Operating Junction Temperature Range	-40 to 150	°C
T _{STG}	Storage Temperature Range	-65 to 150	°C

(1) Stresses beyond those listed under absolute maximum ratings may cause permanent damage to the device. These are stress ratings only, and functional operation of the device at these or any other conditions beyond those indicated under recommended operating conditions is not implied. Exposure to absolute-maximum-rated conditions for extended periods may affect device reliability.

(2) All voltage values are with respect to network ground terminal.

Ver 1.5

Function Block Diagram

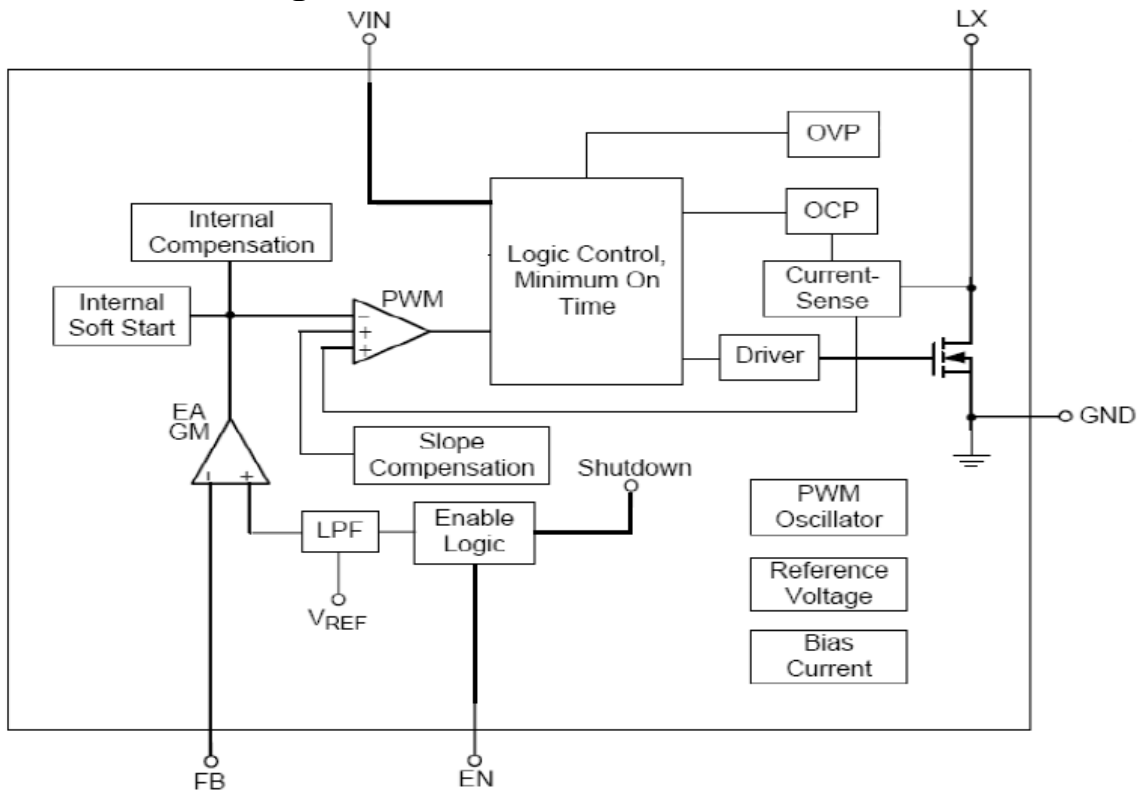

Ver 1.5

Electrical Characteristics

 $V_{IN} = 3.7\text{ V}$, $C_{IN} = 1\mu\text{F}$, $C_{OUT} = 1\mu\text{F}$, $I_{OUT} = 40\text{mA}$, $L = 10\mu\text{H}$, $T_A = 25^\circ\text{C}$, unless otherwise noted)

Parameter	Symbol	Test Condition	Min	Typ	Max	Units
Input Voltage	V_{IN}		3.0		5.5	V
Supply Current	I_{IN}	FB=0, Switching		0.5	1	mA
Shutdown Current	I_{SHDN}	$V_{EN} < 0.4\text{V}$		1	4	μA
Line Regulation		$V_{IN} = 3\text{ to }4.3\text{V}$		± 1		%
Operation Frequency	f_{OSC}		480	600	720	kHz
Maximum Duty Cycle			90	92		%
PWM Input Frequency Range	f_{PWM}		10		100	kHz
Feedback Reference Voltage	V_{REF}		190	200	210	mV
Internal NMOS "on" resistance	$R_{DS(ON)N}$	$T_A = 25^\circ\text{C}$		0.5	1	Ω
Logic threshold: Low	V_{IL}	EN pin			0.5	V
Logic threshold: High	V_{IH}	EN pin	1.4			V
EN Hysteresis				0.1		V
EN Sink Current	I_{IH}	$V_{EN} = 2\text{V}$		5		μA
Over-Voltage Threshold	V_{OVP}			40		V
Over-Current Threshold	I_{OCP}			1.5		A
Shutdown Delay	T_{SHDN}			0.2		ms

Detailed Description

Operation

The BCT3752 are high-efficiency, high-output voltage boost converters in a small package size. These devices are ideal for driving white LED in series. The serial LED connection provides even illumination by sourcing the same output current through all LEDs, eliminating the need for expensive factory calibration. Each device integrate a 40V, 1.5A switch FET and operates in pulse width modulation (PWM) with 600kHz fixed switching frequency. For operation see the block diagram. The duty cycle of the converter is set by the error amplifier output and the current signal applied to the PWM control comparator. The control architecture is based on traditional current-mode control; therefore, a slope compensation is added to the current signal to allow stable operation for duty cycles larger than 50%. The feedback loop regulates the FB pin to a low reference voltage (200 mV typical), reducing the power dissipation in the current sense resistor.

LED Current Setting

The loop of Boost structure will keep the FB pin voltage equal to the reference voltage V_{REF} . Therefore, when R_{SET} connects FB pin and GND, the current flows from VOUT through LED and R_{SET} to GND will be decided by the current on R_{SET} , which is equal to following equation:

$$I_{LED} = V_{FB} / R_{SET} \quad (1)$$

PWM Brightness Dimming

For the brightness dimming control of the BCT3752, the IC provides typically 200mV feedback voltage when the EN pin is pulled constantly high. However, EN pin allows a PWM signal to reduce this regulation voltage by changing the PWM duty cycle to achieve LED brightness dimming control. The relationship between the duty cycle and FB voltage can be calculated as following equation :

$$V_{FB} = \text{Duty} \times 200\text{mV} \quad (2)$$

Where

Duty = duty cycle of the PWM signal

200mV = internal reference voltage

As shown in Figure 1, the duty cycle of the PWM signal is used to cut the internal 200mV reference voltage. An internal low pass filter is used to filter the pulse signal. And then the reference voltage can be made by connecting the output of the filter to the error amplifier for the FB pin voltage regulation.

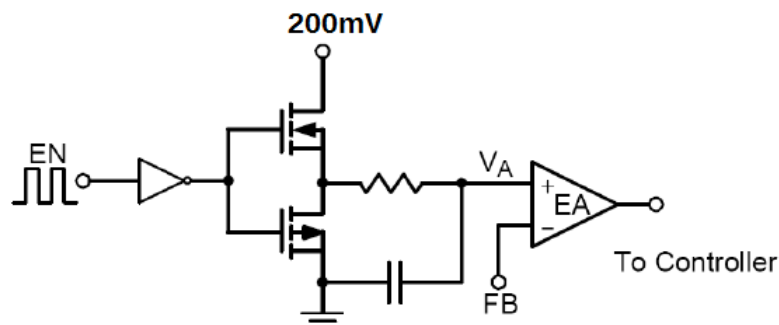

Figure 1. Block Diagram of Programmable FB Voltage Using PWM Signal

Ver 1.5

PWM Dimming from EN are shown in Typical Operating Characteristics section and the PWM dimming frequency is from 10kHz to 100kHz respectively. But there is an offset in error amplifier which will cause the V_A variation. For the BCT3752, the PWM dimming minimum duty cycle changes with the PWM dimming frequency.

Table 1. Dimming frequency and minimum duty cycle

Dimming Frequency	Minimum Duty(VIN=3V)	Minimum Duty(VIN=4.5V)
10K	0.15%	0.1%
20K	0.3%	0.2%
40K	0.5%	0.4%
80K	1%	0.7%
100K	1.3%	0.9%

Application for driving more string WLEDs

The BCT3752 can drive different WLEDs topology. For example, the Figure 2 shows the 2x7 WLEDs and total current is equal to 40mA. The total WLEDs current can be set by the R_{SET} which is equal to following equation:

$$I_{Total} = V_{REF}/R_{SET} \quad (3)$$

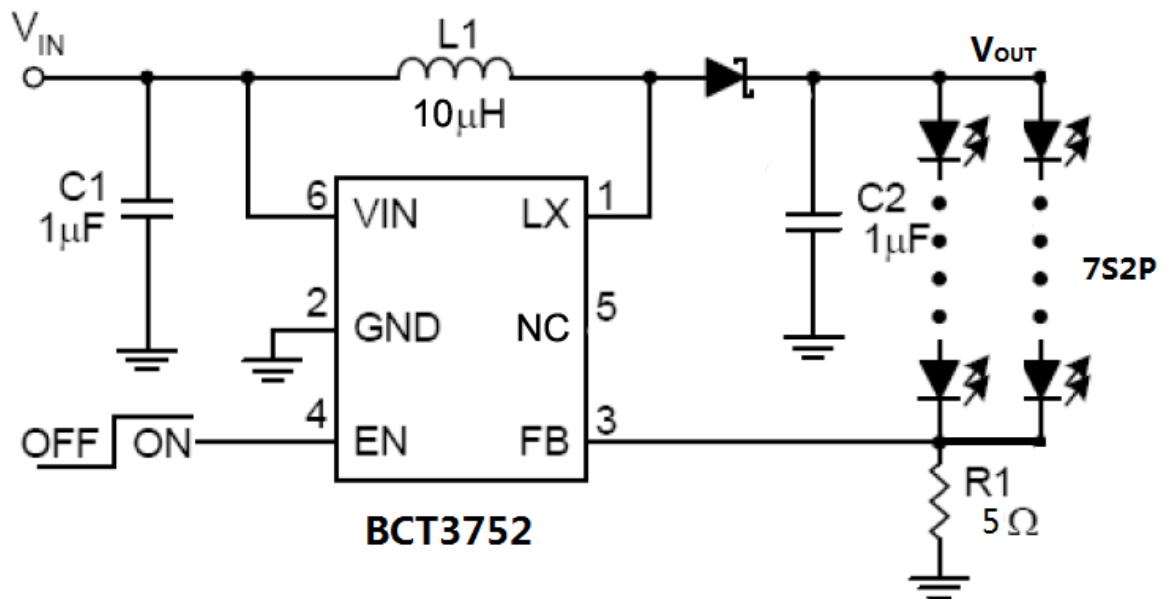

Figure 2. Application for Driving 2 X 7 WLEDs

Power Sequence

In order to assure the normal soft start function for suppressing the inrush current, the input voltage should be ready before EN pulls high.

Soft-Start

The function of soft-start is made for suppressing the inrush current to an acceptable value at the beginning of power on. The BCT3752 provides a built-in soft-start function by clamping the output

Ver 1.5

voltage of error amplifier so that the duty cycle of the PWM will be increased gradually in the soft-start period.

Current Limiting

The current flow through inductor as charging period is detected by a current sensing circuit. As the value comes across the current limiting threshold, the N-MOSFET will be turned off so that the inductor will be forced to leave charging stage and enter discharging stage. Therefore, the inductor current will not increase over the current limiting threshold.

Application Information

External component and layout are critical and should be considered carefully.

Inductor Selection

The recommended value of inductor for 8 WLEDs applications is from 10 μ H to 47 μ H. Small size and better efficiency are the major concerns for portable devices, such as the BCT3752 used for mobile phone. The inductor should have low core loss at 1MHz and low DCR for better efficiency. The inductor saturation current rating should be considered to cover the inductor peak current.

Schottky Diode Selection

The high switching frequency of the BCT3752 demands a high-speed rectification for optimum efficiency. Ensure that the diode average and peak current rating exceeds the average output current and peak inductor current. In addition, the diode's reverse breakdown voltage must exceed the open LED protection voltage. To achieve better efficiency, a low VF Schottky diode is recommended.

Capacitor Selection

Input ceramic capacitor of 1 μ F and output ceramic capacitor of 1 μ F are recommended for the BCT3752 applications for driving 8 series WLEDs. For better voltage filtering, ceramic capacitors with low ESR are recommended. X5R and X7R types are suitable because of their wider voltage and temperature ranges.

Thermal Considerations

For continuous operation, do not exceed absolute maximum operation junction temperature. The maximum power dissipation depends on the thermal resistance of IC package, PCB layout, the rate of surroundings airflow and temperature difference between junction to ambient. The maximum power dissipation can be calculated by following formula:

$$P_{D(MAX)} = (T_{J(MAX)} - T_A) / \theta_{JA} \quad (4)$$

Where $T_{J(MAX)}$ is the maximum operation junction temperature, T_A is the ambient temperature and the θ_{JA} is the junction to ambient thermal resistance. For the recommended operating conditions specification of BCT3752, the maximum junction temperature of the die is 125°C. The junction to ambient thermal resistance θ_{JA} is layout dependent. The junction to ambient thermal resistance for TSOT-23-6 package is 255°C/W on the standard JEDEC 51-3 single layer thermal test board. The maximum power dissipation at $T_A = 25^\circ\text{C}$ can be calculated by following formula:

Ver 1.5

$P_{D(MAX)} = (125^{\circ}\text{C} - 25^{\circ}\text{C}) / (255^{\circ}\text{C/W}) = 0.392\text{W}$ for TSOT-23-6 packages.

Table 2. Recommended Components for Typical Application Circuit

Reference	Qty	Part Number	Description	Manufacture
D	1	SR26	Schottky Diode	PANJIT
CIN	1	EMK107BJ105MA-T	Capacitor, Ceramic, 1uF/16V X5R	Taiyo Yuden
COUT	1	GMK107BJ105KA-T	Capacitor, Ceramic, 1uF/35V X5R	Taiyo Yuden
RSET	1	RC0603FR	Resistor, 1%	YAGEO
L	1	NR4018T100M	Inductor, 10uH	Taiyo Yuden

PCB Layout Consideration

For best performance of the BCT3752, the following guidelines must be followed.

1. Input /Output capacitors should be placed close to the IC and connected to ground to reduce noise coupling.
2. The loop including the PWM switch, Schottky diode, and output capacitor, contains high current rising and falling in nanosecond and should be kept as short as possible.
3. Vin will be connected with Vbattery with wide track, to avoid the interference of RF PA and Audio PA.

Package Outline Dimensions

TSOT23-6

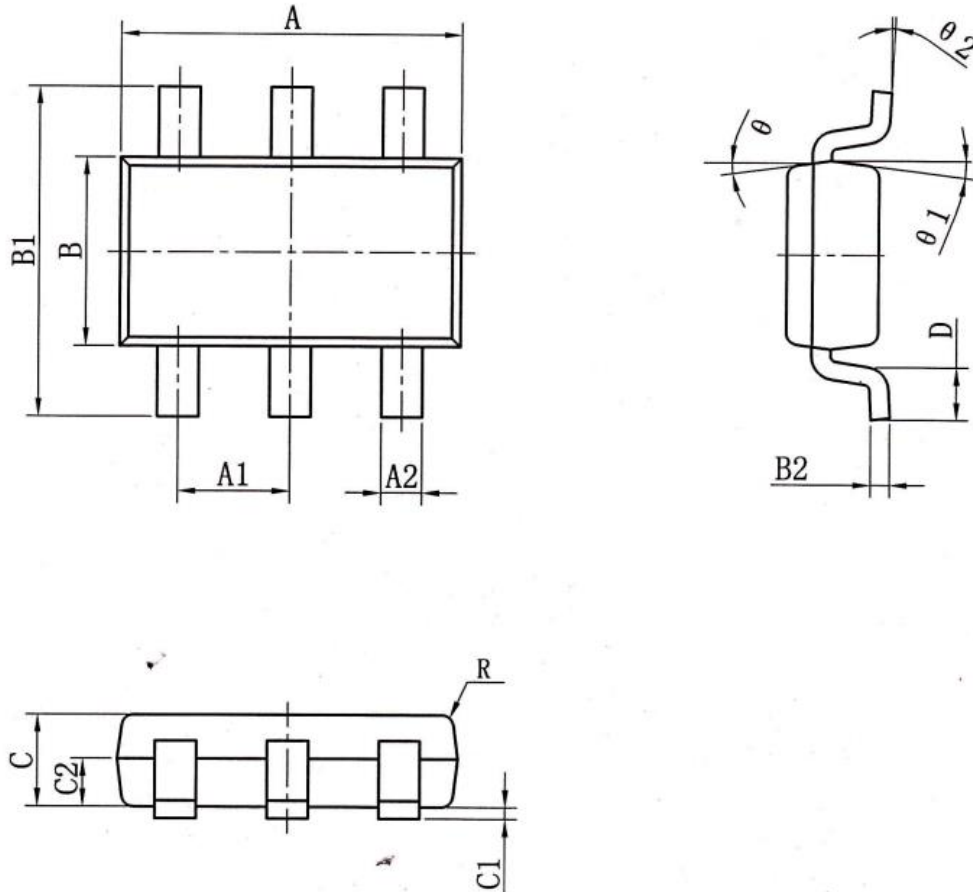

Symbols	Dimensions in millimeters	
	Min.	Max.
A	2.820	3.020
A1	0.95 0(BSC)	
A2	0.350	0.500
B	1.600	1.700
B1	2.650	2.950
B2	0.080	0.200
C	0.700	0.800
C1	0.020	0.130
C2	0.378	0.438
L	0.300	0.600
e	9°	
e1	10°	
e2	0~8°	

TSOT23-6 Surface Mount Package