

BCT4717

4.0Ω, 300MHz Bandwidth, Dual SPDT Analog Switch

GENERAL DESCRIPTION

The BCT4717 is a dual, bidirectional, single-pole/double-throw (SPDT) CMOS analog switches designed to operate from a single +1.8V to +5.5V supply. It features high-bandwidth (300MHz) and low ON-resistance (4.0Ω typ), Targeted applications for audio switching.

BCT4717 features guaranteed on-resistance matching (0.3Ω max) between switches and guaranteed on-resistance flatness over the signal range (2.3Ω TYP). This ensures excellent linearity and low distortion when switching audio signals.

The BCT4717 is a committed dual single-pole/double-throw (SPDT) that consist of two normally open (NO) and two normally close (NC) switches. This configuration can be used as a dual 2-to-1 multiplexer.

BCT4717 is available in WQFN-10 package.

APPLICATIONS

- Portable Instrumentation
- Battery-Operated Equipment
- Computer Peripherals
- Cell Phones
- PDA's
- MP3's

FUNCTION TABLE

LOGIC	NO	NC
0	OFF	ON
1	ON	OFF

Switches Shown For Logic "0" Input

FEATURES

- Voltage Operation : 1.8 V to 5.5 V
- On-Resistance: 4.0Ω (typ) at 5.0V
- High Bandwidth: 300 MHz
- Fast Switching Time
 t_{ON} 25 ns
 t_{OFF} 25 ns
- High Off-Isolation: 57dB at 10MHz
- Low Crosstalk: 99dB at 10MHz
- Rail-to-Rail Operation
- TTL/CMOS Compatible
- Break-Before-Make Switching
- Extended Industrial Temperature Range:
 -40°C to 85°C
- WQFN-10 Packages

PIN CONFIGURATIONS (TOP VIEW)

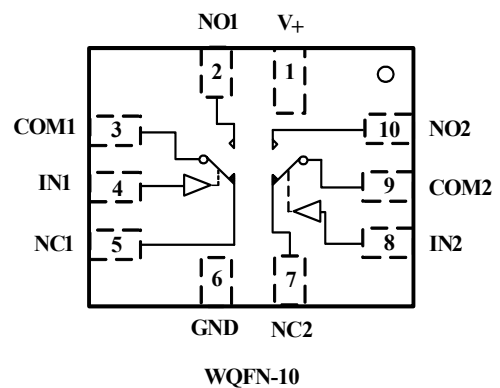

4.0Ω, 300MHz Bandwidth, Dual SPDT Analog Switch

ORDERING INFORMATION

MODEL	PIN-PACKAGE	SPECIFIED TEMPERATURE RANGE	ORDERING NUMBER	PACKAGE MARKING	PACKAGE OPTION
BCT4717ETB	WQFN-10	- 40°C to +85°C	BCT4717ETB	ALX	Tape and Reel, 3000

ABSOLUTE MAXIMUM RATINGS

V ₊ , IN to GND.....	- 0.3V to +6V	Junction Temperature.....+150°C
Analog, Digital voltage range(1).....	- 0.3V to (V ₊ + 0.3V)	to +150°C	
Continuous Current NO, NC, or COM.....	±200mA	Storage Temperature.....	- 65°C.....+260°C
Peak Current NO, NC, or COM.....	±300mA	Lead Temperature (soldering, 10s).....2000V
Operating Temperature Range.....	- 40°C to +85°C	ESD (HBM)	

Stresses beyond those listed under “Absolute Maximum Ratings” may cause permanent damage to the device. These are stress ratings only, and functional operation of the device at these or any other conditions beyond those indicated in the operational sections of the specifications is not implied. Exposure to absolute maximum rating conditions for extended periods may affect device reliability.

(1) Signals on NC, NO, or COM or IN exceeding V₊ will be clamped by internal diodes. Limit forward diode current to maximum current ratings.

PIN DESCRIPTION

NAME	FUNCTION
V ₊	Power supply
GND	ground
IN1, IN2	Digital control pin to connect the COM terminal to the NO or NC terminals
COM1, COM2	Common terminal
NO1, NO2	Normally-open terminal
NC1, NC2	Normally-closed terminal

Note: NO, NC and COM terminal may be an input or output.

4.0Ω, 300MHz Bandwidth, Dual SPDT Analog Switch

ELECTRICAL CHARACTERISTICS

($V_+ = +2.7V$ to $+3.6V$, $V_{IH} = +1.4V$, $V_{IL} = +0.5V$, $T_A = -40^\circ C$ to $+85^\circ C$, Typical values are at $V_+ = 3.0V$, $T_A = +25^\circ C$, unless otherwise noted.)

PARAMETER	SYMBOL	CONDITIONS	TEMP	MIN	TPY	MAX	UNITS
ANALOG SWITCH							
Analog Signal Range	V_{NO}, V_{NC}, V_{COM}		-40°C to +85°C	0		V_+	V
On-Resistance	R_{ON}	$V_+ = 2.7V, V_{NO}$ or $V_{NC} = 1.5V,$ $I_{COM} = -10$ mA, Test Circuit 1	+25°C		8	12	Ω
			-40°C to +85°C			11	Ω
On-Resistance Match Between Channels	ΔR_{ON}	$V_+ = 2.7V, V_{NO}$ or $V_{NC} = 1.5V,$ $I_{COM} = -10$ mA, Test Circuit 1	+25°C		0.3	0.6	Ω
			-40°C to +85°C			0.8	Ω
On-Resistance Flatness	$R_{FLAT(ON)}$	$V_+ = 2.7V, V_{NO}$ or $V_{NC} = 1.0V, 1.5V,$ $2.0V, I_{COM} = -10$ mA, Test Circuit 1	+25°C		3	4	Ω
			-40°C to +85°C		3.3		Ω
Source OFF Leakage current	$I_{NC(OFF)}, I_{NO(OFF)}$	$V_+ = 3.6V, V_{NO}$ or $V_{NC} = 0.3V, 3.3V,$ $V_{COM} = 0.3V, 3.3V,$	-40°C to +85°C			1	μA
Channel ON Leakage current	$I_{NC(ON)}, I_{NO(ON)},$ $I_{COM(ON)}$	$V_+ = 3.6V, V_{COM} = 0.3V, 3.3V,$ V_{NO} or $V_{NC} = 0.3V, 3.3V,$ or floating	-40°C to +85°C			1	μA
DIGITAL INPUTS							
Input High Voltage	V_{INH}		-40°C to +85°C	1			V
Input Low Voltage	V_{INL}		-40°C to +85°C			0.5	V
Input Leakage Current	I_{IN}	$V_+ = +3.6V, V_{IN} = 0$ or $5.5V$	-40°C to +85°C			1	μA
DYNAMIC CHARACTERISTICS							
Turn-On Time	t_{ON}	V_{NO} or $V_{NC} = 1.5V,$ $R_L = 300\Omega, C_L = 35pF,$ Test Circuit 2; $V_{IH} = 1.5V, V_{IL} = 0V$	+25°C		23		ns
Turn-Off Time	t_{OFF}	V_{NO} or $V_{NC} = 1.5V,$ $R_L = 300\Omega, C_L = 35pF,$ Test Circuit 2; $V_{IH} = 1.5V, V_{IL} = 0V$	+25°C		22		ns
Break-Before-Make Time Delay	t_d	V_{NO1} or $V_{NC1} = V_{NO2}$ or $V_{NC2} = 3V,$ $R_L = 300\Omega, C_L = 35pF,$ Test Circuit 3	+25°C		4		ns
Skew	t_{SKEW}	$R_S = 39\Omega, C_L = 50pF,$ Test Circuit 4	+25°C		5		ns
Off Isolation	O_{ISO}	$R_L = 50\Omega, C_L = 5pF,$ Signal = 0dBm, Test Circuit 5	f = 10MHz	+25°C		-57	dB
			f = 1MHz	+25°C		-76	dB
Channel-to-Channel Crosstalk	X_{TALK}	$R_L = 50\Omega, C_L = 5pF,$ Test Circuit 6	f = 10MHz	+25°C		-98	dB
			f = 1MHz	+25°C		-103	dB
Bandwidth -3 dB	BW	Signal = 0dBm, $R_L = 50\Omega, C_L = 5pF,$ Test Circuit 7	+25°C		300		MHz
POWER REQUIREMENTS							
Power Supply Range	V_+		-40°C to +85°C	1.8		5.5	V
Power Supply Current	I_+	$V_+ = +5.5V, V_{IN} = 0V$ or V_+	-40°C to +85°C			5	μA

Specifications subject to change without notice.

4.0Ω, 300MHz Bandwidth, Dual SPDT Analog Switch

ELECTRICAL CHARACTERISTICS

($V_+ = +4.5V$ to $+5.5V$, $V_{IH} = +2.0V$, $V_{IL} = +0.8V$, $T_A = -40^\circ C$ to $+85^\circ C$, Typical values are at $V_+ = 5.0V$, $T_A = +25^\circ C$, unless otherwise noted.)

PARAMETER	SYMBOL	CONDITIONS	TEMP	MIN	TPY	MAX	UNITS
ANALOG SWITCH							
Analog Signal Range	V_{NO}, V_{NC}, V_{COM}		$-40^\circ C$ to $+85^\circ C$	0		V_+	V
On-Resistance	R_{ON}	$V_+ = 4.5V, V_{NO}$ or $V_{NC} = 3.5V,$ $I_{COM} = -10$ mA, Test Circuit 1	$+25^\circ C$		4.5	8	Ω
			$-40^\circ C$ to $+85^\circ C$			8.5	Ω
On-Resistance Match Between Channels	ΔR_{ON}	$V_+ = 4.5V, V_{NO}$ or $V_{NC} = 3.5V,$ $I_{COM} = -10$ mA, Test Circuit 1	$+25^\circ C$		0.15	0.3	Ω
			$-40^\circ C$ to $+85^\circ C$			0.8	Ω
On-Resistance Flatness	$R_{FLAT(ON)}$	$V_+ = 4.5V, V_{NO}$ or $V_{NC} = 1.0V, 2.0V,$ $3.5V, I_{COM} = -10$ mA, Test Circuit 1	$+25^\circ C$		2.3	3.3	Ω
			$-40^\circ C$ to $+85^\circ C$			3.7	Ω
Source OFF Leakage current	$I_{NC(OFF)}, I_{NO(OFF)}$	$V_+ = 5.5V, V_{NO}$ or $V_{NC} = 1.0V, 4.5V,$ $V_{COM} = 1.0V, 4.5V,$	$-40^\circ C$ to $+85^\circ C$			1	μA
Channel ON Leakage current	$I_{NC(ON)}, I_{NO(ON)},$ $I_{COM(ON)}$	$V_+ = 5.5V, V_{COM} = 1.0V, 4.5V,$ V_{NO} or $V_{NC} = 1.0V, 4.5V,$ or floating	$-40^\circ C$ to $+85^\circ C$			1	μA
DIGITAL INPUTS							
Input High Voltage	V_{INH}		$-40^\circ C$ to $+85^\circ C$	1.5			V
Input Low Voltage	V_{INL}		$-40^\circ C$ to $+85^\circ C$			0.6	V
Input Leakage Current	I_{IN}	$V_+ = +5.5V, V_{IN} = 0$ or $5.5V$	$-40^\circ C$ to $+85^\circ C$			1	μA
DYNAMIC CHARACTERISTICS							
Turn-On Time	t_{ON}	V_{NO} or $V_{NC} = 3.0V,$ $R_L = 300\Omega, C_L = 35pF,$ Test Circuit 2; $V_{IH} = 1.5V, V_{IL} = 0V$	$+25^\circ C$		26		ns
Turn-Off Time	t_{OFF}	V_{NO} or $V_{NC} = 3.0V,$ $R_L = 300\Omega, C_L = 35pF,$ Test Circuit 2; $V_{IH} = 1.5V, V_{IL} = 0V$	$+25^\circ C$		20		ns
Break-Before-Make Time Delay	t_D	V_{NO1} or $V_{NC1} = V_{NO2}$ or $V_{NC2} = 3V,$ $R_L = 300\Omega, C_L = 35pF,$ Test Circuit 3	$+25^\circ C$		4		ns
Skew	t_{SKEW}	$R_S = 39\Omega, C_L = 50pF,$ Test Circuit 4	$+25^\circ C$		5.8		ns
Off Isolation	O_{ISO}	$R_L = 50\Omega, C_L = 5pF,$ Signal = 0dBm, Test Circuit 5	$f = 10MHz$	$+25^\circ C$		-57	dB
			$f = 1MHz$	$+25^\circ C$		-76	dB
Channel-to-Channel Crosstalk	X_{TALK}	$R_L = 50\Omega, C_L = 5pF,$ Test Circuit 6	$f = 10MHz$	$+25^\circ C$		-99	dB
			$f = 1MHz$	$+25^\circ C$		-110	dB
Total Harmonic Distortion	THD	$V_{COM} = 2V_{P-P}, R_L = 50\Omega, C_L = 5pF$	$+25^\circ C$				%
Bandwidth -3 dB	BW	Signal = 0dBm, $R_L = 50\Omega, C_L = 5pF,$ Test Circuit 7	$+25^\circ C$		300		MHz
POWER REQUIREMENTS							
Power Supply Range	V_+		$-40^\circ C$ to $+85^\circ C$	1.8		5.5	V
Power Supply Current	I_+	$V_+ = +5.5V, V_{IN} = 0V$ or V_+	$-40^\circ C$ to $+85^\circ C$			5	μA

Specifications subject to change without notice.

4.0Ω, 300MHz Bandwidth, Dual SPDT Analog Switch

ORDERING INFORMATION

MODEL	PIN-PACKAGE	SPECIFIED TEMPERATURE RANGE	ORDERING NUMBER	PACKAGE MARKING	PACKAGE OPTION
BCT4717ETB	WQFN-10	- 40°C to +85°C	BCT4717ETB	ALX	Tape and Reel, 3000

ABSOLUTE MAXIMUM RATINGS

V ₊ , IN to GND.....	- 0.3V to +6V	Junction Temperature.....+150°C
Analog, Digital voltage range(1).....	- 0.3V to (V ₊ + 0.3V)	Storage Temperature.....	to +150°C
Continuous Current NO, NC, or COM.....	±200mA	Lead Temperature (soldering, 10s).....	+260°C
Peak Current NO, NC, or COM.....	±300mA	ESD (HBM)	2000V
Operating Temperature Range.....	- 40°C to +85°C		

Stresses beyond those listed under “Absolute Maximum Ratings” may cause permanent damage to the device. These are stress ratings only, and functional operation of the device at these or any other conditions beyond those indicated in the operational sections of the specifications is not implied. Exposure to absolute maximum rating conditions for extended periods may affect device reliability.

(1) Signals on NC, NO, or COM or IN exceeding V₊ will be clamped by internal diodes. Limit forward diode current to maximum current ratings.

PIN DESCRIPTION

NAME	FUNCTION
V ₊	Power supply
GND	ground
IN1, IN2	Digital control pin to connect the COM terminal to the NO or NC terminals
COM1, COM2	Common terminal
NO1, NO2	Normally-open terminal
NC1, NC2	Normally-closed terminal

Note: NO, NC and COM terminal may be an input or output.

4.0Ω, 300MHz Bandwidth, Dual SPDT Analog Switch

TYPICAL PERFORMANCE CHARACTERISTICS

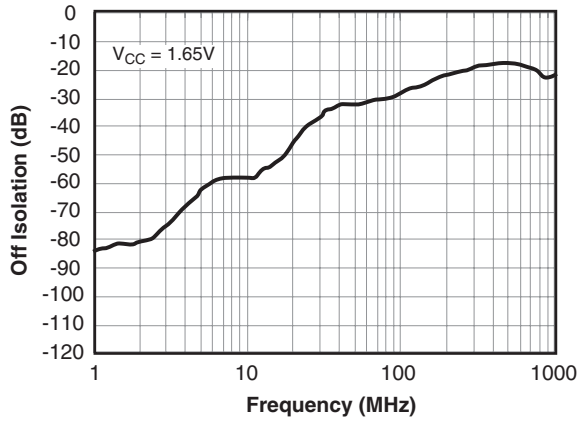

Figure 1. Off Isolation, $V_{CC} = 1.65V$

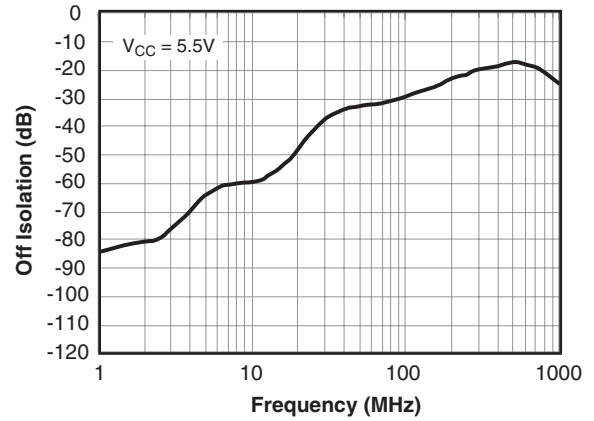

Figure 2. Off Isolation, $V_{CC} = 5.5V$

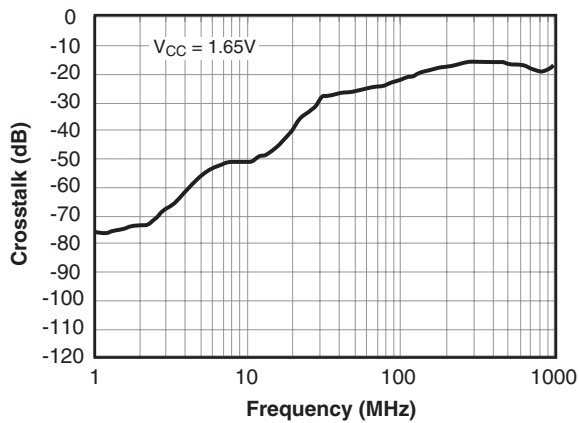

Figure 3. Crosstalk, $V_{CC} = 1.65V$

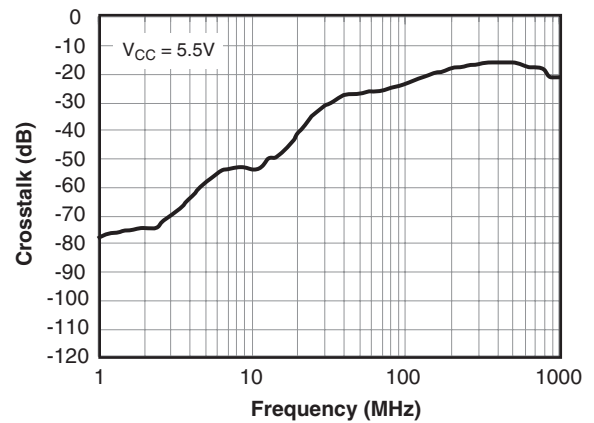

Figure 4. Crosstalk, $V_{CC} = 5.5V$

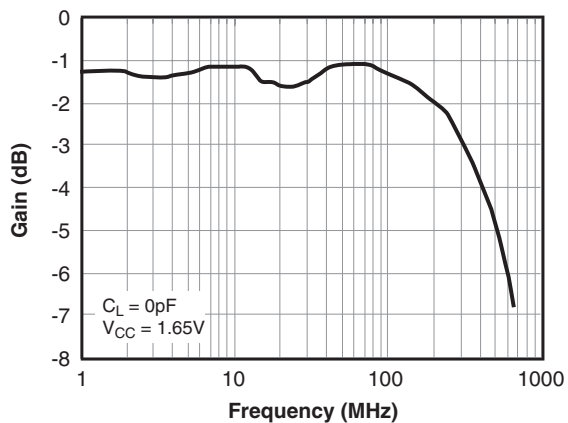
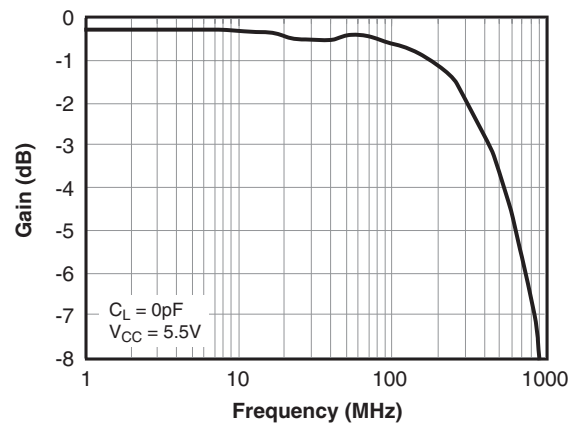
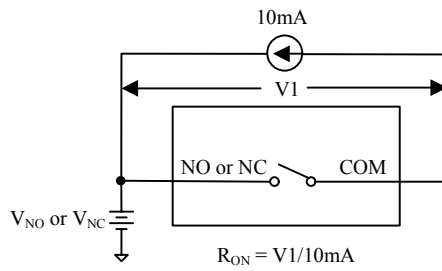

Figure 5. Bandwidth, V_{CC}



$V_{CC} = 5.5V$

4.0Ω, 300MHz Bandwidth, Dual SPDT Analog Switch TEST CIRCUITS



Test Circuit 1. On Resistance

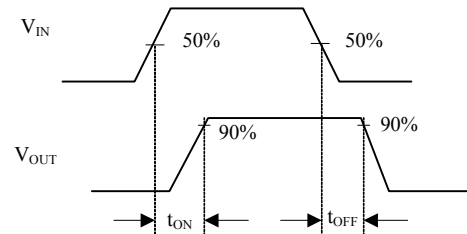
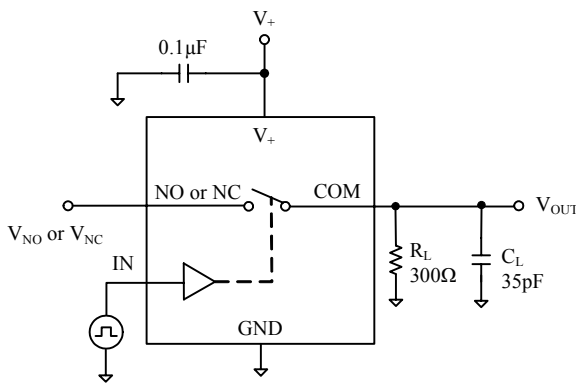

Test Circuit 2. Switching Times

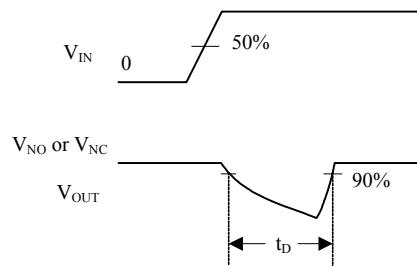
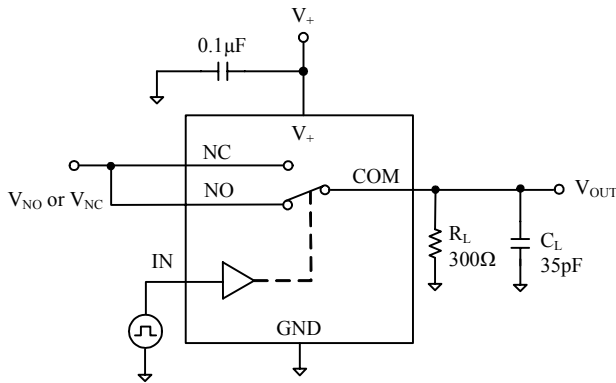

Test Circuit 3. Break-Before-Make Time Delay, t_D

4.0Ω, 300MHz Bandwidth, Dual SPDT Analog Switch

TEST CIRCUITS (Cont.)

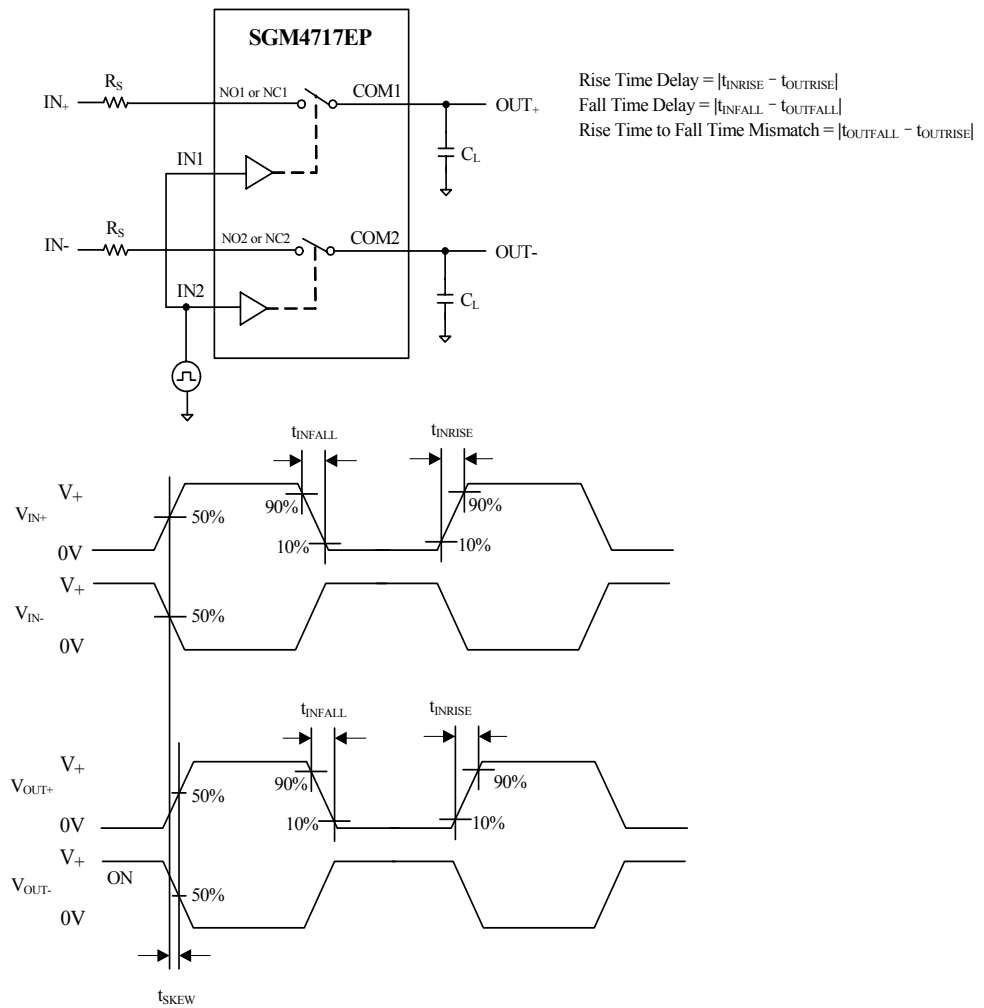

Test Circuit 4. Output Signal Skew

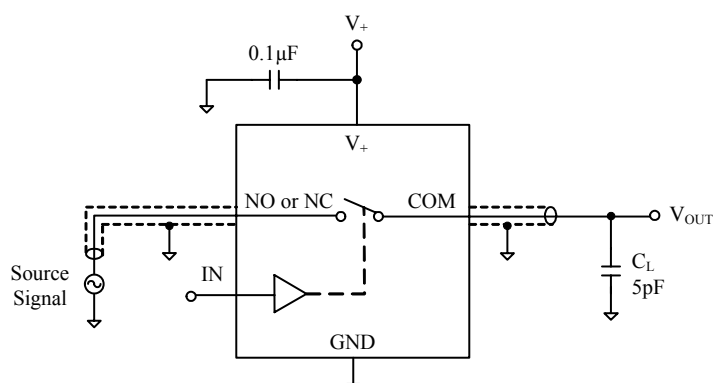

Test Circuit 5. Off Isolation

4.0Ω, 300MHz Bandwidth, Dual SPDT Analog Switch

TEST CIRCUITS (Cont.)

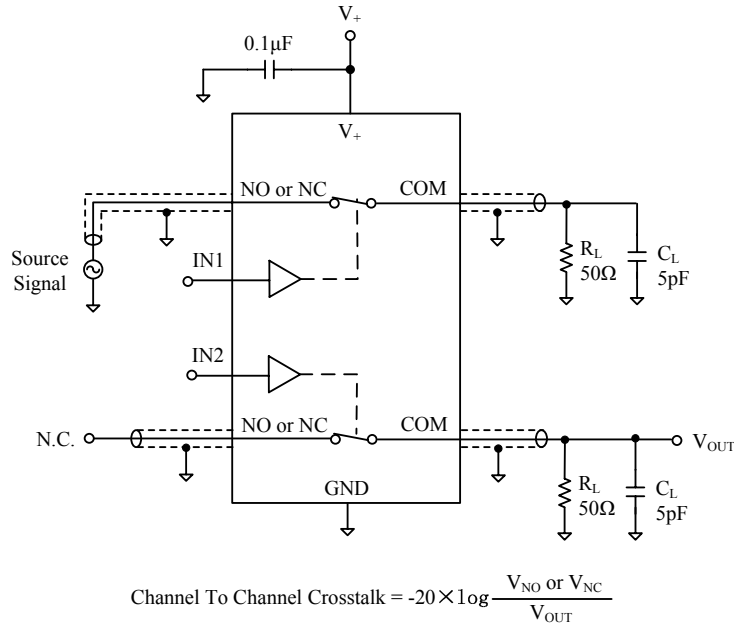

Test Circuit 6. Channel-to-Channel Crosstalk

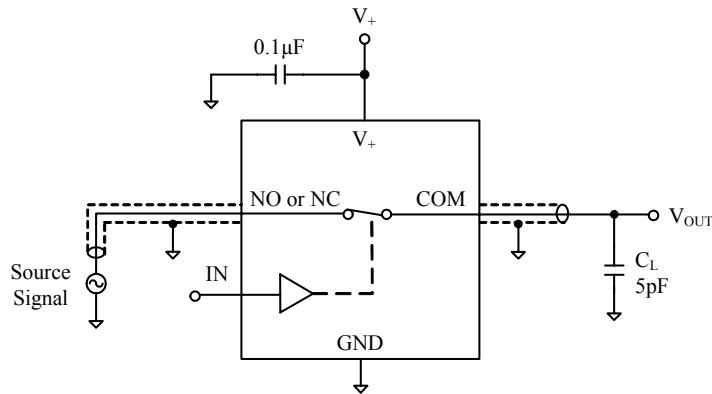

Test Circuit 7. Bandwidth

4.0Ω, 300MHz Bandwidth, Dual SPDT Analog Switch

PACKAGE OUTLINE DIMENSIONS

WQFN-10

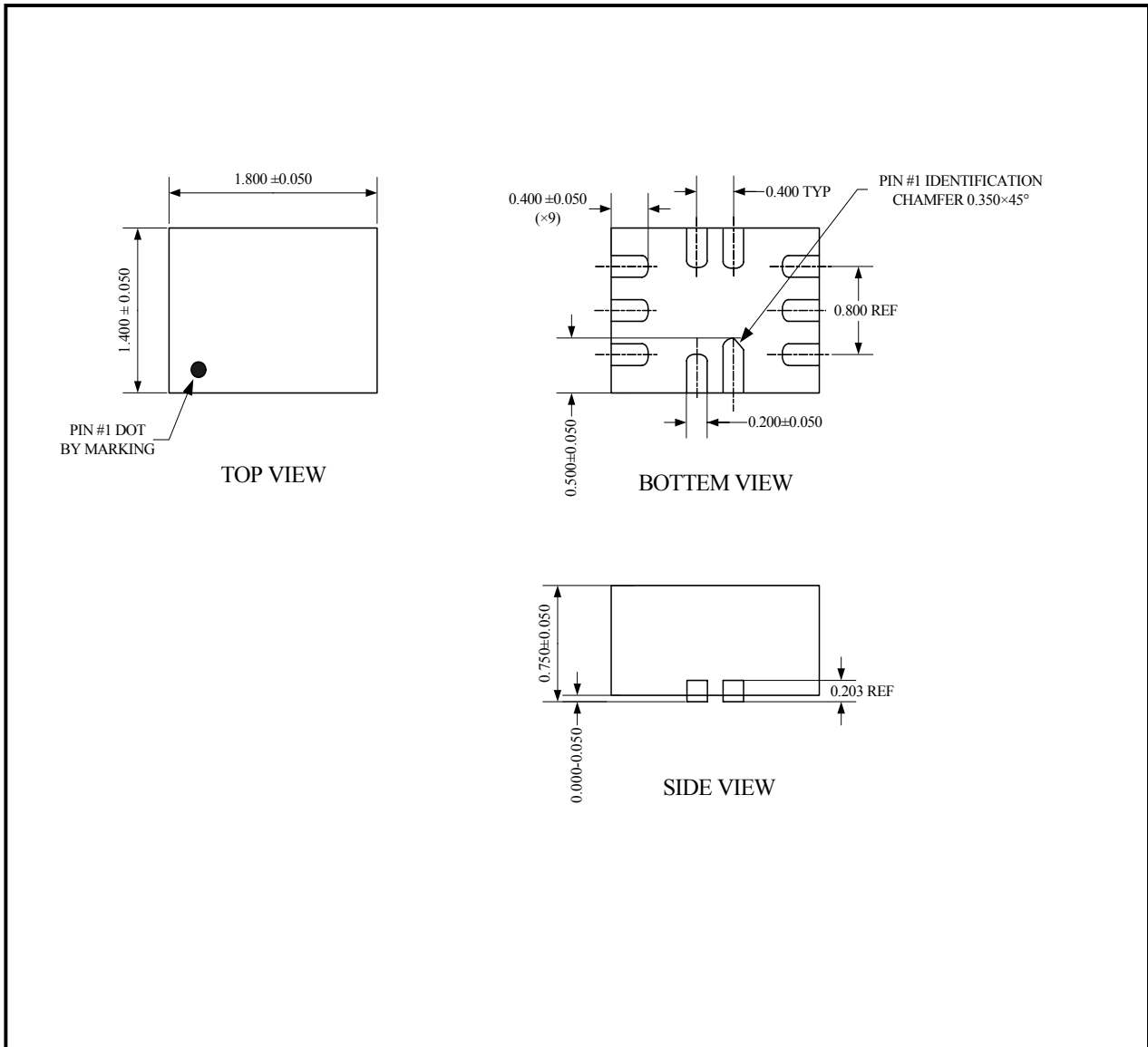

Note: All linear dimensions are in millimeters.