

SOT-23 Formed SMD Package

**BCW69
BCW70**

SILICON PLANAR EPITAXIAL TRANSISTORS

P-N-P transistors

Marking

BCW69 = H1
BCW70 = H2

Pin configuration

1 = BASE
2 = EMITTER
3 = COLLECTOR

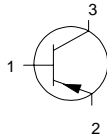
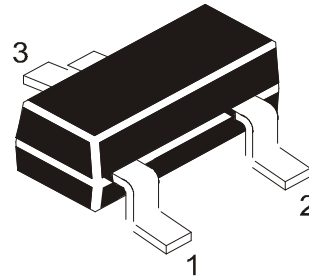

ABSOLUTE MAXIMUM RATINGS

D.C. current gain at $T_j = 25\text{ }^\circ\text{C}$
 $-I_C = 2\text{ mA}; -V_{CE} = 5\text{ V}$
 Collector-base voltage (open emitter)
 Collector-emitter voltage (open base)
 Collector current (peak value)
 Total power dissipation up to $T_{amb} = 25\text{ }^\circ\text{C}$
 Junction temperature
 Transition frequency at $f = 35\text{ MHz}$
 $-I_C = 10\text{ mA}; -V_{CE} = 5\text{ V}$
 Noise figure at $R_S = 2\text{ k}\Omega$
 $-I_C = 200\text{ }\mu\text{A}; -V_{CE} = 5\text{ V};$
 $f = 1\text{ kHz}; B = 200\text{ Hz}$

		BCW69	BCW70
h_{FE}	>	120	215
h_{FE}	<	260	500
$-V_{CB0}$	max.	50	V
$-V_{CE0}$	max.	45	V
$-I_{CM}$	max.	200	mA
P_{tot}	max.	250	mW
T_j	max.	150	$^\circ\text{C}$
f_T	typ.	150	MHz
F	<	10	dB

BCW69
BCW70

RATINGS (at $T_A = 25^\circ\text{C}$ unless otherwise specified)

Limiting values

Collector-base voltage (open emitter)	$-V_{CB0}$	max.	50 V
Collector-emitter voltage ($V_{BE} = 0$)	$-V_{CES}$	max.	50 V
Collector-emitter voltage (open base)			
$-I_C = 2$ mA	$-V_{CE0}$	max.	45 V
Emitter-base voltage (open collector)	$-V_{EB0}$	max.	5 V
Collector current (d.c.)	$-I_C$	max.	100 mA
Collector current (peak value)	$-I_{CM}$	max.	200 mA
Total power dissipation up to $T_{amb} = 25^\circ\text{C}$	P_{tot}	max.	250 mW
Storage temperature	T_{stg}		-55 to +150 °C
Junction temperature	T_j	max.	150 °C

THERMAL RESISTANCE

From junction to ambient	$R_{th\ j-a}$	=	500 K/W
--------------------------	---------------	---	---------

CHARACTERISTICS

$T_j = 25^\circ\text{C}$ unless otherwise specified

Collector cut-off current

$I_E = 0; -V_{CB} = 20$ V	$-I_{CB0}$	<	100 nA
---------------------------	------------	---	--------

$I_E = 0; -V_{CB} = 20$ V; $T_j = 100^\circ\text{C}$	$-I_{CB0}$	<	10 μA
--	------------	---	------------------

Base-emitter voltage

$-I_C = 2$ mA; $-V_{CE} = 5$ V	$-V_{BE}$		600 to 750 mV
--------------------------------	-----------	--	---------------

Saturation voltages

$-I_C = 10$ mA; $-I_B = 0,5$ mA	$-V_{CEsat}$	typ.	80 mV
			< 300 mV
	$-V_{BEsat}$	typ.	720 mV

$-I_C = 50$ mA; $-I_B = 2,5$ mA	$-V_{CEsat}$	typ.	150 mV
---------------------------------	--------------	------	--------

	$-V_{BEsat}$	typ.	810 mV
--	--------------	------	--------

D.C. current gain

$-I_C = 10$ μA ; $-V_{CE} = 5$ V	h_{FE}	typ.	BCW69 90	BCW70 150
---	----------	------	-----------------	------------------

$-I_C = 2$ mA; $-V_{CE} = 5$ V	h_{FE}	>	120	215
--------------------------------	----------	---	-----	-----

h_{FE}	<	260	500
----------	---	-----	-----

Collector capacitance at $f = 1$ MHz

$I_E = I_e = 0; -V_{CB} = 10$ V	C_c	typ.	4,5	pF
---------------------------------	-------	------	-----	----

Transition frequency at $f = 35$ MHz

$-I_C = 10$ mA; $-V_{CE} = 5$ V	f_T	typ.	150	MHz
---------------------------------	-------	------	-----	-----

Noise figure at $R_S = 2$ k Ω

$-I_C = 200$ μA ; $-V_{CE} = 5$ V	F	<	10	dB
$f = 1$ kHz; $B = 200$ Hz				

SOT-23 Formed SMD Package

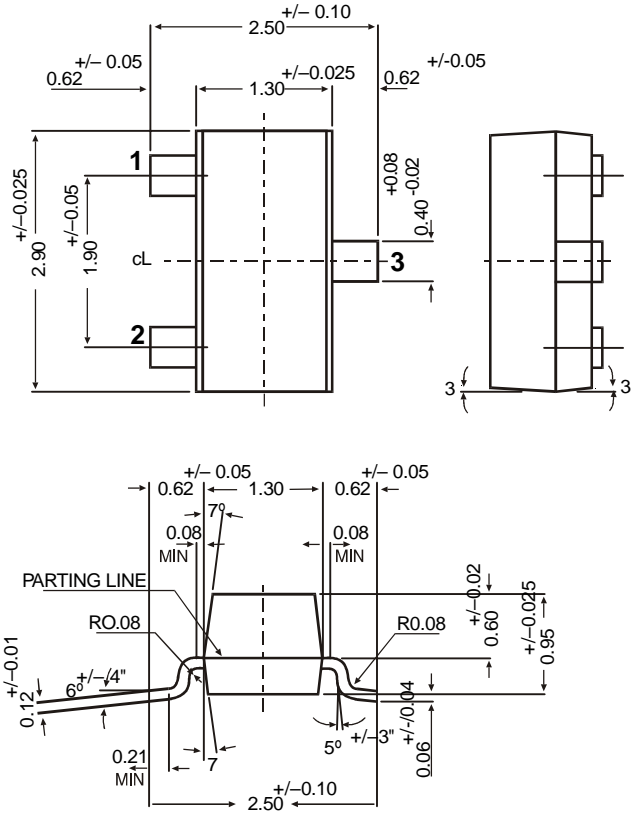

SOT-23 Package Reel Information
Reel specifications for Packing (13"/7" reels)

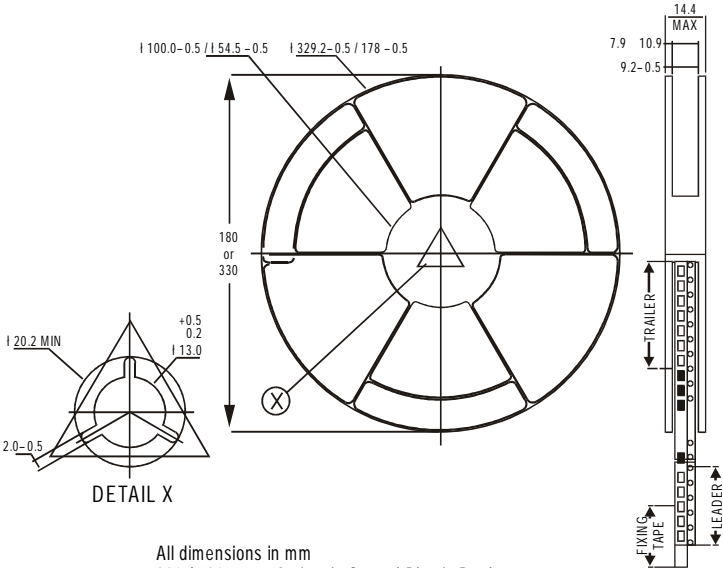

All dimensions in mm
330 / 180 mm Antistatic Coated Plastic Reel

- NOTES:
- | No. of Devices | 8mm Tape Size of Reel | 8mm Tape Size of Reel |
|----------------|-----------------------|-----------------------|
| | 330 mm (13") | 180 mm (7") |
| | 10,000 Pcs | 3,000 Pcs |
- The bandolier of 330 mm reel contains at least 10,000 devices.
 - The bandolier of 180 mm reel contains at least 3,000 devices.
 - No more than 0.5% missing devices / reel. 50 empty compartments for 330 mm reel. 15 empty compartments for 180 mm reel.
 - Three consecutive empty places might be found provided this gap is followed by 6 consecutive devices.
 - The carrier tape (leader) starts with at least 75 empty positions (equivalent to 330 mm). In order to fix the carrier tape a self adhesive tape of 20 to 50 mm is applied. At the end of the bandolier at least 40 empty positions (equivalent to 160 mm) are there.

Tape Specification for SOT-23 Surface Mount Device

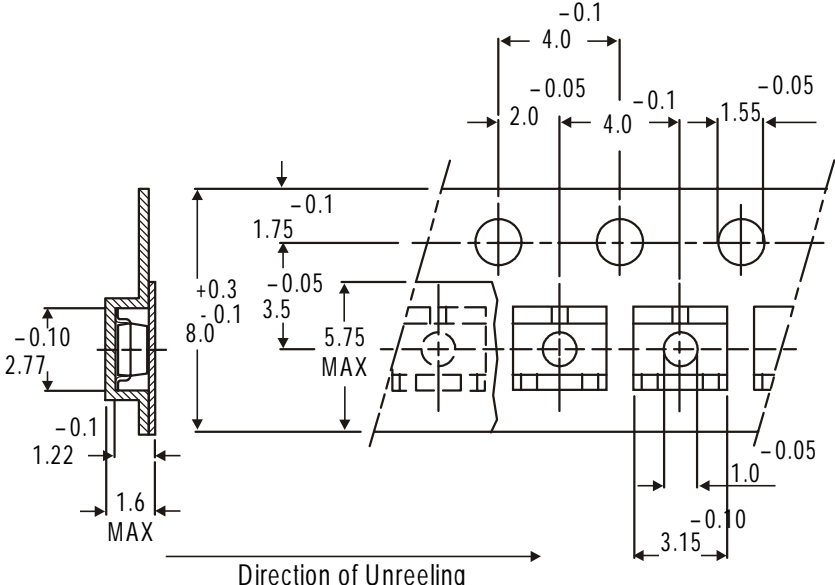

All dimensions in mm

Packing Detail

PACKAGE	STANDARD PACK		INNER CARTON BOX		OUTER CARTON BOX		
	Details	Net Weight/Qty	Size	Qty	Size	Qty	Gr Wt
SOT-23 T&R	3K/reel	136 gm/3K pcs	3" x 7.5" x 7.5"	12.0K	17" x 15" x 13.5"	192.0K	12 kgs
			9" x 9" x 9"	51.0K	19" x 19" x 19"	408.0K	28 kgs
	10K/reel	415 gm/10K pcs	13" x 13" x 0.5"	10.0K	17" x 15" x 13.5"	300.0K	16 kgs

Customer Notes

Component Disposal Instructions

1. CDIL Semiconductor Devices are RoHS compliant, customers are requested to please dispose as per prevailing Environmental Legislation of their Country.
2. In Europe, please dispose as per EU Directive 2002/96/EC on Waste Electrical and Electronic Equipment (WEEE).

Disclaimer

The product information and the selection guides facilitate selection of the CDIL's Discrete Semiconductor Device(s) best suited for application in your product(s) as per your requirement. It is recommended that you completely review our Data Sheet(s) so as to confirm that the Device(s) meet functionality parameters for your application. The information furnished on the CDIL Web Site/CD are believed to be accurate and reliable. CDIL however, does not assume responsibility for inaccuracies or incomplete information. Furthermore, CDIL does not assume liability whatsoever, arising out of the application or use of any CDIL product; neither does it convey any license under its patent rights nor rights of others. These products are not designed for use in life saving/support appliances or systems. CDIL customers selling these products (either as individual Discrete Semiconductor Devices or incorporated in their end products), in any life saving/support appliances or systems or applications do so at their own risk and CDIL will not be responsible for any damages resulting from such sale(s).

CDIL strives for continuous improvement and reserves the right to change the specifications of its products without prior notice.



CDIL is a registered Trademark of
Continental Device India Limited

C-120 Naraina Industrial Area, New Delhi 110 028, India.

Telephone + 91-11-2579 6150, 4141 1112 Fax + 91-11-2579 5290, 4141 1119

email@cdil.com www.cdilsemi.com