

BCW70

Rev.E Mar.-2016

描述 / Descriptions

SOT-23 塑封封装 PNP 半导体三极管。Silicon PNP transistor in a SOT-23 Plastic Package.

特征 / Features

低电流，低电压。

Low current, low voltage.

用途 / Applications

用于一般开关和放大。

General purpose switching and amplifier applications.

内部等效电路 / Equivalent Circuit

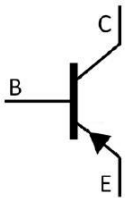

引脚排列 / Pinning



PIN 1 : Emitter

PIN 2 : Base

PIN 3 : Collector

放大及印章代码 / h_{FE} Classifications & Marking

| | |
|----------------|---------|
| h_{FE} Range | 215~500 |
| Marking | HH2 |

极限参数 / Absolute Maximum Ratings(Ta=25°C)

| 参数 Parameter | 符号 Symbol | 数值 Rating | 单位 Unit |
|------------------------------|--------------|--------------|------------|
| Collector to Base Voltage | V_{CBO} | -50 | V |
| Collector to Emitter Voltage | V_{CEO} | -45 | V |
| Emitter to Base Voltage | V_{EBO} | -5.0 | V |
| Collector Current(DC) | I_C | -100 | mA |
| Peak Collector Current | I_{CM} | -200 | mA |
| Peak Base Current | I_{BM} | -200 | mA |
| Collector Power Dissipation | P_C | 250 | mW |
| Junction Temperature | T_j | 150 | °C |
| Storage Temperature Range | T_{stg} | -55~150 | °C |

电性能参数 / Electrical Characteristics(Ta=25°C)

| 参数 Parameter | 符号 Symbol | 测试条件 Test Conditions | 最小值 Min | 典型值 Typ | 最大值 Max | 单位 Unit |
|---|------------------|--|------------|------------|------------|------------|
| Collector to Base Breakdown Voltage | V_{CBO} | $I_C=-100\mu A$ $I_E=0$ | -50 | | | V |
| Collector to Emitter Breakdown Voltage | V_{CEO} | $I_C=-500\mu A$ $I_B=0$ | -45 | | | V |
| Emitter to Base Breakdown Voltage | V_{EBO} | $I_E=-100\mu A$ $I_C=0$ | -5.0 | | | V |
| Collector Cut-Off Current | I_{CBO} | $V_{CB}=-20 V$ $I_E=0$ | | | -0.1 | μA |
| Emitter Base Cut-Off Current | I_{EBO} | $V_{EB}=-5.0V$ $I_C=0$ | | | -0.1 | μA |
| DC Current Gain | $h_{FE(1)}$ | $V_{CE}=-5.0V$ $I_C=-2.0mA$ | 215 | | 500 | |
| | $h_{FE(2)}$ | $V_{CE}=-5.0V$ $I_C=-10\mu A$ | | 150 | | |
| Collector to Emitter Saturation Voltage | $V_{CE(sat)(1)}$ | $I_C=-10mA$ $I_B=-0.5mA$ | | -80 | -300 | mV |
| | $V_{CE(sat)(2)}$ | $I_C=-50mA$ $I_B=-2.5mA$ | | -150 | | mV |
| Base to Emitter Saturation Voltage | $V_{BE(sat)(1)}$ | $I_C=-10mA$ $I_B=-0.5mA$ | | -720 | | mV |
| | $V_{BE(sat)(2)}$ | $I_C=-50mA$ $I_B=-2.5mA$ | | -810 | | mV |
| Base-Emitter On Voltage | V_{BE} | $V_{CE}=-5.0V$ $I_C=-2.0mA$ | -600 | | -750 | mV |
| Transition Frequency | f_T | $I_C=-10mA$ $V_{CE}=-5.0V$ $f=100MHz$ | 100 | | | MHz |
| Collector Capacitance | C_C | $V_{CB}=-10V$ $I_E=0$ $f=1MHz$ | | 4.5 | | pF |
| Noise Figure | NF | $V_{CE}=-5.0V$ $I_C=-200\mu A$ $R_S=2K\Omega$ $f=1KHz$ $B=200Hz$ | | | 10 | dB |

电参数曲线图 / Electrical Characteristic Curve

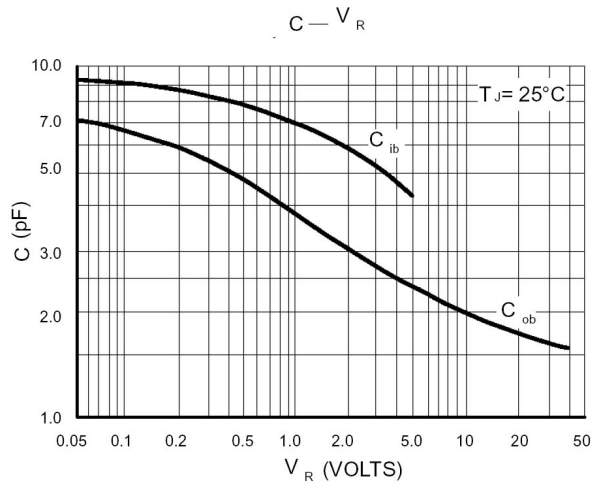
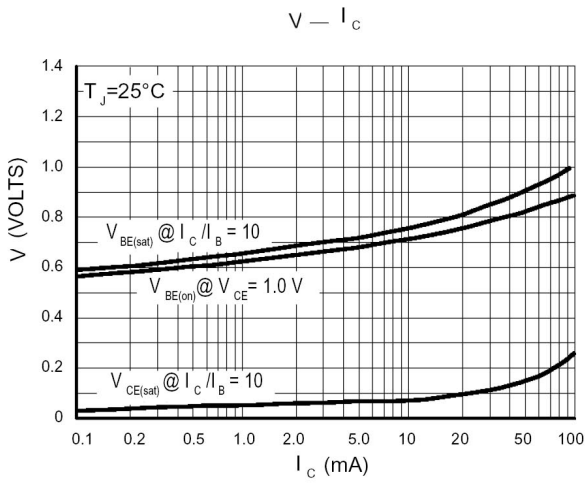
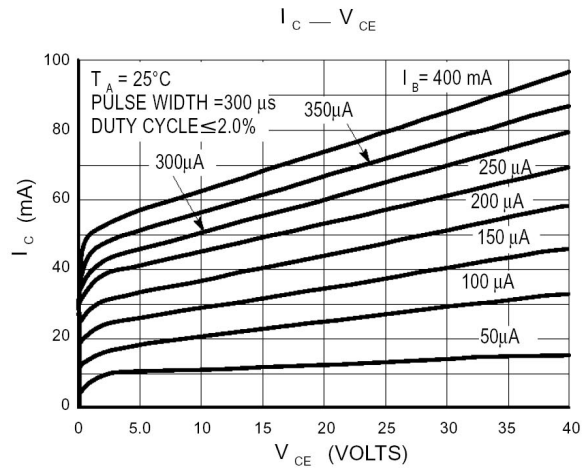
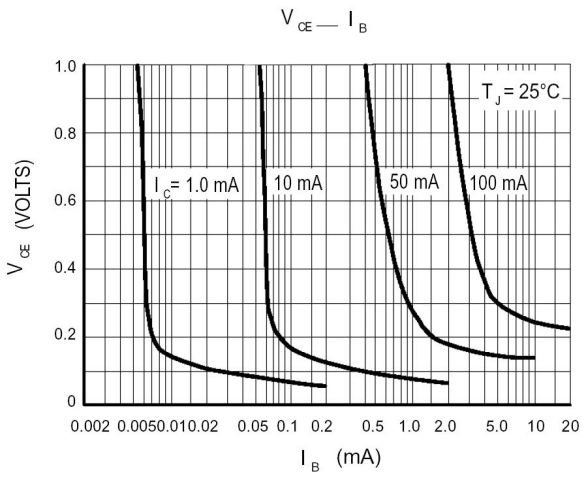

外形尺寸图 / Package Dimensions

SOT-23

单位: mm

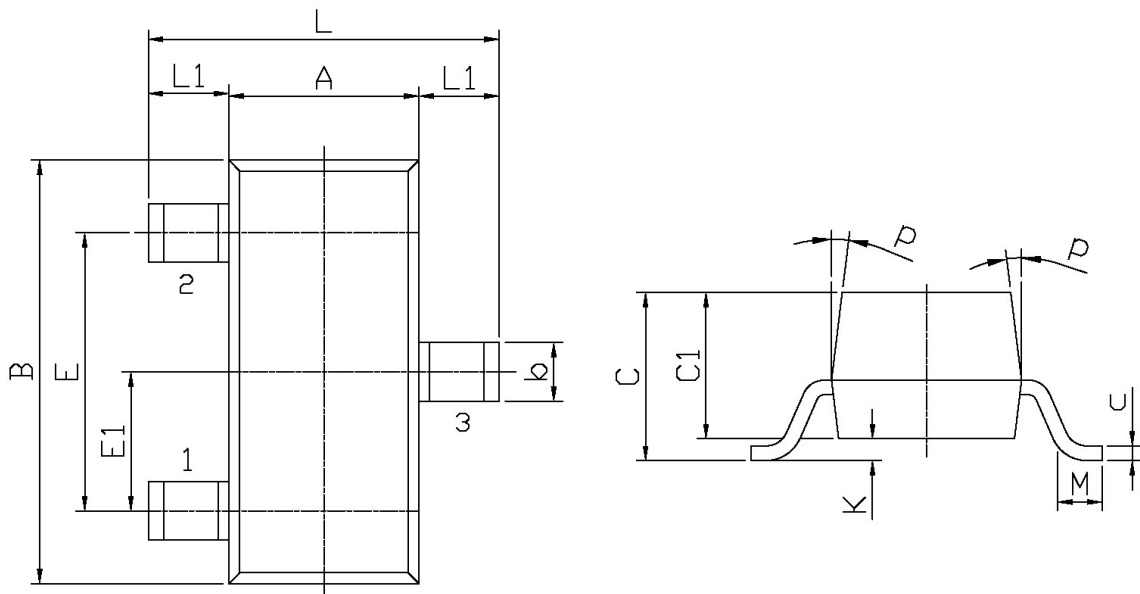

| Symbol | Dimensions In Millimeters | | Symbol | Dimensions In Millimeters | |
|--------|---------------------------|------|--------|---------------------------|------|
| | Min | Max | | Min | Max |
| L | 2.2 | 2.7 | C | 1.30Max | |
| L1 | 0.45 | 0.65 | C1 | 0.90 | 1.20 |
| A | 1.15 | 1.50 | c | 0.05 | 0.20 |
| B | 2.70 | 3.10 | K | 0 | 0.10 |
| E | 1.70 | 2.10 | M | 0.20MIN | |
| E1 | 0.85 | 1.05 | P | 7° | |
| b | 0.35 | 0.55 | | | |

印章说明 / Marking Instructions

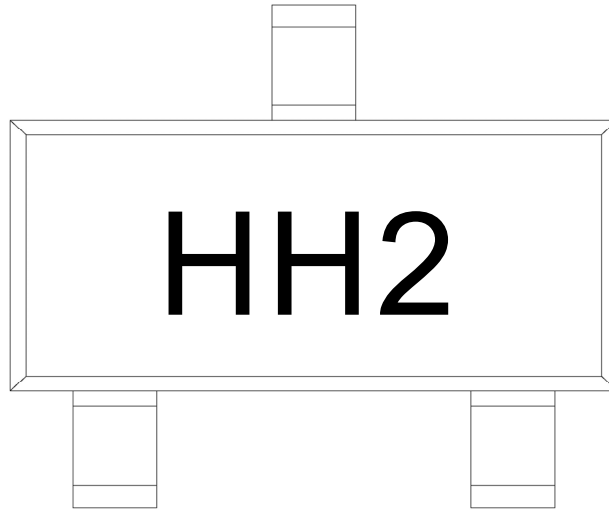

说明：

H： 为公司代码

H2： 为型号代码

Note:

H: Company Code

H2: Product Type Code

回流焊温度曲线图(无铅) / Temperature Profile for IR Reflow Soldering(Pb-Free)



说明：

- 1、预热温度 25~150°C，时间 60~90sec;
- 2、峰值温度 245±5°C，时间持续为 5±0.5sec;
- 3、焊接制程冷却速度为 2~10°C/sec.

Note:

- 1.Preheating:25~150°C, Time:60~90sec.
- 2.Peak Temp.:245±5°C, Duration:5±0.5sec.
3. Cooling Speed: 2~10°C/sec.

耐焊接热试验条件 / Resistance to Soldering Heat Test Conditions

温度：260±5°C 时间：10±1 sec. Temp.:260±5°C Time:10±1 sec

包装规格 / Packaging SPEC.

卷盘包装 / REEL

| Package Type 封装形式 | Units 包装数量 | | | | | Dimension 包装尺寸 (unit: mm ³) | | |
|----------------------|--------------------|-------------------------|------------------------|------------------------------|------------------------|---|-------------|-------------|
| | Units/Reel 只/卷盘 | Reels/Inner Box 卷盘/盒 | Units/Inner Box 只/盒 | Inner Boxes/Outer Box 盒/箱 | Units/Outer Box 只/箱 | Reel | Inner Box 盒 | Outer Box 箱 |
| SOT-23 | 3,000 | 10 | 30,000 | 8 | 240,000 | 7" x8 | 180×120×180 | 385×257×392 |

使用说明 / Notices