

**SOT-23 Formed SMD Package**

**BCW71  
BCW72**

**SILICON PLANAR EPITAXIAL TRANSISTORS**

*N-P-N transistors*

**Marking**

BCW71 = K1

BCW72 = K2

**Pin configuration**

1 = BASE

2 = EMITTER

3 = COLLECTOR

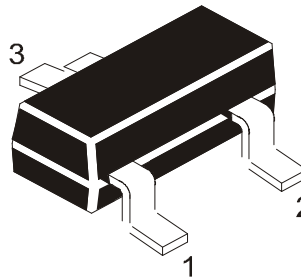
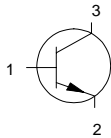

**ABSOLUTE MAXIMUM RATINGS**

		<b>BCW71</b>	<b>BCW72</b>
D.C. current gain at $T_j = 25\text{ }^\circ\text{C}$			
$I_C = 2\text{ mA}; V_{CE} = 5\text{ V}$	$h_{FE} >$	110	200
Collector-base voltage (open emitter)	$h_{FE} <$	220	450
Collector-emitter voltage (open base)	$V_{CB0}\text{ max.}$	50	V
Collector current (peak value)	$V_{CE0}\text{ max.}$	45	V
Total power dissipation up to $T_{amb} = 25\text{ }^\circ\text{C}$	$I_{CM}\text{ max.}$	200	mA
Junction temperature	$P_{tot}\text{ max.}$	250	mW
Transition frequency at $f = 35\text{ MHz}$	$T_j\text{ max.}$	150	$^\circ\text{C}$
Noise figure at $R_S = 2\text{ k}\Omega$	$f_T\text{ typ.}$	300	MHz
	$F <$	10	dB

**BCW71**  
**BCW72**

**RATINGS** (at  $T_A = 25^\circ\text{C}$  unless otherwise specified)

Limiting values

Collector-base voltage (open emitter)

$V_{CB0}$  max. 50 V

Collector-emitter voltage (open base)

$I_C = 2$  mA

$V_{CE0}$  max. 45 V

Emitter-base voltage (open collector)

$V_{EB0}$  max. 5 V

Collector current (d.c.)

$I_C$  max. 100 mA

Collector current (peak value)

$I_{CM}$  max. 200 mA

Total power dissipation up to  $T_{amb} = 25^\circ\text{C}$

$P_{tot}$  max. 250 mW

Storage temperature

$T_{stg}$  -55 to +150 °C

Junction temperature

$T_j$  max. 150 °C

**THERMAL RESISTANCE**

From junction to ambient

$R_{th\ j-a}$  = 500 K/W

**CHARACTERISTICS**

$T_j = 25^\circ\text{C}$  unless otherwise specified

Collector cut-off current

$I_E = 0$ ;  $V_{CB} = 20$  V

$I_{CB0}$  < 100 nA

$I_E = 0$ ;  $V_{CB} = 20$  V;  $T_j = 100^\circ\text{C}$

$I_{CB0}$  < 10  $\mu\text{A}$

Base emitter voltage

$I_C = 2$  mA;  $V_{CE} = 5$  V

$V_{BE}$  550 to 700 mV

Saturation voltages

$I_C = 10$  mA;  $I_B = 0,5$  mA

typ. 120 mV

$V_{CEsat}$  < 250 mV

$V_{BEsat}$  typ. 750 mV

$I_C = 50$  mA;  $I_B = 2,5$  mA

$V_{CEsat}$  typ. 210 mV

$V_{BEsat}$  typ. 850 mV

D.C. current gain

$I_C = 10$   $\mu\text{A}$ ;  $V_{CE} = 5$  V

		<b>BCW71</b>	<b>BCW72</b>
$h_{FE}$	typ.	90	150
	>	110	200
	<	220	450

$I_C = 2$  mA;  $V_{CE} = 5$  V

$h_{FE}$  > 110  
< 220

Collector capacitance at  $f = 1$  MHz

$I_E = I_e = 0$ ;  $V_{CB} = 10$  V

$C_c$  typ. 2,5 pF

Transition frequency at  $f = 35$  MHz

$I_C = 10$  mA;  $V_{CE} = 5$  V

$f_T$  typ. 300 MHz

Noise figure at  $R_S = 2$  k $\Omega$

$I_C = 200$   $\mu\text{A}$ ;  $V_{CE} = 5$  V

$f = 1$  kHz;  $B = 200$  Hz

$F$  < 10 dB

**SOT-23 Formed SMD Package**

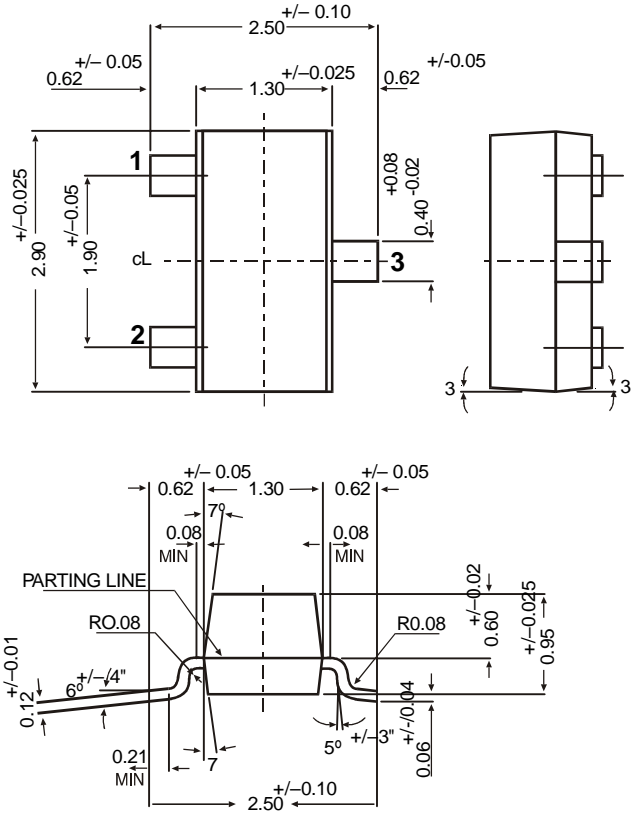

**SOT-23 Package Reel Information**  
**Reel specifications for Packing (13"/7" reels)**

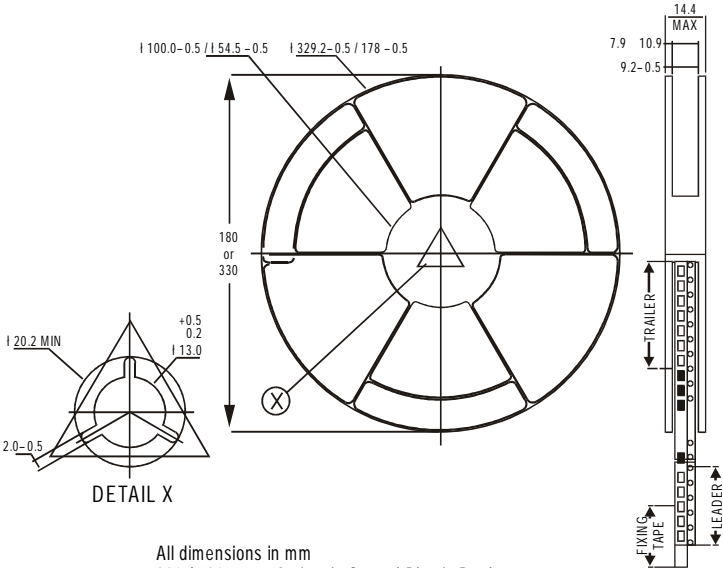

- NOTES:
- | No. of Devices | 8mm Tape Size of Reel | 8mm Tape Size of Reel |
|----------------|-----------------------|-----------------------|
|                | 330 mm (13")          | 180 mm (7")           |
|                | 10,000 Pcs            | 3,000 Pcs             |
- The bandolier of 330 mm reel contains at least 10,000 devices.
  - The bandolier of 180 mm reel contains at least 3,000 devices.
  - No more than 0.5% missing devices / reel. 50 empty compartments for 330 mm reel. 15 empty compartments for 180 mm reel.
  - Three consecutive empty places might be found provided this gap is followed by 6 consecutive devices.
  - The carrier tape (leader) starts with at least 75 empty positions (equivalent to 330 mm). In order to fix the carrier tape a self adhesive tape of 20 to 50 mm is applied. At the end of the bandolier at least 40 empty positions (equivalent to 160 mm) are there.

**Tape Specification for SOT-23 Surface Mount Device**

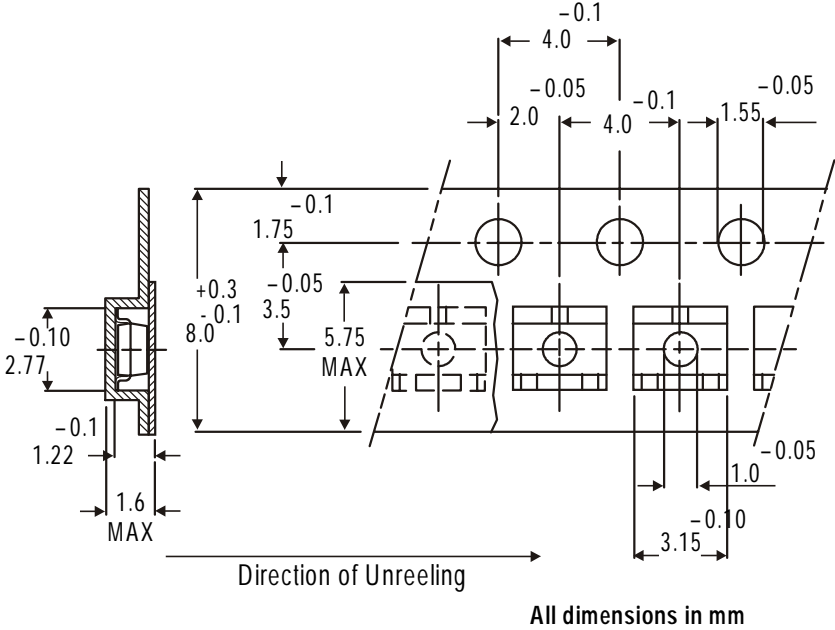

## Packing Detail

PACKAGE	STANDARD PACK		INNER CARTON BOX		OUTER CARTON BOX		
	Details	Net Weight/Qty	Size	Qty	Size	Qty	Gr Wt
SOT-23 T&R	3K/reel	136 gm/3K pcs	3" x 7.5" x 7.5"	12.0K	17" x 15" x 13.5"	192.0K	12 kgs
			9" x 9" x 9"	51.0K	19" x 19" x 19"	408.0K	28 kgs
	10K/reel	415 gm/10K pcs	13" x 13" x 0.5"	10.0K	17" x 15" x 13.5"	300.0K	16 kgs

## Customer Notes

### Component Disposal Instructions

1. CDIL Semiconductor Devices are RoHS compliant, customers are requested to please dispose as per prevailing Environmental Legislation of their Country.
2. In Europe, please dispose as per EU Directive 2002/96/EC on Waste Electrical and Electronic Equipment (WEEE).

## Disclaimer

The product information and the selection guides facilitate selection of the CDIL's Discrete Semiconductor Device(s) best suited for application in your product(s) as per your requirement. It is recommended that you completely review our Data Sheet(s) so as to confirm that the Device(s) meet functionality parameters for your application. The information furnished on the CDIL Web Site/CD are believed to be accurate and reliable. CDIL however, does not assume responsibility for inaccuracies or incomplete information. Furthermore, CDIL does not assume liability whatsoever, arising out of the application or use of any CDIL product; neither does it convey any license under its patent rights nor rights of others. These products are not designed for use in life saving/support appliances or systems. CDIL customers selling these products (either as individual Discrete Semiconductor Devices or incorporated in their end products), in any life saving/support appliances or systems or applications do so at their own risk and CDIL will not be responsible for any damages resulting from such sale(s).

CDIL strives for continuous improvement and reserves the right to change the specifications of its products without prior notice.



CDIL is a registered Trademark of  
Continental Device India Limited

C-120 Naraina Industrial Area, New Delhi 110 028, India.

Telephone + 91-11-2579 6150, 4141 1112 Fax + 91-11-2579 5290, 4141 1119

email@cdil.com www.cdilsemi.com