

## NPN General Purpose Amplifier

## BCW71/BCW72

### FEATURES

- Super Mini Packaged Transistor for Hybrid Circuits.



### APPLICATIONS

- General purpose switching and amplification.
- For Complementary with PNP Type BCW69/70.

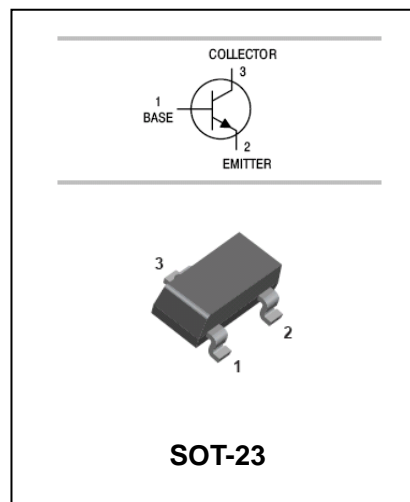

### ORDERING INFORMATION

Type No.	Marking	Package Code
BCW71	K1	SOT-23
BCW72	K2	SOT-23

### MAXIMUM RATING @ Ta=25°C unless otherwise specified

Symbol	Parameter	Value	Unit
V <sub>CB0</sub>	Collector-Base Voltage	50	V
V <sub>CEO</sub>	Collector-Emitter Voltage	45	V
V <sub>EBO</sub>	Emitter-Base Voltage	5	V
I <sub>C</sub>	Collector Current -Continuous	100	mA
P <sub>D</sub>	Total power Dissipation	350	mW
T <sub>j</sub> , T <sub>stg</sub>	Junction and Storage Temperature	-65 to +150	°C



**NPN General Purpose Amplifier**

**BCW71/BCW72**

**ELECTRICAL CHARACTERISTICS @ Ta=25°C unless otherwise specified**

Parameter	Symbol	Test conditions	MIN	Typ	MAX	UNIT
Collector-base breakdown voltage	$V_{(BR)CBO}$	$I_C=10\mu A$ $I_E=0$	50			V
Collector-emitter breakdown voltage	$V_{(BR)CEO}$	$I_C=2mA$ $I_B=0$	45			V
Emitter-base breakdown voltage	$V_{(BR)EBO}$	$I_E=10\mu A$ $I_C=0$	5			V
Collector cut-off current	$I_{CBO}$	$V_{CB}=20V$ $I_E=0$ $V_{CB}=20V$ $I_E=0, T_a=100^\circ C$			100 10	nA $\mu A$
DC current gain	BCW71 BCW72 $h_{FE}$	$V_{CE}=5V$ $I_C=2mA$	110 200		220 450	
Collector-emitter saturation voltage	$V_{CE(sat)}$	$I_C=10mA$ $I_B=0.5mA$			0.25	V
Base-emitter saturation voltage	$V_{BE(sat)}$	$I_C=10mA$ $I_B=0.5mA$ $I_C=50mA$ $I_B=2.5mA$		0.75 0.87		V
Base-emitter voltage	$V_{BE}$	$I_C=2mA$ $V_{CE}=5V$	0.55		0.7	V
Collector output capacitance	$C_{ob}$	$I_E=I_e=0, V_{CB}=10V, f=1MHz$			4.0	pF
Transition frequency	$f_T$	$V_{CE}=5V$ $I_C=10mA$ $f=100MHz$		300		MHz
Noise figure	NF	$V_{CE}=5V$ $I_C=200\mu A$ $R_S=2k\Omega$ $f=1kHz$ $B=200Hz$			10	dB

**TYPICAL CHARACTERISTICS @ Ta=25°C unless otherwise specified**

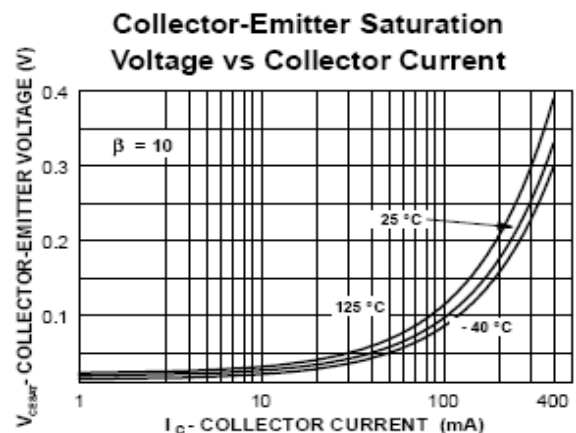
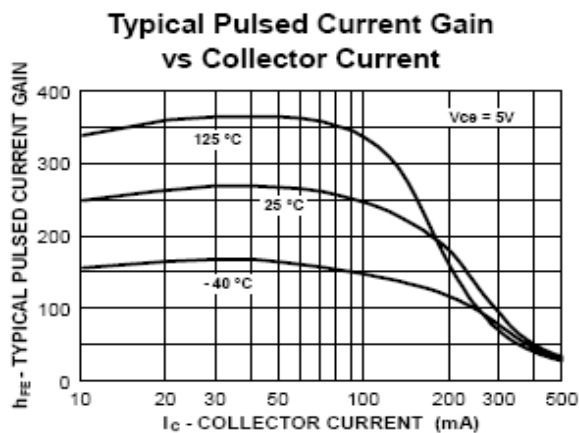



**NPN General Purpose Amplifier**

**BCW71/BCW72**

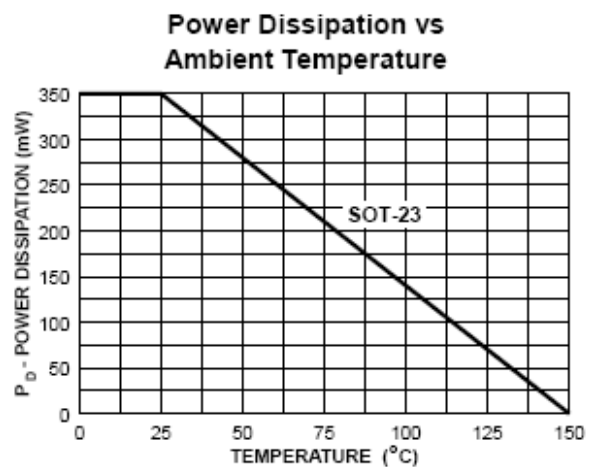
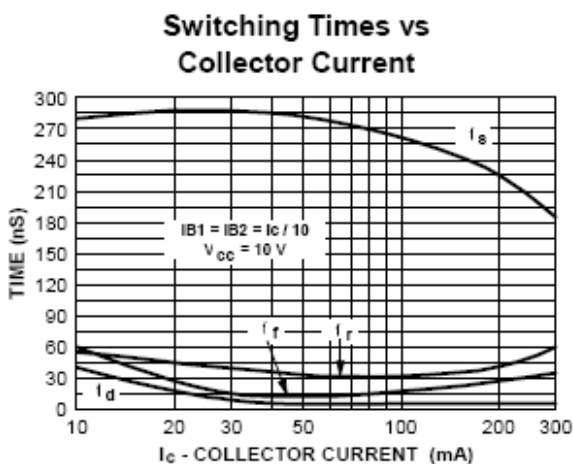
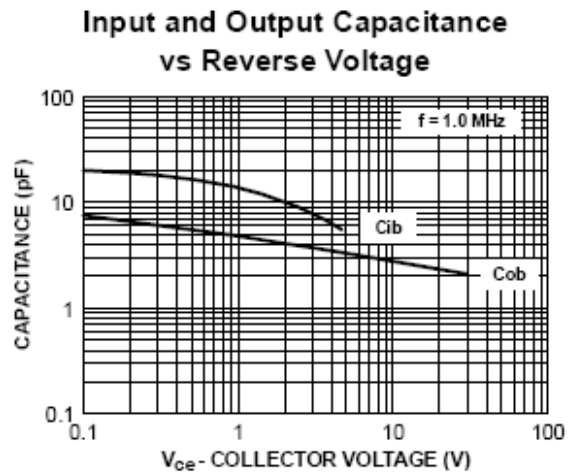
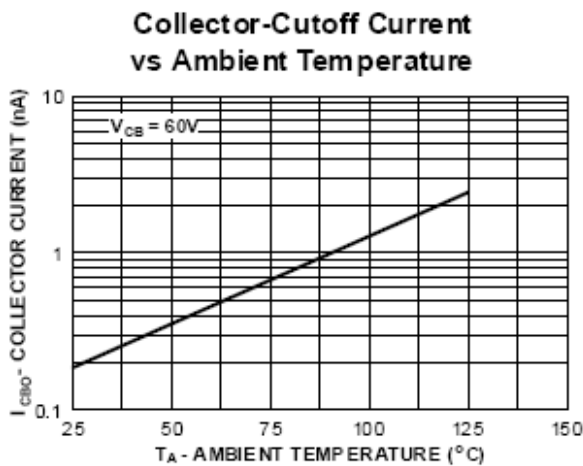
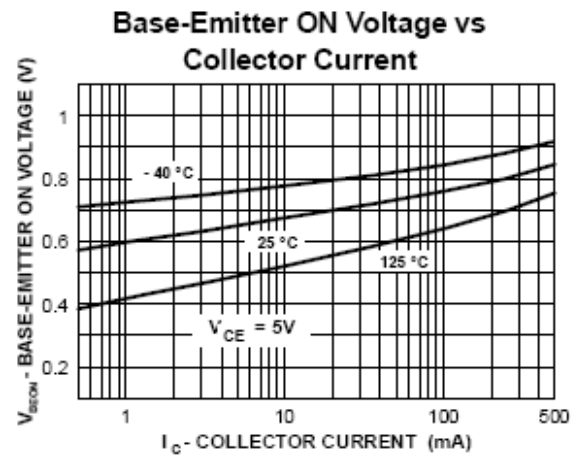
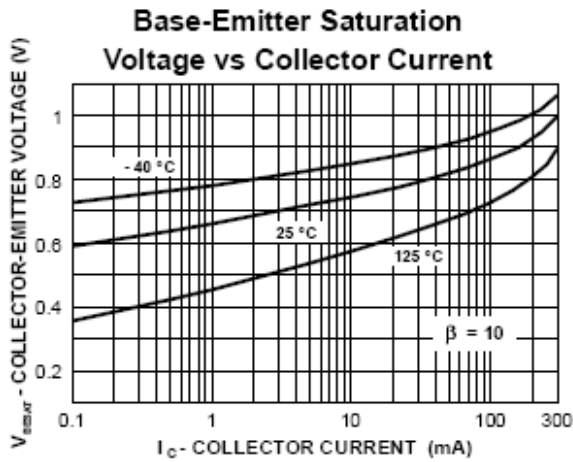

## NPN General Purpose Amplifier

## BCW71/BCW72

### PACKAGE OUTLINE

Plastic surface mounted package

SOT-23

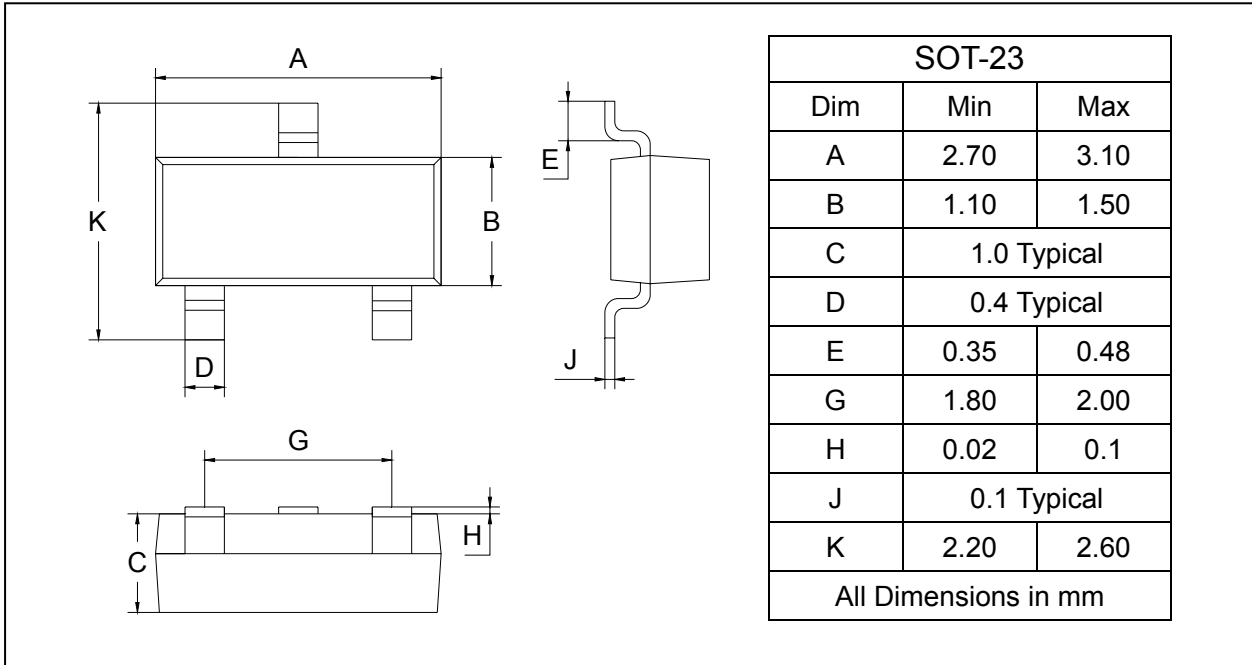

### SOLDERING FOOTPRINT

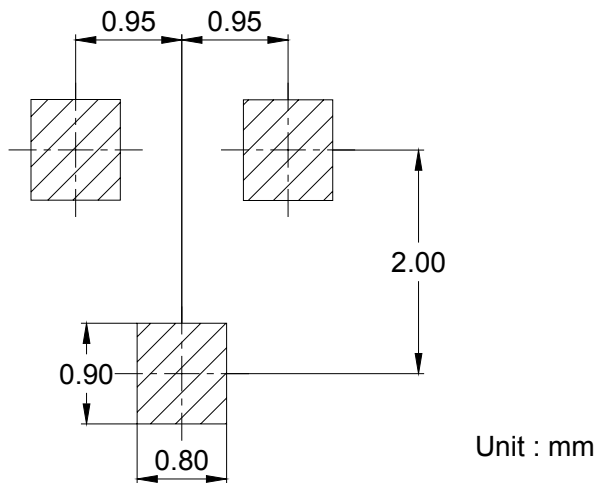

### PACKAGE INFORMATION

Device	Package	Shipping
BCW71/72	SOT-23	3000/Tape&Reel