



Micro Commercial Components

Micro Commercial Components
 20736 Marilla Street Chatsworth
 CA 91311
 Phone: (818) 701-4933
 Fax: (818) 701-4939

Features

- Ideally Suited for Automatic Insertion
- 150°C Junction Temperature
- Low Current, Low Voltage
- For Switching and AF Amplifier applications.
- Suited for low level, low noise, low frequency Applications in hybrid circuits

Mechanical Data

- Case Material: Molded Plastic. UL Flammability Classification Rating 94V-0 and MSL Rating 1
- Terminals: Solderable per MIL-STD-202, Method 208
- Weight: 0.008 grams (approx.)
- Marking :

MCC P/N	Marking	MCC P/N	Marking
BCX70G	AG	BCX70J	AJ
BCX70H	AH	BCX70K	AK

Maximum Ratings @ 25°C Unless Otherwise Specified

Charateristic	Symbol	Value	Unit
Collector-Emitter Voltage	V_{CEO}	45	V
Collector-Base Voltage	V_{CBO}	45	V
Emitter-Base Voltage	V_{EBO}	5	V
Collector Current(DC)	I_C	200	mA
Base Current(DC)	I_B	50	mA
Power Dissipation@ $T_s=79^\circ\text{C}$	P_d	250	mW
Thermal Resistance, Junction to Ambient Air	$R_{\theta JA}$	500 ⁽¹⁾	$^\circ\text{C/W}$
Operating & Storage Temperature	T_j, T_{STG}	-55~150	$^\circ\text{C}$

Notes:

(1) Mounted on FR-4 printed-circuit board

BCX70G THRU BCX70K

NPN Small Signal Transistor 250mW

SOT-23

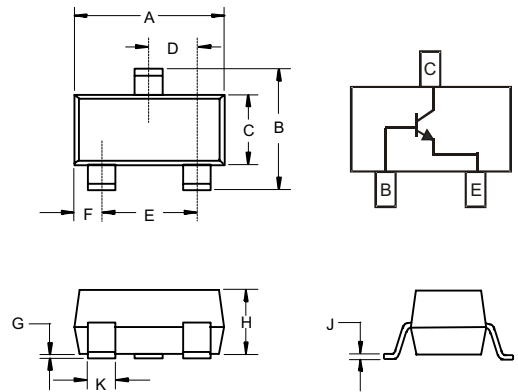

DIM	INCHES		MM		NOTE
	MIN	MAX	MIN	MAX	
A	.110	.120	2.80	3.04	
B	.083	.098	2.10	2.64	
C	.047	.055	1.20	1.40	
D	.035	.041	.89	1.03	
E	.070	.081	1.78	2.05	
F	.018	.024	.45	.60	
G	.0005	.0039	.013	.100	
H	.035	.044	.89	1.12	
J	.003	.007	.085	.180	
K	.015	.020	.37	.51	

Suggested Solder Pad Layout

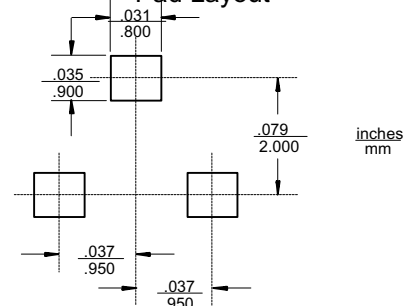

BCX70 Series

Electrical Characteristics (T_J = 25°C unless otherwise noted)

Parameter	Symbol	Test Condition	Min	Typ	Max	Unit
DC Current Gain	BCX70G	V _{CE} = 5 V, I _C = 10 μA	—	—	—	
	BCX70H	V _{CE} = 5 V, I _C = 10 μA	30	—	—	
	BCX70J	V _{CE} = 5 V, I _C = 10 μA	40	—	—	
	BCX70K	V _{CE} = 5 V, I _C = 10 μA	100	—	—	
	BCX70G	V _{CE} = 5 V, I _C = 2 mA	120	—	220	
	BCX70H	V _{CE} = 5 V, I _C = 2 mA	180	—	310	
	BCX70J	V _{CE} = 5 V, I _C = 2 mA	250	—	460	
	BCX70K	V _{CE} = 5 V, I _C = 2 mA	380	—	630	
	BCX70G	V _{CE} = 1 V, I _C = 50 mA	50	—	—	
	BCX70H	V _{CE} = 1 V, I _C = 50 mA	70	—	—	
	BCX70J	V _{CE} = 1 V, I _C = 50 mA	90	—	—	
	BCX70K	V _{CE} = 1 V, I _C = 50 mA	100	—	—	
	Collector-Emitter Saturation Voltage	V _{CEsat}	I _C = 10 mA, I _B = 0.25 mA I _C = 50 mA, I _B = 1.25 mA	50 100	— —	350 550
Base-Emitter Saturation Voltage	V _{BEsat}	I _C = 10 mA, I _B = 0.25 mA I _C = 50 mA, I _B = 1.25 mA	600 700	— —	850 1050	mV
Base-Emitter Voltage	V _{BE}	V _{CE} = 5 V, I _C = 2 mA V _{CE} = 5 V, I _C = 10 μA V _{CE} = 1 V, I _C = 50 mA	550 — —	650 520 780	750 — —	mV
Collector Cut-off Current	I _{CBO}	V _{CB} = 45 V, V _{BE} = 0 V V _{CB} = 45 V, V _{BE} = 0 V T _A = 150°C	— —	— —	20 20	nA μA
Emitter Cut-off Current	I _{EBO}	V _{EB} = 4 V, I _C = 0	—	—	20	nA
Gain-Bandwidth Product	f _T	V _{CE} = 5 V, I _C = 10 mA f = 100 MHz	100	250	—	MHz
Collector-Base Capacitance	C _{CB0}	V _{CB} = 10 V, f = 1 MHz, I _E = 0	—	2.5	—	pF
Emitter-Base Capacitance	C _{EB0}	V _{EB} = 0.5 V, f = 1 MHz, I _C = 0	—	8	—	pF
Noise Figure	F	V _{CE} = 5 V, I _C = 200 μA, R _S = 2 kΩ, f = 1 kHz, B = 200 Hz	—	2	6	dB
Small Signal Current Gain	h _{fe}	V _{CE} = 5 V, I _C = 2 mA, f = 1.0 kHz	— — — —	200 260 330 520		
Turn-on Time at R _L = 990Ω (see fig. 1)	t _{on}	V _{CC} = 10 V, I _C = 10 mA, I _{B(on)} = -I _{B(off)} = 1 mA	—	85	150	ns
Turn-off Time at R _L = 990Ω (see fig. 1)	t _{off}	V _{CC} = 10 V, I _C = 10 mA, I _{B(on)} = -I _{B(off)} = 1 mA	—	480	800	ns



Micro Commercial Components

Ordering Information

Device (Part Number)-TP	Packing Tape&Reel;3Kpcs/Reel
----------------------------	---------------------------------

IMPORTANT NOTICE

Micro Commercial Components Corp. reserves the right to make changes without further notice to any product herein to make corrections, modifications, enhancements, improvements, or other changes. *Micro Commercial Components Corp.* does not assume any liability arising out of the application or use of any product described herein; neither does it convey any license under its patent rights, nor the rights of others. The user of products in such applications shall assume all risks of such use and will agree to hold *Micro Commercial Components Corp.* and all the companies whose products are represented on our website, harmless against all damages.

APPLICATIONS DISCLAIMER

Products offer by *Micro Commercial Components Corp.* are not intended for use in Medical, Aerospace or Military Applications.