

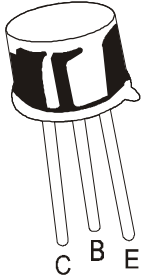

NPN SILICON PLANAR HIGH VOLTAGE TRANSISTOR

BD115



TO-39
Metal Can Package

ABSOLUTE MAXIMUM RATINGS (Ta=25°C unless specified otherwise)

DESCRIPTION	SYMBOL	VALUE	UNITS
Collector Emitter Voltage	V_{CEO}	180	V
Collector Emitter Voltage ($R_{BE} \leq 1KW$)	V_{CER}	245	V
Collector Base Voltage	V_{CBO}	245	V
Emitter Base Voltage	V_{EBO}	5	V
Collector Current Continuous	I_C	150	mA
Peak	I_{CM}	200	mA
Power Dissipation @ Ta=50°C	P_D	6	W
Storage Temperature	T_j, T_{stg}	-55 to +200	°C
THERMAL RESISTANCE			
Junction to Ambient	$R_{th(j-a)}$	25	°C/W

ELECTRICAL CHARACTERISTICS (Ta=25°C unless specified otherwise)

DESCRIPTION	SYMBOL	TEST CONDITION	VALUE			UNITS
			MIN	TYP	MAX	
Collector Emitter Breakdown Voltage	BV_{CEO}	$I_C=1mA, I_B=0$	180			V
Collector Base Breakdown Current	BV_{CBO}	$I_C=100\mu A, I_E=0$	245			V
Emitter Base Breakdown Voltage	B_{VEBO}	$I_E=100\mu A, I_C=0$	5			V
Collector Cutoff Current	I_{CBO}	$V_{CB}=200V, I_E=0$			15	nA
		$V_{CB}=200V, I_E=0, T_j=200^\circ C$		550		μA
Emitter Cutoff Current	I_{EBO}	$V_{EB}=5V, I_C=0$			100	μA
Collector Emitter Saturation Voltage	$V_{CE(Sat)}$ *	$I_C=100mA, I_B=10mA$			3.5	V
Base Emitter On Voltage	$V_{BE(on)}$ *	$I_C=50mA, V_{CE}=100V$			1.0	V
DC Current Gain	h_{FE}	$I_C=50mA, V_{CE}=100V$	22	60		

DYNAMIC CHARACTERISTICS						
DESCRIPTION	SYMBOL	TEST CONDITION	MIN	TYP	MAX	UNITS
Transition Frequency	f_T	$I_C=30mA, V_{CE}=100V$ $f=20MHz$		145		MHz
Collector Base Time Constant	$rb'C_c$	$I_E=10mA, V_{CB}=10V,$ $f=10MHz$		30	100	ps
Feedback Capacitance	C_{re}	$V_{CE}=20V, I_C=10mA,$ $f=1.0MHz$		3.5		pF

*Pulse Test: Pulse Width $\leq 300ms$, Duty Cycle $\leq 2\%$

BD115

**TO-39
Metal Can Package**

TO-39 Metal Can Package

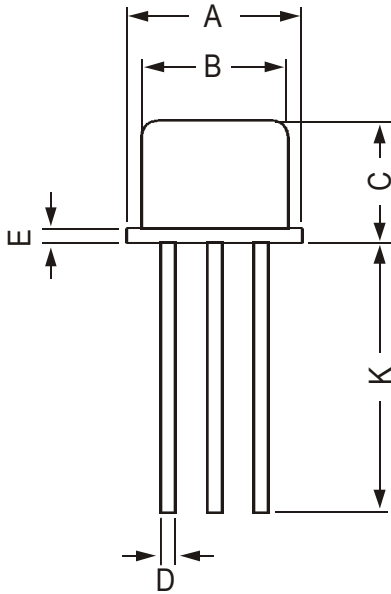

All dimensions are in mm

DIM	MIN	MAX
A	8.50	9.39
B	7.74	8.50
C	6.09	6.60
D	0.40	0.53
E	—	0.88
F	2.41	2.66
G	4.82	5.33
H	0.71	0.86
J	0.73	1.02
K	12.70	—
L	42 DEG	48 DEG

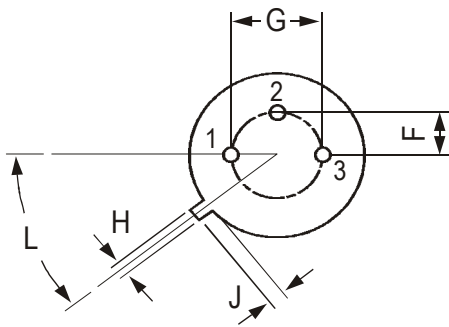

PIN CONFIGURATION
 1. EMITTER
 2. BASE
 3. COLLECTOR

Packing Detail

PACKAGE	STANDARD PACK		INNER CARTON BOX		OUTER CARTON BOX		
	Details	Net Weight/Qty	Size	Qty	Size	Qty	Gr Wt
TO-39	500 pcs/polybag	540 gm/500 pcs	3" x 7.5" x 7.5"	20K	17" x 15" x 13.5"	32K	40 kgs