

Silicon PNP Power Transistors

BD132

DESCRIPTION

www.dataSheet4U.com

- Complement to type BD131
- With TO-126 package
- High current (Max:- 3A)
- Low voltage (Max: -45V)

APPLICATIONS

- For general purpose power applications

PINNING

PIN	DESCRIPTION
1	Emitter
2	Collector;connected to mounting base
3	Base

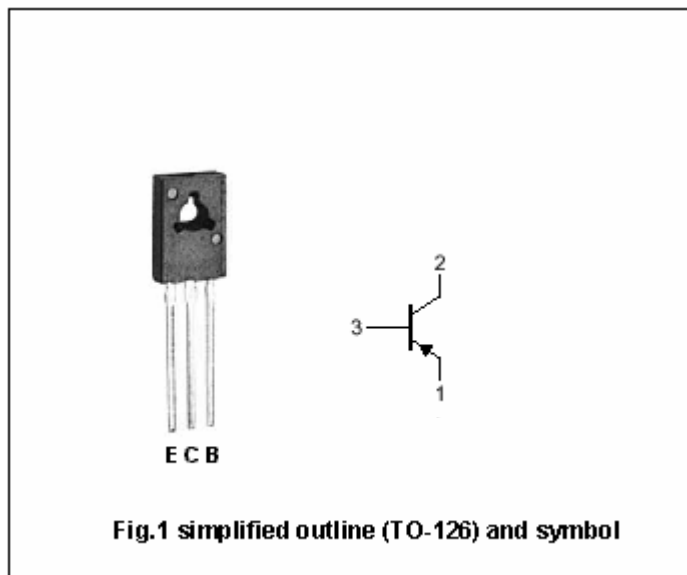

Absolute maximum ratings (Ta=25°C)

SYMBOL	PARAMETER	CONDITIONS	VALUE	UNIT
V _{CBO}	Collector-base voltage	Open emitter	-45	V
V _{CEO}	Collector-emitter voltage	Open base	-45	V
V _{EBO}	Emitter -base voltage	Open collector	-4	V
I _C	Collector current (DC)		-3	A
I _{CM}	Collector current-Peak		-6	A
I _{BM}	Base current-Peak		-0.5	A
P _t	Total power dissipation	T _{mb} ≤60°C	15	W
T _j	Junction temperature		150	°C
T _{stg}	Storage temperature		-65~150	°C

THERMAL CHARACTERISTICS

SYMBOL	PARAMETER	VALUE	UNIT
R _{th j-a}	Thermal resistance from junction to ambient	100	K/W
R _{th j-mb}	Thermal resistance from junction to mounting base	6	K/W

Silicon PNP Power Transistors

BD132

CHARACTERISTICS

T_j=25°C unless otherwise specified

www.datasheet4u.com

SYMBOL	PARAMETER	CONDITIONS	MIN	TYP.	MAX	UNIT
V _{CEsat-1}	Collector-emitter saturation voltage	I _C =-0.5A; I _B =-50mA			-0.3	V
V _{CEsat-2}	Collector-emitter saturation voltage	I _C =-2A; I _B =-0.2A			-0.7	V
V _{BEsat-1}	Base-emitter saturation voltage	I _C =-0.5A; I _B =-50mA			-1.2	V
V _{BEsat-2}	Base-emitter saturation voltage	I _C =-2A; I _B =-0.2A			-1.5	V
I _{CBO}	Collector cut-off current	V _{CB} =-50V; I _E =0			-50	nA
		V _{CB} =-50V; I _E =0 T _j =150°C			-10	μA
I _{EBO}	Emitter cut-off current	V _{EB} =-5V; I _C =0			-50	nA
h _{FE-1}	DC current gain	I _C =-0.5A; V _{CE} =-12V	40			
h _{FE-2}	DC current gain	I _C =-2A; V _{CE} =-1V	20			
f _T	Transition frequency	I _C =-0.25A; V _{CE} =-5V; f=100MHz	60			MHz

Silicon PNP Power Transistors

BD132

PACKAGE OUTLINE

www.datasheet4u.com

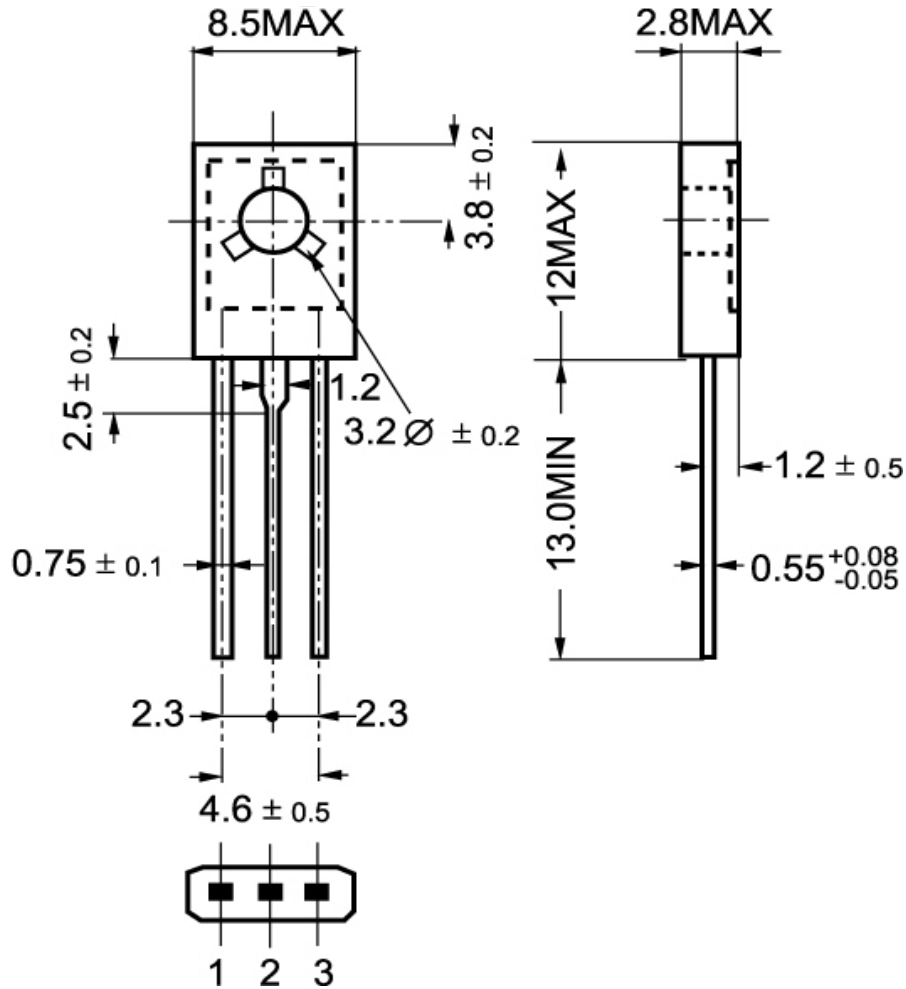

Fig.2 Outline dimensions