

2ch High Side Switch ICs

# 2.4A Current Limit High Side Switch ICs

**BD2068FJ-M BD2069FJ-M**

**General Description**

BD2068FJ-M and BD2069FJ-M are dual channel high side switch ICs with an over-current protection for of Universal Serial Bus (USB) power supply line. Its switch unit has two channels of N-Channel power MOSFET. Over current detection circuit, thermal shutdown circuit, under-voltage lockout, and soft-start circuit are built in.

**Key Specifications**

- Input Voltage Range: 2.7V to 5.5V
- ON-Resistance: 80mΩ(Typ)
- Continuous Current Load 1.0A
- Current Limit Threshold: 1.5A (Min), 3.0A (Max)
- Standby Current: 0.01μA (Typ)
- Output Rise Time: 0.8ms(Typ)
- Operating Temperature Range: -40°C to +85°C

**Features**

- AEC-Q100 Qualified<sup>(Note 1)</sup>
  - Built-in Dual Low ON-Resistance N-channel MOSFET(Typ 80mΩ)
  - Control Input Logic
    - Active-High : BD2068FJ-M
    - Active-Low: BD2069FJ-M
  - Soft-Start Circuit
  - Over Current Detection
  - Thermal Shutdown
  - Under-Voltage Lockout
  - Open-Drain Error Flag Output
  - Reverse Current Protection when Power Switch Off
  - Flag Output Delay Filter Built In
- (Note 1: Grade3)

**Package**

W(Typ) D(Typ) H (Max)

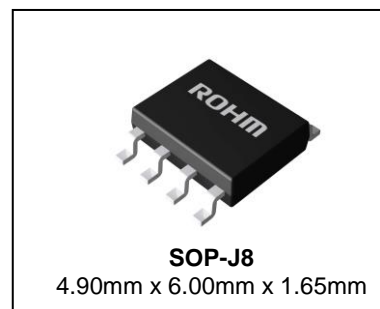

**Applications**

Car accessory

**Typical Application Circuit**

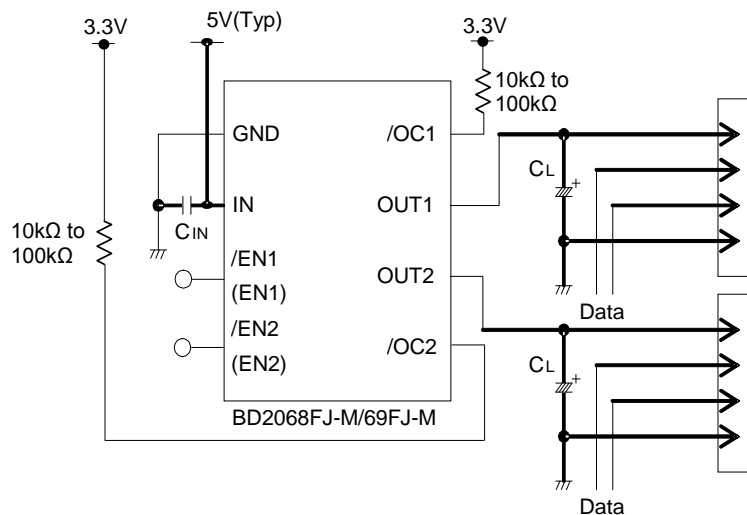

**Lineup**

Current Limit Threshold			Control Input Logic	Package		Orderable Part Number
Min	Typ	Max				
1.5A	2.4A	3.0A	High	SOP-J8	Reel of 2500	BD2068FJ-MGE2
1.5A	2.4A	3.0A	Low	SOP-J8	Reel of 2500	BD2069FJ-MGE2

○Product structure : Silicon monolithic integrated circuit ○This product has not designed protection against radioactive rays

Block Diagram

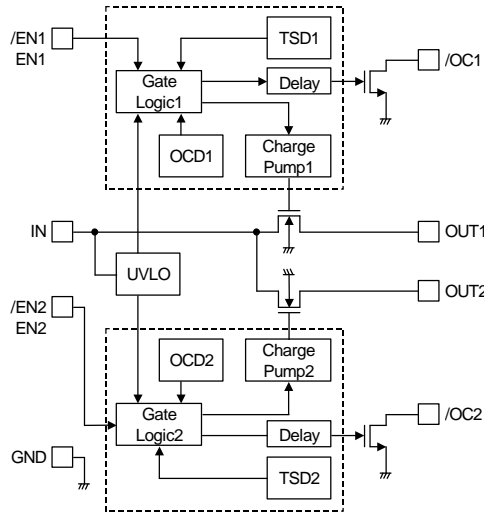

Pin Configurations

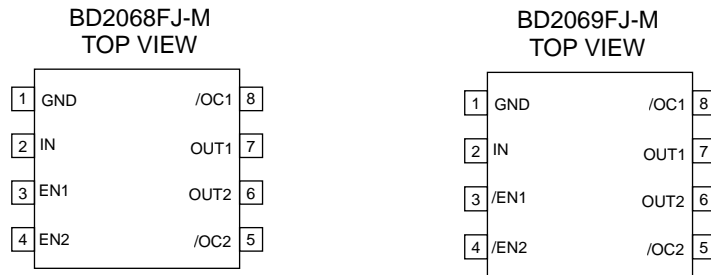

Pin Description

Pin No.	Symbol	I / O	Pin Function
1	GND	-	Ground.
2	IN	-	Power supply input. Input terminal to the switch and power supply input terminal of the internal circuit.
3, 4	EN1, /EN1 EN2, /EN2	I	Enable input. EN1, EN2: Switch on at high level. (BD2068FJ-M) /EN1, /EN2: Switch on at low level. (BD2069FJ-M) High level input > 2.0V, low level input < 0.8V.
5, 8	/OC1, /OC2	O	Error flag output. Low at over-current, thermal shutdown. Open drain output.
6, 7	OUT1, OUT2	O	Switch output.

## Absolute Maximum Ratings (Ta=25°C)

Parameter	Symbol	Rating	Unit
Supply Voltage	V <sub>IN</sub>	-0.3 to +6.0	V
Enable Input Voltage	V <sub>EN</sub> , V <sub>/EN</sub>	-0.3 to +6.0	V
/OC Voltage	V <sub>/OC</sub>	-0.3 to +6.0	V
/OC Sink Current	I <sub>/OC</sub>	5	mA
OUT Voltage	V <sub>OUT</sub>	-0.3 to +6.0	V
Storage Temperature	T <sub>stg</sub>	-55 to +150	°C
Power Dissipation	P <sub>d</sub>	0.67 <sup>(Note 1)</sup>	W

(Note 1) Mounted on 70mm x 70mm x 1.6mm glass-epoxy PCB. Reduce 5.4mW/°C above Ta=25°C

**Caution:** Operating the IC over the absolute maximum ratings may damage the IC. The damage can either be a short circuit between pins or an open circuit between pins and the internal circuitry. Therefore, it is important to consider circuit protection measures, such as adding a fuse, in case the IC is operated over the absolute maximum ratings.

## Recommended Operating Conditions

Parameter	Symbol	Rating			Unit
		Min	Typ	Max	
Operating Voltage	V <sub>IN</sub>	2.7	-	5.5	V
Operating Temperature	T <sub>opr</sub>	-40	-	+85	°C

## Electrical Characteristics

BD2068FJ-M (Unless otherwise specified V<sub>IN</sub> = 5.0V, Ta = 25°C)

Parameter	Symbol	Limit			Unit	Conditions
		Min	Typ	Max		
Operating Current	I <sub>DD</sub>	-	130	180	μA	V <sub>EN</sub> = 5V, OUT=OPEN
Standby Current	I <sub>STB</sub>	-	0.01	1	μA	V <sub>EN</sub> = 0V, OUT=OPEN
EN Input Voltage	V <sub>EN</sub>	2.0	-	-	V	High Input
	V <sub>/EN</sub>	-	-	0.8	V	Low Input
EN Input Current	I <sub>EN</sub>	-1.0	+0.01	+1.0	μA	V <sub>EN</sub> = 0V or V <sub>EN</sub> = 5V
/OC Output Low Voltage	V <sub>/OCL</sub>	-	-	0.5	V	I <sub>/OC</sub> = 1mA
/OC Output Leak Current	I <sub>L/OC</sub>	-	0.01	1	μA	V <sub>/OC</sub> = 5V
/OC Delay Time	t <sub>/OC</sub>	10	15	20	ms	
ON-Resistance	R <sub>ON</sub>	-	80	125	mΩ	I <sub>OUT</sub> = 500mA
Switch Leak Current	I <sub>LSW</sub>	-	-	1.0	μA	V <sub>EN</sub> = 0V, V <sub>OUT</sub> = 0V
Reverse Leak Current	I <sub>LREV</sub>	-	-	1.0	μA	V <sub>OUT</sub> = 5.5V, V <sub>IN</sub> = 0V
Current Limit Threshold	I <sub>TH</sub>	1.5	2.4	3.0	A	
Short Circuit Current	I <sub>SC</sub>	1.1	1.5	2.1	A	V <sub>OUT</sub> = 0V C <sub>L</sub> = 47μF (RMS)
Output Rise Time	t <sub>ON1</sub>	-	0.8	10	ms	R <sub>L</sub> = 10Ω
Output Turn-ON Time	t <sub>ON2</sub>	-	1.1	20	ms	R <sub>L</sub> = 10Ω
Output Fall Time	t <sub>OFF1</sub>	-	5	20	μs	R <sub>L</sub> = 10Ω
Output Turn-OFF Time	t <sub>OFF2</sub>	-	10	40	μs	R <sub>L</sub> = 10Ω
UVLO Threshold	V <sub>TUVH</sub>	2.1	2.3	2.5	V	V <sub>IN</sub> Increasing
	V <sub>TUVL</sub>	2.0	2.2	2.4	V	V <sub>IN</sub> Decreasing

## Electrical Characteristics - continued

BD2069FJ-M (Unless otherwise specified  $V_{IN} = 5.0V$ ,  $T_a = 25^\circ C$ )

Parameter	Symbol	Limit			Unit	Conditions
		Min	Typ	Max		
Operating Current	$I_{DD}$	-	130	180	$\mu A$	$V_{EN} = 0V$ , OUT=OPEN
Standby Current	$I_{STB}$	-	0.01	1	$\mu A$	$V_{EN} = 5V$ , OUT=OPEN
/EN Input Voltage	$V_{/EN}$	2.0	-	-	V	High Input
	$V_{/EN}$	-	-	0.8	V	Low Input
/EN Input Current	$I_{/EN}$	-1.0	+0.01	+1.0	$\mu A$	$V_{/EN} = 0V$ or $V_{/EN} = 5V$
/OC Output Low Voltage	$V_{/OCL}$	-	-	0.5	V	$I_{/OC} = 1mA$
/OC Output Leak Current	$I_{/OC}$	-	0.01	1	$\mu A$	$V_{/OC} = 5V$
/OC Delay Time	$t_{/OC}$	10	15	20	ms	
ON-Resistance	$R_{ON}$	-	80	125	m $\Omega$	$I_{OUT} = 500mA$
Switch Leak Current	$I_{LSW}$	-	-	1.0	$\mu A$	$V_{EN} = 5V$ , $V_{OUT} = 0V$
Reverse Leak Current	$I_{LREV}$	-	-	1.0	$\mu A$	$V_{OUT} = 5.5V$ , $V_{IN} = 0V$
Current Limit Threshold	$I_{TH}$	1.5	2.4	3.0	A	
Short Circuit Current	$I_{SC}$	1.1	1.5	2.1	A	$V_{OUT} = 0V$ $C_L = 47\mu F$ (RMS)
Output Rise Time	$t_{ON1}$	-	0.8	10	ms	$R_L = 10\Omega$
Output Turn-ON Time	$t_{ON2}$	-	1.1	20	ms	$R_L = 10\Omega$
Output Fall Time	$t_{OFF1}$	-	5	20	$\mu s$	$R_L = 10\Omega$
Output Turn-OFF Time	$t_{OFF2}$	-	10	40	$\mu s$	$R_L = 10\Omega$
UVLO Threshold	$V_{TUVH}$	2.1	2.3	2.5	V	$V_{IN}$ Increasing
	$V_{TUVL}$	2.0	2.2	2.4	V	$V_{IN}$ Decreasing

Measurement Circuit

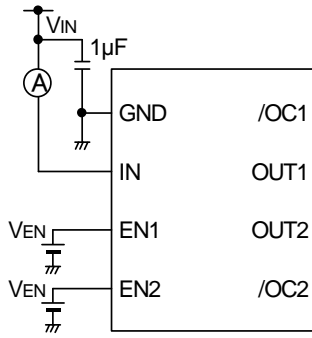

A. Operating Current

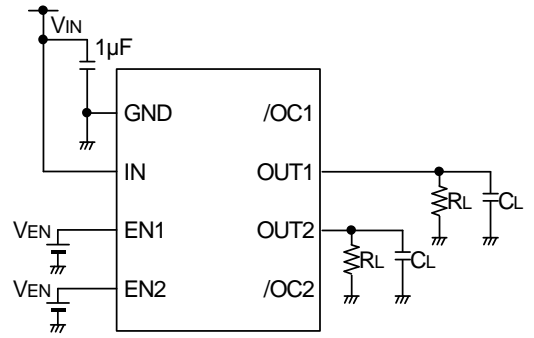

B. EN, /EN Input Voltage, Output Rise / Fall Time Inrush Current

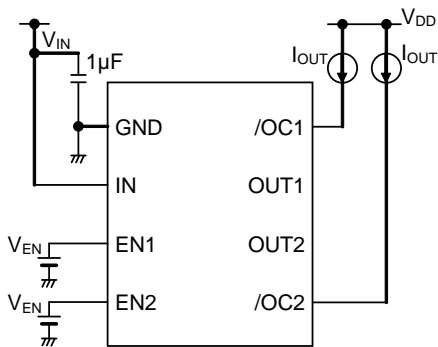

C. ON-Resistance, Over Current Detection

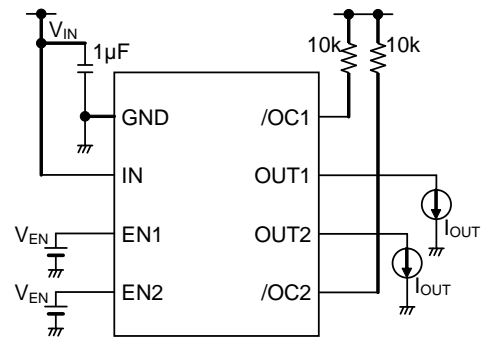

D. /OC Output Low Voltage

Figure 1. Measurement Circuit

Timing Diagram

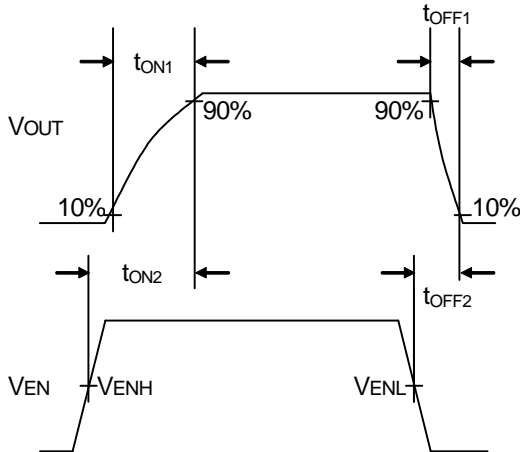

Figure 2. Timing Diagram(BD2068FJ-M)

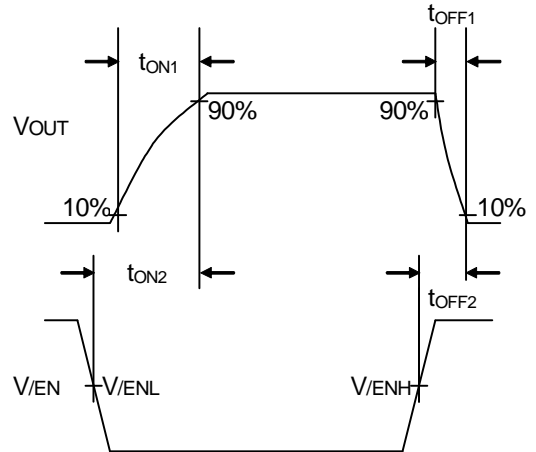

Figure 3. Timing Diagram(BD2069FJ-M)

Typical Performance Curves

(Reference Data)

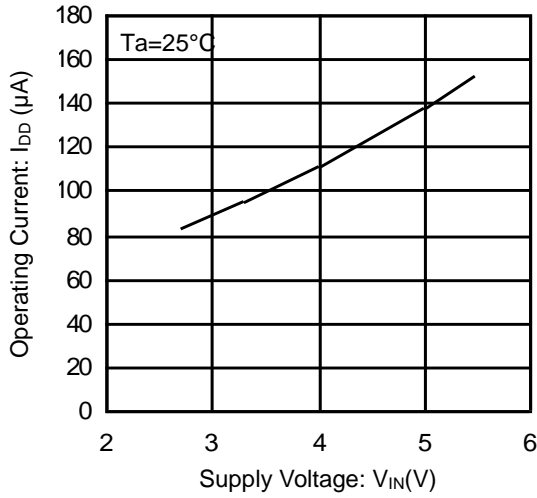

Figure 4. Operating Current vs Supply Voltage (EN, /EN Enable)

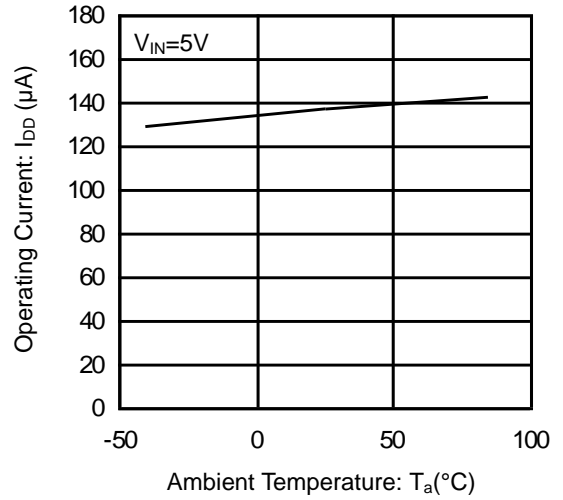

Figure 5. Operating Current vs Ambient Temperature (EN, /EN Enable)

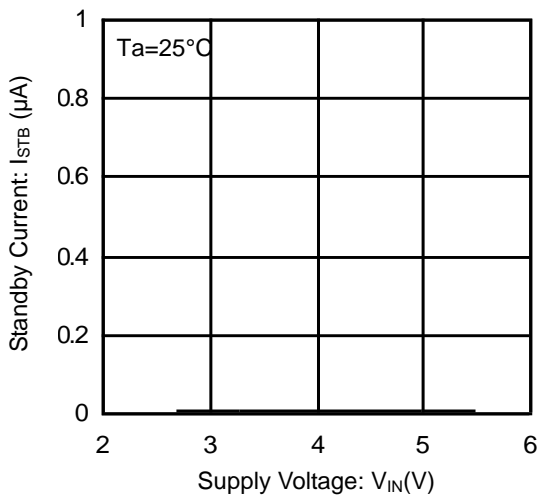

Figure 6. Standby Current vs Supply Voltage (EN, /EN Disable)

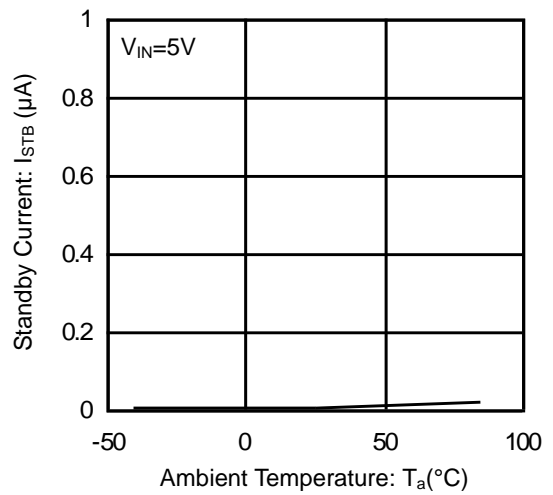

Figure 7. Standby Current vs Ambient Temperature (EN, /EN Disable)

Typical Performance Curves - continued

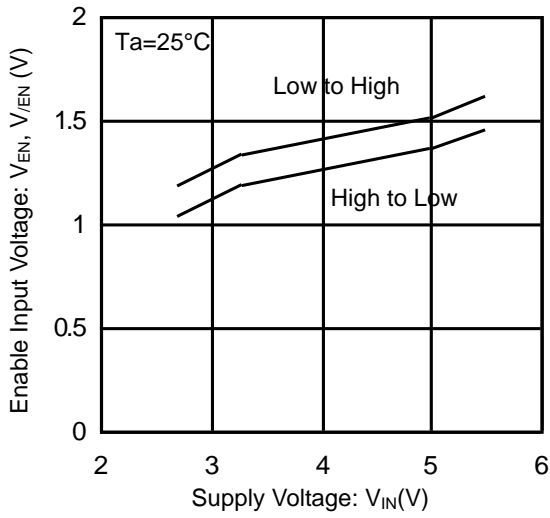

Figure 8. EN, /EN Input Voltage vs Supply Voltage (EN1, EN2, /EN1, /EN2)

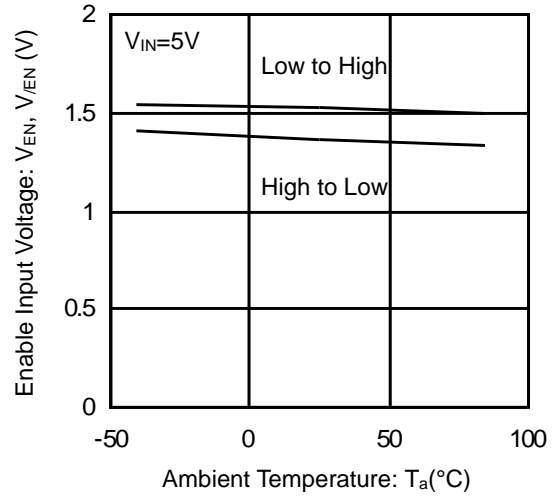

Figure 9. EN, /EN Input Voltage vs Ambient Temperature (EN1, EN2, /EN1, /EN2)

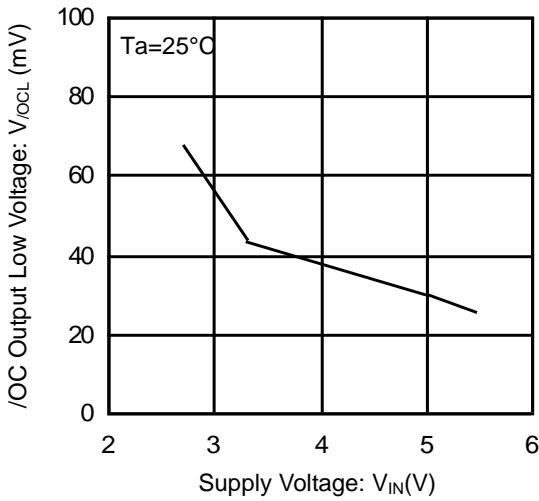

Figure 10. /OC Output Low Voltage vs Supply Voltage

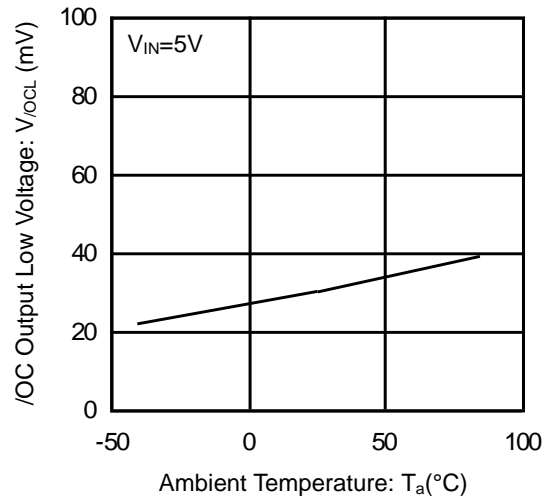

Figure 11. /OC Output Low Voltage vs Ambient Temperature

Typical Performance Curves - continued

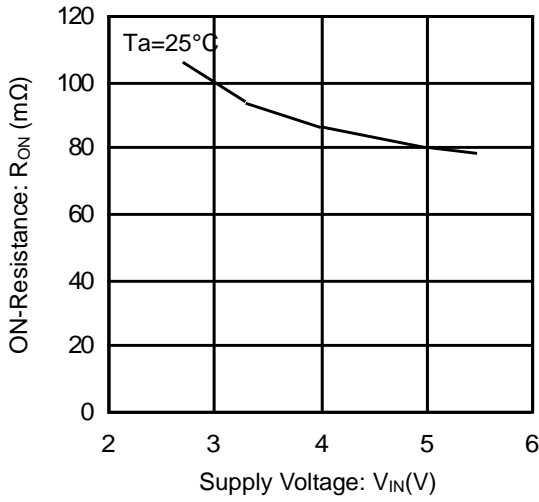

Figure 12. ON-Resistance vs Supply Voltage

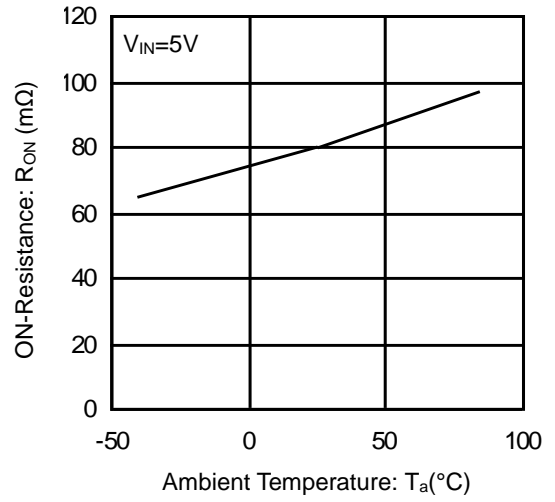

Figure 13. ON-Resistance vs Ambient Temperature

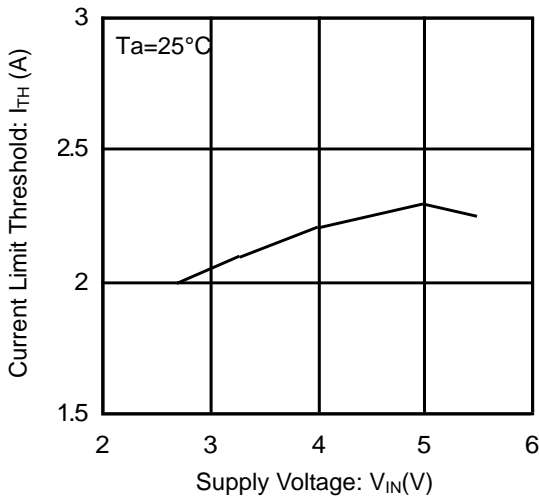

Figure 14. Current Limit Threshold vs Supply Voltage

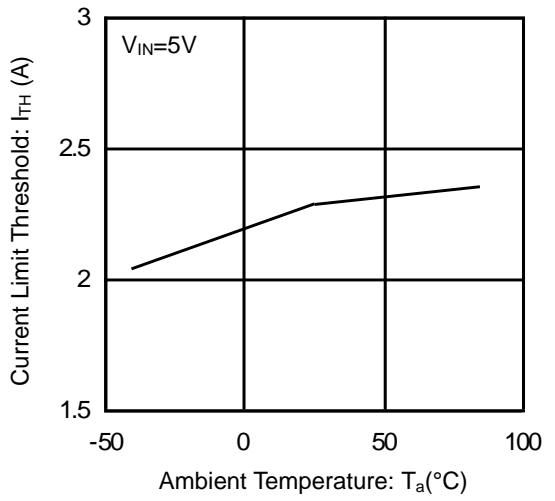

Figure 15. Current Limit Threshold vs Ambient Temperature



Typical Performance Curves - continued

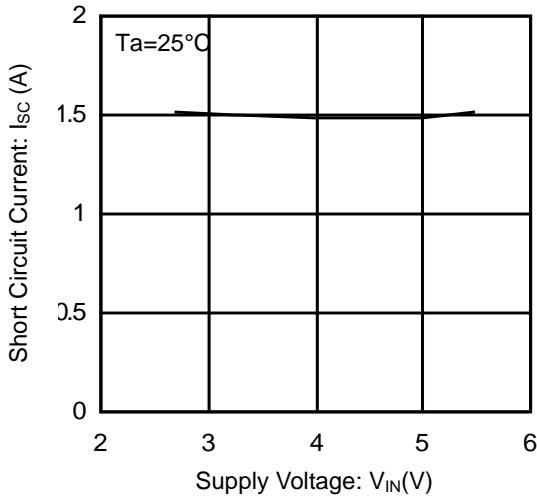

Figure 16. Short Circuit Current vs Supply Voltage

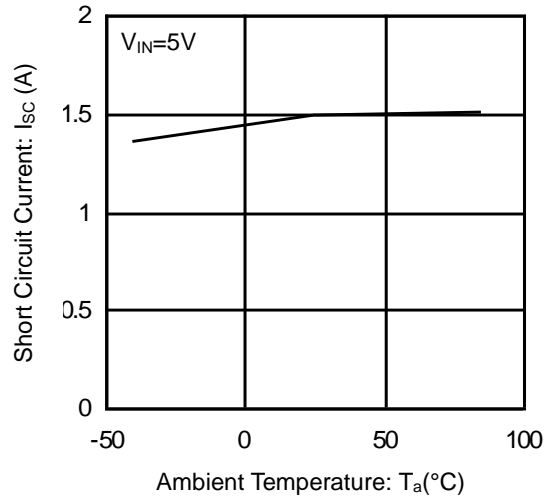

Figure 17. Short Circuit Current vs Ambient Temperature

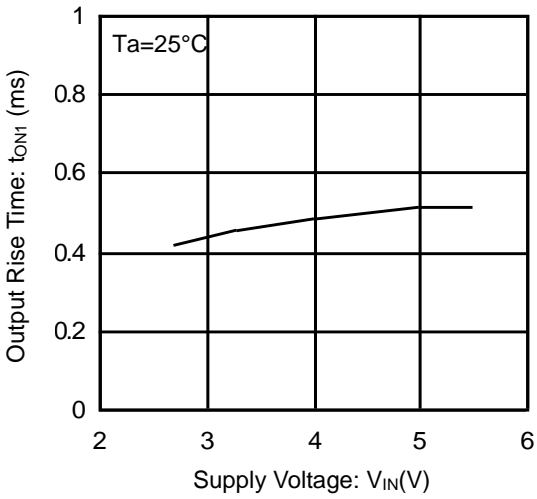

Figure 18. Output Rise Time vs Supply Voltage

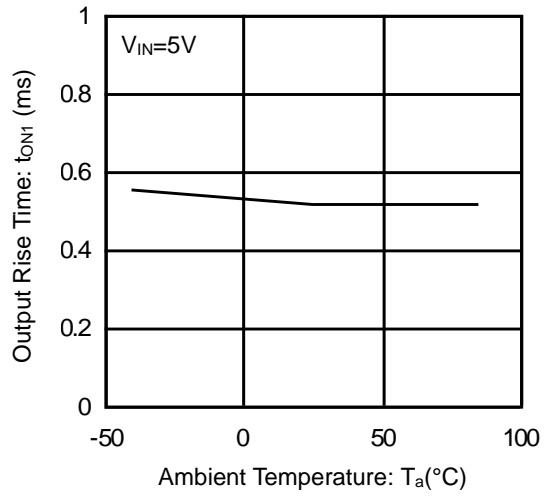

Figure 19. Output Rise Time vs Ambient Temperature

Typical Performance Curves - continued

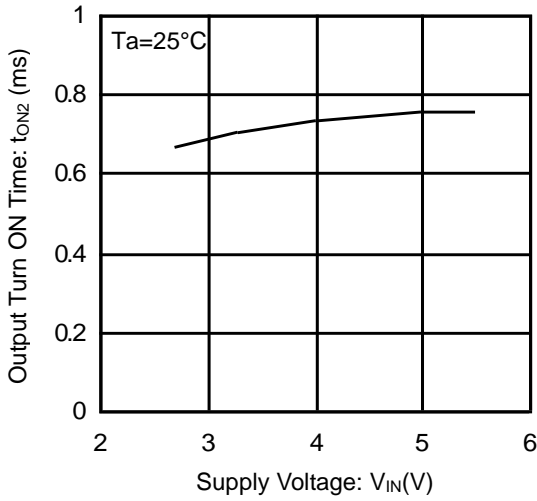

Figure 20. Output Turn ON Time vs Supply Voltage

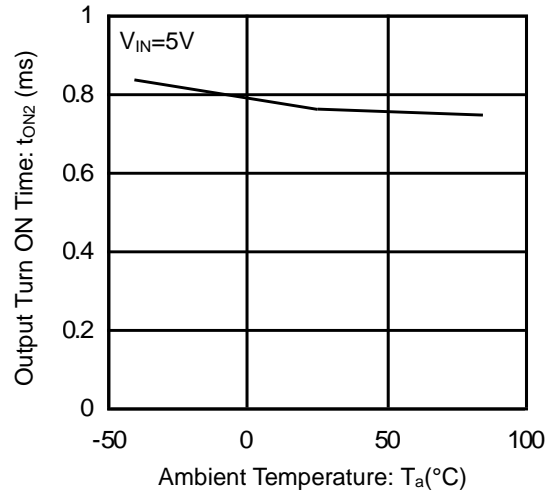

Figure 21. Output Turn ON Time vs Ambient Temperature

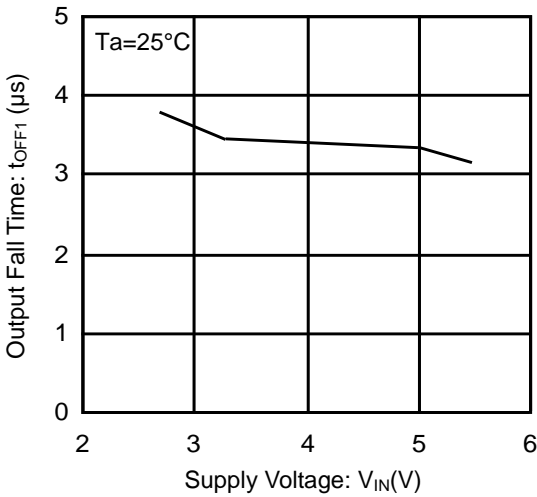

Figure 22. Output Fall Time vs Supply Voltage

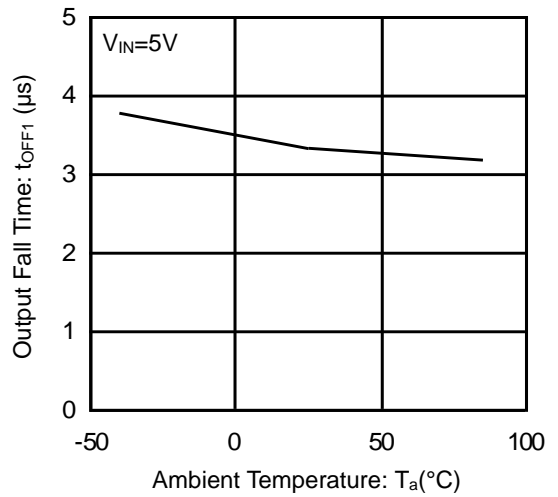

Figure 23. Output Fall Time vs Ambient Temperature

Typical Performance Curves - continued

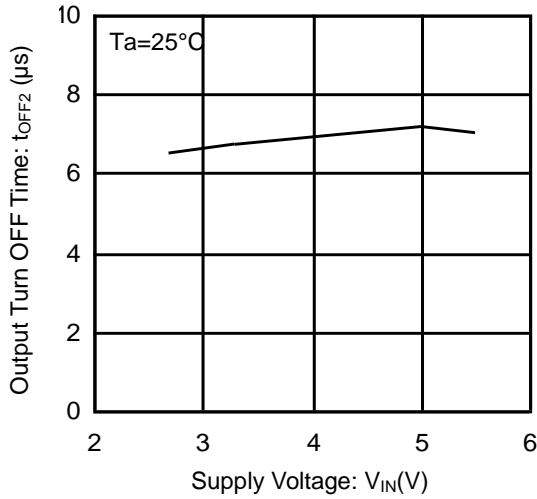

Figure 24. Output Turn OFF Time vs Supply Voltage

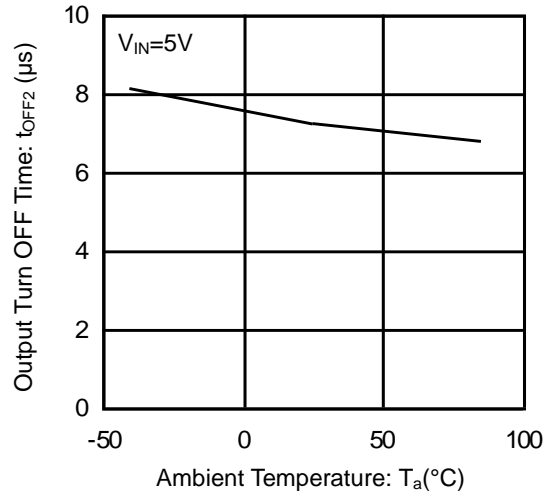

Figure 25. Output Turn OFF Time vs Ambient Temperature

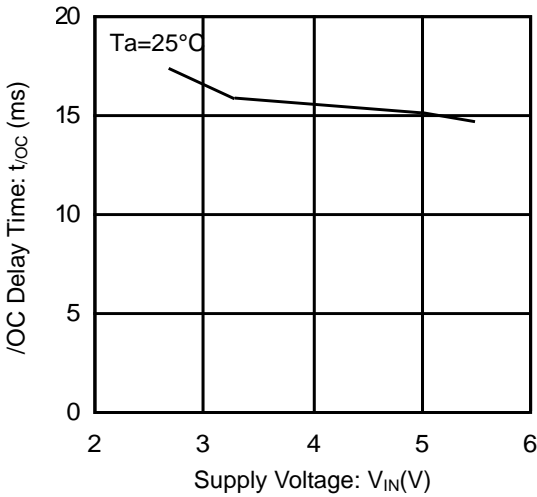

Figure 26. /OC Delay Time vs Supply Voltage

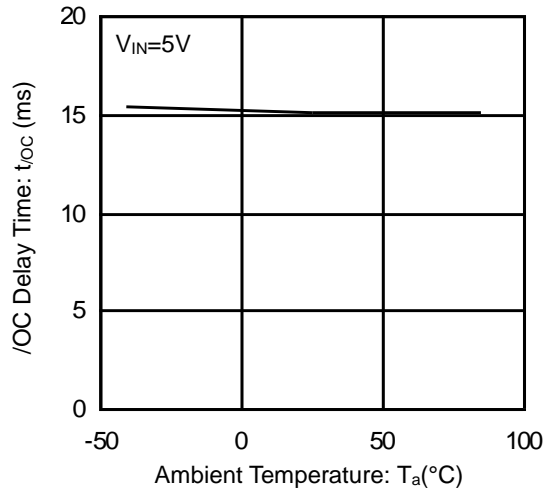

Figure 27. /OC Delay Time vs Ambient Temperature

Typical Performance Curves - continued

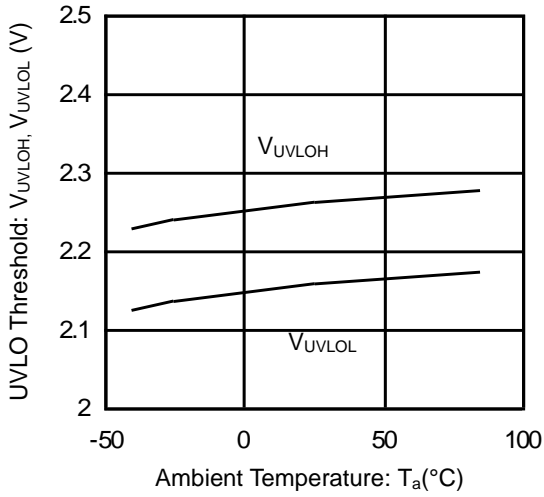

Figure 28. UVLO Threshold Voltage vs Ambient Temperature

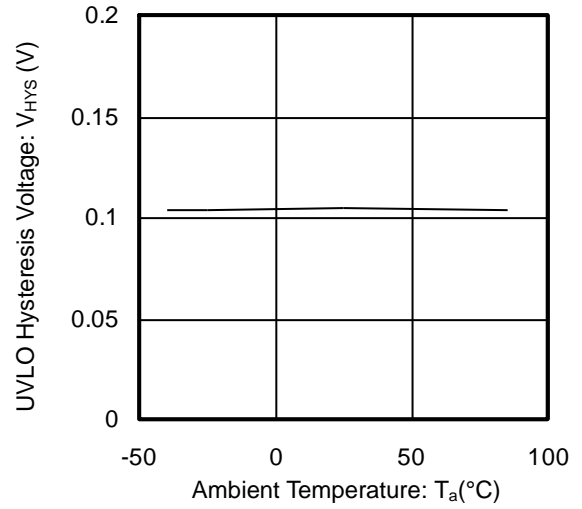

Figure 29. UVLO Hysteresis Voltage vs Ambient Temperature

Typical Wave Forms

BD2069FJ-M

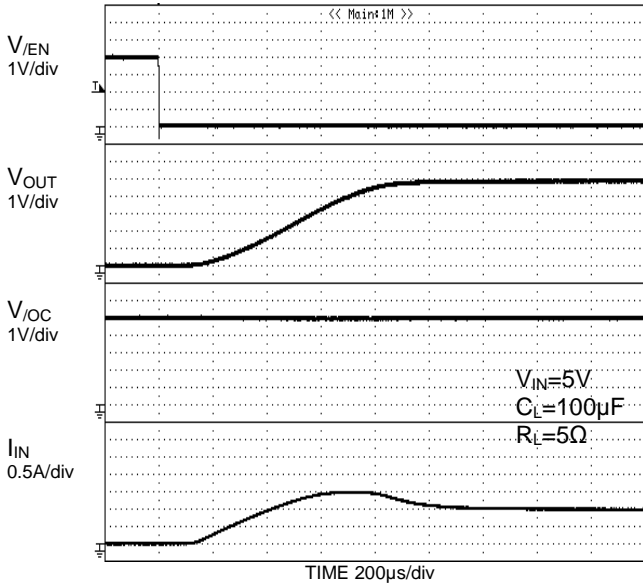

Figure 30. Output Rise Characteristics

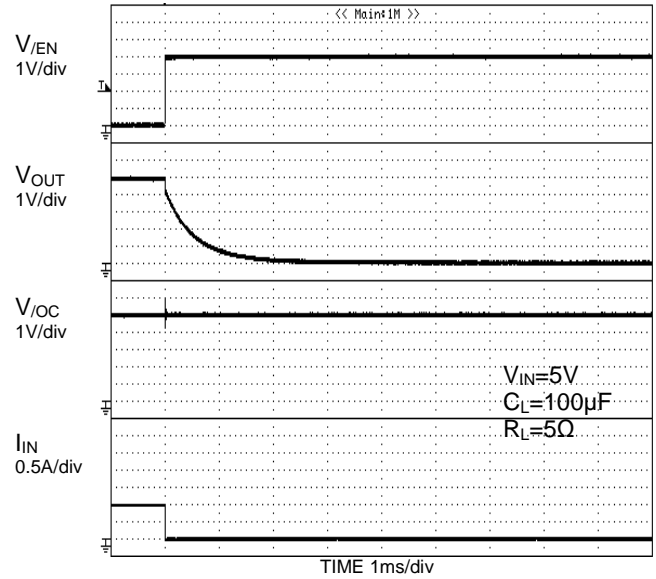

Figure 31. Output Fall Characteristics

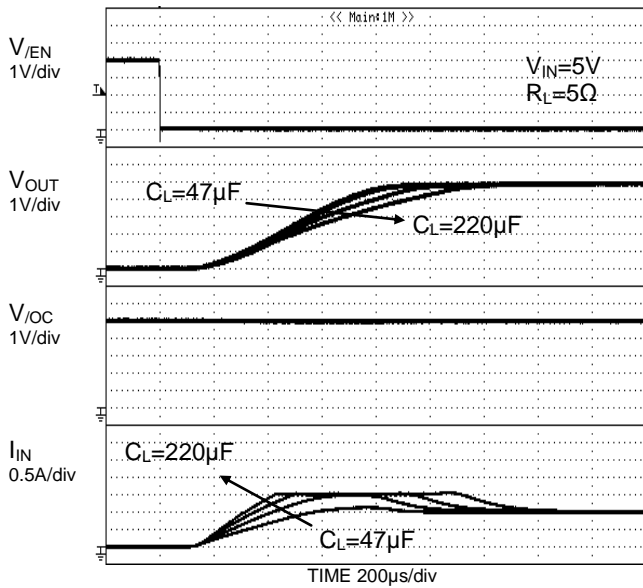

Figure 32. Inrush Current  
 $C_L=47\mu\text{F}$ ,  $100\mu\text{F}$ ,  $147\mu\text{F}$ ,  $220\mu\text{F}$

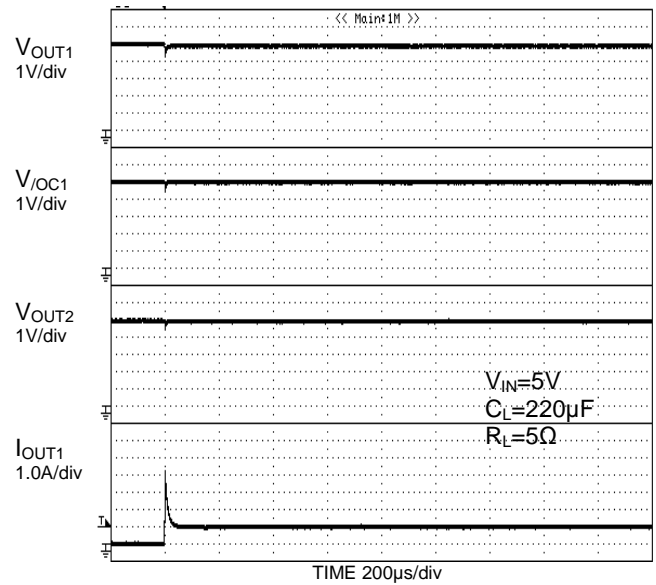

Figure 33. Inrush Current

Typical Wave Forms - continued

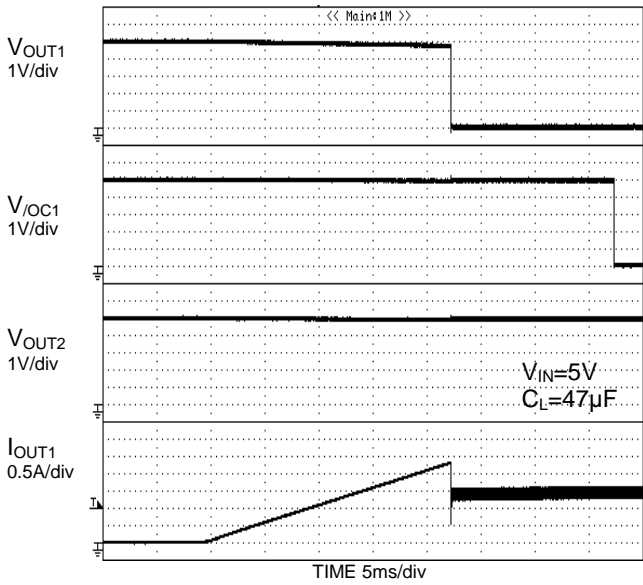

Figure 34. Over-Current Response Ramped Load

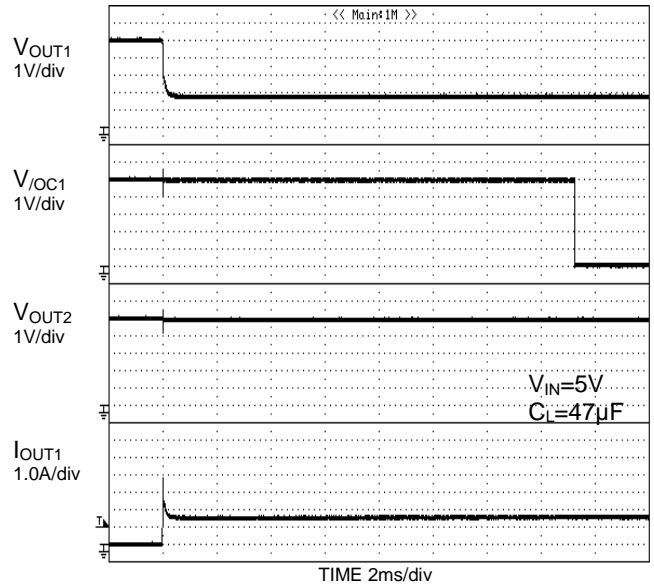

Figure 35. Over-Current Response 1Ω Load Connected at Enable

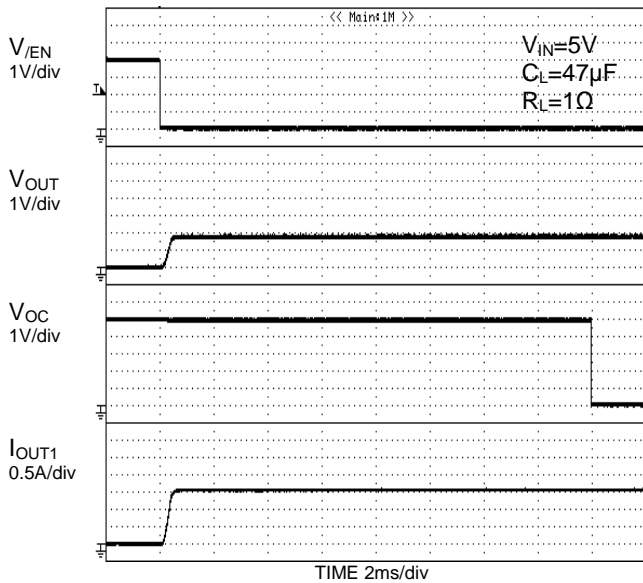

Figure 36. Over-Current Response Enable to Short Circuit

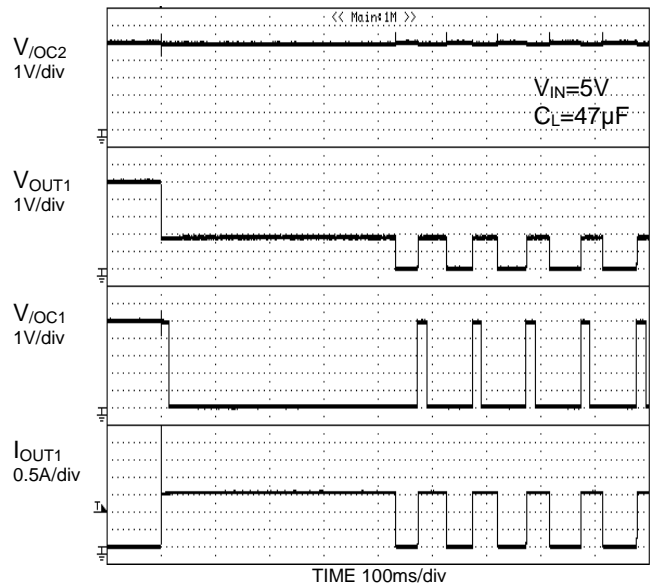
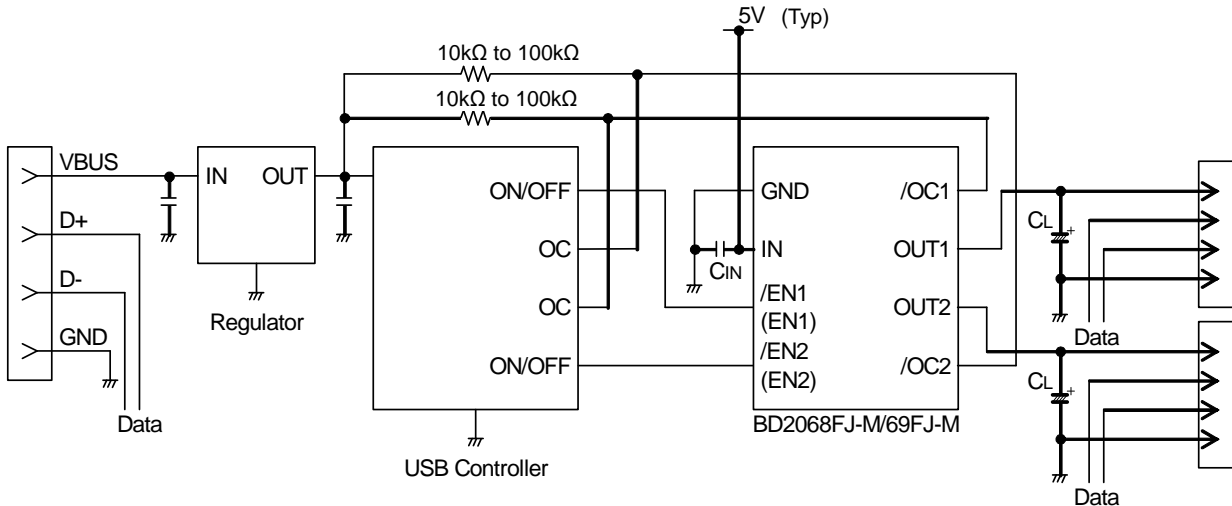

Figure 37. Thermal Shutdown Response

## Typical Application Circuit



## Application Information

When excessive current flows due to output short circuit or so, ringing occurs by inductance between power source line and IC. This may cause bad effects on IC operations. In order to avoid this case, a bypass capacitor ( $C_{IN}$ ) should be connected across IN terminal and GND terminal of IC.  $1\mu\text{F}$  or higher is recommended.

Pull up /OC output by a resistance value of  $10\text{k}\Omega$  to  $100\text{k}\Omega$ .

Set up values of  $C_L$  which satisfies the application.

This application circuit does not guarantee its operation.

When using the circuit with changes to the external circuit constants, make sure to leave an adequate margin for external components including AC/DC characteristics as well as dispersion of the IC.

## Functional Description

### 1. Switch Operation

IN terminal and OUT terminal are connected to the drain and the source of switch MOSFET respectively. The IN terminal is also used as power source input to internal control circuit.

When the switch is turned on from EN(/EN) control input, IN and OUT terminals are connected by a  $80\text{m}\Omega$  switch. In on status, the switch is bidirectional. Therefore, when the potential of OUT terminal is higher than that of IN terminal, current flows from OUT to IN terminal. On the other hand, when the switch is turned off, it is possible to prevent current from flowing reversely from OUT to IN terminal since a parasitic diode between the drain and the source of switch MOSFET is not present.

### 2. Thermal Shutdown Circuit (TSD)

Thermal shut down circuit have a dual thermal shutdown threshold. Since thermal shutdown works at a lower junction temperature when an over-current occurs, the switch turns off and outputs an error flag (/OC).

Thermal shut down action has hysteresis. When the junction temperature goes down the switch automatically turns on and resets the error flag. Unless the cause of increase of the chip's temperature is removed or the output of power switch is turned off, this operation repeats. The thermal shut down circuit works when the switch of either OUT1 or OUT2 is on (EN, /EN signal is active).

3. Over-Current Detection (OCD)

The over-current detection circuit limits current ( $I_{SC}$ ) and outputs error flag (/OC) when current flowing in each switch MOSFET exceeds a specified value. The over-current detection circuit works when the switch is on (EN, (/EN) signal is active). There are three types of response against over-current:

- (1) When the switch is turned on while the output is in short circuit status, the switch goes into current limit status immediately.
- (2) When the output short-circuits or a high capacity load is connected while the switch is on, very large current flows until the over-current limit circuit reacts. When the current detection and limit circuit operates, current limitation is carried out.
- (3) When the output current increases gradually, current limitation would not operate unless the output current exceeds the over-current detection value. When it exceeds the detection value, current limitation is carried out.

4. Under-Voltage Lockout (UVLO)

UVLO circuit prevents the switch from turning on until the  $V_{IN}$  exceeds 2.3V(Typ). If  $V_{IN}$  drops below 2.2V(Typ) while the switch is still ON, then UVLO shuts off the power switch. UVLO has a hysteresis of 100mV(Typ).

Note: Under-voltage lockout circuit operates when the switch of either OUT1 or OUT2 is on (EN,/EN signal is active).

5. Fault Flag (/OC) Output

Fault flag output is N-MOS open drain output. During detection of over-current and/or thermal shutdown, the output level will turn low.

Over current detection has delay filter. This delay filter prevents current detection flags from being sent during instantaneous events such as inrush current at switch on or during hot plug. If fault flag output is unused, /OC pin should be connected to ground line or open.

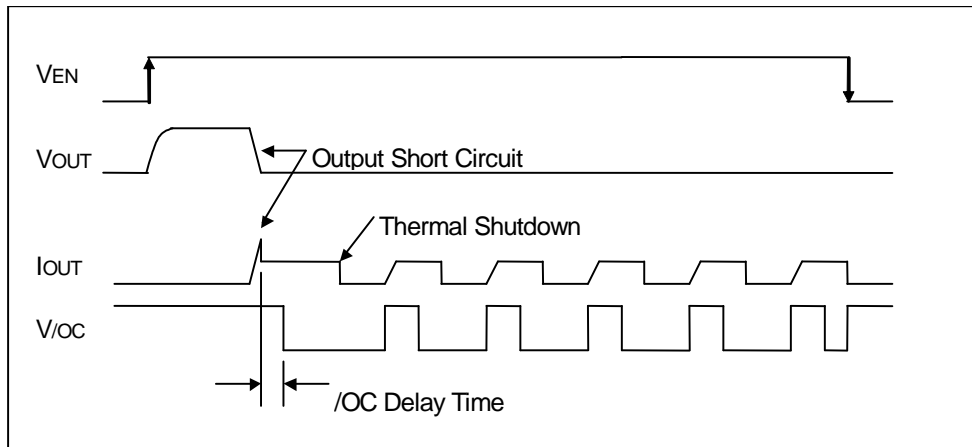

Figure 38. Over Current Detection, Thermal Shutdown Timing (BD2068FJ-M)

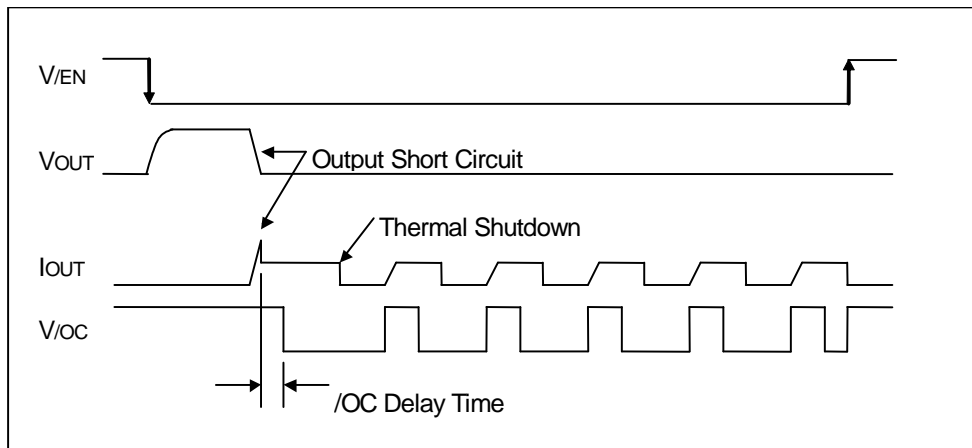
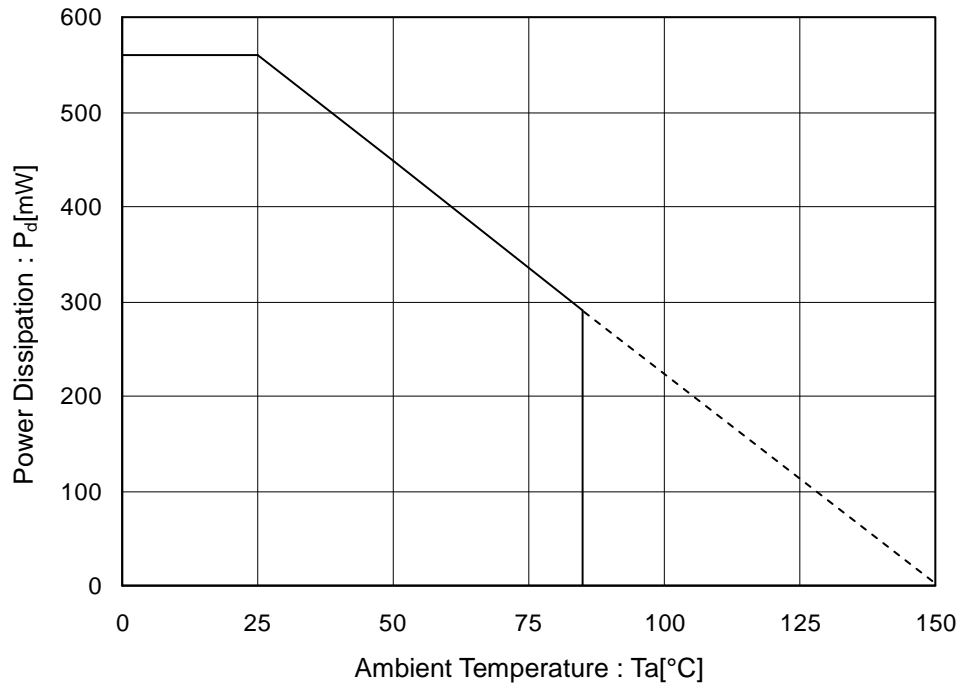

Figure 39. Over Current Detection, Thermal Shutdown Timing (BD2069FJ-M)



Power Dissipation

(SOP-J8)



Mounted on 70mm x 70mm x 1.6mm glass-epoxy PCB.

Figure 40. Power Dissipation Curve (Pd-Ta Curve)

I/O Equivalence Circuit

Symbol	Pin No	Equivalence Circuit
EN1(/EN1) EN2(/EN2)	3, 4	
/OC1 /OC2	5, 8	
OUT1 OUT2	6, 7	

## Operational Notes

### 1. Reverse Connection of Power Supply

Connecting the power supply in reverse polarity can damage the IC. Take precautions against reverse polarity when connecting the power supply, such as mounting an external diode between the power supply and the IC's power supply pins.

### 2. Power Supply Lines

Design the PCB layout pattern to provide low impedance supply lines. Furthermore, connect a capacitor to ground at all power supply pins. Consider the effect of temperature and aging on the capacitance value when using electrolytic capacitors.

### 3. Ground Voltage

Ensure that no pins are at a voltage below that of the ground pin at any time, even during transient condition.

### 4. Ground Wiring Pattern

When using both small-signal and large-current ground traces, the two ground traces should be routed separately but connected to a single ground at the reference point of the application board to avoid fluctuations in the small-signal ground caused by large currents. Also ensure that the ground traces of external components do not cause variations on the ground voltage. The ground lines must be as short and thick as possible to reduce line impedance.

### 5. Thermal Consideration

Should by any chance the power dissipation rating be exceeded the rise in temperature of the chip may result in deterioration of the properties of the chip. In case of exceeding this absolute maximum rating, increase the board size and copper area to prevent exceeding the Pd rating.

### 6. Recommended Operating Conditions

These conditions represent a range within which the expected characteristics of the IC can be approximately obtained. The electrical characteristics are guaranteed under the conditions of each parameter.

### 7. Inrush Current

When power is first supplied to the IC, it is possible that the internal logic may be unstable and inrush current may flow instantaneously due to the internal powering sequence and delays, especially if the IC has more than one power supply. Therefore, give special consideration to power coupling capacitance, power wiring, width of ground wiring, and routing of connections.

### 8. Operation Under Strong Electromagnetic Field

Operating the IC in the presence of a strong electromagnetic field may cause the IC to malfunction.

### 9. Testing on Application Boards

When testing the IC on an application board, connecting a capacitor directly to a low-impedance output pin may subject the IC to stress. Always discharge capacitors completely after each process or step. The IC's power supply should always be turned off completely before connecting or removing it from the test setup during the inspection process. To prevent damage from static discharge, ground the IC during assembly and use similar precautions during transport and storage.

### 10. Inter-pin Short and Mounting Errors

Ensure that the direction and position are correct when mounting the IC on the PCB. Incorrect mounting may result in damaging the IC. Avoid nearby pins being shorted to each other especially to ground, power supply and output pin. Inter-pin shorts could be due to many reasons such as metal particles, water droplets (in very humid environment) and unintentional solder bridge deposited in between pins during assembly to name a few.

### 11. Unused Input Pins

Input pins of an IC are often connected to the gate of a MOS transistor. The gate has extremely high impedance and extremely low capacitance. If left unconnected, the electric field from the outside can easily charge it. The small charge acquired in this way is enough to produce a significant effect on the conduction through the transistor and cause unexpected operation of the IC. So unless otherwise specified, unused input pins should be connected to the power supply or ground line.

## Operational Notes – continued

**12. Regarding the Input Pin of the IC**

This monolithic IC contains P+ isolation and P substrate layers between adjacent elements in order to keep them isolated. P-N junctions are formed at the intersection of the P layers with the N layers of other elements, creating a parasitic diode or transistor. For example (refer to figure below):

When  $GND > Pin A$  and  $GND > Pin B$ , the P-N junction operates as a parasitic diode.

When  $GND > Pin B$ , the P-N junction operates as a parasitic transistor.

Parasitic diodes inevitably occur in the structure of the IC. The operation of parasitic diodes can result in mutual interference among circuits, operational faults, or physical damage. Therefore, conditions that cause these diodes to operate, such as applying a voltage lower than the GND voltage to an input pin (and thus to the P substrate) should be avoided.

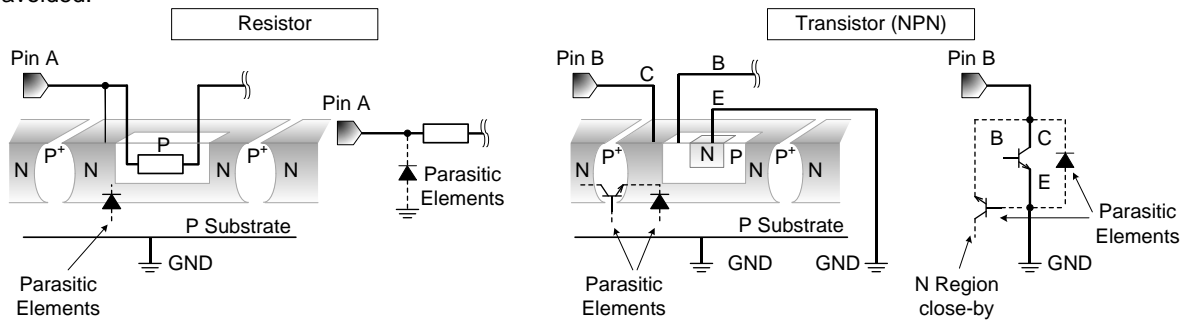

Figure 41. Example of monolithic IC structure

**13. Ceramic Capacitor**

When using a ceramic capacitor, determine the dielectric constant considering the change of capacitance with temperature and the decrease in nominal capacitance due to DC bias and others.

**14. Area of Safe Operation (ASO)**

Operate the IC such that the output voltage, output current, and power dissipation are all within the Area of Safe Operation (ASO).

**15. Thermal Shutdown Circuit(TSD)**

This IC has a built-in thermal shutdown circuit that prevents heat damage to the IC. Normal operation should always be within the IC's power dissipation rating. If however the rating is exceeded for a continued period, the junction temperature ( $T_j$ ) will rise which will activate the TSD circuit that will turn OFF all output pins. When the  $T_j$  falls below the TSD threshold, the circuits are automatically restored to normal operation.

Note that the TSD circuit operates in a situation that exceeds the absolute maximum ratings and therefore, under no circumstances, should the TSD circuit be used in a set design or for any purpose other than protecting the IC from heat damage.

**16. Over Current Protection Circuit (OCP)**

This IC incorporates an integrated overcurrent protection circuit that is activated when the load is shorted. This protection circuit is effective in preventing damage due to sudden and unexpected incidents. However, the IC should not be used in applications characterized by continuous operation or transitioning of the protection circuit.

Ordering Information

B D 2 0 6 8 F J

M G E 2

Part Number

Package  
FJ: SOP-J8

Product Rank  
M: for Automotive  
Packaging and forming specification  
G: Halogen free  
E2: Embossed tape and reel

B D 2 0 6 9 F J

M G E 2

Part Number

Package  
FJ: SOP-J8

Product Rank  
M: for Automotive  
Packaging and forming specification  
G: Halogen free  
E2: Embossed tape and reel

Marking Diagram

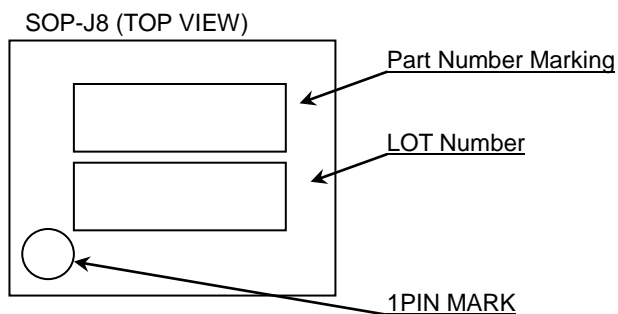

Part Number	Part Number Marking
BD2068FJ-M	D2068
BD2069FJ-M	D2069

Physical Dimension, Tape and Reel Information

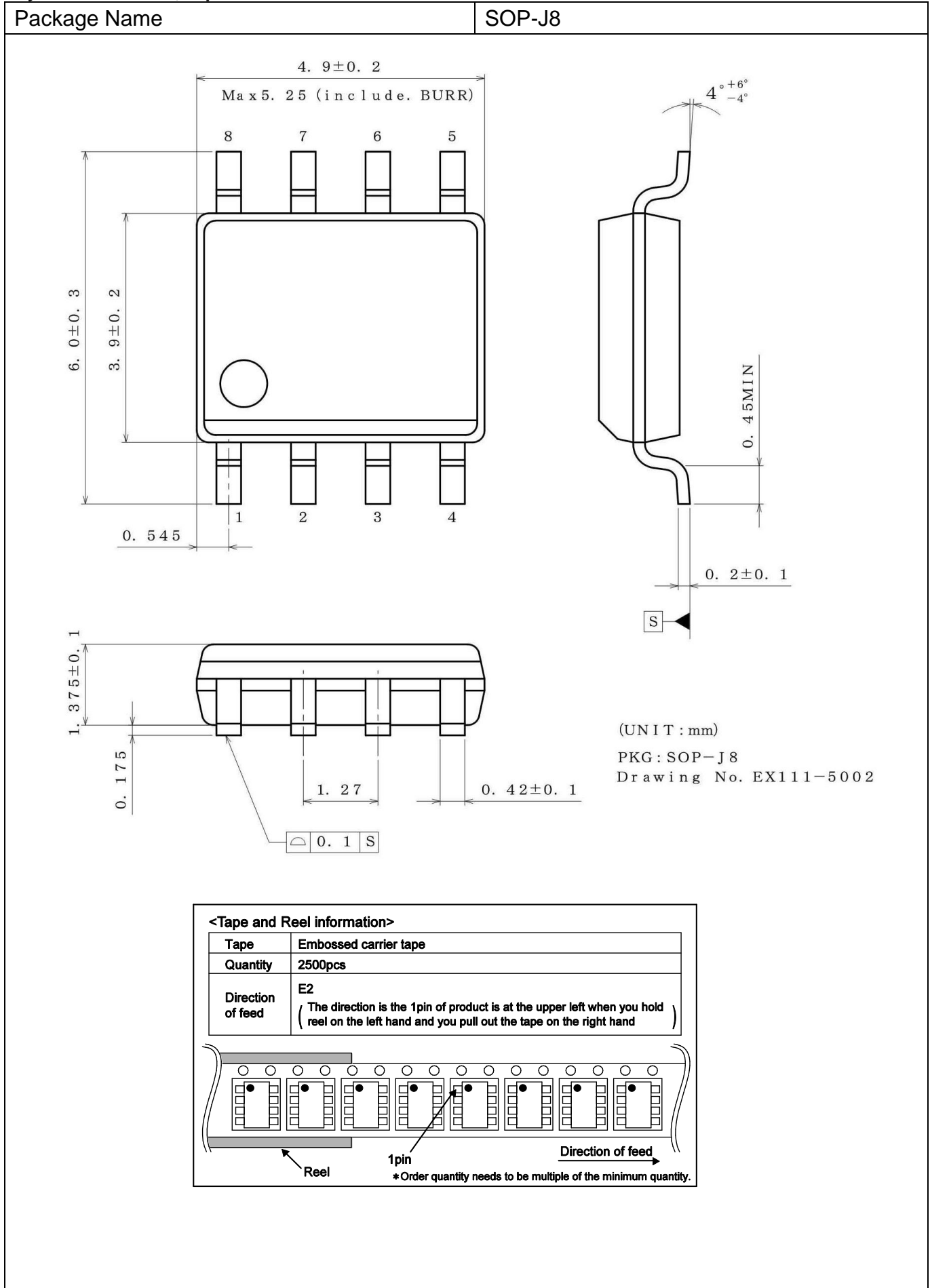

Revision History

Date	Revision	Changes
7.Apr.2015	001	New Release

# Notice

## Precaution on using ROHM Products

1. If you intend to use our Products in devices requiring extremely high reliability (such as medical equipment <sup>(Note 1)</sup>, aircraft/spacecraft, nuclear power controllers, etc.) and whose malfunction or failure may cause loss of human life, bodily injury or serious damage to property ("Specific Applications"), please consult with the ROHM sales representative in advance. Unless otherwise agreed in writing by ROHM in advance, ROHM shall not be in any way responsible or liable for any damages, expenses or losses incurred by you or third parties arising from the use of any ROHM's Products for Specific Applications.

(Note1) Medical Equipment Classification of the Specific Applications

JAPAN	USA	EU	CHINA
CLASS III	CLASS III	CLASS II b	CLASS III
CLASS IV		CLASS III	

2. ROHM designs and manufactures its Products subject to strict quality control system. However, semiconductor products can fail or malfunction at a certain rate. Please be sure to implement, at your own responsibilities, adequate safety measures including but not limited to fail-safe design against the physical injury, damage to any property, which a failure or malfunction of our Products may cause. The following are examples of safety measures:
  - [a] Installation of protection circuits or other protective devices to improve system safety
  - [b] Installation of redundant circuits to reduce the impact of single or multiple circuit failure
3. Our Products are not designed under any special or extraordinary environments or conditions, as exemplified below. Accordingly, ROHM shall not be in any way responsible or liable for any damages, expenses or losses arising from the use of any ROHM's Products under any special or extraordinary environments or conditions. If you intend to use our Products under any special or extraordinary environments or conditions (as exemplified below), your independent verification and confirmation of product performance, reliability, etc, prior to use, must be necessary:
  - [a] Use of our Products in any types of liquid, including water, oils, chemicals, and organic solvents
  - [b] Use of our Products outdoors or in places where the Products are exposed to direct sunlight or dust
  - [c] Use of our Products in places where the Products are exposed to sea wind or corrosive gases, including Cl<sub>2</sub>, H<sub>2</sub>S, NH<sub>3</sub>, SO<sub>2</sub>, and NO<sub>2</sub>
  - [d] Use of our Products in places where the Products are exposed to static electricity or electromagnetic waves
  - [e] Use of our Products in proximity to heat-producing components, plastic cords, or other flammable items
  - [f] Sealing or coating our Products with resin or other coating materials
  - [g] Use of our Products without cleaning residue of flux (even if you use no-clean type fluxes, cleaning residue of flux is recommended); or Washing our Products by using water or water-soluble cleaning agents for cleaning residue after soldering
  - [h] Use of the Products in places subject to dew condensation
4. The Products are not subject to radiation-proof design.
5. Please verify and confirm characteristics of the final or mounted products in using the Products.
6. In particular, if a transient load (a large amount of load applied in a short period of time, such as pulse. is applied, confirmation of performance characteristics after on-board mounting is strongly recommended. Avoid applying power exceeding normal rated power; exceeding the power rating under steady-state loading condition may negatively affect product performance and reliability.
7. De-rate Power Dissipation (Pd) depending on Ambient temperature (Ta). When used in sealed area, confirm the actual ambient temperature.
8. Confirm that operation temperature is within the specified range described in the product specification.
9. ROHM shall not be in any way responsible or liable for failure induced under deviant condition from what is defined in this document.

## Precaution for Mounting / Circuit board design

1. When a highly active halogenous (chlorine, bromine, etc.) flux is used, the residue of flux may negatively affect product performance and reliability.
2. In principle, the reflow soldering method must be used on a surface-mount products, the flow soldering method must be used on a through hole mount products. If the flow soldering method is preferred on a surface-mount products, please consult with the ROHM representative in advance.

For details, please refer to ROHM Mounting specification

### Precautions Regarding Application Examples and External Circuits

1. If change is made to the constant of an external circuit, please allow a sufficient margin considering variations of the characteristics of the Products and external components, including transient characteristics, as well as static characteristics.
2. You agree that application notes, reference designs, and associated data and information contained in this document are presented only as guidance for Products use. Therefore, in case you use such information, you are solely responsible for it and you must exercise your own independent verification and judgment in the use of such information contained in this document. ROHM shall not be in any way responsible or liable for any damages, expenses or losses incurred by you or third parties arising from the use of such information.

### Precaution for Electrostatic

This Product is electrostatic sensitive product, which may be damaged due to electrostatic discharge. Please take proper caution in your manufacturing process and storage so that voltage exceeding the Products maximum rating will not be applied to Products. Please take special care under dry condition (e.g. Grounding of human body / equipment / solder iron, isolation from charged objects, setting of Ionizer, friction prevention and temperature / humidity control).

### Precaution for Storage / Transportation

1. Product performance and soldered connections may deteriorate if the Products are stored in the places where:
  - [a] the Products are exposed to sea winds or corrosive gases, including Cl<sub>2</sub>, H<sub>2</sub>S, NH<sub>3</sub>, SO<sub>2</sub>, and NO<sub>2</sub>
  - [b] the temperature or humidity exceeds those recommended by ROHM
  - [c] the Products are exposed to direct sunshine or condensation
  - [d] the Products are exposed to high Electrostatic
2. Even under ROHM recommended storage condition, solderability of products out of recommended storage time period may be degraded. It is strongly recommended to confirm solderability before using Products of which storage time is exceeding the recommended storage time period.
3. Store / transport cartons in the correct direction, which is indicated on a carton with a symbol. Otherwise bent leads may occur due to excessive stress applied when dropping of a carton.
4. Use Products within the specified time after opening a humidity barrier bag. Baking is required before using Products of which storage time is exceeding the recommended storage time period.

### Precaution for Product Label

QR code printed on ROHM Products label is for ROHM's internal use only.

### Precaution for Disposition

When disposing Products please dispose them properly using an authorized industry waste company.

### Precaution for Foreign Exchange and Foreign Trade act

Since concerned goods might be fallen under listed items of export control prescribed by Foreign exchange and Foreign trade act, please consult with ROHM in case of export.

### Precaution Regarding Intellectual Property Rights

1. All information and data including but not limited to application example contained in this document is for reference only. ROHM does not warrant that foregoing information or data will not infringe any intellectual property rights or any other rights of any third party regarding such information or data.
2. ROHM shall not have any obligations where the claims, actions or demands arising from the combination of the Products with other articles such as components, circuits, systems or external equipment (including software).
3. No license, expressly or implied, is granted hereby under any intellectual property rights or other rights of ROHM or any third parties with respect to the Products or the information contained in this document. Provided, however, that ROHM will not assert its intellectual property rights or other rights against you or your customers to the extent necessary to manufacture or sell products containing the Products, subject to the terms and conditions herein.

### Other Precaution

1. This document may not be reprinted or reproduced, in whole or in part, without prior written consent of ROHM.
2. The Products may not be disassembled, converted, modified, reproduced or otherwise changed without prior written consent of ROHM.
3. In no event shall you use in any way whatsoever the Products and the related technical information contained in the Products or this document for any military purposes, including but not limited to, the development of mass-destruction weapons.
4. The proper names of companies or products described in this document are trademarks or registered trademarks of ROHM, its affiliated companies or third parties.



**General Precaution**

1. Before you use our Products, you are requested to carefully read this document and fully understand its contents. ROHM shall not be in any way responsible or liable for failure, malfunction or accident arising from the use of any ROHM's Products against warning, caution or note contained in this document.
2. All information contained in this document is current as of the issuing date and subject to change without any prior notice. Before purchasing or using ROHM's Products, please confirm the latest information with a ROHM sales representative.
3. The information contained in this document is provided on an "as is" basis and ROHM does not warrant that all information contained in this document is accurate and/or error-free. ROHM shall not be in any way responsible or liable for any damages, expenses or losses incurred by you or third parties resulting from inaccuracy or errors of or concerning such information.