



BD245 – A – B – C

NPN SINGLE-DIFFUSED MESA SILICON POWER TRANSISTORS

They are the power transistors for power amplifier and high-speed-switching applications. The complementary is BD246, A, B, C
Compliance to RoHS.

ABSOLUTE MAXIMUM RATINGS

Symbol	Ratings	Value	Unit	
V _{CEO}	Collector-Emitter Voltage (I _C = -30mA)	BD245	45	V
		BD245A	60	
		BD245B	80	
		BD245C	100	
V _{CER}	Collector-Emitter Voltage (R _{BE} = 100 Ω)	BD245	55	V
		BD245A	70	
		BD245B	90	
		BD245C	115	
V _{EBO}	Emitter-Base Voltage	5.0	V	
I _C	Collector Current	I _C	10	A
		I _{CM}	15	
I _B	Base Current	3	A	
P _T	Power Dissipation T _{mb} = 25° C	80	Watts	
T _J	Junction Temperature	-65 to +150	°C	
T _S	Storage Temperature	-65 to +150		

THERMAL CHARACTERISTICS

Symbol	Ratings	Value	Unit
R _{thJC}	Junction to Case Thermal Resistance	1.56	°C / W
R _{thJA}	Junction to free air Thermal Resistance	42	°C / W

BD245 – A – B – C

ELECTRICAL CHARACTERISTICS

TC=25°C unless otherwise noted

Symbol	Ratings	Test Condition(s)	Min	Typ	Max	Unit	
I_{CES}	Collector- Emitter Cut-off Current	$V_{CE} = 55 \text{ V}, V_{BE} = 0$	BD245	-	-	0.4	mA
		$V_{CE} = 70 \text{ V}, V_{BE} = 0$	BD245A				
		$V_{CE} = 90 \text{ V}, V_{BE} = 0$	BD245B				
		$V_{CE} = 115 \text{ V}, V_{BE} = 0$	BD245C				
I_{CEO}	Collector Cut-off Current	$V_{CE} = 30 \text{ V}, I_B = 0$	BD245	-	-	0.7	mA
			BD245A				
		$V_{CE} = 60 \text{ V}, I_B = 0$	BD245B				
			BD245C				
I_{EBO}	Emitter Cut-off Current	$V_{EB} = 5 \text{ V}, I_C = 0$	-	-	1	mA	
V_{CEO}	Collector- Emitter Breakdown Voltage (*)	$I_C = 30 \text{ mA}, I_B = 0$	BD245	45	-	-	V
			BD245A	60	-	-	
			BD245B	80	-	-	
			BD245C	100	-	-	
h_{FE}	DC Current Gain (*)	$V_{CE} = 4 \text{ V}, I_C = 1 \text{ A}$	40	-	-	-	
		$V_{CE} = 4 \text{ V}, I_C = 3 \text{ A}$	20	-	-		
		$V_{CE} = 4 \text{ V}, I_C = 10 \text{ A}$	4	-	-		
$V_{CE(SAT)}$	Collector-Emitter saturation Voltage (*)	$I_C = 3 \text{ A}, I_B = 300 \text{ mA}$	-	-	1	V	
		$I_C = 10 \text{ A}, I_B = 2.5 \text{ A}$	-	-	4		
V_{BE}	Base-Emitter Voltage(*)	$V_{CE} = 4 \text{ V}, I_C = 3 \text{ A}$	-	-	1.6	V	
		$V_{CE} = 4 \text{ V}, I_C = 10 \text{ A}$	-	-	3		
h_{fe}	Small Signal forward Current Transfer ratio	$V_{CE} = 10 \text{ V}, I_C = 500 \text{ mA}$ $f = 1 \text{ MHz}$	20	-	-	-	
$ h_{fe} $	Small Signal forward Current Transfer ratio	$V_{CE} = 10 \text{ V}, I_C = 500 \text{ m}$ $Af = 1 \text{ MHz}$	3	-	-	-	

(*) Pulse Width $\approx 300 \mu\text{s}$, Duty Cycle $\leq 2.0\%$

RESISTIVE-LOAD-SWITCHING CHARACTERISTICS AT 25°C CASE TEMPERATURE

Symbol	Ratings	Test Condition(s)	Min	Typ	Max	Unit
t_{on}	Turn-on Time	$I_C = 1 \text{ A}, I_{B(on)} = 100 \text{ mA},$ $I_{B(off)} = -100 \text{ mA}$ $V_{BE(off)} = -3.7 \text{ V}, R_L = 20 \Omega$	-	0.3	-	μs
t_{off}	Turn-off Time		$t_p = 20 \mu\text{s}$ $dc < 2\%$	-	1	

BD245 – A – B – C

MECHANICAL DATA CASE TO3PN Non Isolated Plastic Package

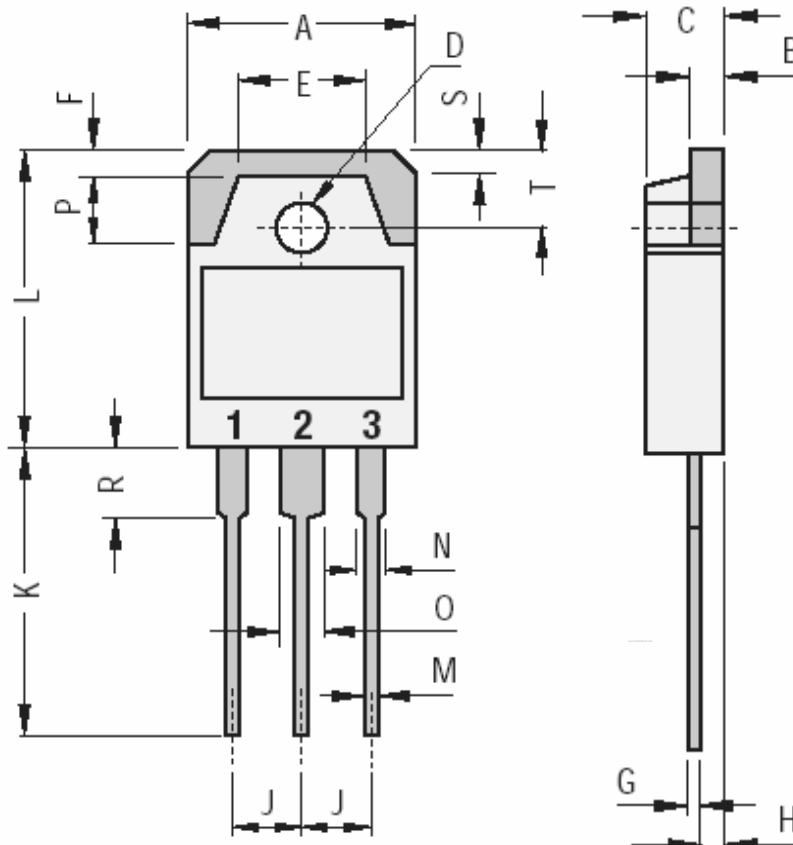

DIMENSIONS (mm)		
	Min.	Max.
A	15.20	1600
B	1.90	2.10
C	4.60	5.00
D	3.10	3.30
E		9.60
F		2.00
G	0.35	0.55
H		1.40
J	5.35	5.55
K	20.00	
L	19.60	20.20
M	0.95	1.25
N		2.00
O		3.00
P		4.00
R		4.00
S		1.80
T	4.80	5.20

Pin 1 :	Base
Pin 2 :	Collector
Pin 3 :	Emitter

Revised August 2012

Information furnished is believed to be accurate and reliable. However, Comset Semiconductors assumes no responsibility for the consequences of use of such information nor for any infringement of patents or other rights of third parties which may result from its use. Data are subject to change without notice. Comset Semiconductors makes no warranty, representation or guarantee regarding the suitability of its products for any particular purpose, nor does Comset Semiconductors assume any liability arising out of the application or use of any product and specifically disclaims any and all liability, including without limitation consequential or incidental damages. Comset Semiconductors' products are not authorized for use as critical components in life support devices or systems.