

36V 2ch DC Brush Motor Driver

BD60203EFV

General Description

BD60203EFV is 2ch H-bridge motor driver for DC brush motor. This driver can facilitate low power consumption by PWM constant current control. Various protection circuits are built in. And also a circuit for lock detection is built in, so it is possible to output an error detection signal corresponding to Wired-Or signaling motor lock status. It contributes to high reliability of the set.

Features

- Single Power Supply Input (rated voltage of 36 V)
- Rated Output Current (peak): 1.7 A(3.0 A)
- Low ON-Resistance DMOS Output
- PH, EN Input
- Power Save Function
- PWM Constant Current Control (current limit function)
- Built-in Spike Noise Cancel Function (external noise filter is unnecessary)
- Driver for 2 DC Brush Motor
- Built-in Logic Input Pull-down Resistor
- Cross-conduction Prevention Circuit
- Thermal Shutdown Circuit (TSD)
- Over-current Protection Circuit (OCP)
- Under Voltage Lockout Circuit (UVLO)
- Over Voltage Lockout Circuit (OVLO)
- Built-in Comparator for Lock Detection
- Ghost Supply Prevention (protects against malfunction when power supply is disconnected)
- Microminiature, Ultra-thin and High Heat-radiation (exposed metal type) HTSSOP-B24 Package

Applications

Plain Paper Copier (PPC), Multi-function Printer, Laser Printer, Inkjet Printer, Photo Printer, FAX, Mini Printer and etc.

Key Specifications

- Power Supply Voltage Range: 8.0 V to 28.0 V
- Rated Output Current: 1.7 A
- Rated Output Current (Peak): 3.0 A
- Operating Temperature Range: -25 °C to +85 °C
- Output ON-Resistance: 0.65 Ω (Typ)
(Total of upper and lower resistors)

Package

HTSSOP-B24

W(Typ) x D(Typ)x H(Max)
7.80 mm x 7.60 mm x 1.00 mm

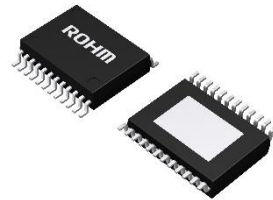

Figure 1. HTSSOP-B24

Typical Application Circuit

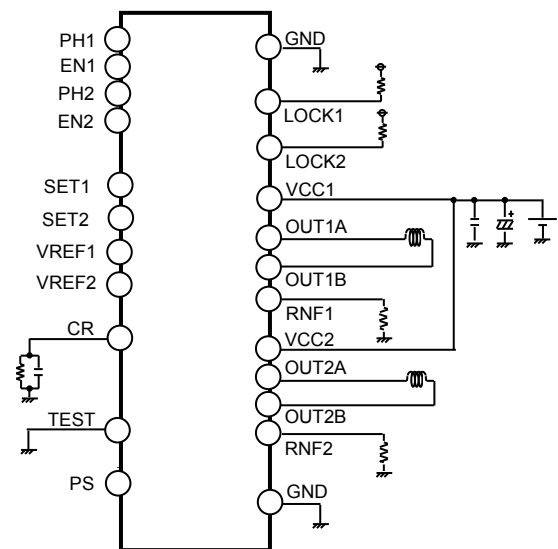

Figure 2. Application Circuit

Pin Configuration

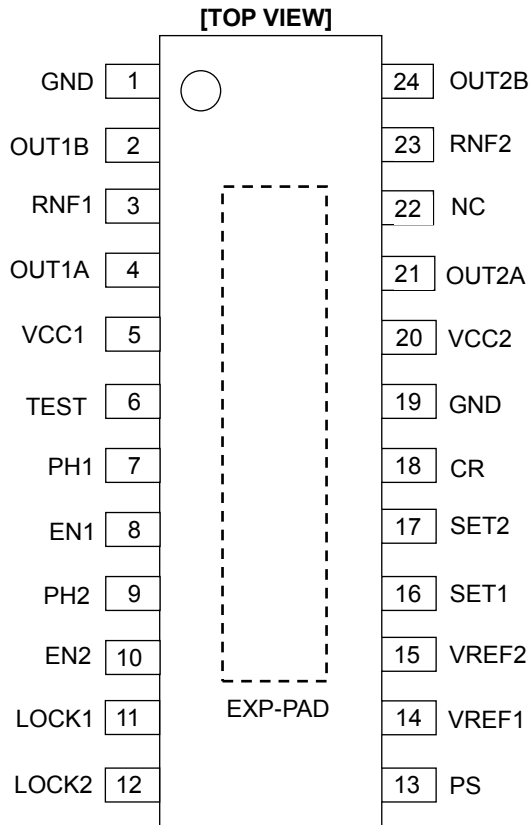

Figure 3. Pin Configuration

Block Diagram

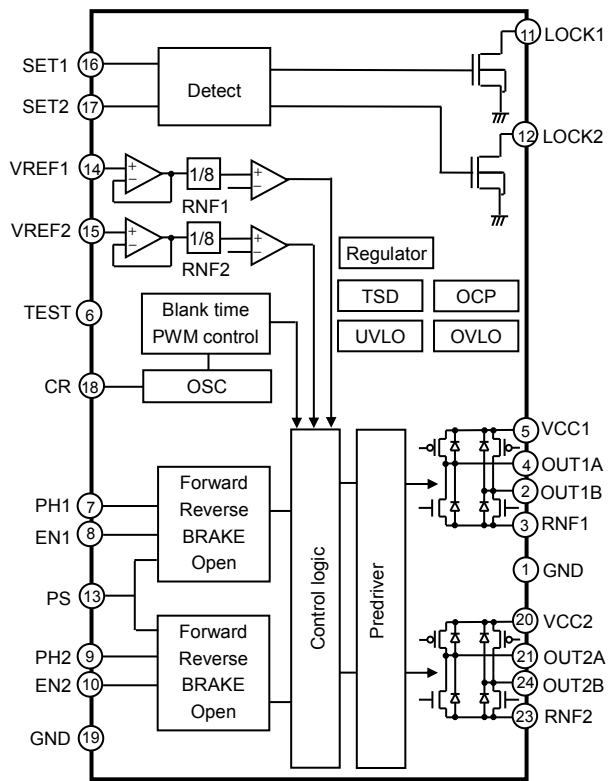

Figure 4. Block Diagram

Pin Descriptions

Pin No.	Pin Name	Function	Pin No.	Pin Name	Function
1	GND	Ground pin	13	PS	Power save pin
2	OUT1B	H bridge output pin	14	VREF1	Current limit value setting pin
3	RNF1	Connection pin of resistor for output current detection	15	VREF2	Current limit value setting pin
4	OUT1A	H bridge output pin	16	SET1	Motor lock current setting pin
5	VCC1	Power supply pin	17	SET2	Motor lock current setting pin
6	TEST	Test pin (Connected to GND)	18	CR	Chopping frequency setting pin
7	PH1	H bridge control pin	19	GND	Ground pin
8	EN1	H bridge control pin	20	VCC2	Power supply pin
9	PH2	H bridge control pin	21	OUT2A	H bridge output pin
10	EN2	H bridge control pin	22	NC	No connection
11	LOCK1	Motor lock detection signal output pin	23	RNF2	Connection pin of resistor for output current detection
12	LOCK2	Motor lock detection signal output pin	24	OUT2B	H bridge output pin
-	EXP-PAD	The EXP-PAD of the center of product connected to GND.	-	-	-

Absolute Maximum Ratings (Ta=25 °C)

Parameter	Symbol	Rating	Unit
Supply Voltage	VCC1, VCC2	-0.2 to +36.0	V
Input Voltage for Control Pin	V _{IN}	-0.3 to +5.5	V
RNF Maximum Voltage	V _{RNF}	0.7	V
Output Current	I _{OUT}	1.7 ^(Note 1)	A/ch
Output Current (Peak) ^(Note 2)	I _{OUTPEAK}	3.0 ^(Note 1)	A/ch
Storage Temperature Range	T _{stg}	-55 to +150	°C
Maximum Junction Temperature	T _{jmax}	+150	°C

Caution 1: Operating the IC over the absolute maximum ratings may damage the IC. The damage can either be a short circuit between pins or an open circuit between pins and the internal circuitry. Therefore, it is important to consider circuit protection measures, such as adding a fuse, in case the IC is operated over the absolute maximum ratings.

Caution 2: Should by any chance the maximum junction temperature rating be exceeded the rise in temperature of the chip may result in deterioration of the properties of the chip. In case of exceeding this absolute maximum rating, design a PCB with thermal resistance taken into consideration by increasing board size and copper area so as not to exceed the maximum junction temperature rating.

(Note 1) Do not exceed T_{jmax}=150 °C.

(Note 2) Pulse width tw ≤1ms, duty 20 %

Thermal Resistance^(Note 3)

Parameter	Symbol	Thermal Resistance (Typ)		Unit
		1s ^(Note 5)	2s2p ^(Note 6)	
HTSSOP-B24				
Junction to Ambient	θ _{JA}	143.8	26.4	°C/W
Junction to Top Characterization Parameter ^(Note 4)	Ψ _{JT}	7	2	°C/W

(Note 3) Based on JESD51-2A(Still-Air).

(Note 4) The thermal characterization parameter to report the difference between junction temperature and the temperature at the top center of the outside surface of the component package.

(Note 5) Using a PCB board based on JESD51-3.

(Note 6) Using a PCB board based on JESD51-5, 7.

Layer Number of Measurement Board	Material	Board Size
Single	FR-4	114.3 mm x 76.2 mm x 1.57 mmt

Top	
Copper Pattern	Thickness
Footprints and Traces	70 μm

Layer Number of Measurement Board	Material	Board Size	Thermal Via ^(Note 7)	
			Pitch	Diameter
4 Layers	FR-4	114.3 mm x 76.2 mm x 1.6 mmt	1.20 mm	Φ0.30 mm

Top		2 Internal Layers		Bottom	
Copper Pattern	Thickness	Copper Pattern	Thickness	Copper Pattern	Thickness
Footprints and Traces	70 μm	74.2 mm x 74.2 mm	35 μm	74.2 mm x 74.2 mm	70 μm

(Note 7) This thermal via connects with the copper pattern of all layers.

Recommended Operating Conditions

Parameter	Symbol	Min	Typ	Max	Unit
Operating Temperature	Topr	-25	+25	+85	°C
Supply Voltage	VCC1, VCC2	+8	+24	+28	V
Maximum Output Current (Continuous)	I _{OUT}	-	-	+1.2 ^(Note 8)	A/ch

(Note 8) Do not exceed T_{jmax}=150 °C.

Electrical Characteristics (Unless otherwise specified Ta=25 °C, VCC1, VCC2=24 V)

Parameter	Symbol	Limit			Unit	Conditions
		Min	Typ	Max		
[Whole]						
Circuit Current at Standby	I _{CCST}	-	-	10	μA	PS=L
Circuit Current	I _{CC}	-	2.5	5.0	mA	PS=H, VREFx ^(Note 9) =2 V
[Control Input]						
H Level Input Voltage	V _{INH}	2.0	-	-	V	
L Level Input Voltage	V _{INL}	-	-	0.8	V	
H Level Input Current	I _{INH}	35	50	100	μA	V _{IN} =5 V
L Level Input Current	I _{INL}	-10	0	-	μA	V _{IN} =0 V
[Output (OUT1A, OUT1B, OUT2A, OUT2B)]						
Output ON-Resistance	R _{ON}	-	0.65	0.85	Ω	I _{OUT} =±1.0 A (Sum of upper and lower)
Output Leak Current	I _{LEAK}	-	-	10	μA	
[Current Control]						
RNFx ^(Note 10) Input Current	I _{RNF}	-80	-40	-	μA	RNFx=0 V
VREFx Input Current	I _{VREF}	-2.0	-0.1	-	μA	VREFx=0 V
VREFx Input Voltage Range	V _{VREF}	-	-	2.0	V	
Minimum ON Time (Blank Time)	t _{ONMIN}	1.5	3.0	5.5	μs	
Comparator Threshold Accuracy	V _{CTH1}	-0.02	0	+0.02	V	VREFx=1.5 V
[Lock]						
SETx ^(Note 11) Input Current	I _{SET}	-2.0	0	-	μA	SETx=0 V
SETx Input Voltage Range	V _{SET}	0	-	2.0	V	
Comparator Threshold Accuracy	V _{CTH2}	-0.03	0	+0.03	V	SETx=2 V

(Note 9) x=1 or 2

(Note 10) x=1 or 2

(Note 11) x=1 or 2

Application Information and Points to Notice for Pin Description and PCB Layout

PS/ Power Save Pin

PS can make circuit into standby state and make motor outputs OPEN.

Be careful because there is a delay of 40 μs (Max) at PS=L→H, until it is returned from standby state to normal state and the motor output becomes ACTIVE.

PS	State
L	POWER SAVE (STANDBY)
H	ACTIVE

IN1, IN2/ H Bridge Control Pin

It decides output logic for H bridge.

Input			Output		State
PS	EN1 EN2	PH1 PH2	OUT1A OUT2A	OUT1B OUT2B	
L	x ^(Note 12)	x ^(Note 12)	OPEN	OPEN	POWER SAVE (STANDBY)
H	L	L	L	L	STOP
H	H	L	L	H	REVERSE
H	L	H	OPEN	OPEN	BRAKE
H	H	H	H	L	FORWARD

(Note 12) x=H or L

VCC1, VCC2/ Power Supply Pin

Motor's drive current is flowing in it, so the wire should be thick, short and has low impedance. Voltage VCC may have great fluctuation, so arrange the bypass capacitor of about 100 μF to 470 μF as close to the pin as possible and adjust the voltage VCC is stable. When 100 μF or less is selected, please confirm that the voltage of the VCC1 and VCC2 pins of the IC does not exceed the rating even instantly. Also, please make sure that there is no breakdown / malfunction etc. even if the VCC1 and VCC2 pins voltage is within the rating. In particular, when using a large current or a motor with a large counter electromotive force, please add the capacity of the capacitor as necessary. In addition, for the purpose of reducing of power supply's impedance in wideband, it is recommended to set parallel connection of multi-layered ceramic capacitor of 0.01 μF to 0.1 μF etc. Extreme care must be used to make sure that the voltage VCC does not exceed the rating even for a moment. The VCC1 pin and the VCC2 pin are shorted inside the IC, but be sure to short externally the VCC1 and the VCC2 pins when using. If used without shorting, malfunction or destruction may occur because of concentration of current routes etc. Still more, in the power supply pin, there is built-in clamp component for preventing of electrostatic destruction. When a steep pulse signal or voltage such as a surge exceeding the absolute maximum rating is applied, this clamp component operates, as a result there is the danger of destruction, so be sure that the absolute maximum rating must not be exceeded. It is effective to mount a Zener diode of about the absolute maximum rating. Moreover, the diode for preventing of electrostatic destruction is inserted between the VCC1, the VCC2 and the GND pins, as a result there is the danger of IC destruction if reverse voltage is applied between the VCC1, the VCC2 and the GND pins, so be careful.

GND/ Ground Pin

In order to reduce the noise caused by switching current and to stabilize the internal reference voltage of IC, the wiring impedance from this pin is made as low as possible to achieve the lowest electrical potential no matter what operating state it may be. Moreover, design patterns not to have any common impedance with other GND patterns.

OUT1A, OUT1B, OUT2A, OUT2B / H Bridge Output Pin

Motor's drive current is flowing in it, so the wire should be thick, short and has low impedance. It is also effective to add a Schottky diode if output has positive or negative great fluctuation when large current is used. For example, counter electromotive voltage etc. Moreover, in the output pin, there is built-in clamp component for preventing of electrostatic destruction. When a steep pulse signal or voltage such as a surge exceeding the absolute maximum rating is applied, this clamp component operates, as a result there is the danger of even destruction, so be sure that the absolute maximum rating must not exceeded.

RNFx^(Note 13)/ Connection Pin of Resistor for Detecting of Output Current

Connect the resistor for current detection between this pin and GND. Determine the resistor so that power consumption $W=I_{out}^2 \cdot R$ [W] of the current-detecting resistor should not have exceed the power dissipation of the resistor and the absolute maximum rating of the RNFx pin. Also, when using the motor lock detection comparator, consider the two values of the current limit setting value and the motor lock detection setting value, and decide the resistance value of the RNFx pin.

In addition, it should have a low impedance and should not have a common impedance with other GND patterns because motor's drive current flows in the pattern through the RNFx pin to current-detecting resistor to GND. Do not exceed the rating because there is the possibility of circuits' malfunction etc. if the RNFx pin voltage has exceeded the maximum rating (0.7 V). If the RNFx pin is open, then there is the possibility of such malfunction as output current does not flow either, so do not let it open.

(Note 13) x=1 or 2

Application Information and Points to Notice for Pin Description and PCB Layout – continued

VREFx^(Note 14)/ Output Current Limit Setting Pin

This is the pin to set the current limit value. It can be set by the VREFx pin voltage and current-detecting resistor (RNF resistor).

$$I_{OUT} = \frac{V_{VREF}}{8} / RNF \quad [A]$$

Where:

I_{OUT} is the output current.

V_{VREF} is the voltage of output current limit setting.

RNF is the current-detecting resistor.

Avoid using it with the VREFx pin open because if the VREFx pin is open, the input is unsettled, and there is the possibility of malfunctions such as the setting current increases and a large current flows. Keep to the input voltage range because if the voltage of 2 V or more is applied on the VREFx pin, there is also the danger that a large current flows in the output and OCP or TSD will operate. Besides, select the resistance value in consideration of the outflow current (Max 2 μA) if it is inputted by resistance division. If the setting voltages of the VREF1 and the VREF2 pins are equal, there is no problem even if the VREF1 and the VREF2 pins are short-circuited and input. The minimum current, which can be controlled by the VREFx pin voltage, is determined by motor coil's L, R values and minimum ON time because there is a minimum ON time in PWM drive.

(Note 14) x=1 or 2

CR/ Chopping Frequency Setting Pin

This is the pin to set the switching frequency of the output. Please connect the external C (330 pF to 680 pF) and R (10 kΩ to 150 kΩ) between this pin and GND. Please refer to [PWM Constant Current Control](#).

Please connect the external components to GND in such a way that the interconnection does not have impedance in common with other GND patterns. In addition, please create the pattern design in such a way to keep sudden pulses as square wave etc. away and that there is no noise spike. Please mount the two components of C and R if PWM constant current control is being used. This is because normal PWM constant current control cannot be used if the CR pin is open or it is biased externally. When not using PWM constant current control, connect this pin to GND.

SETx^(Note 15)/ Motor Lock Current Setting Pin

Compare the voltage set by the SETx pin with 4 times the voltage of the RNFx^(Note 16) pin, and when the RNFx pin voltage increases, the LOCKx^(Note 17) pin become L. For this output voltage, a mask circuit of about 50 μs (Typ) is provided for detection and release in order to prevent malfunction.

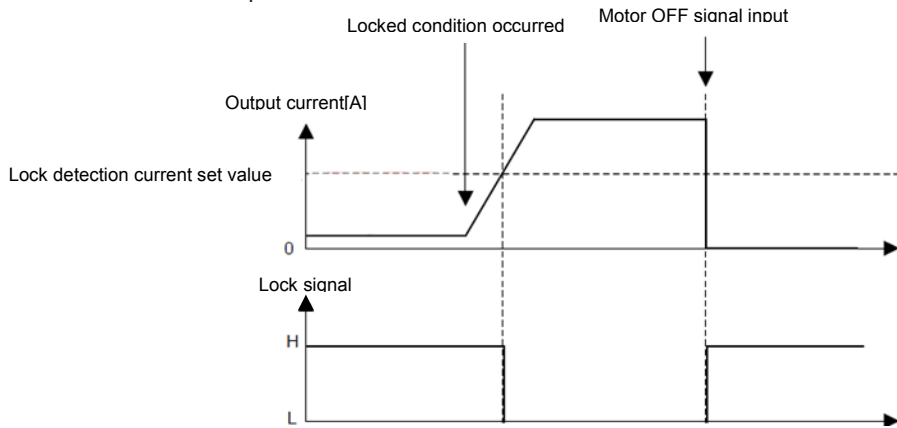

Figure 5. Lock Signal Timing Chart

LOCKx/ Motor Lock Detection Signal Output Pin

When the RNFx pin voltage becomes higher than the voltage set by the SETx pin, the LOCKx pin drop to L. This signal can be connected to the microcomputer and the system can be shut down. Since the output format of this pin is an open drain type, please pull up the resistor of 5 kΩ to 100 kΩ in resistance to a power supply of 7 V or less (eg 5 V or 3.3 V power supply) before using. When this pin is not used, please use it with GND connection.

LOCK	Output LOCK pin
Non motion	H (OFF)
Motion	L (ON)

(Note 15) x=1 or 2

(Note 16) x=1 or 2

(Note 17) x=1 or 2

Application Information and Points to Notice for Pin Description and PCB Layout – continuedTEST/ Pin for Testing

This is the pin used at the time of distribution test. Connect to GND. Be careful because there is a possibility of malfunction if it is not connected to GND.

NC Pin

This pin is unconnected electrically with the IC internal circuit.

EXP-PAD

HTSSOP-B24 package has the heat-radiating metal on its backside. It is the precondition that making the heat-radiating treatment when in use. Therefore, it must be connected by solder with the GND plane on the board and ensure the sufficient heat-radiation area by taking the GND pattern as wide as possible. Moreover, the backside metal is shorted with IC chip's backside and becomes the GND potential, so there is the danger of malfunction and destruction if shorted with potentials other than GND. Never design any wiring patterns other than GND through the IC's backside.

Protection Circuits

Thermal Shutdown (TSD)

This IC has a built-in Thermal Shutdown circuit for thermal protection. When the IC's chip temperature rises 175 °C (Typ) or more, the motor output becomes OPEN. Also, when the temperature returns to 150 °C (Typ) or less, it automatically returns to normal operation. However, even when TSD is in operation, if heat is continued to be applied externally, heat overdrive can lead to destruction.

Over-Current Protection (OCP)

This IC has a built in Over-Current Protection circuit as a provision against destruction when the motor outputs are shorted to each other or VCC-motor output or motor output-GND is shorted. This circuit latches the motor output to OPEN condition when the regulated current flows for 4 μs (Typ). It returns with power reactivation or a reset of the PS pin. The over current protection circuit's only aim is to prevent the destruction of the IC from irregular situations such as motor output shorts, and is not meant to be used as protection or security for the set. Therefore, sets should not be designed to take into account this circuit's functions. After OCP operating, if irregular situations continue and the return by power reactivation or a reset of the PS pin is carried out repeatedly, then OCP operates repeatedly and the IC may generate heat or otherwise deteriorate. When the L value of the wiring is great due to the wiring being long of faults, ground faults and shorting, there is a possibility of destruction after the over current has flowed and the output pin voltage jumps up and the absolute maximum values can be exceeded. Also, when current which is the output current rating or more and the OCP detection current or less flows, the IC can heat up to over $T_{jmax}=150$ °C and can deteriorate, so current which exceeds the output rating should not be applied.

Under Voltage Lockout (UVLO)

This IC has a built-in Under Voltage Lockout function to prevent false operation such as IC output during power supply under voltage. When the applied voltage to the VCC pin goes 5 V (Typ) or less, the motor output is set to OPEN. This switching voltage has a 1 V (Typ) hysteresis to prevent malfunction due to noise etc. Be aware that this protection circuit does not operate during power save mode.

Over Voltage Lockout (OVLO)

This IC has a built-in Over Voltage Lockout function to protect the IC output and the motor during power supply over voltage. When the applied voltage to the VCC pin goes 32 V (Typ) or more, the motor output is set to OPEN. This switching voltage has a 1 V (Typ) hysteresis and a 4 μs (Typ) mask time to prevent malfunction due to noise etc. Although this over voltage locked out circuit is built-in, there is a possibility of destruction if the absolute maximum value for power supply voltage is exceeded. Therefore, the absolute maximum value should not be exceeded. Be aware that this protection circuit does not operate during power save mode.

Ghost Supply Prevention (protects against malfunction when power supply is disconnected)

If a control signal (PH1, PH2, EN1, EN2, PS, VREF1, VREF2, SET1, SET2) is applied when there is no power supplied to the IC, there is a function which prevents a malfunction where voltage is supplied to power supply of this IC or other IC in the set via the electrostatic destruction prevention diode from these input pins to the VCC. Therefore, there is no malfunction in the circuit even when voltage is supplied to these input pin while there is no power supply.

Operation Under Strong Electromagnetic Field

The IC is not designed for using in the presence of strong electromagnetic field. Be sure to confirm that no malfunction is found when using the IC in a strong electromagnetic field.

PWM Constant Current Control

This function can limit the peak current or switching current in driving DC brush motor.

(1) Current Control Operation

When the output transistor is turned on, the output current increases. When the RNF voltage (the voltage obtained by converting the output current by the external resistor of the RNF_x^(Note 18) pin) reaches the IC internal reference voltage value set by the VREF_x^(Note 19) input voltage, the current limit comparator operates and enters current decay mode. Thereafter the output turned on again after a period of time determined the internal timer. The process repeats itself constantly.

(Note 18) x=1 or 2

(Note 19) x=1 or 2

(2) Blank Time (Fixed in Internal Circuit)

In order to avoid misdetection of output current due to RNF spike noise that may occur when the output turns ON, the IC employs an automatic current detection-masking period (t_{ONMIN} 3.0 μs Typ). During this period, the current detection is disabled immediately after the output transistor is turned on. This allows for constant-current drive without the need for an external filter.

(3) CR Timer

The CR component connected to the CR pin is repeatedly charged and discharged between the V_{CRH} and V_{CRL} levels. The CR continues to discharge during this period until it reaches V_{CRL}, at which point the IC output is switched back ON. The CR charge time (t_{CHARGE}) and discharge time (t_{DISCHARGE}) are set by external components, according to the following formulas. The total of t_{CHARGE} and t_{DISCHARGE} the chopping period, t_{CHOP}.

$$t_{CHARGE} \approx C \times \frac{R' \times R}{R' + R} \times \ln \left(\frac{V_{CR} - 0.4}{V_{CR} - 1.0} \right) \quad [s]$$

t_{CHARGE} is CR charge time.

C is the capacitance of the CR pin.

R is the resistance of the CR pin.

R' is the CR pin internal impedance 5 kΩ(Typ)

V_{CR} is the CR pin voltage.

$$V_{CR} = V \times \frac{R}{R' + R} \quad [V]$$

V is the internal regulator voltage 5 V(Typ).

$$t_{DISCHARGE} \approx C \times R \times \ln \left(\frac{1 + \alpha}{0.4} \right) \quad [s]$$

t_{DISCHARGE} is the CR discharge time.

α is refer to the right graph.

$$t_{CHOP} = t_{CHARGE} + t_{DISCHARGE} \quad [s]$$

t_{CHOP} is the chopping period.

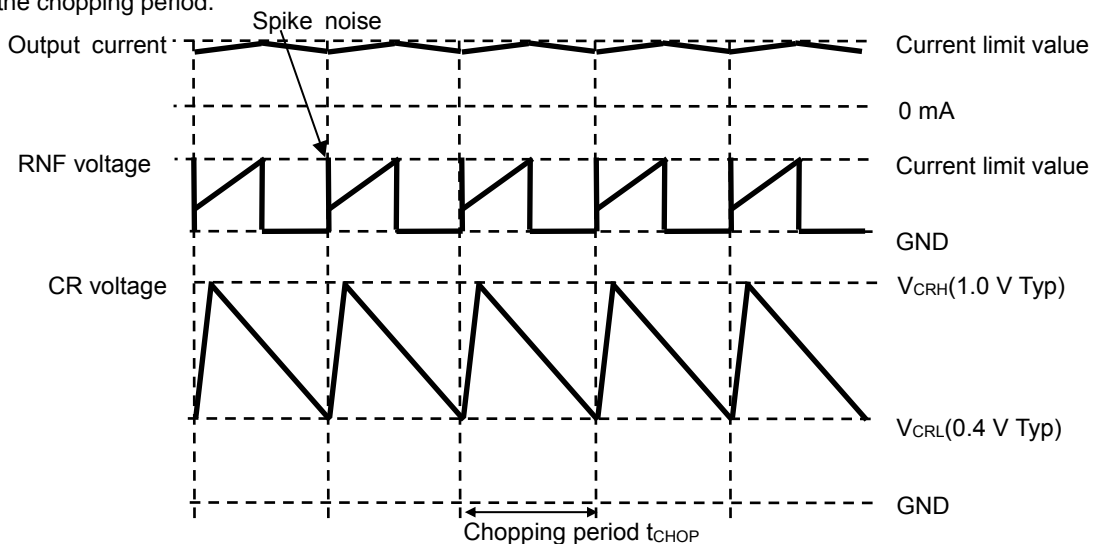
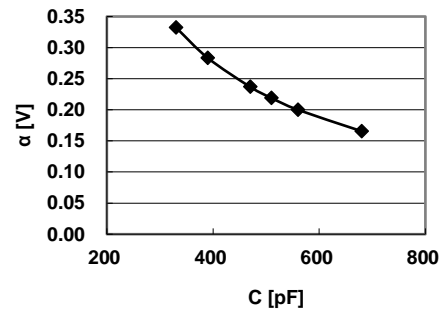

Figure 6. Timing Chart of Internal Voltage, RNF Voltage and Output Current

Power Dissipation

Confirm that the IC's chip temperature T_j is not over 150 °C in consideration of the IC's power consumption (W), thermal resistance (°C/W) and ambient temperature (T_a). When $T_j=150$ °C is exceeded, the functions as a semiconductor do not operate and problems such as parasitism and leaks occur. Constant use under these circumstances leads to deterioration and eventually destruction of the IC. $T_{jmax}=150$ °C must be strictly obeyed under all circumstances.

Thermal Calculation

The IC's consumed power can be estimated roughly with the power supply voltage (V_{CC}), circuit current (I_{CC}), output ON-Resistance (R_{ONH} , R_{ONL}) and motor output current value (I_{OUT}).

Here, the calculation method per H bridge 1ch in direct PWM drive (SLOW DECAY) is shown.

When using 2 channels at the same time, calculate for each H bridge.

$$W_{VCC} = V_{CC} \times I_{CC} \quad [W]$$

where:

W_{VCC} is the consumed power of the V_{CC} .

V_{CC} is the power supply voltage.

I_{CC} is the circuit current.

$$W_{DMOS} = W_{ON} + W_{DECAY} \quad [W]$$

$$W_{ON} = (R_{ONH} + R_{ONL}) \times I_{OUT}^2 \times \frac{on_duty}{100} \quad [W]$$

$$W_{DECAY} = (2 \times R_{ONL}) \times I_{OUT}^2 \times \frac{100-on_duty}{100} \quad [W]$$

where:

W_{DMOS} is the consumed power of the output DMOS.

W_{ON} is the consumed power during output ON.

W_{DECAY} is the consumed power during current decay.

R_{ONH} is the upper P-channel DMOS ON-resistance.

R_{ONL} is the lower N-channel DMOS ON-resistance.

I_{OUT} is the motor output current value.

on_duty is PWM on duty[%].

Model Number	Upper P-Channel DMOS ON-Resistance $R_{ONH}[\Omega]$ (Typ)	Lower N-Channel DMOS ON-Resistance $R_{ONL}[\Omega]$ (Typ)
BD60203EFV	0.40	0.25

$$W_{total} = W_{VCC} + W_{DMOS} \quad [W]$$

$$T_j = T_a + \theta_{ja} \times W_{total} \quad [^\circ C]$$

where:

W_{total} is the upper P-channel DMOS ON-resistance.

T_j is the junction temperature.

T_a is the air temperature.

θ_{ja} is the thermal resistance value.

However, the thermal resistance value θ_{ja} [°C/W] differs greatly depending on circuit board conditions. The calculated values above are only theoretical. For actual thermal design, perform sufficient thermal evaluation for the application board used, and create the thermal design with enough margin not to exceed $T_{jmax}=150$ °C. Although unnecessary with normal use, if the IC is to be used under especially strict heat conditions, consider externally attaching a Schottky diode between the motor output pin and GND to abate heat from the IC.

Power Dissipation – continued

Temperature Monitoring

There is a way to directly measure the approximate chip temperature by using the TEST pin. However, temperature monitor using the TEST pin is only for evaluation and experimenting, and must not be used in actual usage conditions. The TEST pin has a protection diode to prevent electrostatic discharge. The temperature can be monitored using this protection diode.

- (1) Measure the pin voltage when a current of $I_{DIODE}=50 \mu A$ flows from the TEST pin to the GND, without supplying VCC to the IC. This measurement is the V_F voltage inside the diode.
- (2) Measure the temperature characteristics of this pin voltage. (V_F has a linear negative temperature factor against the temperature.) With the results of these temperature characteristics, chip temperature can be calibrated from the TEST pin voltage.
- (3) Supply VCC, confirm the TEST pin voltage while running the motor, and the chip temperature can be approximated from the results of (2).

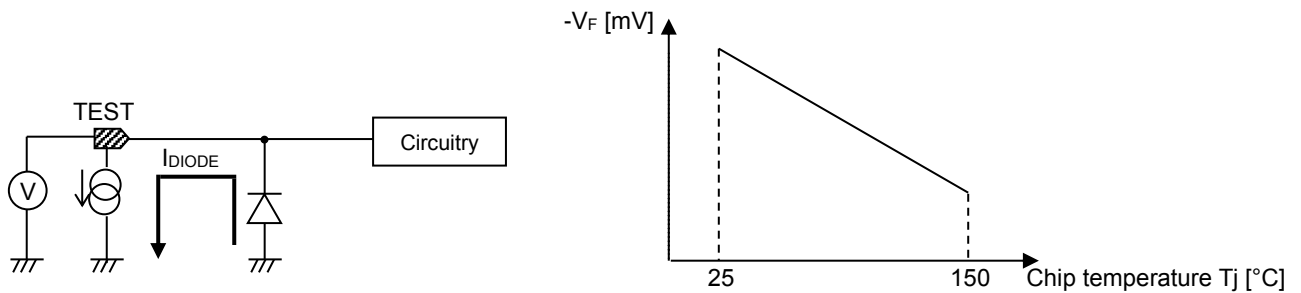

Figure 7. Model Diagram for Measuring Chip Temperature

Application Examples

Constant Voltage Control or External PWM Control

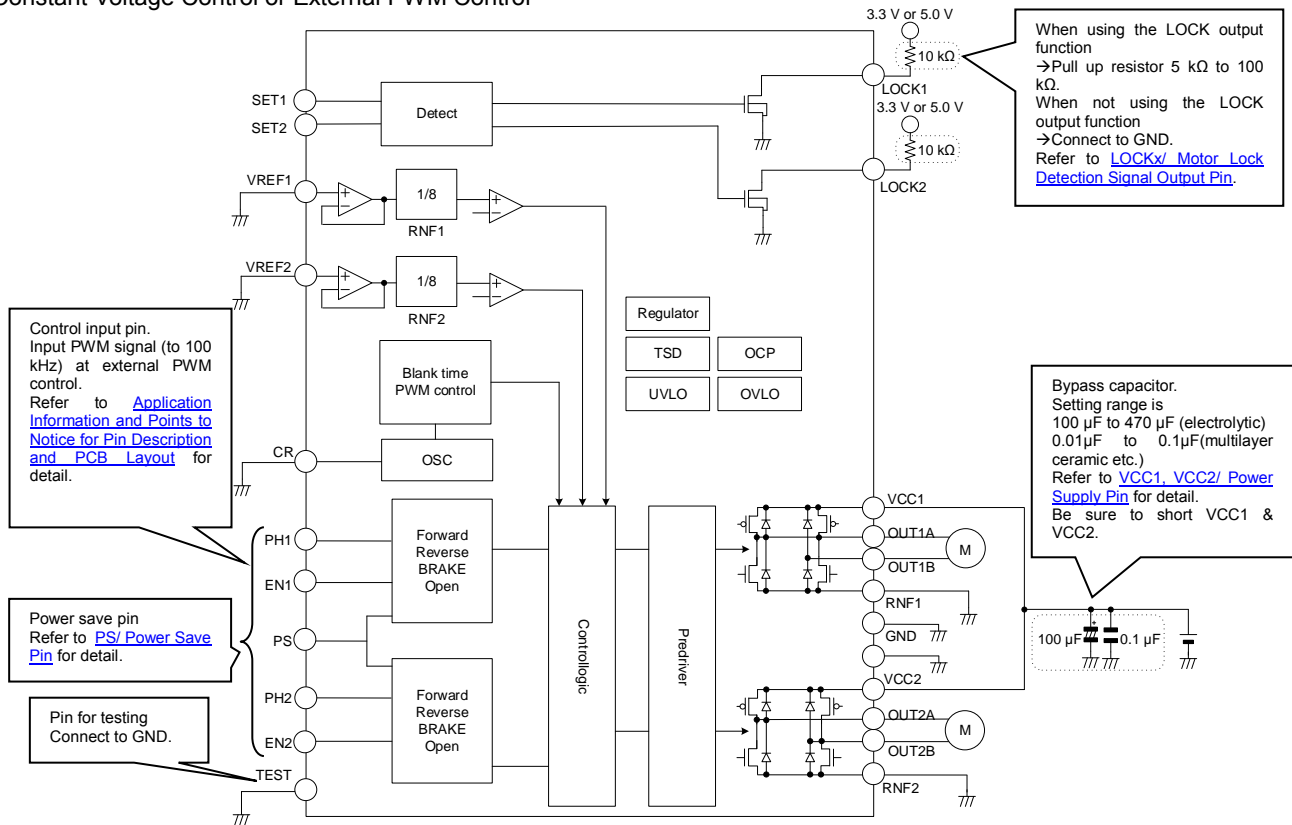

Figure 8. Block Diagram & Application Circuit Diagram

(1) Input/Output table

Input			Output		State
PS	EN1 EN2	PH1 PH2	OUT1A OUT2A	OUT1B OUT2B	
L	x ^(Note 20)	x ^(Note 20)	OPEN	OPEN	POWER SAVE (STANDBY)
H	L	L	OPEN	OPEN	STOP
H	H	H	H	L	FORWARD
H	H	L	L	H	REVERSE
H	L	H	L	L	BRAKE

(Note 20) x=H or L

(2) Example of external PWM control sequence
SLOW DECAY (forward rotation)

Input			Output		State
PS	EN1 EN2	PH1 PH2	OUT1A OUT2A	OUT1B OUT2B	
H	H	H	H	L	ON
H	L	H	L	L	SLOW DECAY
H	H	H	H	L	ON
H	L	H	L	L	SLOW DECAY
H	H	H	H	L	ON

FAST DECAY (forward rotation)

Input			Output		State
PS	EN1 EN2	PH1 PH2	OUT1A OUT2A	OUT1B OUT2B	
H	H	H	H	L	ON
H	H	L	L	H	FAST DECAY
H	H	H	H	L	ON
H	H	L	L	H	FAST DECAY
H	H	H	H	L	ON

Application Examples – continued

PWM Constant Current Control

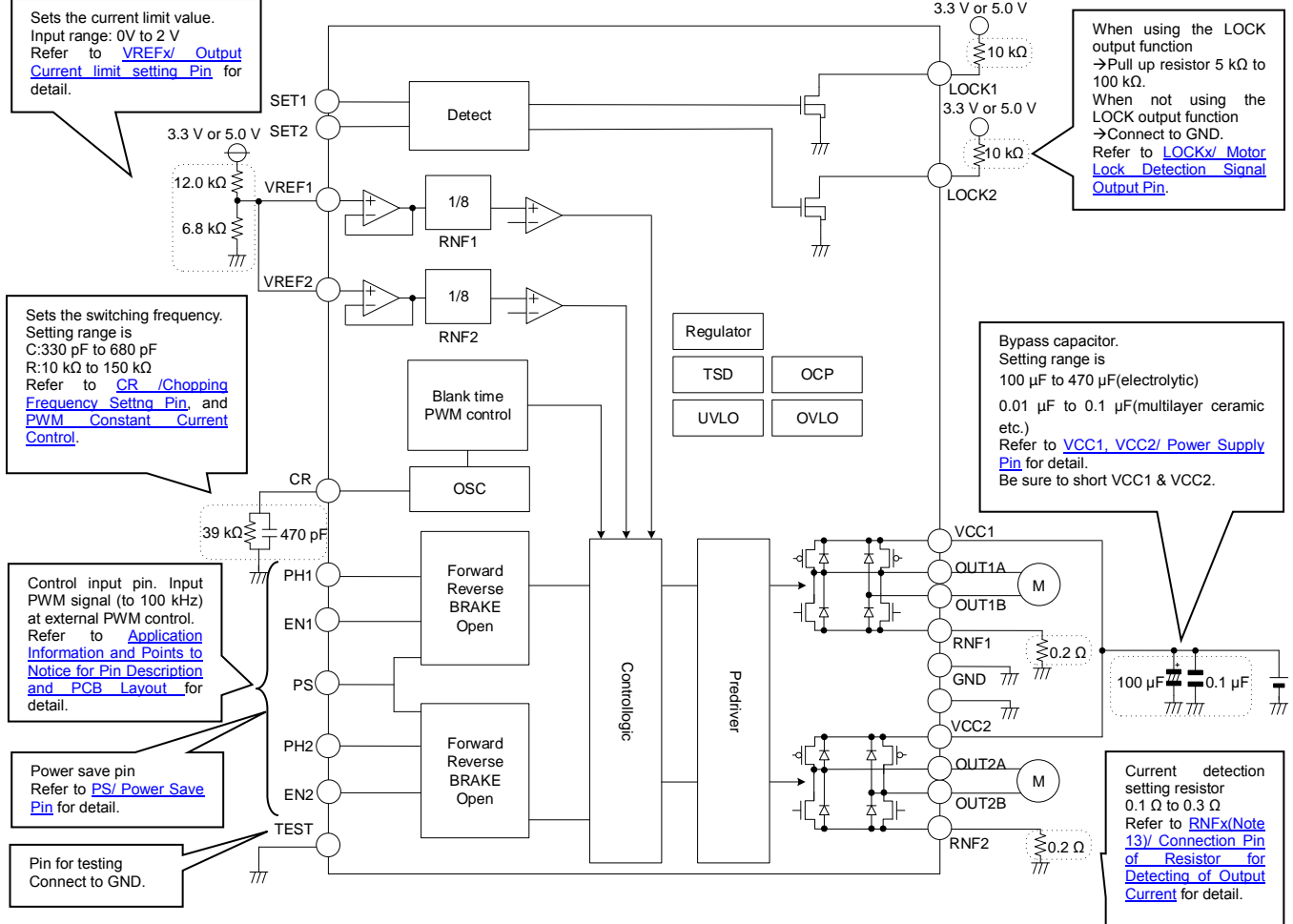

Figure 9. Application Circuit Diagram of Constant Voltage Control or External PWM Control

Input/Output table

Input		Output			State
PS	EN1 EN2	PH1 PH2	OUT1A OUT2A	OUT1B OUT2B	
L	x ^(Note 21)	x ^(Note 21)	OPEN	OPEN	POWER SAVE (STANDBY)
H	L	L	OPEN	OPEN	STOP
H	H	H	H	L	FORWARD
H	H	L	L	H	REVERSE
H	L	H	L	L	BRAKE

(Note 21) x=H or L

I/O Equivalence Circuits

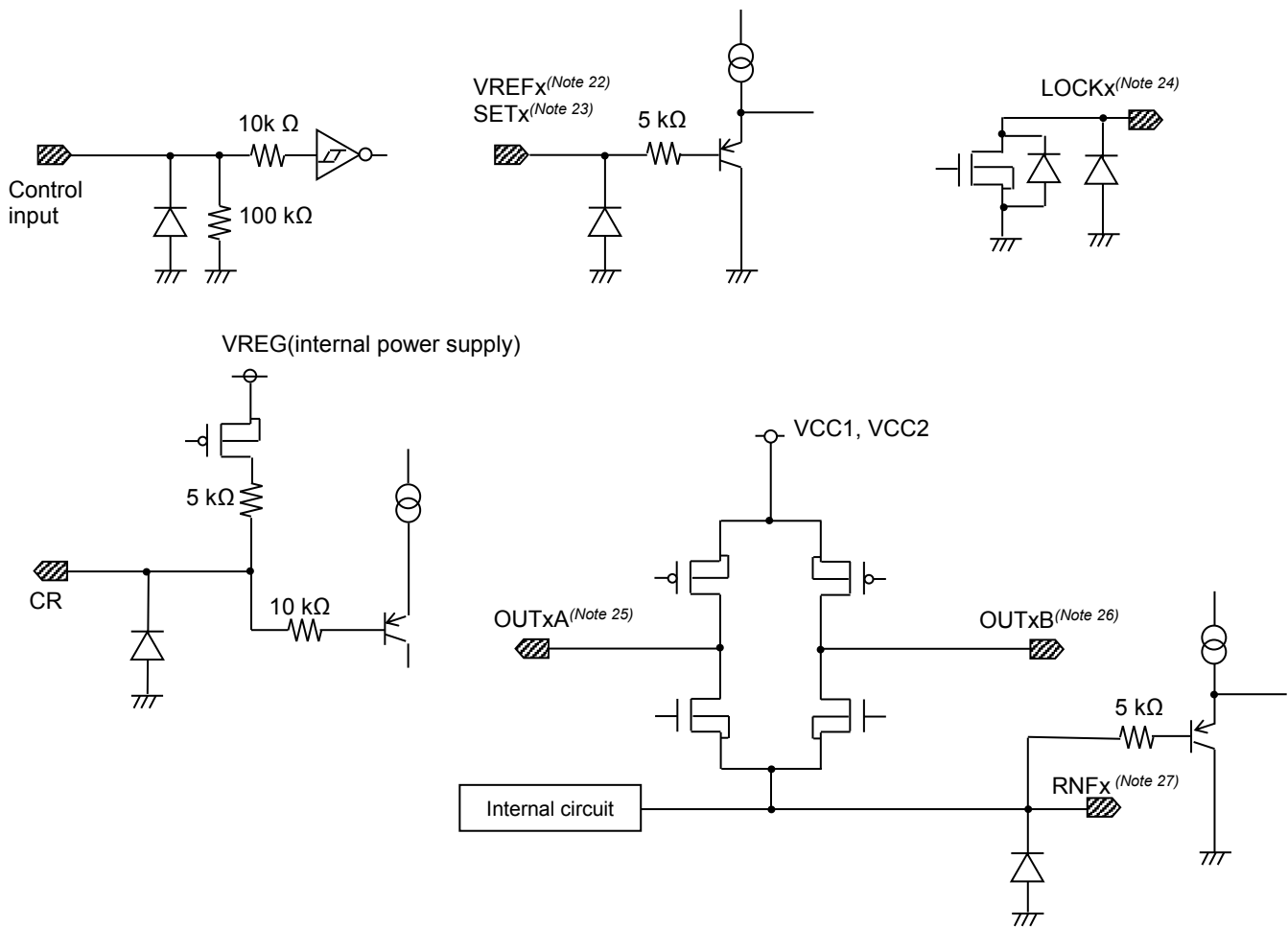

(Note 22) x=1 or 2
 (Note 23) x=1 or 2
 (Note 24) x=1 or 2
 (Note 25) x=1 or 2
 (Note 26) x=1 or 2
 (Note 27) x=1 or 2

Operational Notes

1. Reverse Connection of Power Supply

Connecting the power supply in reverse polarity can damage the IC. Take precautions against reverse polarity when connecting the power supply, such as mounting an external diode between the power supply and the IC's power supply pins.

2. Power Supply Lines

Design the PCB layout pattern to provide low impedance supply lines. Furthermore, connect a capacitor to ground at all power supply pins. Consider the effect of temperature and aging on the capacitance value when using electrolytic capacitors.

3. Ground Voltage

Ensure that no pins are at a voltage below that of the ground pin at any time, even during transient condition.

4. Ground Wiring Pattern

When using both small-signal and large-current ground traces, the two ground traces should be routed separately but connected to a single ground at the reference point of the application board to avoid fluctuations in the small-signal ground caused by large currents. Also ensure that the ground traces of external components do not cause variations on the ground voltage. The ground lines must be as short and thick as possible to reduce line impedance.

5. Recommended Operating Conditions

The function and operation of the IC are guaranteed within the range specified by the recommended operating conditions. The characteristic values are guaranteed only under the conditions of each item specified by the electrical characteristics.

6. Inrush Current

When power is first supplied to the IC, it is possible that the internal logic may be unstable and inrush current may flow instantaneously due to the internal powering sequence and delays, especially if the IC has more than one power supply. Therefore, give special consideration to power coupling capacitance, power wiring, width of ground wiring, and routing of connections.

7. Operation Under Strong Electromagnetic Field

Operating the IC in the presence of a strong electromagnetic field may cause the IC to malfunction.

8. Testing on Application Boards

When testing the IC on an application board, connecting a capacitor directly to a low-impedance output pin may subject the IC to stress. Always discharge capacitors completely after each process or step. The IC's power supply should always be turned off completely before connecting or removing it from the test setup during the inspection process. To prevent damage from static discharge, ground the IC during assembly and use similar precautions during transport and storage.

9. Inter-pin Short and Mounting Errors

Ensure that the direction and position are correct when mounting the IC on the PCB. Incorrect mounting may result in damaging the IC. Avoid nearby pins being shorted to each other especially to ground, power supply and output pin. Inter-pin shorts could be due to many reasons such as metal particles, water droplets (in very humid environment) and unintentional solder bridge deposited in between pins during assembly to name a few.

10. Unused Input Pins

Input pins of an IC are often connected to the gate of a MOS transistor. The gate has extremely high impedance and extremely low capacitance. If left unconnected, the electric field from the outside can easily charge it. The small charge acquired in this way is enough to produce a significant effect on the conduction through the transistor and cause unexpected operation of the IC. So unless otherwise specified, unused input pins should be connected to the power supply or ground line.

Operational Notes – continued

11. Regarding the Input Pin of the IC

This monolithic IC contains P+ isolation and P substrate layers between adjacent elements in order to keep them isolated. P-N junctions are formed at the intersection of the P layers with the N layers of other elements, creating a parasitic diode or transistor. For example (refer to figure below):

When GND > Pin A and GND > Pin B, the P-N junction operates as a parasitic diode.
 When GND > Pin B, the P-N junction operates as a parasitic transistor.

Parasitic diodes inevitably occur in the structure of the IC. The operation of parasitic diodes can result in mutual interference among circuits, operational faults, or physical damage. Therefore, conditions that cause these diodes to operate, such as applying a voltage lower than the GND voltage to an input pin (and thus to the P substrate) should be avoided.

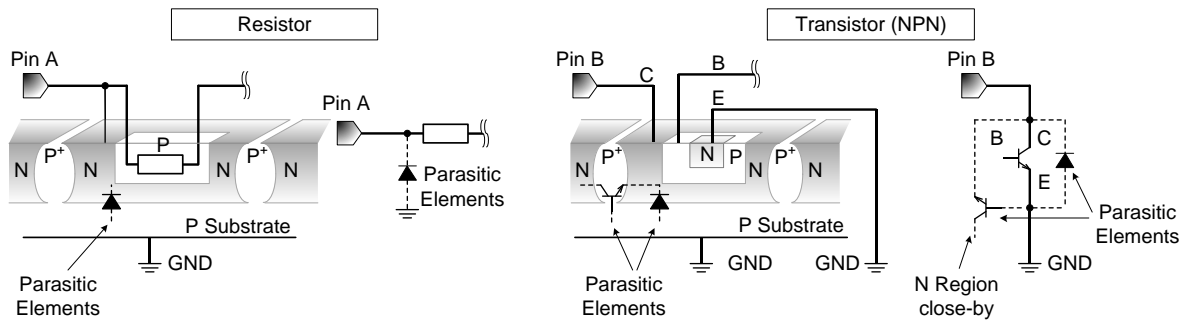

Figure 10. Example of Monolithic IC Structure

12. Thermal Shutdown Circuit(TSD)

This IC has a built-in thermal shutdown circuit that prevents heat damage to the IC. Normal operation should always be within the IC's maximum junction temperature rating. If however the rating is exceeded for a continued period, the junction temperature (Tj) will rise which will activate the TSD circuit that will turn OFF power output pins. When the Tj falls below the TSD threshold, the circuits are automatically restored to normal operation.

Note that the TSD circuit operates in a situation that exceeds the absolute maximum ratings and therefore, under no circumstances, should the TSD circuit be used in a set design or for any purpose other than protecting the IC from heat damage.

13. Over Current Protection Circuit (OCP)

This IC incorporates an integrated overcurrent protection circuit that is activated when the load is shorted. This protection circuit is effective in preventing damage due to sudden and unexpected incidents. However, the IC should not be used in applications characterized by continuous operation or transitioning of the protection circuit.

Ordering Information

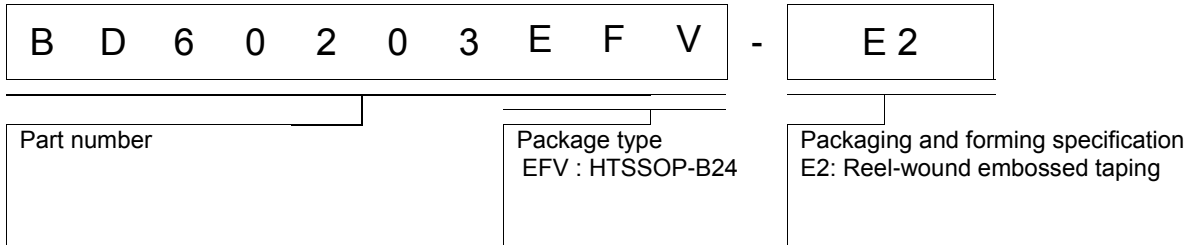

Marking Diagram

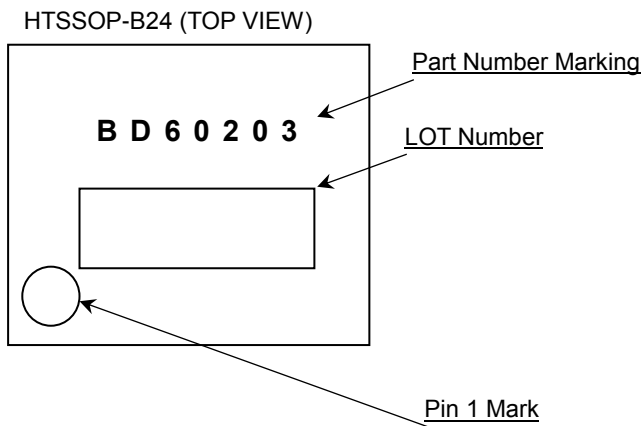

Physical Dimension and Packing Information

Package Name	HTSSOP-B24
--------------	------------

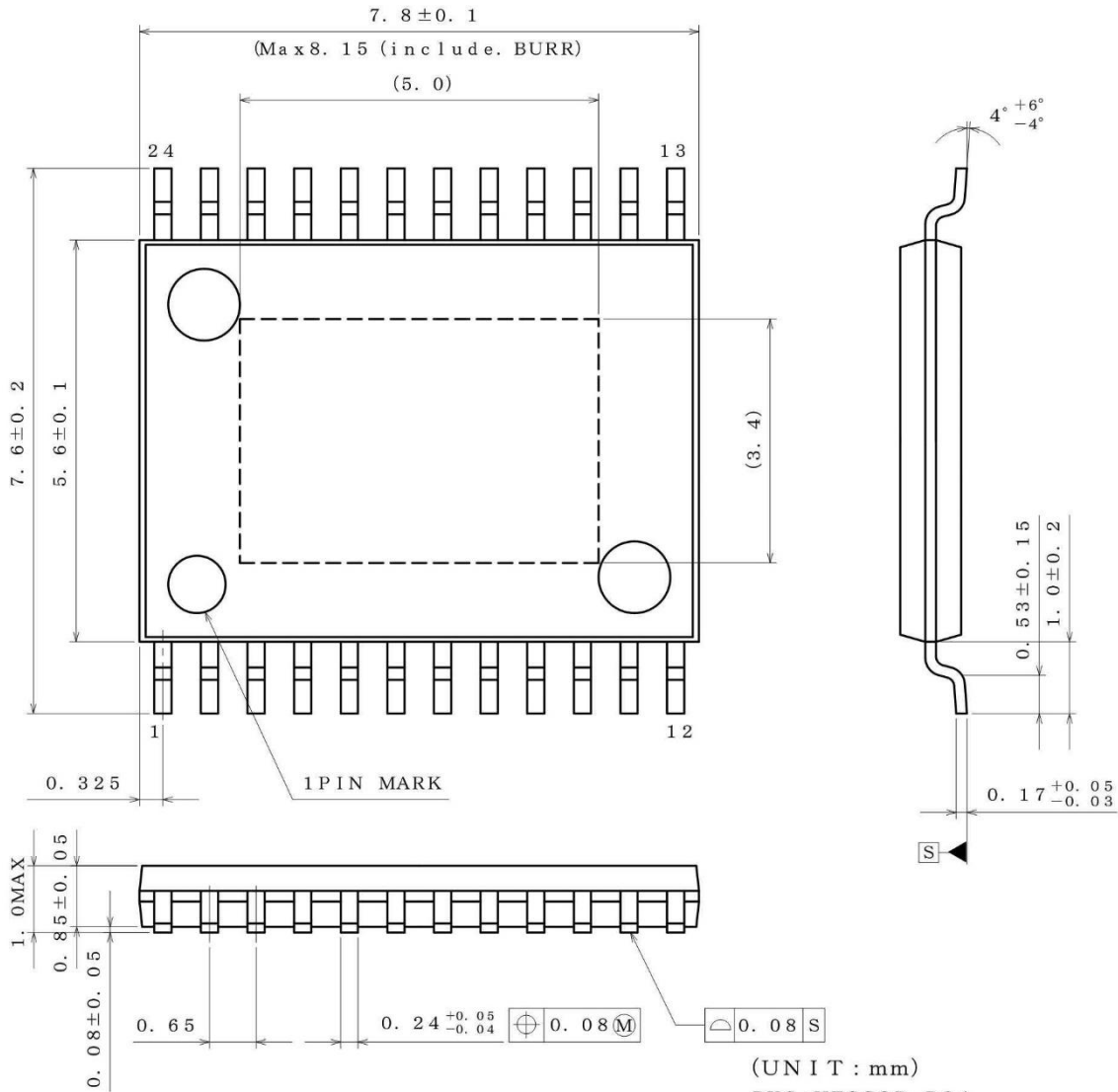

(UNIT : mm)
 PKG : HTSSOP-B24
 Drawing No. EX191-5002-1

< Tape and Reel Information >

Tape	Embossed carrier tape (with dry pack)
Quantity	2000pcs
Direction of feed	E2 The direction is the pin 1 of product is at the upper left when you hold reel on the left hand and you pull out the tape on the right hand

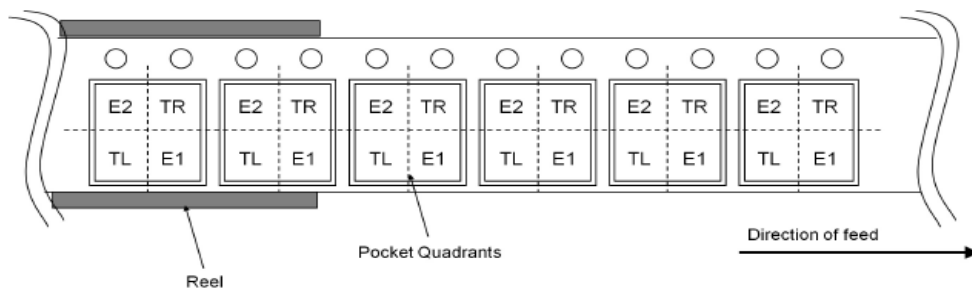

Revision History

Date	Revision	Changes
21.May.2018	001	New Release

Notice

Precaution on using ROHM Products

- Our Products are designed and manufactured for application in ordinary electronic equipment (such as AV equipment, OA equipment, telecommunication equipment, home electronic appliances, amusement equipment, etc.). If you intend to use our Products in devices requiring extremely high reliability (such as medical equipment ^(Note 1), transport equipment, traffic equipment, aircraft/spacecraft, nuclear power controllers, fuel controllers, car equipment including car accessories, safety devices, etc.) and whose malfunction or failure may cause loss of human life, bodily injury or serious damage to property ("Specific Applications"), please consult with the ROHM sales representative in advance. Unless otherwise agreed in writing by ROHM in advance, ROHM shall not be in any way responsible or liable for any damages, expenses or losses incurred by you or third parties arising from the use of any ROHM's Products for Specific Applications.

(Note1) Medical Equipment Classification of the Specific Applications

JAPAN	USA	EU	CHINA
CLASS III	CLASS III	CLASS II b	CLASS III
CLASS IV		CLASS III	

- ROHM designs and manufactures its Products subject to strict quality control system. However, semiconductor products can fail or malfunction at a certain rate. Please be sure to implement, at your own responsibilities, adequate safety measures including but not limited to fail-safe design against the physical injury, damage to any property, which a failure or malfunction of our Products may cause. The following are examples of safety measures:
 - Installation of protection circuits or other protective devices to improve system safety
 - Installation of redundant circuits to reduce the impact of single or multiple circuit failure
- Our Products are designed and manufactured for use under standard conditions and not under any special or extraordinary environments or conditions, as exemplified below. Accordingly, ROHM shall not be in any way responsible or liable for any damages, expenses or losses arising from the use of any ROHM's Products under any special or extraordinary environments or conditions. If you intend to use our Products under any special or extraordinary environments or conditions (as exemplified below), your independent verification and confirmation of product performance, reliability, etc. prior to use, must be necessary:
 - Use of our Products in any types of liquid, including water, oils, chemicals, and organic solvents
 - Use of our Products outdoors or in places where the Products are exposed to direct sunlight or dust
 - Use of our Products in places where the Products are exposed to sea wind or corrosive gases, including Cl₂, H₂S, NH₃, SO₂, and NO₂
 - Use of our Products in places where the Products are exposed to static electricity or electromagnetic waves
 - Use of our Products in proximity to heat-producing components, plastic cords, or other flammable items
 - Sealing or coating our Products with resin or other coating materials
 - Use of our Products without cleaning residue of flux (even if you use no-clean type fluxes, cleaning residue of flux is recommended); or Washing our Products by using water or water-soluble cleaning agents for cleaning residue after soldering
 - Use of the Products in places subject to dew condensation
- The Products are not subject to radiation-proof design.
- Please verify and confirm characteristics of the final or mounted products in using the Products.
- In particular, if a transient load (a large amount of load applied in a short period of time, such as pulse. is applied, confirmation of performance characteristics after on-board mounting is strongly recommended. Avoid applying power exceeding normal rated power; exceeding the power rating under steady-state loading condition may negatively affect product performance and reliability.
- De-rate Power Dissipation depending on ambient temperature. When used in sealed area, confirm that it is the use in the range that does not exceed the maximum junction temperature.
- Confirm that operation temperature is within the specified range described in the product specification.
- ROHM shall not be in any way responsible or liable for failure induced under deviant condition from what is defined in this document.

Precaution for Mounting / Circuit board design

- When a highly active halogenous (chlorine, bromine, etc.) flux is used, the residue of flux may negatively affect product performance and reliability.
- In principle, the reflow soldering method must be used on a surface-mount products, the flow soldering method must be used on a through hole mount products. If the flow soldering method is preferred on a surface-mount products, please consult with the ROHM representative in advance.

For details, please refer to ROHM Mounting specification

Precautions Regarding Application Examples and External Circuits

1. If change is made to the constant of an external circuit, please allow a sufficient margin considering variations of the characteristics of the Products and external components, including transient characteristics, as well as static characteristics.
2. You agree that application notes, reference designs, and associated data and information contained in this document are presented only as guidance for Products use. Therefore, in case you use such information, you are solely responsible for it and you must exercise your own independent verification and judgment in the use of such information contained in this document. ROHM shall not be in any way responsible or liable for any damages, expenses or losses incurred by you or third parties arising from the use of such information.

Precaution for Electrostatic

This Product is electrostatic sensitive product, which may be damaged due to electrostatic discharge. Please take proper caution in your manufacturing process and storage so that voltage exceeding the Products maximum rating will not be applied to Products. Please take special care under dry condition (e.g. Grounding of human body / equipment / solder iron, isolation from charged objects, setting of Ionizer, friction prevention and temperature / humidity control).

Precaution for Storage / Transportation

1. Product performance and soldered connections may deteriorate if the Products are stored in the places where:
 - [a] the Products are exposed to sea winds or corrosive gases, including Cl₂, H₂S, NH₃, SO₂, and NO₂
 - [b] the temperature or humidity exceeds those recommended by ROHM
 - [c] the Products are exposed to direct sunshine or condensation
 - [d] the Products are exposed to high Electrostatic
2. Even under ROHM recommended storage condition, solderability of products out of recommended storage time period may be degraded. It is strongly recommended to confirm solderability before using Products of which storage time is exceeding the recommended storage time period.
3. Store / transport cartons in the correct direction, which is indicated on a carton with a symbol. Otherwise bent leads may occur due to excessive stress applied when dropping of a carton.
4. Use Products within the specified time after opening a humidity barrier bag. Baking is required before using Products of which storage time is exceeding the recommended storage time period.

Precaution for Product Label

A two-dimensional barcode printed on ROHM Products label is for ROHM's internal use only.

Precaution for Disposition

When disposing Products please dispose them properly using an authorized industry waste company.

Precaution for Foreign Exchange and Foreign Trade act

Since concerned goods might be fallen under listed items of export control prescribed by Foreign exchange and Foreign trade act, please consult with ROHM in case of export.

Precaution Regarding Intellectual Property Rights

1. All information and data including but not limited to application example contained in this document is for reference only. ROHM does not warrant that foregoing information or data will not infringe any intellectual property rights or any other rights of any third party regarding such information or data.
2. ROHM shall not have any obligations where the claims, actions or demands arising from the combination of the Products with other articles such as components, circuits, systems or external equipment (including software).
3. No license, expressly or implied, is granted hereby under any intellectual property rights or other rights of ROHM or any third parties with respect to the Products or the information contained in this document. Provided, however, that ROHM will not assert its intellectual property rights or other rights against you or your customers to the extent necessary to manufacture or sell products containing the Products, subject to the terms and conditions herein.

Other Precaution

1. This document may not be reprinted or reproduced, in whole or in part, without prior written consent of ROHM.
2. The Products may not be disassembled, converted, modified, reproduced or otherwise changed without prior written consent of ROHM.
3. In no event shall you use in any way whatsoever the Products and the related technical information contained in the Products or this document for any military purposes, including but not limited to, the development of mass-destruction weapons.
4. The proper names of companies or products described in this document are trademarks or registered trademarks of ROHM, its affiliated companies or third parties.

General Precaution

1. Before you use our Products, you are requested to carefully read this document and fully understand its contents. ROHM shall not be in any way responsible or liable for failure, malfunction or accident arising from the use of any ROHM's Products against warning, caution or note contained in this document.
2. All information contained in this document is current as of the issuing date and subject to change without any prior notice. Before purchasing or using ROHM's Products, please confirm the latest information with a ROHM sales representative.
3. The information contained in this document is provided on an "as is" basis and ROHM does not warrant that all information contained in this document is accurate and/or error-free. ROHM shall not be in any way responsible or liable for any damages, expenses or losses incurred by you or third parties resulting from inaccuracy or errors of or concerning such information.