



BYD Microelectronics Co., Ltd.

BF1501 Series

Off Line AC/DC Switcher IC

General Description

The THCOX switcher ICs cost effectively replace all power supplies up to 5W output power based on unregulated isolated linear transformer (50/60HZ). Unlike conventional PWM (pulse width modulation) controllers, it regulates the output voltage in a new method of off-time modulation control. The controller consists of a VCO (voltage control oscillator), Sense and logic circuit, VDD pin, under-voltage lockout circuit, over-voltage protection, current limited circuit, leading edge blanking, over load protection and fault condition auto-restart. They are ideal low power AC/DC adapter/charger for cell phones.

Applications

- AC/DC adapter/charger for cell/cordless phones, digital cameras, MP3/portable audio devices etc
- LED Lighting
- Replacements for linear transformers and RCC SMPTPS

Features

- **Low start-up current**
 - Typ.15 μ A
 - Max.25 μ A
- **Low operating current**
 - Typ.2 mA
 - Max.5 mA
- **UVLO(under voltage lockout)**
 - Typ.12V start-up
 - Typ.6V shut-down
- **LEB(leading edge blanking)**
 - Typ.300ns
- **OVP(over voltage protection)**
 - Typ.28 V
- **Operation Frequency**
 - Typ.50KHZ
- **Output Driver Ability**
 - Typ.15 mA
- **OLP(over load protection)**
- **Universal AC input range**
- **Constant voltage and constant current**
- **Small SOT-23-6 Package**

Notes

Typical Application Circuits

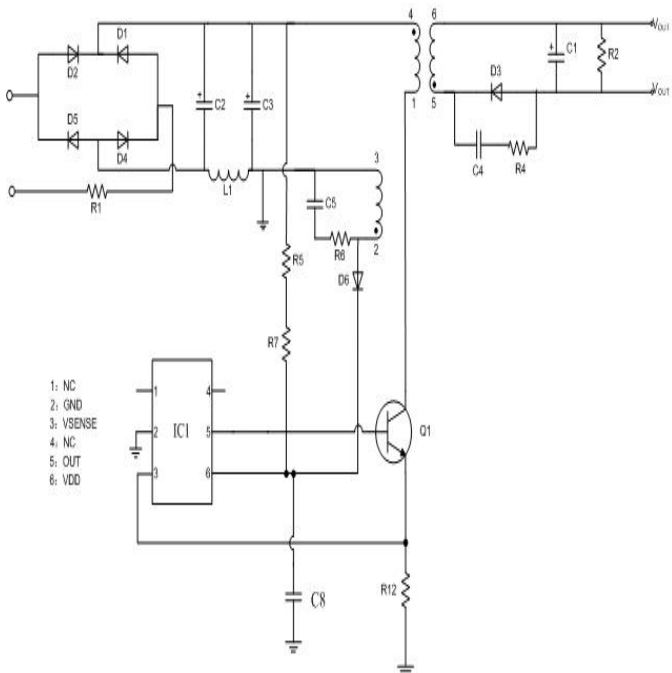

Block Diagram

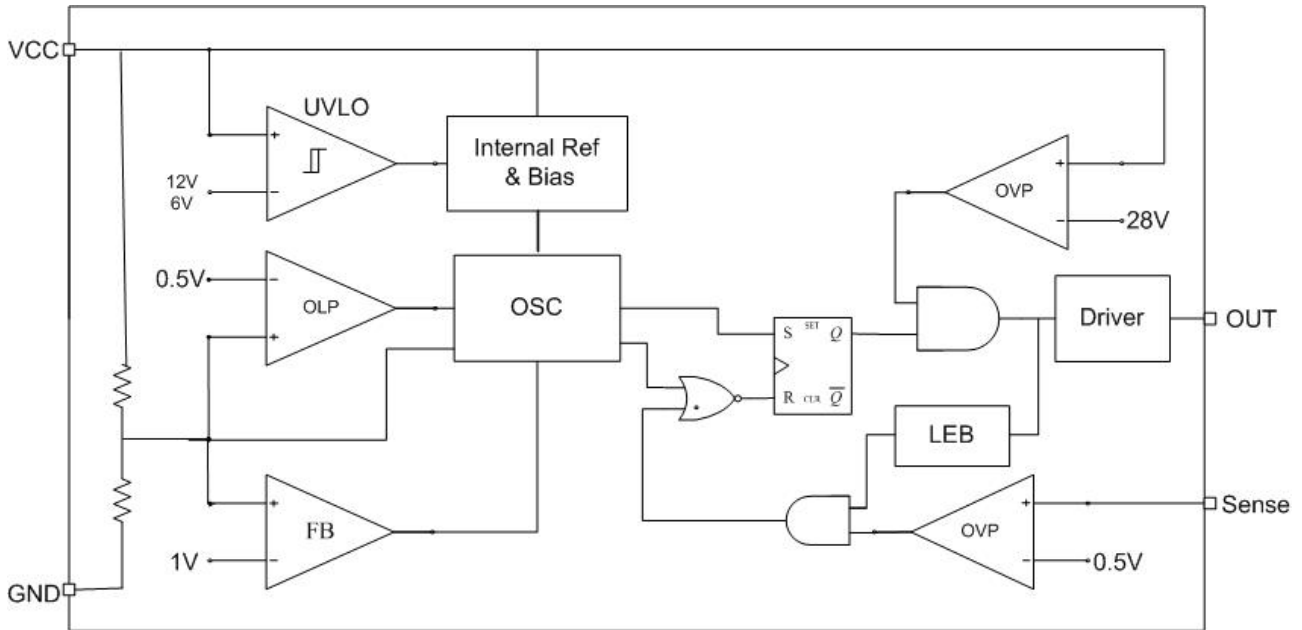

Package Type

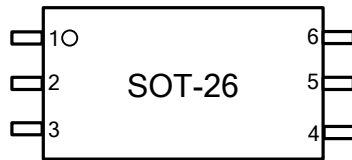

Pin Description

Pin number	Pin name	Description
1	NC	Not connected
2	GND	Ground
3	Sense	Current sensor, it senses the voltage via a sensed resistor
4	NC	Not connected
5	V _{out}	Gate drive output for the external power BJT switch
6	VDD	Power Supply



Function Description

1. Under Voltage Lockout

The turn-on and turn-off thresholds of the THC01 are fixed internally at 12V/6V. During start-up, the hold-up capacitor must be charged to 12V through the start-up resistor, so that the THC01 can be enabled. The hold-up capacitor will continue to supply VDD until power can be delivered from the auxiliary winding of the main transformer. When VDD drops below 6V, IC will be shut-down, and have to start-up again. This UVLO hysteretic window ensures that THC01 can start-up very well.

2. Leading Edge Blanking

When the power BJT is switched on, a voltage spike will inevitably occur at the sense pin. To avoid premature termination of the switching pulse, a 350 ns leading-edge blanking time is built in THC01. Conventional RC filtering can be omitted. During this blanking period, the current-limit comparator is disabled and it cannot switch off the gate driver.

3. Voltage Control Oscillator

The sense circuit of THC0X series will sense the voltage of VDD pin (also the power pin of THC01) and then control the frequency of the oscillator. The max frequency of THC0X is set to the rated output power point and for THC01 is 50 KHZ. Two signals are generated from the oscillator: the maximum duty cycle signal (DC max) and the clock signal that indicates the beginning of each switching cycle.

4. Sense Circuit

A resistor voltage divided circuit is connected between the VDD and GND pin in order to sample the feedback voltage at VDD pin. When the voltage of VDD pin exceeds 20V, IC will come into constant voltage control mode, shut down the output pin and start a bypass current. This bypass current is linearly controlled by the feedback voltage. When the voltage of VDD pin falls below 20V, the off-time linearly increases in order to have a constant current output.

5. Gate Output

Unlike other chips, THC01 used a constant current circuit to drive the output BJT. The output current is fixed at 15mA, select the appropriate hFE of BJT could have a different output power.

6. Fault Condition Auto-restart

In the event of a fault condition such as output over-load or short circuit, THC0X enter into auto-restart operation. It is using the turn-on and turn-off threshold again. THC0X is working in start mode to protect the system from damage caused by the fault condition.

7. Current Limit

The current limit circuit detects the current through the power BJT. This current flows through the sense-resistor and makes the voltage on Vsense pin ramp up. When this voltage exceeds the internal threshold (Vlimit), the power BJT is turned off immediately.

**Electrical Characteristic**

Item	Conditions	Min.	Typ.	Max.	Unit
Supply voltage					
Start-up Current	VCC=VCCON-0.1		15	25	μA
Operation voltage	25°C		21		V
Turn-on Threshold Voltage	VCCON	11	12	13	V
Turn-off Threshold Voltage	VCCOFF	5.5	6	6.5	V
Over-voltage Threshold	VOVP		28	30	V
Oscillator					
Output Frequency	25°C	40	50	60	KHz
Duty Cycle	Vsense=0			70%	
Green Mode Frequency	25°C	16	20	24	KHz
Current Sensing					
Leading Edge Blanking	25°C	250	300	350	ns
Current Sense Detection Voltage	VCC=15V	0.45	0.5	0.55	V
Else					
Output Delay Time	25°C		150		ns
Output Driver Current	25°C	12	15	18	mA
Auto-Restart ON Time	25°C		50		ms
Auto-Restart Duty Cycle	25°C		13%		

Absolute Maximum Ratings

Item	Symbol	Value	Unit
VDD input voltage	V _{DD}	40	V
SENSE pin input voltage	V _{SENSE}	7	V
Power Dissipation	P _D	2084	mW
Operating Junction Temperature	T _J	-40 to +125	°C
Storage Temperature Range	T _{STJ}	-55 to +150	°C
Lead temperature	T _L	260	°C
ESD Capability, Human Body Model		2000	V
ESD Capability, Machine Model		50	V

Attention: Stresses beyond those listed under "absolute maximum ratings" may cause permanent damage to the device. Exposure to absolute-maximum-rated conditions for extended periods may affect device reliability.

Test Circuits

(1) Normal operation current consumption

Test circuit 1

Close the S1, connect VSENSE with GND to ground and make the OUT pin floating.

Set $V1=5\pm0.03V$ with 1ms delay time.

Keep v1 powered, increase V1 to $11\pm0.03V$, the current A1 flowing into VDD is the current consumption.

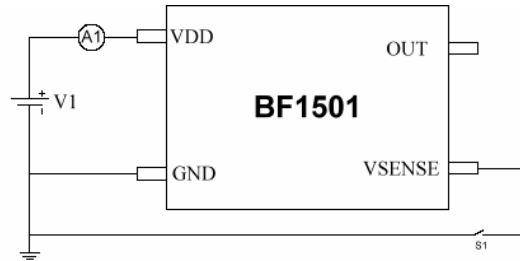

Circuit1: For testing current consumption、CC/CV mode transforming voltage、Hysteresis start-up

(2) Hysteresis start-up

Test circuit 1

When V1 increases over $Vx1$ (the first threshold voltage) from 0V, the IC starts to work normally, and only when V1 decreases under $Vx2$ (the second threshold voltage), the IC stops working and moves into standby mode.

Set $V1=5\pm0.03V$ with 1ms delay time.

Close the S1, connect VSENSE with GND to ground and make the OUT pin floating.

$Vx1$ is the voltage V1 when the output (the OUT pin) frequency changes from $(0\pm1KHZ)$ to $(25\pm10KHZ)$.

$Vx2$ is the voltage V1 when the output (the OUT pin) frequency changes from $(25\pm10KHZ)$ to $(0\pm1KHZ)$.

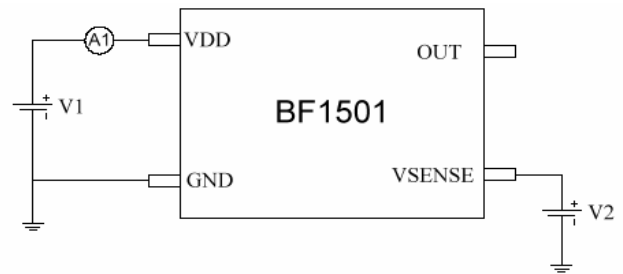

Circuit2: For testing Over current protection detection voltage

(3) CC/CV mode transforming voltage

Test circuit 1

When the voltage increases to a certain value, IC will change from CC mode to CV mode.

Set $V1=5\pm0.03V$ with 1ms delay time.

Close the S1, connect VSENSE with GND to ground and make the OUT pin floating.

The CC/CV mode transforming voltage is the voltage V1 when the output (the OUT pin) frequency changes from $(50\pm10KHZ)$ to $(0\pm1KHZ)$.

(4) Over current protection detection voltage

Test circuit 2

Set $V1=15\pm0.03V$, $V2=0\pm0.03V$, make the OUT pin floating.

The over current protection detection voltage is the voltage V2 when the output (the OUT pin) frequency changes from $(35\pm10KHZ)$ to $(0\pm1KHZ)$.



Typical Characteristic Charts

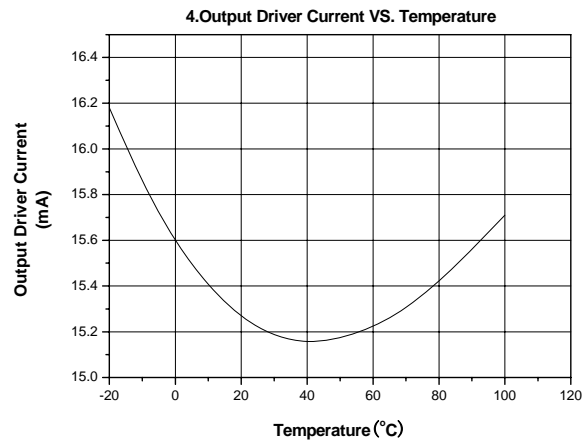
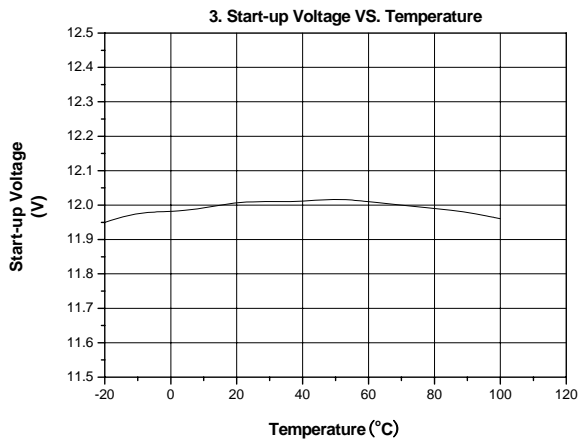
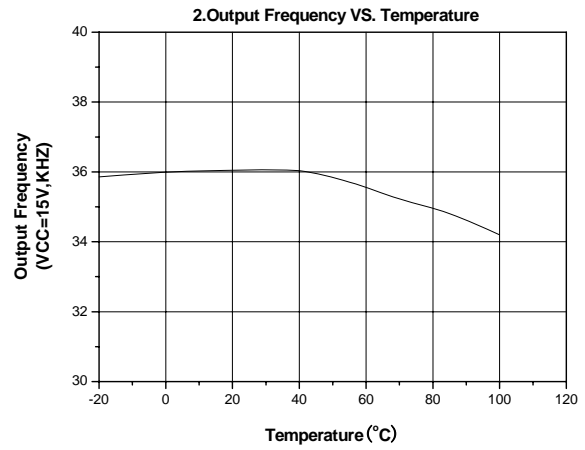
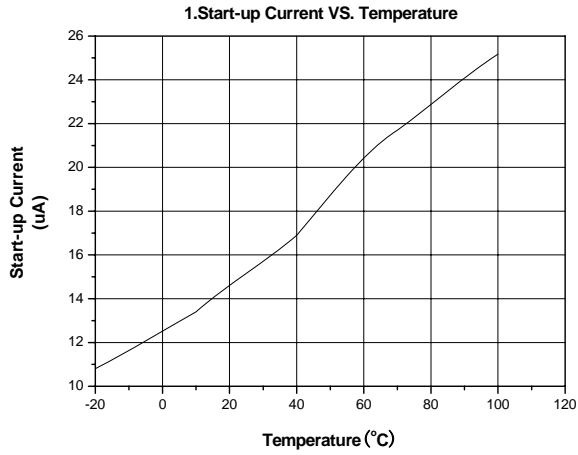

Package outline

SOT-23-6

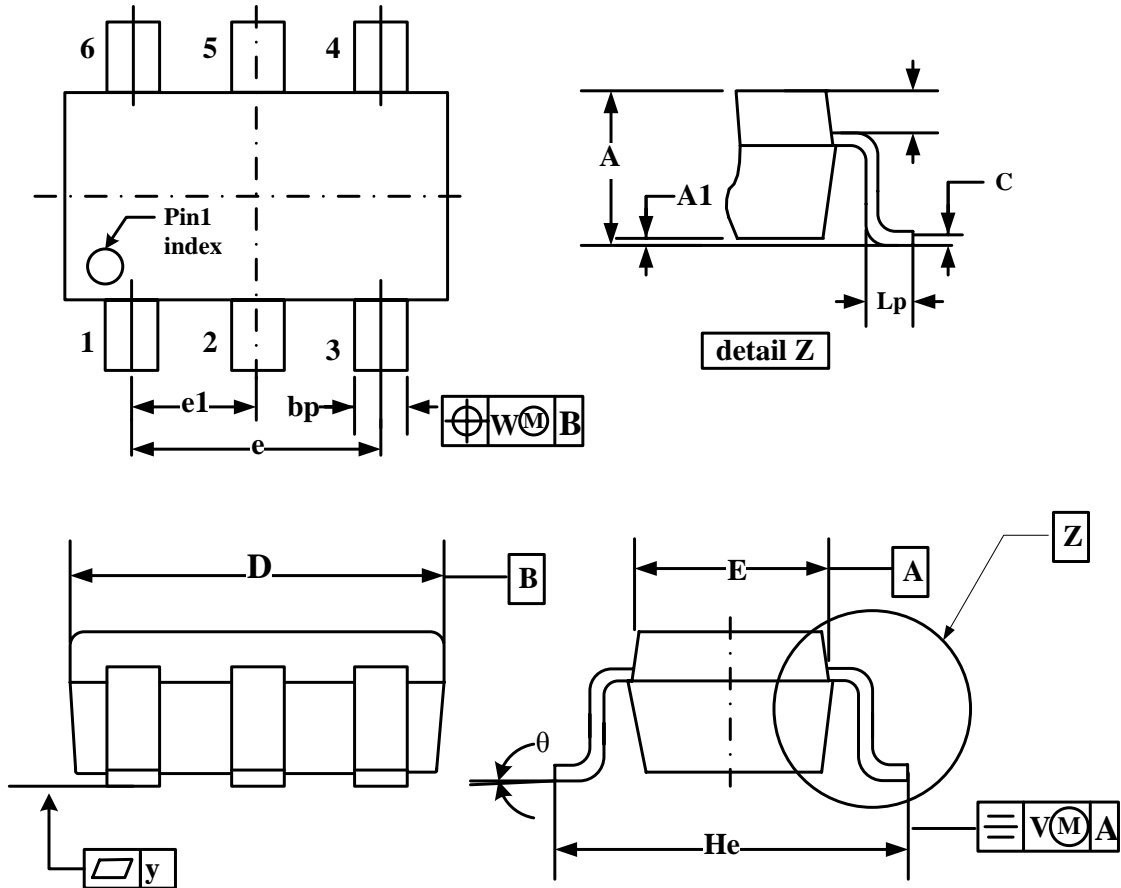

Dimensions (mm)

A	A1	bp	c	D	E	e	e1	He	Lp	Q	v	w	y	θ
1.3	0.15	0.50	0.20	3.1	1.7	1.9	0.95	3.0	0.6	0.33	0.2	0.2	0.1	0°
1.0	0.03	0.35	0.10	2.7	1.3			2.5	0.2	0.23				10°

BYD Microelectronics Co. Ltd. reserves the right to modify the specifications without prior notification.