

# GDT Product Specification

## BF\*\*\*M SMD Gas Discharge Tube (5×5×4.2mm)

RoHS

### 1、FEATURES

- Surface Mounting Design UL Certificated E232249
- Size Design EIA 2018 5×5×4.2mm
- High Current Handling Capability 5,000A @ 8/20μs
- Low Capacitance and Insertion Loss
- Fast Response and Long Service Life
- Reliable to Protect Electrostatic Surge
- Moisture sensitivity level: Level 1



### 2、AVAILABLE PART NUMBER AND ELECTRICAL PARAMETER @ T=25°C RH = 45%-75%

Part Number	DC Breakdown Voltage①	Tolerance	Impulse Spark-over Voltage	Impulse Discharge Current②	Insulation Resistance		C③ (1MHz)
	100V/s④		of Vs	1kV/μs④	8/20μs	GΩ	DC
BF071M	70V	±20%	≤ 650V	5,000A	≥1	25V	≤1pF
BF091M	90V	±20%	≤650V	5,000A	≥1	50V	≤1pF
BF151M	150V	±20%	≤ 650V	5,000A	≥1	50V	≤1pF
BF201M	200V	±20%	≤ 650V	5,000A	≥1	100V	≤1pF
BF231M	230V	±20%	≤ 700V	5,000A	≥1	100V	≤1pF
BF301M	300V	±20%	≤ 700V	5,000A	≥1	100V	≤1pF
BF351M	350V	±20%	≤900V	5,000A	≥1	100V	≤1pF
BF401M	400V	±20%	≤ 950V	5,000A	≥1	100V	≤1pF
BF471M	470V	±20%	≤ 1000V	5,000A	≥1	100V	≤1pF
BF601M	600V	±20%	≤ 1200V	5,000A	≥1	100V	≤1pF
BF801M	800V	±20%	≤ 1600V	3,000A	≥1	100V	≤1.5pF
BF102M	1000V	±20%	≤ 1800V	3,000A	≥1	100V	≤1.5pF
BF122M	1200V	±20%	≤ 2000V	3,000A	≥1	100V	≤1.5pF

- ①、 The parameters of all are tested by ITU-T K12
- ②、 Total Impulse Discharge Current 5,000A @ 8/20μs by IEC 61000-4-5, 10 shots
- ③、 The capacitance are tested by 1MHz @ DC= 0.3V
- ④、 The V-T waveform of DCBV and IPBV mus lie between the shades.

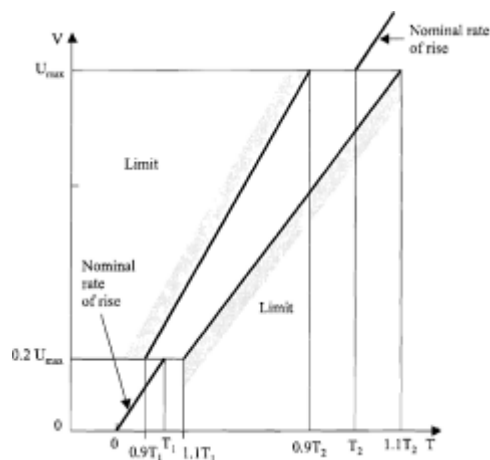

### 3、PART NUMBERING SYSTEM

**BF**      **XXX**      **M**  
 (1)      (2)      (3)

- (1) LangTuo SMD Gas Discharge Tube in 5×5×4.2 (L×W×H) (mm), Total Impulse Discharge Current 5,000A @ 8/20μs
- (2) DC Breakdown Voltage, e.g., 151=15×10<sup>1</sup>=150V
- (3) Tolerance is DC Breakdown Voltage, M=+-20%, N=+-30%

### 4、DIMENSIONS

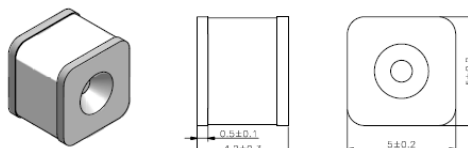

Unit:mm

# GDT Product Specification

**BF\*\*\*M SMD Gas Discharge Tube (5×5×4.2mm)**



## 5、RECOMMENDED SOLDERING PAD AND REFLOW PROFILE

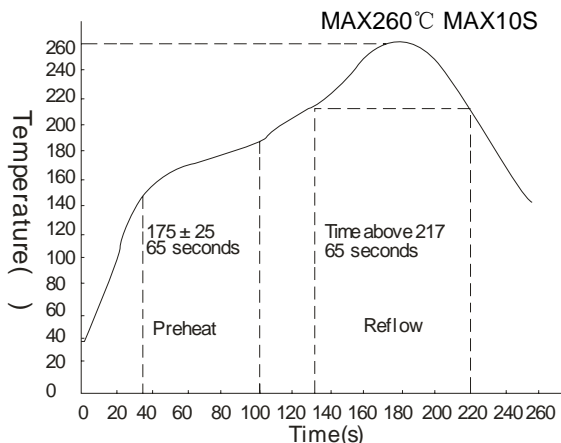
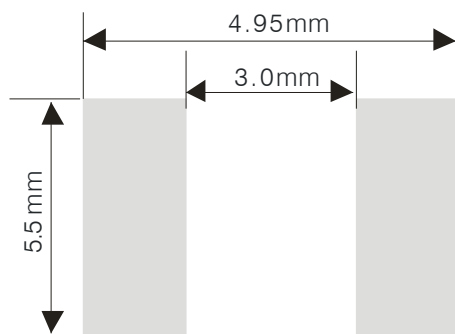

## 6、OPERATION AND STORAGE TEMPERATURE: -40°C ~ +85°C

## 7、PACKAGE REEL INFORMATION

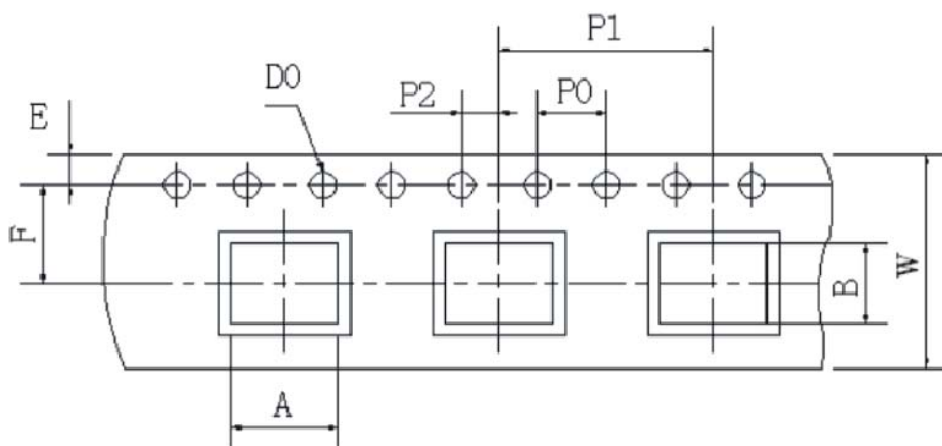

Item	DIM(mm)
A	5.3 ± 0.10
B	4.5 ± 0.20
D0	1.50 ± 0.10
E	1.75 ± 0.10
F	5.5 ± 0.1
P0	4.0 ± 0.1
P1	8.0 ± 0.10
P2	2.0 ± 0.1
W	12.0 ± 0.30

OUTLINE	UNIT WEIGHT (g)	REEL (PCS)	PER CARTON (PCS)	REEL DIAMETERS (mm)	CARTON SIZE(mm)		
					L	W	H
TAPING	~0.5	1,000	16,000	330	360	360	360

**Remark:**

- 1、 Company name change from *Bencent Electronics Limited* to *Shenzhen Lanq Electronics Co., Ltd*
- 2、 Add items of Operation and Storage Temperature
- 3、 Add items of UNIT WEIGHT

**Special Notes**

Date Issued:2010/07