VGA CMOS Image Sensor

BF3006
Datasheet

Preliminary

1. General Description

The BF3006 is a highly integrated VGA camera chip which includes CMOS image sensor (CIS). It is fabricated with the world's most advanced CMOS image sensor process to realize ultra-low dark noise, high sensitivity, high dynamic range and very low power imaging system. The sensor consists of a 648x488 pixel array which has an optical format of 1/4 inch. It has integrated noise canceling CDS (Correlated Double Sampling) circuits, analog global gain and separated R/G/B gain controller, auto black level compensation and on-chip 10-bit ADC. It only provides Bayer RGB output format.

The product is capable of operating at up to 60 frames per second at 27MHz master clock in VGA mode, with complete user control over image quality and data formatting. All required functions, including exposure control, white balance control and so on, should be programmed through the two-wire serial bus.

2. Features

- Standard optical format of 1/4 inch.
- 60 frames/sec VGA mode @ 27MHz xclk clock.
- Ultra-low dark noise at high temperature.
- Ultra-Low power consumption of typical 100mW@60fps(VGA output),60uA@ power down.
- Output format: Raw Bayer (648*488).
- Power supply: 3.3V for VLDO, 1.7V~3.5V for I/O,3.15V~3.45V for VDD3A.
- Horizontal /Vertical mirror.
- 50/60Hz flicker cancellation.
- Auto black level control.
- Package: CSP

3. Applications

- Security systems
- Automotive
- Cellular Phone Cameras
- Notebook and desktop PC cameras
- PDAs
- Toys
- MP4
- Digital still cameras and camcorders
- Video telephony and conferencing equipments
- Industrial and environmental systems

4. Technical Specifications

- Resolution: 648X488
- Pixel size: 6.0umx6.0um
- Sensitivity: 12V/Lux-sec
- Dark current: TBD at 40°C
- Power supply: 3.3V
- Power consumption: 100mW @60fps (VGA output)
- Standby current: TBD
- S/N Ratio: 46 dB
- Dynamic range: 67 dB
- Operating temperature: -30~70°C
- Optimal lens chief ray angle: 10°
- Package: CSP

5. Functional Overview

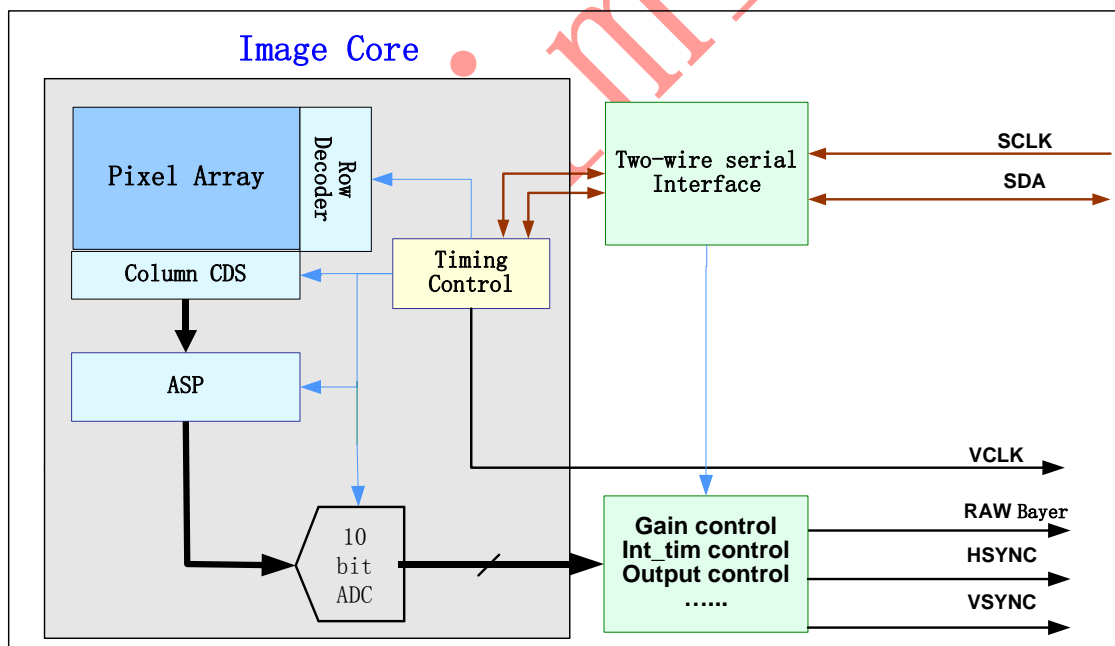

Figure 1. Block Diagram

BF3006 has an active image array of 648x488 pixels. The active pixels are read out progressively through column/row driver circuits. In order to reduce fixed pattern noise, CDS circuits are adopted. The ASP block is mainly used to control global gain and color gains to get accurate exposure and white balance under different light condition and color temperature. The analog signal is transferred to digital signal by A/D converter. The final output digital signals are processed in the control Block.



RESTRICTIONS ON PRODUCT USE

- The information contained herein is subject to change without notice.
- BYD Microelectronics Co., Ltd. (short for BME) exerts the greatest possible effort to ensure high quality and reliability. Nevertheless, semiconductor devices in general can malfunction or fail due to their inherent electrical sensitivity and vulnerability to physical stress. It is the responsibility of the buyer, when utilizing BME products, to comply with the standards of safety in making a safe design for the entire system, including redundancy, fire-prevention measures, and malfunction prevention, to prevent any accidents, fires, or community damage that may ensue. In developing your designs, please ensure that BME products are used within specified operating ranges as set forth in the most recent BME products specifications.
- The BME products listed in this document are intended for usage in general electronics applications (computer, personal equipment, office equipment, measuring equipment, industrial robotics, domestic appliances, etc.). These BME products are neither intended nor warranted for usage in equipment that requires extraordinarily high quality and/or reliability or a malfunction or failure of which may cause loss of human life or bodily injury ("Unintended Usage"). Unintended Usage include atomic energy control instruments, airplane or spaceship instruments, transportation instruments, traffic signal instruments, combustion control instruments, medical instruments, all types of safety devices, etc.. Unintended Usage of BME products listed in this document shall be made at the customer's own risk.

Pre-Release